

IMPORTANT

WARNING/CAUTION/NOTE

Please read this manual and follow its instructions carefully. To emphasize special information, the words **WARNING**, **CAUTION** and **NOTE** have special meanings. Pay special attention to the messages highlighted by these signal words.

WARNING:

Indicates a potential hazard that could result in death or injury.

CAUTION:

Indicates a potential hazard that could result in vehicle damage.

NOTE:

Indicates special information to make maintenance easier or instructions clearer.

WARNING:

This service manual is intended for authorized SUZUKI dealers and qualified service mechanics only. Inexperienced mechanics or mechanics without the proper tools and equipment may not be able to properly perform the services described in this manual. Improper repair may result in injury to the mechanic and may render the vehicle unsafe for the driver and passengers.

WARNING:

For vehicles equipped with a Supplemental Restraint (Air Bag) System:

- Service on and around the air bag system components or wiring must be performed only by an authorized SUZUKI dealer. Refer to “Air Bag System Components and Wiring Location View” under “General Description” in air bag system section in order to confirm whether you are performing service on or near the air bag system components or wiring. Please observe all WARNINGS and “Service Precautions” under “On-Vehicle Service” in air bag system section before performing service on or around the air bag system components or wiring. Failure to follow WARNINGS could result in unintentional activation of the system or could render the system inoperative. Either of these two conditions may result in severe injury.
- If the air bag system and another vehicle system both need repair, SUZUKI recommends that the air bag system be repaired first, to help avoid unintended air bag system activation.
- Do not modify the steering wheel, instrument panel or any other air bag system component (on or around air bag system components or wiring). Modifications can adversely affect air bag system performance and lead to injury.
- If the vehicle will be exposed to temperatures over 93°C (200°F) (for example, during a paint baking process), remove the air bag system components (air bag (inflator) module, sensing and diagnostic module (SDM), seat belt pretensioner (if equipped) beforehand to avoid component damage or unintended activation.

FOREWORD

This manual is a supplement to SQ416/SQ420/SQ625 SERVICE MANUAL. It has been prepared exclusively for the following applicable model.

Applicable model: SQ420WD (GRAND VITARA RHZ Diesel engine model) on and after the following VIN No.

☒JSAFTD82V00100001☒ ~

It described only different servicing information of SQ420WD RHZ engine model as compared with SQ416/SQ420/ SQ625.

Therefore, whenever servicing SQ420WD, consult this service manual first.

And for any section, item or description not found in this service manual, refer to the related manuals below.

When replacing parts or servicing by disassembling, it is recommended to use SUZUKI genuine parts, tools and service materials (lubricant, sealants, etc.) as specified in each description.

All information, illustrations and specifications contained in this literature are based on the latest product information available at the time of publication approval. And used as the main subject of description is the vehicle of standard specifications among others.

Therefore, note that illustrations may differ from the vehicle being actually serviced.

The right is reserved to make changes at any time without notice.

RELATED MANUALS:

Manual Name	Manual No.
SQ416/SQ420/SQ625 Service Manual (Volume 1 and 2)	99500-65D10-XXX
GRAND VITARA SUPPLEMENTARY SERVICE MANUAL	99501-65D30-XXX
SQ416/SQ420/SQ625 Unit Repair Manual (For Manual Transmission, Automatic Transmission, Transfer and Differential.)	99501-65D01-XXX
SQ416/SQ420/SQ625 Wiring Diagram Manual	99512-65D11-015
SQ420WD Supplementary Wiring Diagram Manual	99512-68D10-015

SUZUKI MOTOR CORPORATION

TABLE OF CONTENTS	SECTION
GENERAL INFORMATION	
General Information	0A
Maintenance and Lubrication	0B
HEATING AND AIR CONDITIONING	
Heater and Ventilation	1A
Air Conditioning	1B
STEERING, SUSPENSION, WHEELS AND TIRES	
Power Steering (P/S) System	3B1
Rear Suspension	3E
DRIVE SHAFT/PROPELLER SHAFT	
Front Drive Shaft/Shaft Bearing, Oil Seal	4A2
Propeller Shafts	4B
ENGINE	
Engine General Information and Diagnosis (RHZ Engine With Single-connector ECM)	6
Engine General Information and Diagnosis (RHZ Engine With Triple-connector ECM)	6-1
Engine Mechanical (RHZ engine)	6A3
Engine Cooling	6B
Engine Fuel	6C
Engine and Emission Control System (RHZ engine)	6E3
Cranking System (2.0 kw Reduction Type)	6G
Charging System	6H
Exhaust System	6K
TRANSMISSION, CLUTCH AND DIFFERENTIAL	
Manual Transmission	7A2
Automatic Transmission	7B1
Clutch (Hydraulic Type)	7C1
Differential (Front)	7E
Differential (Rear)	7F
BODY ELECTRICAL SYSTEM	
Instrumentation/Driver Information	8C
Immobilizer Control System	8G

0A
0B
1A
1B
3B1
3E
4A2
4B
6
6-1
6A3
6B
6C
6E3
6G
6H
6K
7A2
7B1
7C1
7E
7F
8C
8G

SECTION 0A

GENERAL INFORMATION

NOTE:

For the descriptions (items) not found in this section, refer to the same section of the Service Manual mentioned in FOREWORD of this manual.

CONTENTS

PRECAUTIONS	0A- 2
General Precautions	0A- 2
IDENTIFICATION INFORMATION	0A- 5
Vehicle Identification Number	0A- 5
Engine Identification Number	0A- 5
Transmission Identification Number	0A- 5
WARNING, CAUTION AND INFORMATION LABELS	0A- 6
FASTENER INFORMATION	0A- 7
Metric Fasteners	0A- 7

PRECAUTIONS

GENERAL PRECAUTIONS

The WARNING and CAUTION below describe some general precautions that you should observe when servicing a vehicle. These general precautions apply to many of the service procedures described in this manual, and they will not necessarily be repeated with each procedure to which they apply.

WARNING:

- Whenever raising a vehicle for service, be sure to follow the instructions under “VEHICLE LIFTING POINTS” on SECTION 0A.
- When it is necessary to do service work with the engine running, make sure that the parking brake is set fully and the transmission is in Neutral (for manual transmission vehicles) or Park (for automatic transmission vehicles). Keep hands, hair, clothing, tools, etc. away from the fan, belts and fuel line between high pressure fuel pump and injectors when the engine is running.
- When it is necessary to run the engine indoors, make sure that the exhaust gas is forced outdoors.
- Do not perform service work in areas where combustible materials can come in contact with a hot exhaust system. When working with toxic or flammable materials (such as gasoline and refrigerant), make sure that the area you work in is well-ventilated.
- To avoid getting burned, keep away from hot metal parts such as the radiator, exhaust manifold, tail-pipe, muffler, etc.
- New and used engine oil can be hazardous. Children and pets may be harmed by swallowing new or used oil. Keep new and used oil and used engine oil filters away from children and pets. Continuous contact with used engine oil has been found to cause [skin] cancer in laboratory animals. Brief contact with used oil may irritate skin. To minimize your exposure to used engine oil, wear a long-sleeve shirt and moisture-proof gloves (such as dishwashing gloves) when changing engine oil. If engine oil contacts your skin, wash thoroughly with soap and water. Launder any clothing or rags if wet with oil, recycle or properly dispose of used oil and filters.
- Make sure the bonnet is fully closed and latched before driving. If it is not, it can fly up unexpectedly during driving, obstructing your view and resulting in an accident.

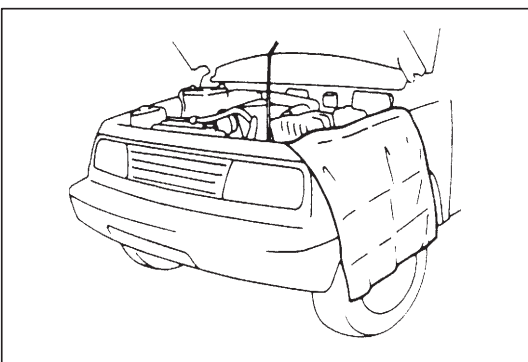

CAUTION:

- Before starting any service work, cover fenders, seats and any other parts that are likely to get scratched or stained during servicing. Also, be aware that what you wear (e.g, buttons) may cause damage to the vehicle's finish.

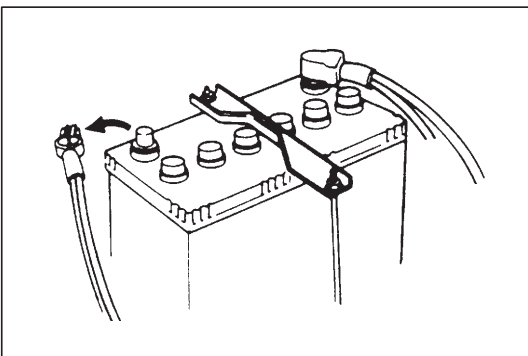

- When performing service to electrical parts that does not require use of battery power, disconnect the negative cable of the battery.

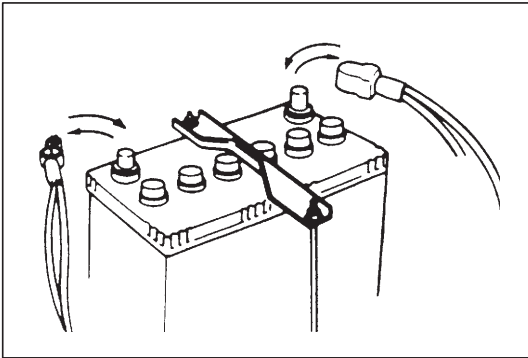

- When removing the battery, be sure to disconnect the negative cable first and then the positive cable. When reconnecting the battery, connect the positive cable first and then the negative cable, and replace the terminal cover.

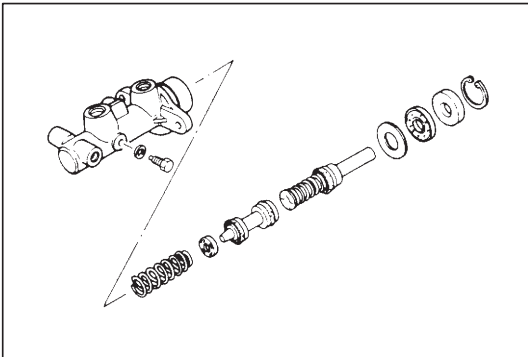

- When removing parts that are to be reused, be sure to keep them arranged in an orderly manner so that they may be reinstalled in the proper order and position.

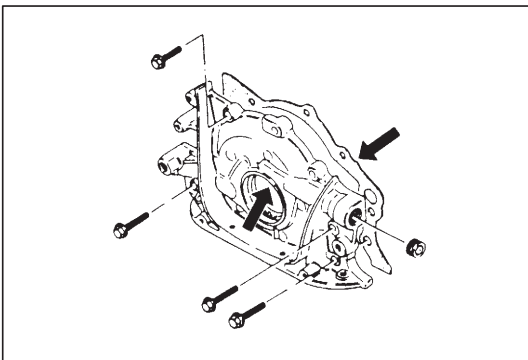

- Whenever you use oil seals, gaskets, packing, O-rings, locking washers, split pins, self-locking nuts, and certain other parts as specified, be sure to use new ones. Also, before installing new gaskets, packing, etc., be sure to remove any residual material from the mating surfaces.

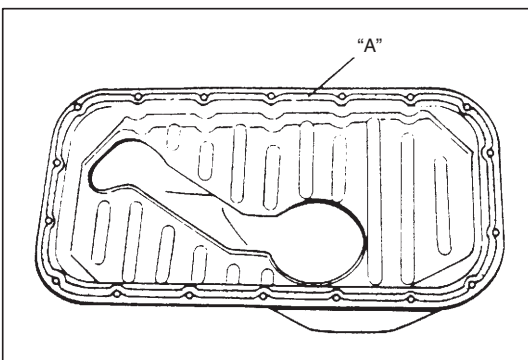

- Make sure that all parts used in reassembly are perfectly clean.
- When use of a certain type of lubricant, bond or sealant is specified, be sure to use the specified type.

“A”: Sealant 99000-31150

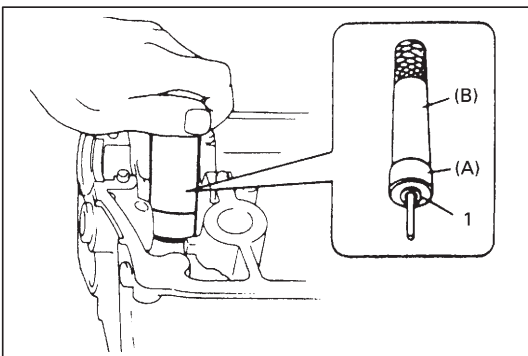

- Be sure to use special tools when instructed.

Special Tool

(A): 09917-98221

(B): 09916-58210

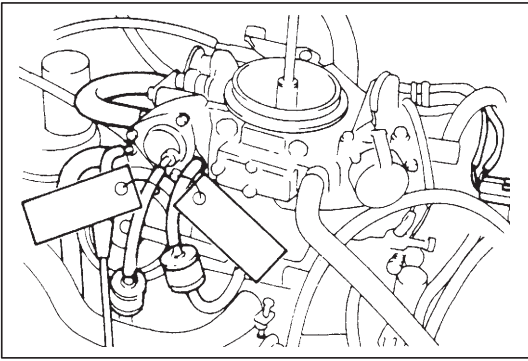

- When disconnecting vacuum hoses, attach a tag describing the correct installation positions so that the hoses can be re-installed correctly.

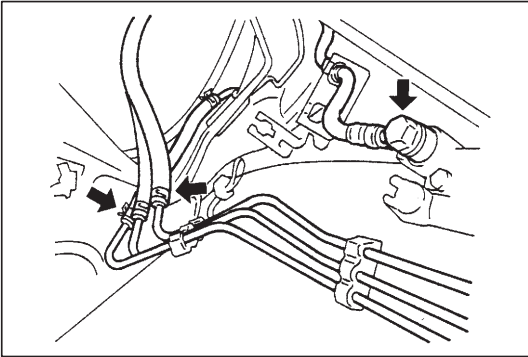

- After servicing fuel, oil, coolant, vacuum, exhaust or brake systems, check all lines related to the system for leaks.

- For vehicles equipped with fuel injection systems, never disconnect the fuel line between the fuel pump and injector within 30 sec. after engine stop, or fuel can be sprayed out under pressure.

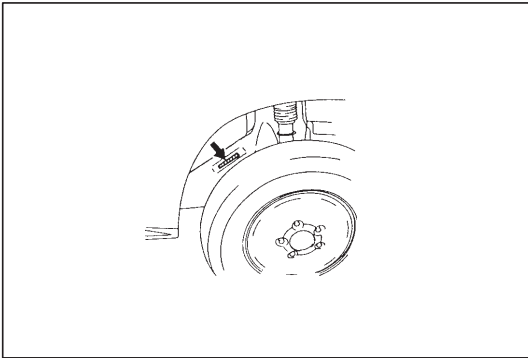

IDENTIFICATION INFORMATION

VEHICLE IDENTIFICATION NUMBER

The number is punched on the chassis inside the tire housing on the right front side.

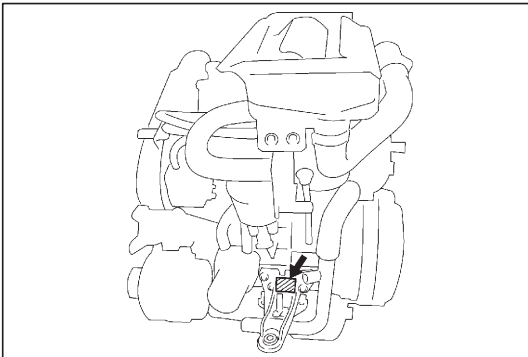

ENGINE IDENTIFICATION NUMBER

The number is punched on the cylinder block.

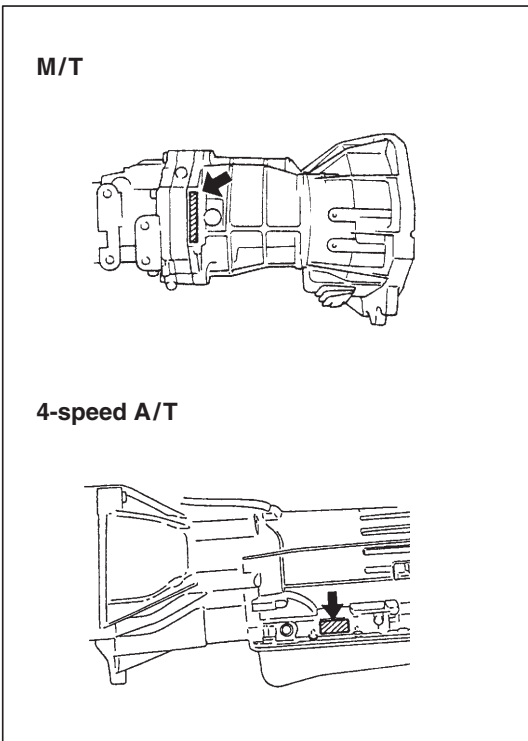

TRANSMISSION IDENTIFICATION NUMBER

The number is located on the transmission case.

WARNING, CAUTION AND INFORMATION LABELS

The figure below shows main labels among others that are attached to vehicle component parts. When servicing and handling parts, refer to WARNING/CAUTION instructions printed on labels. If any WARNING/CAUTION label is found stained or damaged, clean or replace it as necessary.

NOTE:

Air bag CAUTION/WARNING labels are attached on the vehicle equipped with air bag system only.

1. Air bag label
2. Smoke level label
3. Air bag label on sun visor
4. Radiator cooling fan label
5. Degassing tank cap (radiator cap) label
6. Transfer label
7. Air bag label on wire harness
8. Air bag label on passenger air bag (inflator) module
9. Seat belt pretensioner label on retractor
10. Air bag label on SDM
11. Air bag label on driver air bag (inflator) module
12. Air bag label on combination switch and contact coil assembly
13. Air bag label on steering column

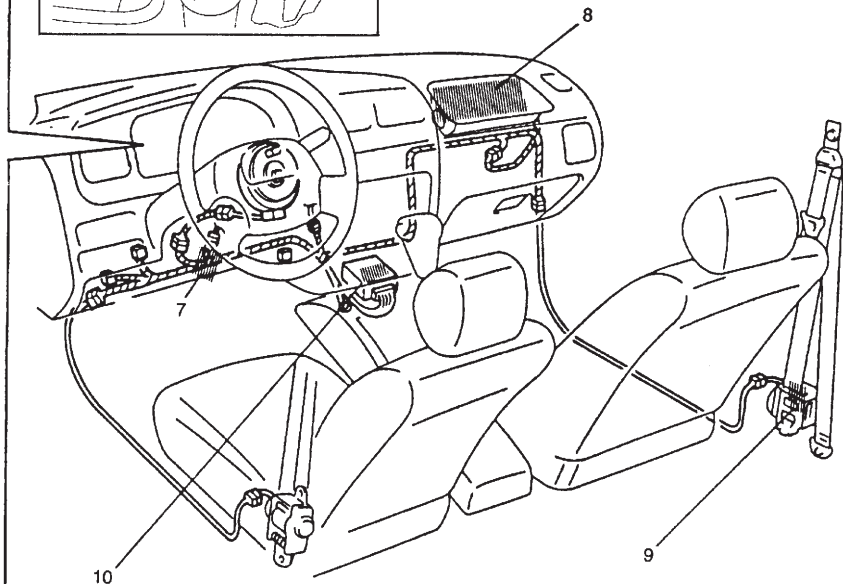
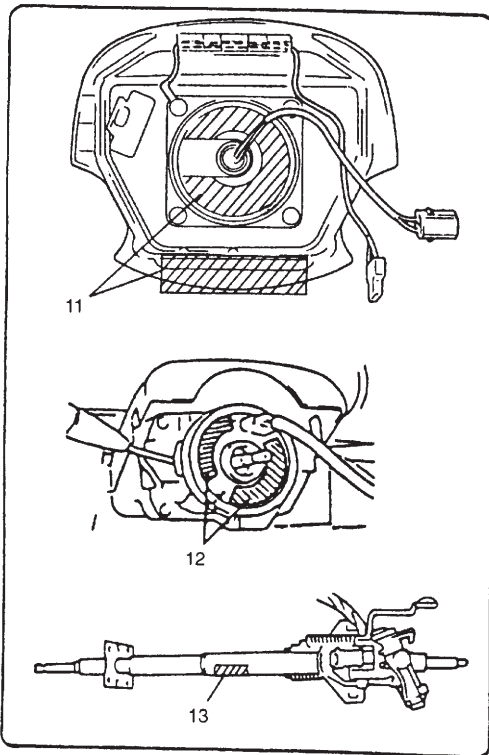
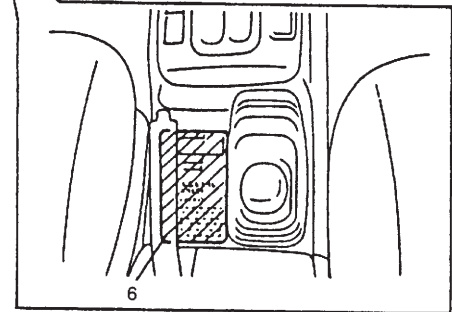
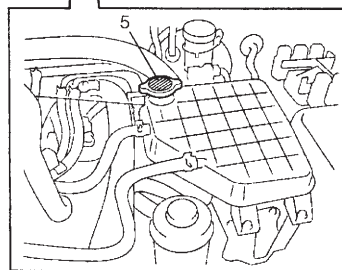
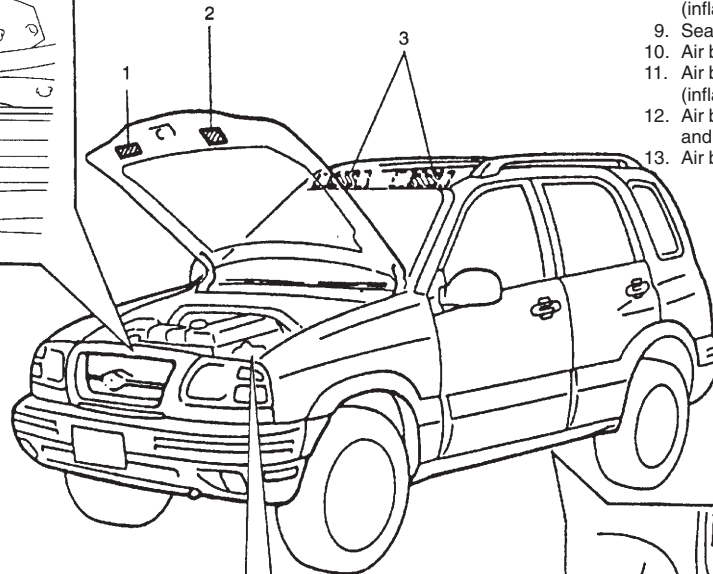
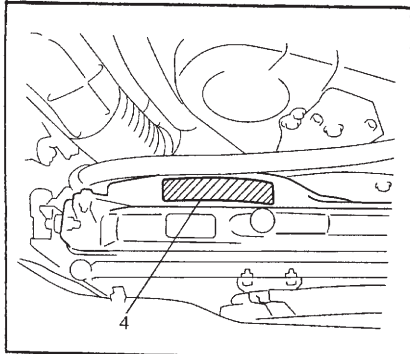

FASTENER INFORMATION

METRIC FASTENERS

Most of the fasteners used for this vehicle are metric fasteners. When replacing any fasteners, it is most important that replacement fasteners be the correct diameter, thread pitch and strength.

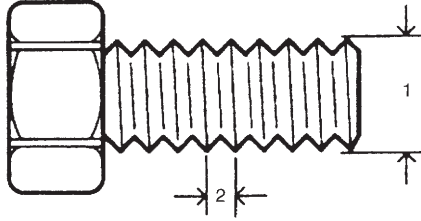

1. Diameter
2. Pitch

CAUTION:

Note that both ISO and JIS type bolts and nuts are used for the engine assembly and related parts. Even when the diameter of the thread is the same, its pitch may vary between these two types. Installing a mismatched bolt or nut will cause damage to the thread. As the first step, make sure to tighten it by hand temporarily and if it feels tight, check the thread pitch for correct matching.

SECTION 0B

MAINTENANCE AND LUBRICATION

WARNING:

For vehicles equipped with Supplemental Restraint (Air Bag) System:

- Service on and around the air bag system components or wiring must be performed only by an authorized SUZUKI dealer. Refer to “Air Bag System Components and Wiring Location View” under “General Description” in air bag system section in order to confirm whether you are performing service on or near the air bag system components or wiring. Please observe all WARNINGS and “Service Precautions” under “On-Vehicle Service” in air bag system section before performing service on or around the air bag system components or wiring. Failure to follow WARNINGS could result in unintentional activation of the system or could render the system inoperative. Either of these two conditions may result in severe injury.
- Technical service work must be started at least 90 seconds after the ignition switch is turned to the “LOCK” position and the negative cable is disconnected from the battery. Otherwise, the system may be activated by reserve energy in the Sensing and Diagnostic Module (SDM).

NOTE:

For the descriptions (items) not found in this section, refer to the same section of the Service Manual mentioned in FOREWORD of this manual.

CONTENTS

MAINTENANCE SCHEDULE	0B- 2
Maintenance Schedule Under Normal Driving Conditions	0B- 2
Maintenance Recommended Under Severe Driving Conditions	0B- 4
MAINTENANCE SERVICE	0B- 5
Engine	0B- 5
Fuel System	0B- 9
Chassis and Body	0B-11
RECOMMENDED FLUIDS AND LUBRICANTS	0B-13

MAINTENANCE SCHEDULE

MAINTENANCE SCHEDULE UNDER NORMAL DRIVING CONDITIONS

Interval: This interval should be judged by odometer reading or months, whichever comes first.	This table includes services as scheduled up to 90,000 km (54,000 miles) mileage. Beyond 90,000 km (54,000 miles), carry out the same services at the same intervals respectively.						
	Km (x 1,000)	15	30	45	60	75	90
	Miles (x 1,000)	9	18	27	36	45	54
	Months	12	24	36	48	60	72
1. ENGINE							
1-1. Accessory drive belt	-	-	I	-	-	-	R
1-2. Camshaft timing belt	Replace every 150,000 km (90,000 miles).						
1-3. Engine oil and oil filter	Replace every 20,000 km (12,000 miles) or 16 months.						
1-4. Engine coolant	-	-	R	-	-	-	R
1-5. Exhaust system	-	I	-	I	-	-	I
1-6. Heater (Glow) plugs	Inspect every 120,000 km (72,000 miles) or 96 months.						
3. FUEL SYSTEM							
3-1. Air cleaner filter	I	I	R	I	I	-	R
3-2. Fuel lines	-	I	-	I	-	-	I
3-3. Fuel filter	Replace every 60,000 km (36,000 miles).						
	Drain water every 20,000 km (12,000 miles).						
3-4. Fuel tank	-	-	I	-	-	-	I

Interval: This interval should be judged by odometer reading or months, whichever comes first.	This table includes services as scheduled up to 90,000 km (54,000 miles) mileage. Beyond 90,000 km (54,000 miles), carry out the same services at the same intervals respectively.						
	Km (x 1,000)	15	30	45	60	75	90
	Miles (x 1,000)	9	18	27	36	45	54
	Months	12	24	36	48	60	72
CHASSIS AND BODY							
6-1. Clutch (pedal and fluid level)		-	I	-	I	-	I
6-2.	Brake discs and pads (thickness, wear, damage)	I	I	I	I	I	I
	Brake drums and shoes (wear, damage)	-	I	-	I	-	I
6-3. Brake hoses and pipes (leakage, damage, clamp)		-	I	-	I	-	I
6-4. Brake fluid		-	R	-	R	-	R
6-5. Brake lever and cable (damage, stroke, operation)		Inspect at first 15,000 km (9,000 miles) only					
6-6. Tires (wear, damage, rotation)		I	I	I	I	I	I
6-7. Wheel discs (damage)		I	I	I	I	I	I
6-8. Suspension system (tightness, damage, rattle, breakage)		-	I	-	I	-	I
6-9. Propeller shafts and drive shafts		-	-	I	-	-	I
6-10. Manual transmission oil (leakage, level) (I: 1st 15,000 km only)		I	-	R	-	-	R
6-11. Automatic transmission	Fluid level	-	I	-	I	-	I
	Fluid change	Replace every 165,000 km (99,000 miles)					
	Fluid hose	-	-	-	R	-	-
6-12. Transfer oil (leakage, level)		I	-	I	-	I	-
6-13. Differential oil (leakage, level) (R: 1st 15,000 km only)		R or I	-	I	-	I	-
6-14. Steering system (tightness, damage, breakage, rattle)		-	I	-	I	-	I
6-15. Power steering (if equipped)		I	I	I	I	I	I
6-16. All latches, hinges and locks		-	I	-	I	-	I
6-17. Air conditioning filter (if equipped)		-	I	R	-	I	R

NOTES:

“R”: Replace or change

“I” : Inspect and correct, replace or lubricate if necessary

Some maintenance items are required to be serviced at times other than the regular maintenance times shown at the top of above table. These items can be serviced at an earlier service opportunity according to customer’s maintenance convenience. Their next maintenance service should be done within the specified period.

MAINTENANCE RECOMMENDED UNDER SEVERE DRIVING CONDITIONS

If the vehicle is usually used under the conditions corresponding to any severe condition code given below, it is recommended that applicable maintenance operation be performed at the particular interval as given in the chart below.

Severe condition code

- | | |
|--|--|
| A – Repeated short trips | F – Leaded fuel use |
| B – Driving on rough and/or muddy roads | G – Town use/Towing a trailer/Sustained high speed driving/Hot climates, frequently above 30°C(86°F)/Cold climates, frequently below –15°C (5°F)/Low quality lubricants or fuel |
| C – Driving on dusty roads | |
| D – Driving in extremely cold weather and/or salted roads | H – Trailer towing (if admitted) |
| E – Repeated short trips in extremely cold weather | |

Severe Condition Code	Maintenance	Maintenance Operation	Maintenance Interval
- B C D - - - -	ITEM 1-1 Accessory drive belt (V-rib belt)	I	Every 15,000 km (9,000 miles) or 12 months
		R	Every 45,000 km (27,000 miles) or 36 months
A - C D E - G -	ITEM 1-2 Camshaft timing belt	R	Every 120,000 km (72,000 miles)
A - C D E F G H	ITEM 1-3 Engine oil and oil filter	R	Every 5,000 km (3,000 miles) or 4 months
- B - - - - - -	ITEM 1-5 Exhaust pipe mountings	I	Every 15,000 km (9,000 miles) or 12 months
- - C - - - - -	ITEM 3-1 Air cleaner filter*1	I	Every 2,500 km (1,500 miles)
		R	Every 30,000 km (18,000 miles) or 24 months
- - C - - - G -	ITEM 3-3 Fuel filter	R	Every 10,000 km (6,000 miles) or 8 months
- B C D - - - H	ITEM 6-7 Wheel bearing	I	Every 15,000 km (9,000 miles) or 12 months
- B - - - - - -	ITEM 6-8 Suspension bolts and nuts	T	Every 15,000 km (9,000 miles) or 12 months
- B - D E - - H	ITEM 6-9 Propeller shafts and drive shafts	I	Every 15,000 km (9,000 miles) or 12 months
- B - - E - - H	ITEM 6-10, 6-12, 6-13 Manual transmission, transfer and differential oil	R	Every 30,000 km (18,000 miles) or 24 months
- B - - E - - H	ITEM 6-11 Automatic transmission fluid	R	Every 30,000 km (18,000 miles) or 24 months
- - C D - - - -	ITEM 6-17 Air conditioning filter *2 (if equipped)	I	Every 15,000 km (9,000 miles) or 12 months
		R	Every 45,000 km (27,000 miles) or 36 months

NOTES:

“I” : Inspect and correct, replace or lubricate if necessary

“R” : Replace or change

“T” : Tighten to the specified torque

*1 : Inspect or replace more frequently if necessary.

*2 : Clean or replace more frequently if the air from the air conditioning decreases.

MAINTENANCE SERVICE

ENGINE

ITEM 1-1

Accessory Drive Belt Inspection and Replacement

WARNING:

All inspection and replacement are to be performed with **ENGINE NOT RUNNING.**

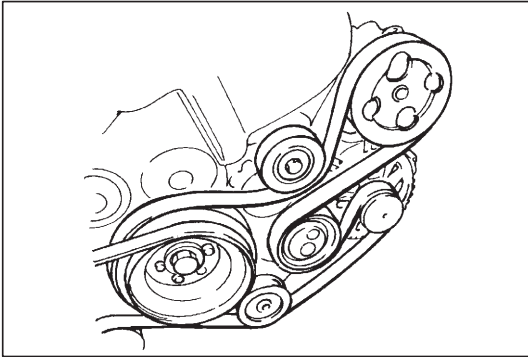

Inspection

- 1) Disconnect negative cable at battery.
- 2) Inspect belt for cracks, cuts, deformation, wear and cleanliness using mirror under enough lighting.
If any defect exists, replace.

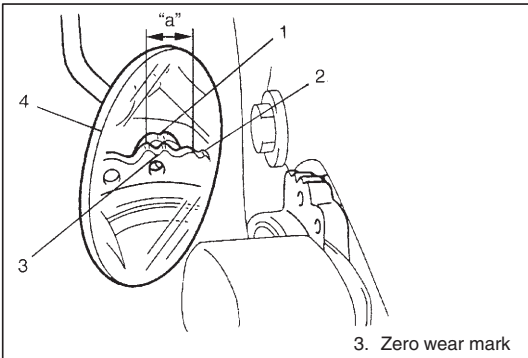

- 3) Check that belt wear check mark (1) (tension indicator) is within range "a" using mirror (4) under enough lighting.
If wear check mark (1) is aligned with maximum wear mark (2) or out of range "a" passing mark (2), replace accessory drive belt with a new one.
- 4) Connect negative cable to battery.

Replacement

Replace belt with a new one referring to GENERATOR in section 6H.

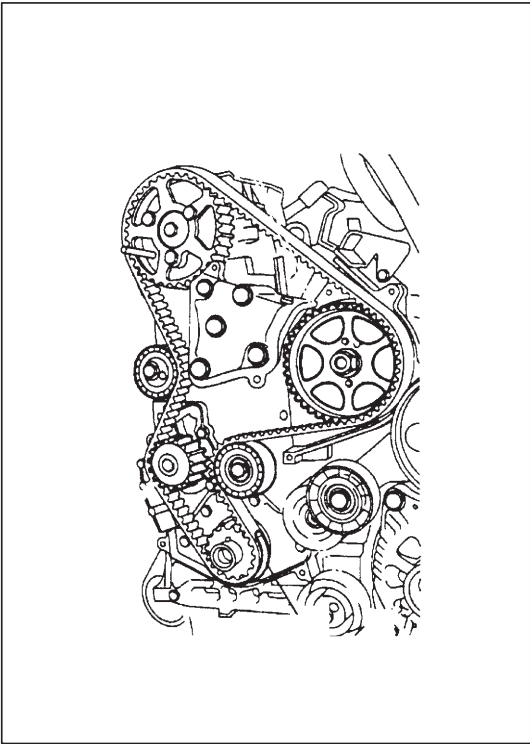

ITEM 1-2

Camshaft Timing Belt Replacement

Replace belt with new one. Refer to “Timing Belt” in SECTION 6A3 for replacement procedure.

CAUTION:

- Do not bend or twist timing belt.
- Do not allow timing belt to come into contact with oil, water, etc.

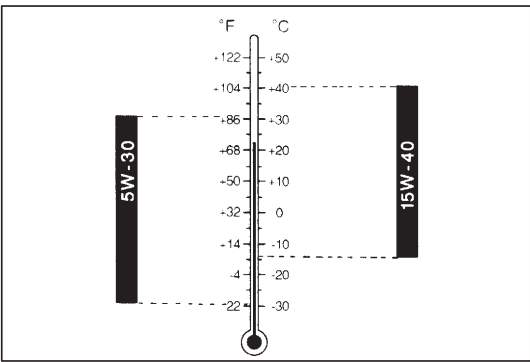

ITEM 1-3

Engine Oil and Oil Filter Change

It is recommended to use the following engine oil or higher quality level oils.

5W-30 : API CF (except CF-2) or ACEA B3-98

15W-40 : API SG/CF (except CF-2) or ACEA B2-96

Select the appropriate oil viscosity according to the left chart.

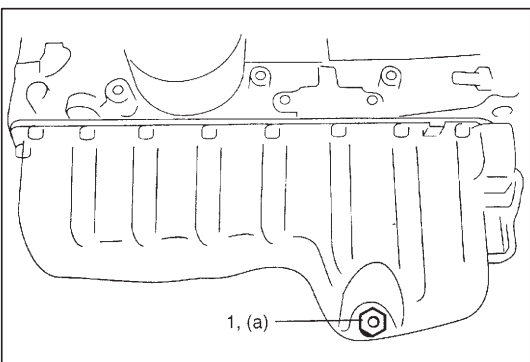

Before draining engine oil, check engine for oil leakage. If any evidence of leakage is found, make sure to correct defective part before performing the following work.

- 1) Drain engine oil by removing drain plug (1).
- 2) After draining oil, wipe drain plug clean. Reinstall drain plug, and tighten it securely as specified below.

Tightening Torque

(a): 34 N·m (3.4 kg-m, 25.0 lb-ft)

- 3) Loosen oil filter by using oil filter wrench (Special tool).

Special Tool

(A): 09915-46510

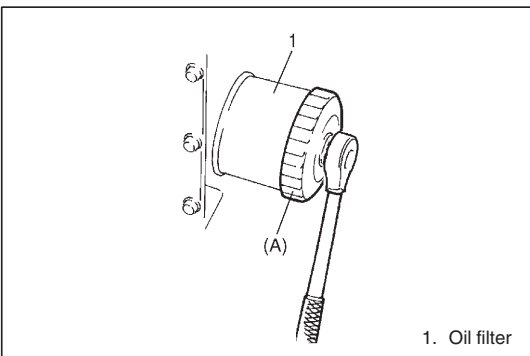

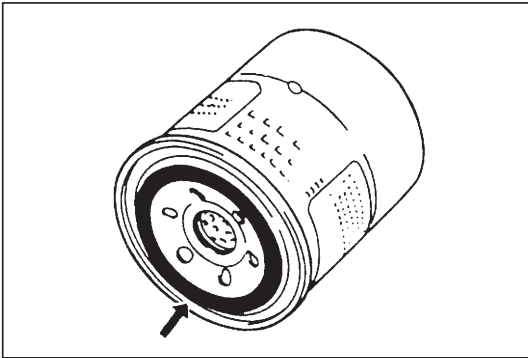

- 4) Apply engine oil to new oil filter O-ring.
- 5) Screw new filter on oil filter stand by hand.

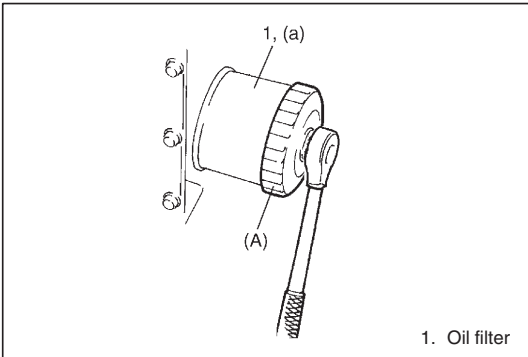

- 6) Tighten filter to specified torque.

Special Tool

(A): 09915-46510

Tightening Torque

(a): 14 N·m (1.4 kg-m, 10.5 lb-ft)

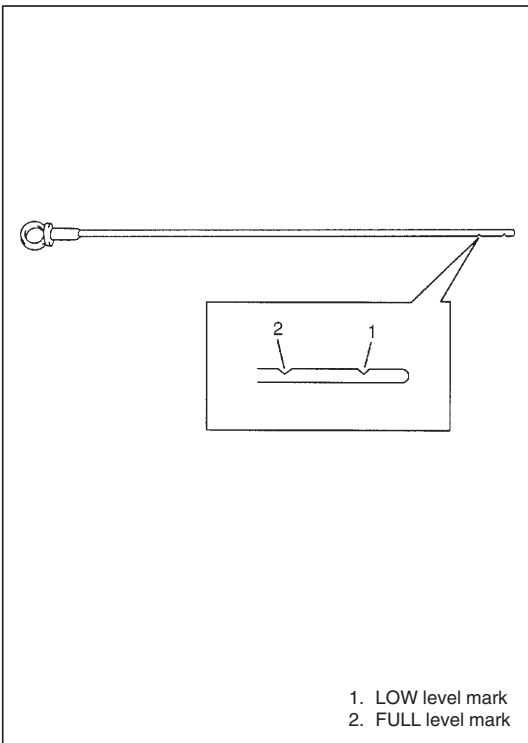

- 7) Replenish oil until oil level is brought to FULL level mark on dipstick. (about 4.75 liters or 10.0/8.4 US/Imp pt.).

NOTE:

Note that amount of oil required when actually changing oil may somewhat differ from this data depending on various conditions (temperature, viscosity, etc.)

- 8) Start engine and run it for three minutes. Stop it and wait another 5 minutes before checking oil level. Add oil, as necessary, to bring oil level to FULL level mark on dipstick.
- 9) Check oil filter and drain plug for oil leakage.

ITEM 1-4

Engine Coolant Change

WARNING:

To help avoid danger of being burned, do not remove degassing tank cap while engine and radiator are still hot. Scalding fluid and steam can be blown out under pressure if cap is taken off too soon.

CAUTION:

When changing engine coolant, use mixture of 50% water and 50% ethylene-glycol base coolant (Anti-freeze/Anti-corrosion coolant) for the market where ambient temperature falls lower than -16°C (3°F) in winter and mixture of 70% water and 30% ethylene-glycol base coolant for the market where ambient temperature doesn't fall lower than -16°C (3°F).

Even in a market where no freezing temperature is anticipated, mixture of 70% water and 30% ethylene-glycol base coolant should be used for the purpose of corrosion protection and lubrication.

- 1) Remove degassing tank cap when engine is cool.

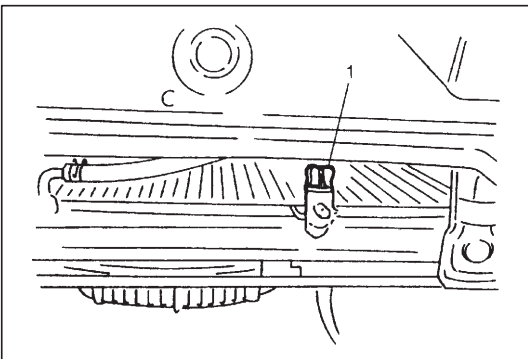

- 2) Loosen radiator drain plug (1) to drain coolant.
- 3) Tighten drain plug securely.

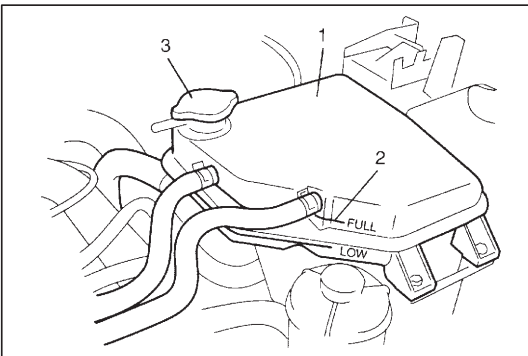

- 4) Fill cooling system with specified coolant through degassing tank filler inlet, up to "FULL" level mark (2) on degassing tank (1).
- 5) Loosen bleed screw on thermostat cap to bleed air and tighten it after confirmation of overflow.
- 6) Run engine with replenishing coolant, until radiator upper hose is hot.
- 7) Add coolant as necessary until coolant reaches "FULL" level mark on degassing tank.
Reinstall degassing tank cap (3).
Refer to SECTION 6B of this manual for "Coolant Capacity".

ITEM 1-5

Exhaust System Inspection

WARNING:

To avoid danger of being burned, do not touch exhaust system when it is still hot.

Any service on exhaust system should be performed when it is cool.

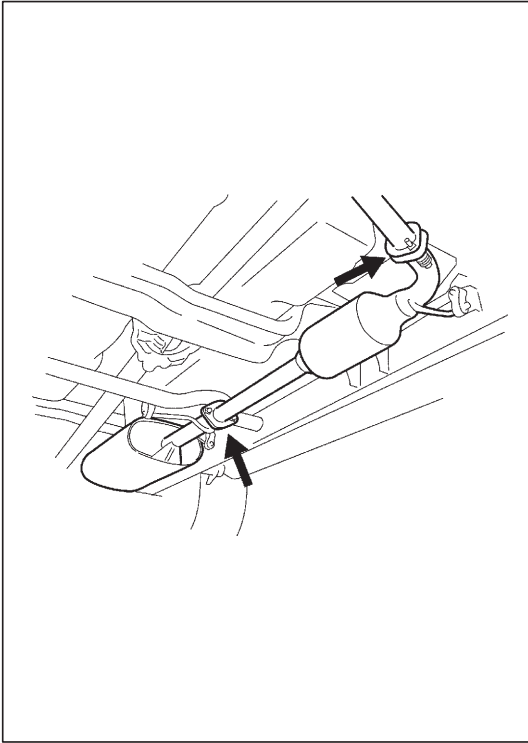

Check exhaust system as follows:

- Check rubber mountings for damage and deterioration.
- Check exhaust system for leakage, loose connections, dents, and damages.

If bolts or nuts are loose, tighten them to specification.

Refer to SECTION 6K for torque specification of bolts and nuts.

- Check nearby body areas for damaged, missing or mispositioned parts, open seams, holes, loose connections or other defects which could permit exhaust fumes to seep into vehicle.
- Make sure that exhaust system components have enough clearance from underbody to avoid overheating and possible damage to floor carpet.
- Any defects should be fixed at once.

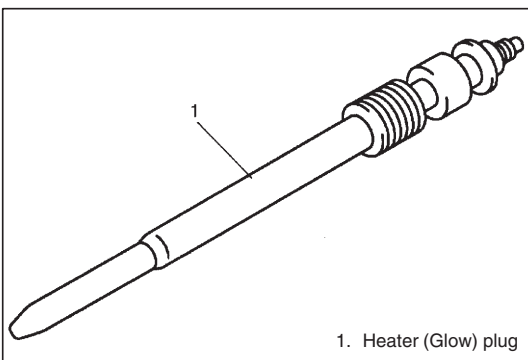

1. Heater (Glow) plug

ITEM 1-6

Heater (Glow) Plugs Inspection

Check for external damage such as deformation, scratch, crack, etc.

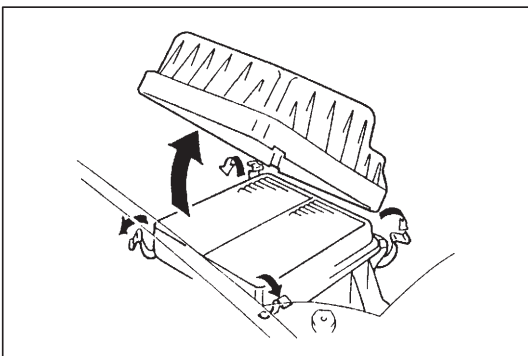

FUEL SYSTEM

ITEM 3-1

Air Cleaner Filter Replacement

- 1) Unclamp air cleaner case clamps.
- 2) Replace air cleaner filter with new one.
- 3) Clamp case securely.

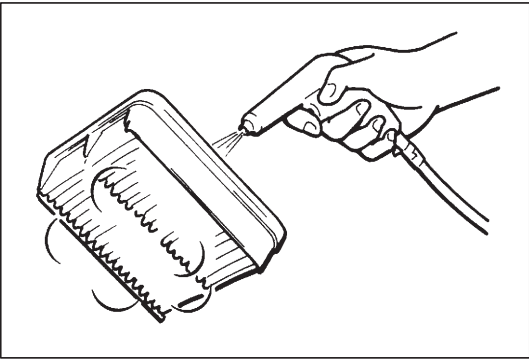

Air Cleaner Filter Inspection

- 1) Visually check that air cleaner filter is not excessively dirty, damaged or oily.
- 2) Clean filter with compressed air from air outlet side of filter (i.e., the side facing up when installed).

ITEM 3-2

Fuel Lines and Connections Inspection

- 1) Visually inspect fuel lines and connections for evidence of fuel leakage, hose cracking and damage. Make sure all clamps are secure.
Repair leaky joints, if any.
Replace hoses that are suspected of being cracked.

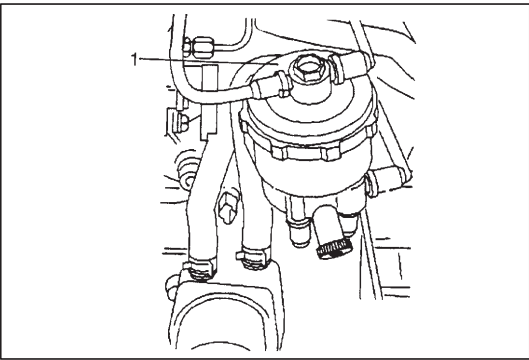

ITEM 3-3

Fuel Filter Replacement

WARNING:

This work must be performed in a well ventilated area and away from any open flames (such as gas hot water heaters).

Replace fuel filter in fuel filter assembly (1) with new one referring to FUEL FILTER in SECTION 6C.

Water Draining of Fuel Filter

Bleed fuel filter of water referring to FUEL FILTER in SECTION 6C.

ITEM 3-4

Fuel Tank Inspection

Check fuel tank for damage, cracks, fuel leakage, corrosion and tank bolts looseness.
If a problem is found, repair or replace.

CHASSIS AND BODY

ITEM 6-10

Manual Transmission Oil Inspection and Change Inspection

- 1) Inspect transmission case for evidence of oil leakage.
Repair leaky point if any.
- 2) Make sure that vehicle is placed level for oil level check.
- 3) Remove level plug of transmission.
- 4) Check oil level.
Oil level can be checked roughly by means of level plug hole. That is, if oil flows out of level plug hole or if oil level is found up to hole when level plug is removed, oil is properly filled. If oil is found insufficient, pour specified amount of specified oil.
- 5) Tighten level plug to specified torque.
Refer to Section 7A2 for installation and tightening torque.

Change

Change transmission oil with new specified oil referring to Section 7A2.

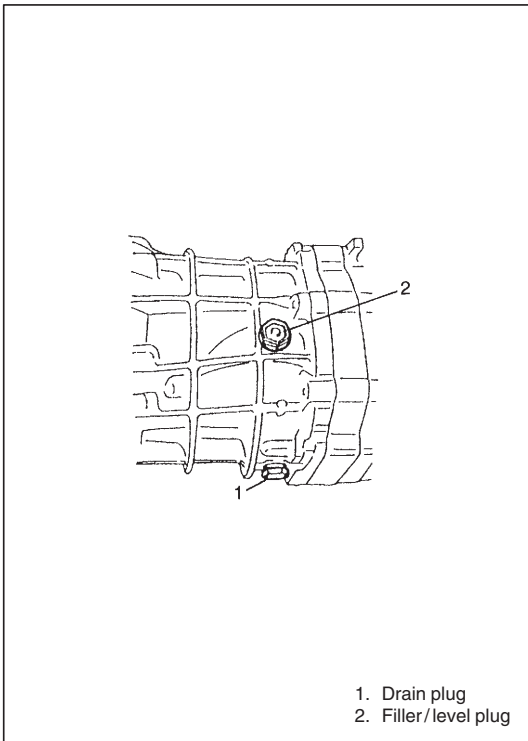

ITEM 6-11

Automatic Transmission Fluid Inspection and Change Inspection

- 1) Inspect transmission case for evidence of fluid leakage.
Repair leaky point, if any.
- 2) Make sure that vehicle is placed level for fluid level check.
- 3) Check fluid level.
For fluid level checking procedure, refer to On-vehicle service in Section 7B1 and be sure to perform it under specified conditions. If fluid level is low, replenish specified fluid.

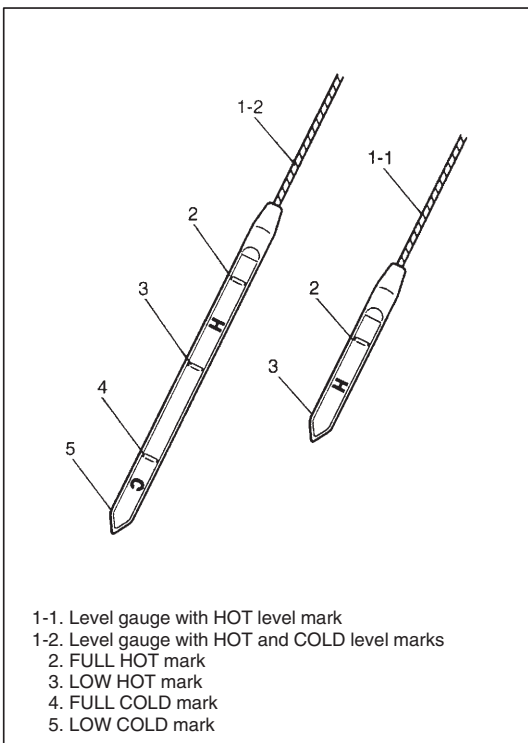

Change

- 1) Inspect transmission case for evidence of fluid leakage.
Repair leaky point, if any.
- 2) Make sure that vehicle is placed level for fluid level check.
- 3) Change fluid. For its procedure, refer to On-vehicle service in Section 7B1.

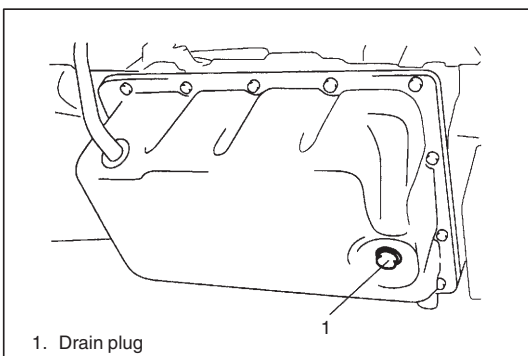

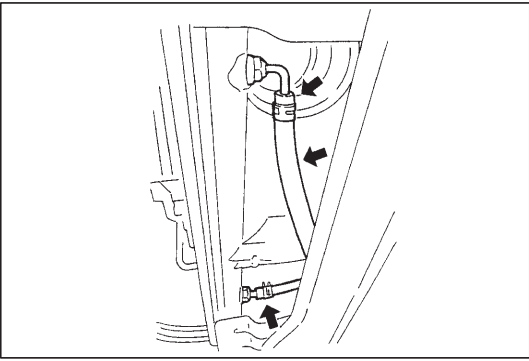

Fluid cooler hose change

Replace inlet and outlet hoses of cooler hose and their clamps. For replacement procedure, refer to On-vehicle service in Section 7B1.

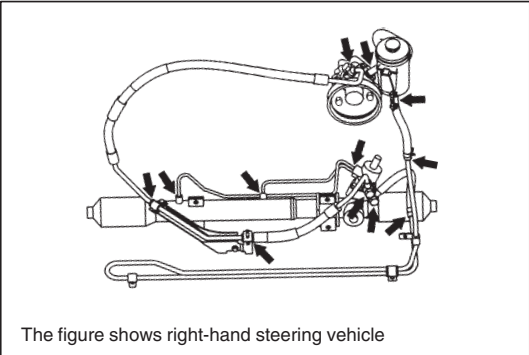

ITEM 6-15

Power Steering (P/S) System Inspection (if equipped)

- 1) Visually check power steering system for fluid leakage and hose for damage and deterioration.
Repair or replace defective parts, if any.

- 2) With engine stopped, check fluid level indicated on fluid tank, which should be between MAX and MIN marks. If it is lower than MIN, fill fluid up to MAX mark.

NOTE:

- Be sure to use an equivalent of DEXRON®-II or DEXRON®-III for P/S fluid.
- Fluid level should be checked when fluid is cool.

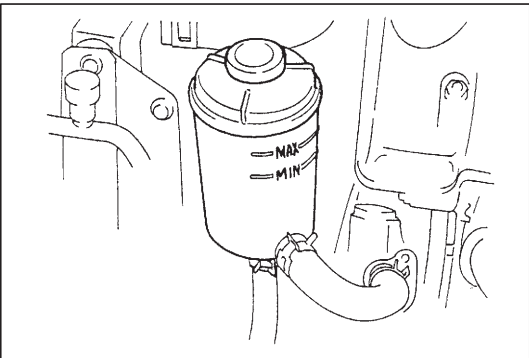

- 3) Visually check pump drive belt for cracks and wear.
- 4) Check belt for tension, referring to item 1-1.
If necessary, have belt adjusted or replaced.

RECOMMENDED FLUIDS AND LUBRICANTS

Engine oil	Minimum quality level required is ; 5W-30 : API CF (except CF-2) or ACEA B3-98 15W-40: API SG/CF (except CF-2) or ACEA B2-96 (Refer to engine oil viscosity chart in item 1-3)
Engine coolant	Ethylene-glycol base coolant ("Antifreeze/Anticorrosion coolant")
Brake fluid	DOT 3
Manual transmission oil	Refer to Section 7A or 7A2.
Transfer oil	
Differential oil (front & rear)	Refer to Section 7E or 7F.
Automatic transmission fluid and Power steering fluid	Refer to Section 3B1 or 7B1.
Door hinges	Engine oil or water resistance chassis grease
Hood latch assembly	
Key lock cylinder	Spray lubricant

SECTION 1A

HEATER AND VENTILATION

1A

WARNING:

For vehicles equipped with Supplement Restraint (Air Bag) System

- Service on and around the air bag system components or wiring must be performed only by an authorized SUZUKI dealer. Refer to “Air Bag System Components and Wiring Location View” under “General Description” in air bag system section in order to confirm whether you are performing service on or near the air bag system components or wiring. Please observe all WARNINGS and “Service Precautions” under “On-Vehicle Service” in air bag system section before performing service on or around the air bag system components or wiring. Failure to follow WARNINGS could result in unintentional activation of the system or could render the system inoperative. Either or these two conditions may result in severe injury.
- Technical service work must be started at least 90 seconds after the ignition switch is turned to the “LOCK” position and the negative cable is disconnected from the battery. Otherwise, the system may be activated by reserve energy in the Sensing and Diagnostic Module (SDM).

NOTE:

- For the descriptions (items) not found in this section, refer to the same section of the Service Manual mentioned in the FOREWORD of this manual.

CONTENTS

GENERAL DESCRIPTION	1A-2
Supplementary heater	1A-2
DIAGNOSIS	1A-2
Diagnosis Table	1A-2
Wiring Circuit	1A-3
Supplementary Heater System Operation	1A-3
ON-VEHICLE SERVICE	1A-4
Supplementary Heater	1A-4
Supplementary Heater relay	1A-4
Radiator Fan Signal Relay	1A-5
Supplementary Heater Switch	1A-5

GENERAL DESCRIPTION

SUPPLEMENTARY HEATER

The supplementary heater which is operated by electricity is located in the heater unit near by the conventional type heater core and adds more heat to the air.

The supplementary heater is designed to be turned off while the radiator fan is in operation even though the supplementary heater switch is in ON position by triggering the radiator fan signal relay.

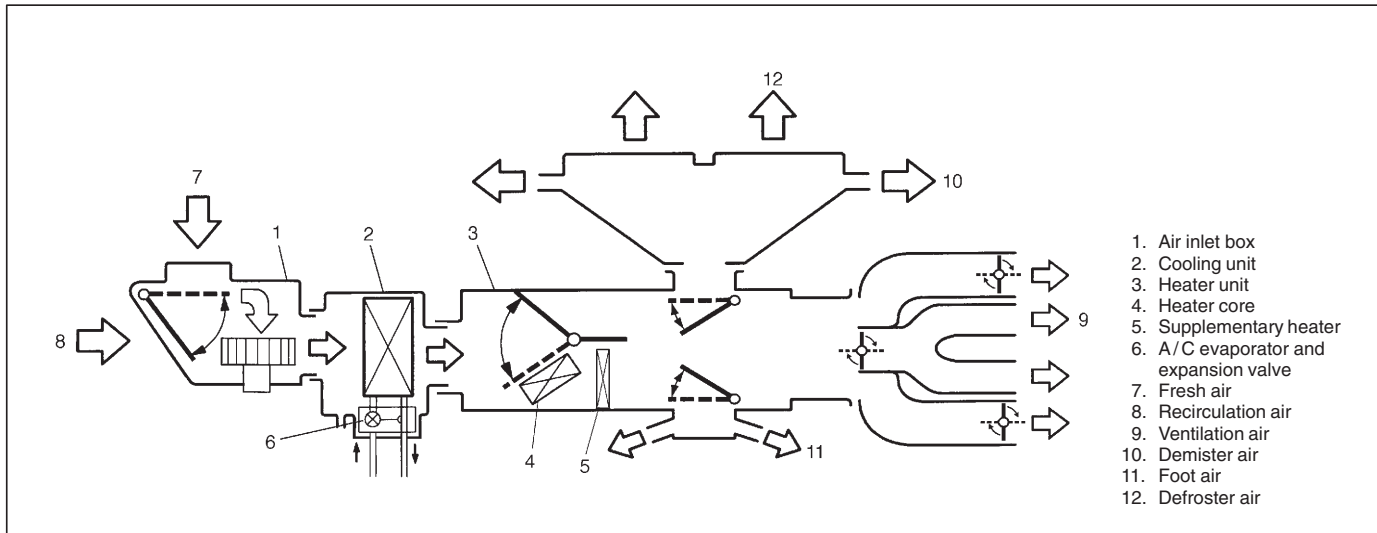

DIAGNOSIS

DIAGNOSIS TABLE

Condition	Possible cause	Inspection/correction
Supplementary heater won't operate with its switch ON	<ul style="list-style-type: none"> ● Fuses blown ● Supplementary heater switch faulty ● Supplementary heater relay faulty ● Radiator fan signal relay faulty ● Supplementary heater faulty ● Blower motor switch faulty ● Indicator lamp burn out 	<p>Check for short circuit to ground and replace fuses.</p> <p>Check supplementary heater switch.</p> <p>Check supplementary heater relay.</p> <p>Check radiator fan signal relay.</p> <p>Check supplementary heater.</p> <p>Check blower motor switch. (Refer to HEATER CONTROL LEVER ASSEMBLY in this section)</p> <p>Repair supplementary heater switch</p>
Supplementary heater won't turn OFF when radiator or condenser fan are in operation (But switch remain ON)	<ul style="list-style-type: none"> ● Radiator fan signal relay faulty ● Wiring or grounding faulty 	<p>Check radiator fan signal relay.</p> <p>Check "Lg" circuit, "B" circuit and grounding.</p>

WIRING CIRCUIT

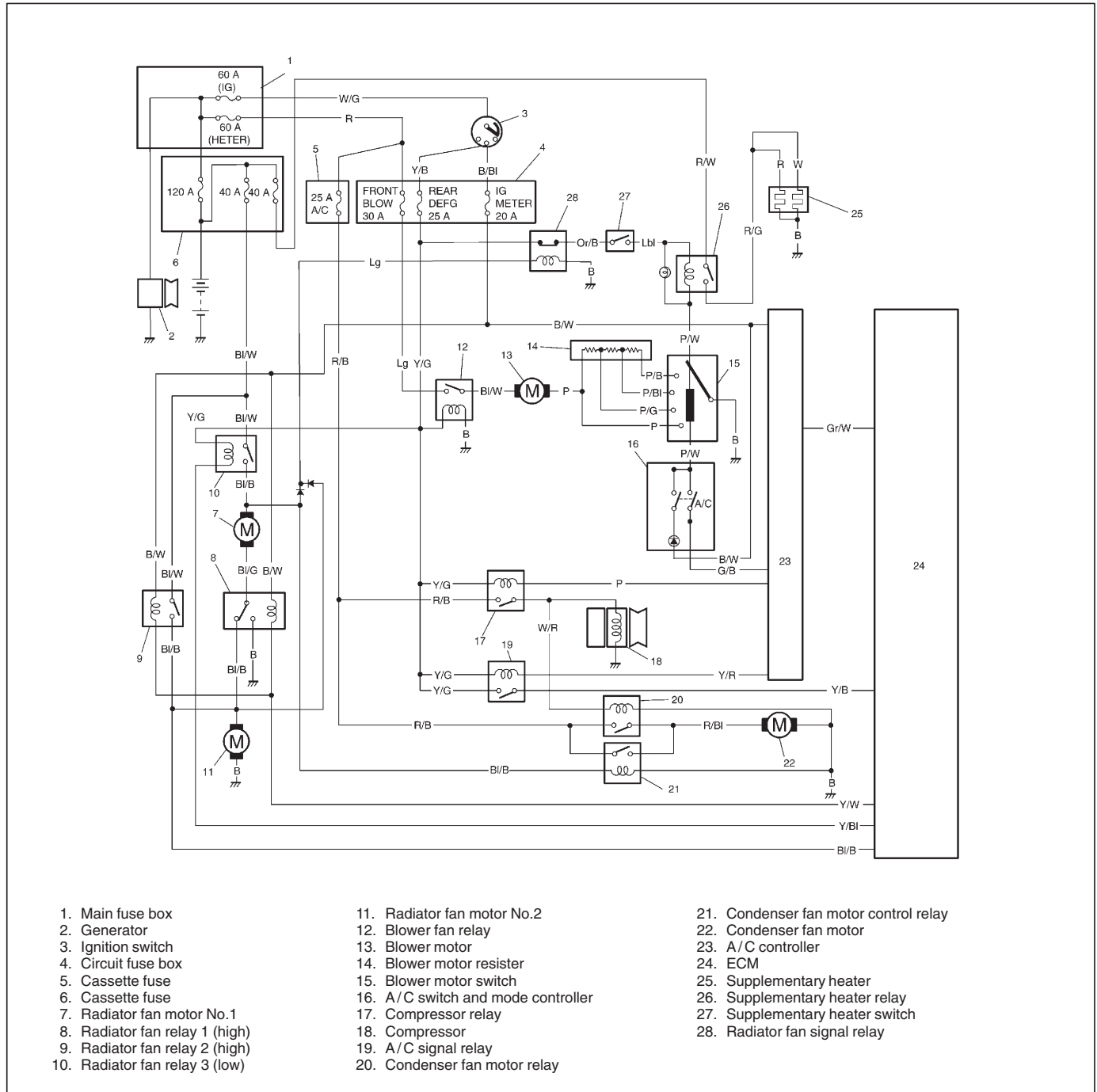

SUPPLEMENTARY HEATER SYSTEM OPERATION

- The supplementary heater relay (26) is turned on when both the radiator signal relay (28) and supplementary heater switch (27) are turned on.
- The radiator fan signal relay (28) is kept turned on when the radiator fan motors are not operating (no voltage is applied to the radiator fan signal relay coil).

When the radiator fan motors are in operation, the same voltage is applied to the relay coil, as a result that the radiator fan signal relay (28) is turned off.

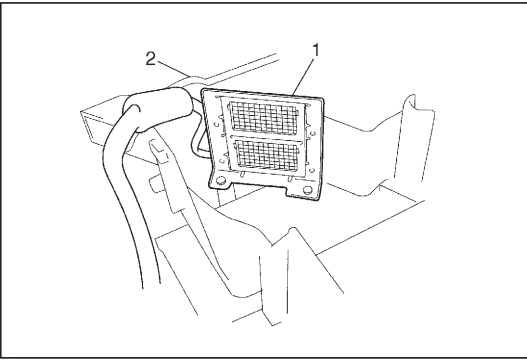

ON-VEHICLE SERVICE

SUPPLEMENTARY HEATER REMOVAL

- 1) Remove heater unit referring to HEATER UNIT REMOVAL in this section.
- 2) Detach clamp to separate heater unit upper and lower cases from each other.
- 3) Remove upper case and remove supplementary heater (1) from lower case (2).

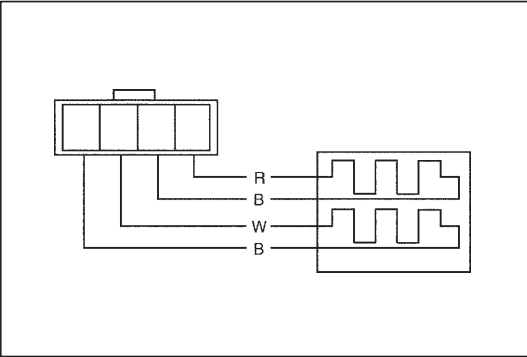

INSPECTION

- Check that there is continuity between heater terminals. If there are no continuity, replace supplementary heater.
- Check heater for crack or any other damage. Replace as necessary.

INSTALLATION

Reverse removal procedure for installation noting the following.

- When installing supplementary ceramic heater, be careful not to keep in contact with wiring harness or other parts.
- Install heater unit referring to HEATER UNIT INSTALLATION in this section.

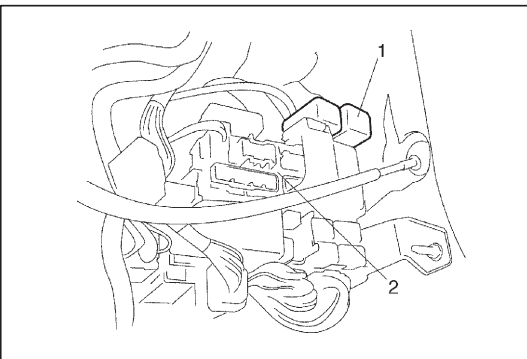

SUPPLEMENTARY HEATER RELAY

INSPECTION

- 1) Disconnect negative (-) cable at battery.
- 2) Remove supplementary ceramic heater relay (1) from junction box (2).

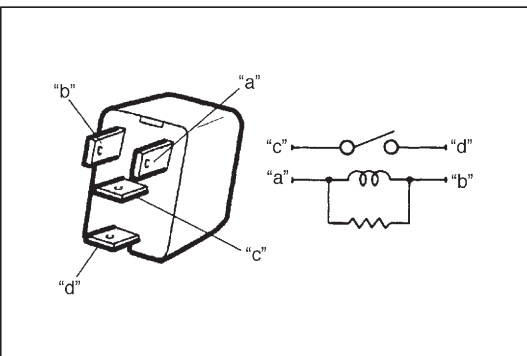

- 3) Check that there is no continuity between terminal "c" and "d". If there is continuity, replace relay.
- 4) Check that there is continuity between terminals "c" and "d" when a 12 V battery is connected to terminals "a" and "b". If malfunction is found, replace it with a new one.

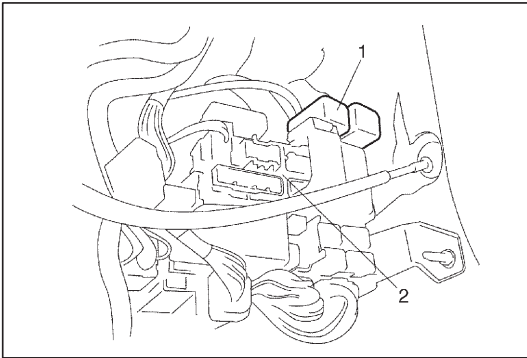

RADIATOR FAN SIGNAL RELAY

INSPECTION

- 1) Disconnect negative (–) cable at battery.
- 2) Remove supplementary ceramic heater relay (1) from junction box (2).

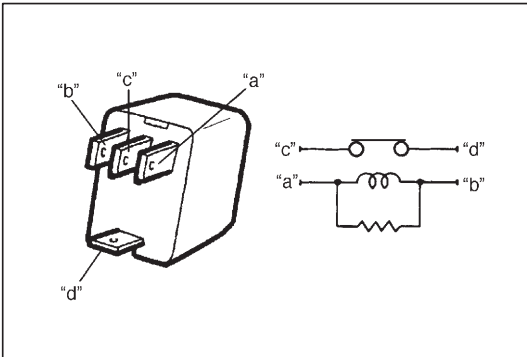

- 3) Check that there is continuity between terminal "c" and "d". If there is no continuity, replace relay.
- 4) Check that there is no continuity between terminal "c" and "d" when a 12 V battery is connected to terminals "a" and "b". If malfunction is found, replace it with a new one.

SUPPLEMENTARY HEATER SWITCH

REMOVAL

- 1) Remove rear console box (1).
- 2) Remove front console box mounting screws (2) and clips (3).
- 3) Disconnect console box wire coupler.
- 4) Remove rear console box.
- 5) Disconnect supplementary heater switch connector.
- 6) Remove supplementary heater switch (5) from console box (4).

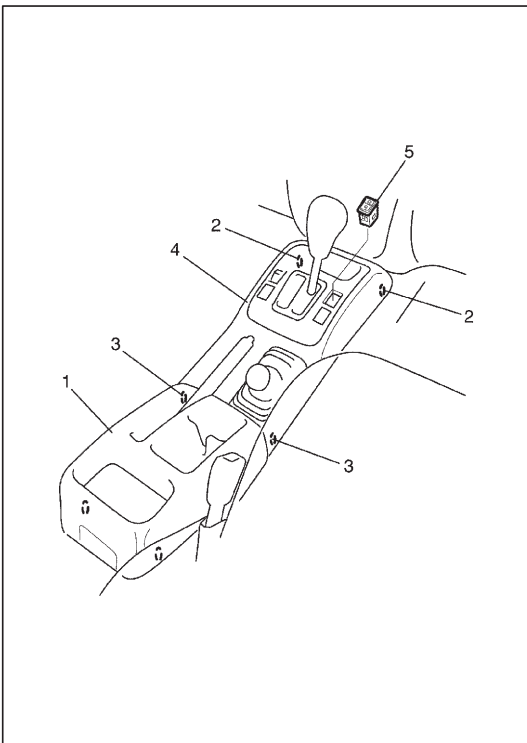

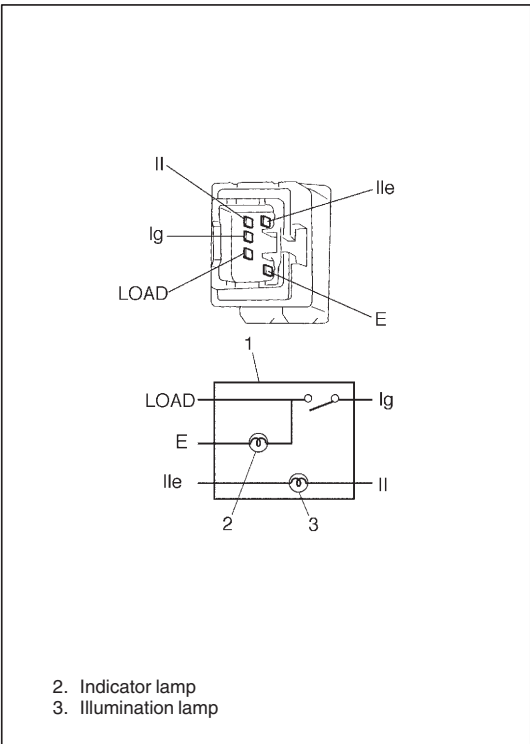

INSPECTION

- Check for switch and lamps by tester.

If there is continuity between terminal as shown in table, supplementary heater switch (1) functions good.

TERMINAL POSITION	Iie	II	E	LOAD	Ig
ON	○—(⊗)—○		○—(⊗)—○	○—(⊗)—○	○
OFF	○—(⊗)—○		○—(⊗)—○		

INSTALLATION

Reverse removal procedure for installation.

SECTION 1B

AIR CONDITIONING (OPTIONAL)

1B

WARNING:

For vehicles equipped with Supplemental Restraint (Air Bag) System:

- Service on and around the air bag system components or wiring must be performed only by an authorized SUZUKI dealer. Refer to “Air Bag System Components and Wiring Location View” under “General Description” in air bag system section in order to confirm whether you are performing service on or near the air bag system components or wiring. Please observe all WARNINGS and “Service Precautions” under “On-Vehicle Service” in air bag system section before performing service on or around the air bag system components or wiring. Failure to follow WARNINGS could result in unintentional activation of the system or could render the system inoperative. Either of these two conditions may result in severe injury.
- Technical service work must be started at least 90 seconds after the ignition switch is turned to the “LOCK” position and the negative cable is disconnected from the battery. Otherwise, the system may be activated by reserve energy in the Sensing and Diagnostic Module (SDM).

CAUTION:

The air conditioning system of this vehicle uses refrigerant HFC-134a (R-134a).

None of refrigerant, compressor oil and component parts is interchangeable between two types of A/C: one using refrigerant CFC-12 (R-12) and the other using refrigerant HFC-134a (R-134a).

Be sure to check which refrigerant is used before any service work including inspection and maintenance. For identification between these two types, refer to the same section of Service Manual mentioned in FOREWORD of this manual.

When replenishing or changing refrigerant and compressor oil and when replacing parts, make sure that the material or the part to be used is appropriate to the A/C installed in the vehicle being serviced. Use of incorrect one will result in leakage of refrigerant, damage in parts or other faulty condition.

NOTE:

- For the descriptions (items) not found in this section, refer to the same section of the Service Manual mentioned in the FOREWORD of this manual.
- For basic servicing method of the air conditioning system that is not described in this section, refer to AIR CONDITIONING BASIC MANUAL (99520-02130).

CONTENTS

GENERAL DESCRIPTION	1B- 2	Compressor Drive Belt	1B-11
Major Components and Location	1B- 2	ON-VEHICLE SERVICE	1B-12
DIAGNOSIS	1B- 3	Relays	1B-12
General	1B- 3	Compressor Assembly	1B-13
Wiring Circuit	1B- 5	REQUIRED SERVICE MATERIAL	1B-14
Inspection of A/C Controller and Its Circuits	1B- 7		

GENERAL DESCRIPTION

MAJOR COMPONENTS AND LOCATION

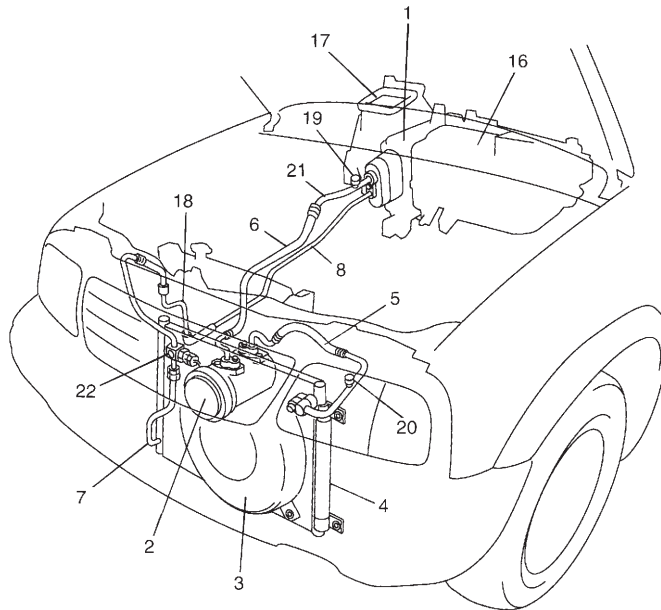
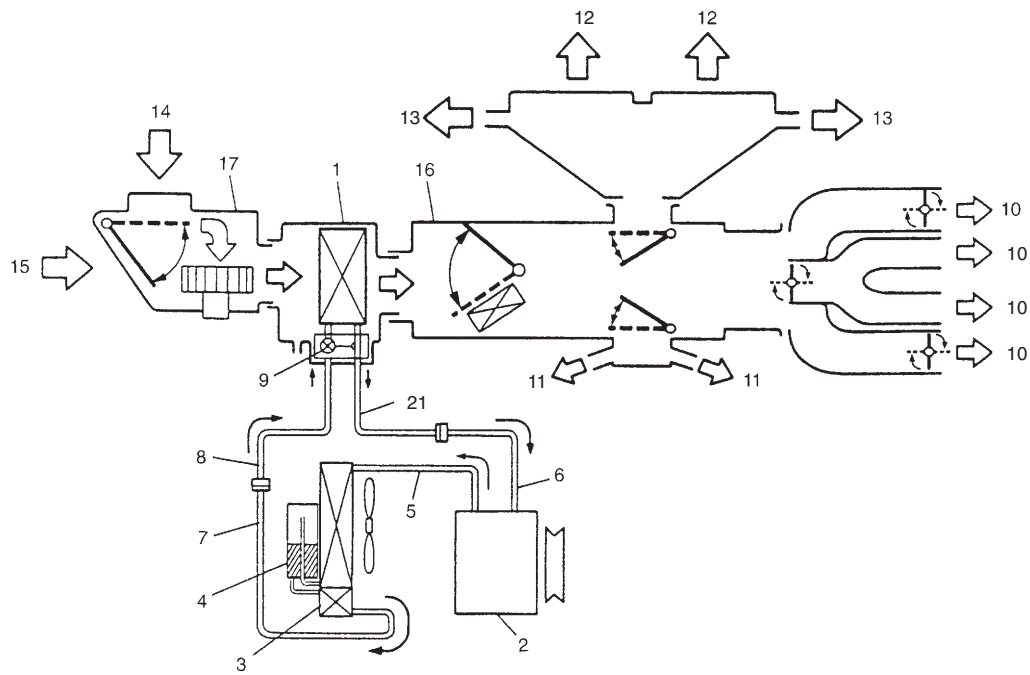

- | | | |
|--------------------------|-----------------------|--|
| 1. Cooling unit | 9. Expansion valve | 17. Air inlet box |
| 2. Compressor | 10. Ventilation air | 18. Dual (Refrigerant) pressure switch |
| 3. Condenser assembly | 11. Foot air | 19. Low pressure charge valve |
| 4. Receiver/dryer | 12. Defroster air | 20. High pressure charge valve |
| 5. Discharge hose | 13. Demister air | 21. Suction pipe |
| 6. Suction hose | 14. Fresh air | 22. Sight glass |
| 7. Condenser outlet pipe | 15. Recirculation air | |
| 8. Liquid pipe | 16. Heater unit | |

DIAGNOSIS

GENERAL

Condition	Possible Cause	Correction
Cool air won't come out (A/C system won't operative)	<ul style="list-style-type: none"> ● No refrigerant ● Fuse blown ● A/C switch faulty ● Blower motor switch faulty ● A/C evaporator thermistor faulty ● Dual pressure switch faulty ● Wiring or grounding faulty ● A/C ON permission signal in ECM faulty ● A/C controller and its circuit faulty 	Recover, evacuation and charging. Check "IG METER", "REAR DEFG", "FRONT BLOW", "25A A/C" fuses, and check for short circuit to ground. Check A/C switch. Check blower motor switch. Check A/C evaporator thermistor. Check dual pressure switch. Repair as necessary. Check ON permission signal. Check A/C controller and its circuit.
Cool air won't come out (A/C compressor won't operative)	<ul style="list-style-type: none"> ● Magnet clutch faulty ● Compressor relay faulty ● Compressor thermal switch faulty ● Compressor drive belt loose or broken ● Compressor faulty ● A/C ON permission signal in ECM faulty ● A/C controller faulty 	Check magnet clutch. Check compressor relay. Check compressor thermal switch. Adjust or replace compressor drive belt. Check compressor. Check ON permission signal. Check A/C controller.
Cool air won't come out (A/C condenser fan motor won't operative)	<ul style="list-style-type: none"> ● Condenser fan motor relay faulty ● Wiring or grounding faulty ● "A/C condenser fan relay" signal in ECM faulty ● Condenser fan motor faulty 	Check condenser cooling fan relay. Repair as necessary. Check A/C condenser fan relay signal. Check condenser fan motor.
Cool air won't come out (Blower motor won't operative)	<ul style="list-style-type: none"> ● Fuse blown ● Blower motor relay faulty ● Blower motor resistor faulty ● Blower motor switch faulty ● Wiring or grounding faulty ● Blower motor faulty 	Check "FRONT BLOW", "REAR DEFG" fuses, and check for short circuit to ground. Check blower motor relay. Check blower motor resistor. Check blower motor switch. Repair as necessary. Check blower motor.
Cool air won't come out or insufficient cooling (A/C system normal operative)	<ul style="list-style-type: none"> ● Insufficient or excessive charge of refrigerant ● Refrigerant leak in system ● Condenser clogged ● A/C evaporator clogged or frosted ● A/C evaporator thermistor faulty ● A/C controller faulty ● Expansion valve faulty ● Compressor drive belt loosen or broken ● Magnetic clutch faulty 	Check charge of refrigerant. Check system for leaks. Check condenser. Check A/C evaporator. Check A/C evaporator thermistor. Check A/C controller. Check expansion valve. Check or replace compressor drive belt. Check magnetic clutch.

Condition	Possible Cause	Correction
Cool air does not come out or insufficient cooling (A/C system normal operative)	<ul style="list-style-type: none"> ● Compressor faulty ● Air in A/C system ● Air leaking from cooling unit or air duct ● Heater and ventilation system faulty ● Blower motor faulty ● Excessive compressor oil existing in A/C system 	<p>Check compressor. Replace condenser dryer, and evacuation and charging. Repair as necessary.</p> <p>Check blower unit. Check heater control lever assembly. Check heater unit. Check blower motor. Pull out compressor oil in A/C system circuit, and replace compressor.</p>
Cool air does not come out only intermittently	<ul style="list-style-type: none"> ● Wiring connection faulty ● Expansion valve faulty ● Excessive moisture in A/C system ● A/C controller faulty ● Magnetic clutch faulty ● Excessive charge of refrigerant 	<p>Repair as necessary. Check expansion valve. Replace condenser dryer, and evacuation and charging. Check A/C controller. Check magnetic clutch. Check charge of refrigerant.</p>
Cool air comes out only at high speed	<ul style="list-style-type: none"> ● Condenser clogged ● Insufficient charge of refrigerant ● Air in A/C system ● Compressor drive belt loosen or broken ● Compressor faulty 	<p>Check condenser. Check charge of refrigerant. Replace condenser dryer, and evacuation and charging. Adjust or replace compressor drive belt.</p> <p>Check compressor.</p>
Cool air does not come out only at high speed	<ul style="list-style-type: none"> ● Excessive charge of refrigerant ● A/C evaporator frosted 	<p>Check charge refrigerant. Check A/C evaporator. Check A/C evaporator thermistor.</p>
Insufficient velocity of cooled air	<ul style="list-style-type: none"> ● A/C evaporator clogged or frosted ● Air leaking from cooling unit or air duct ● Blower motor faulty ● Wiring or grounding faulty 	<p>Check A/C evaporator. Repair as necessary.</p> <p>Check blower motor. Repair as necessary.</p>

WIRING CIRCUIT

For LH model

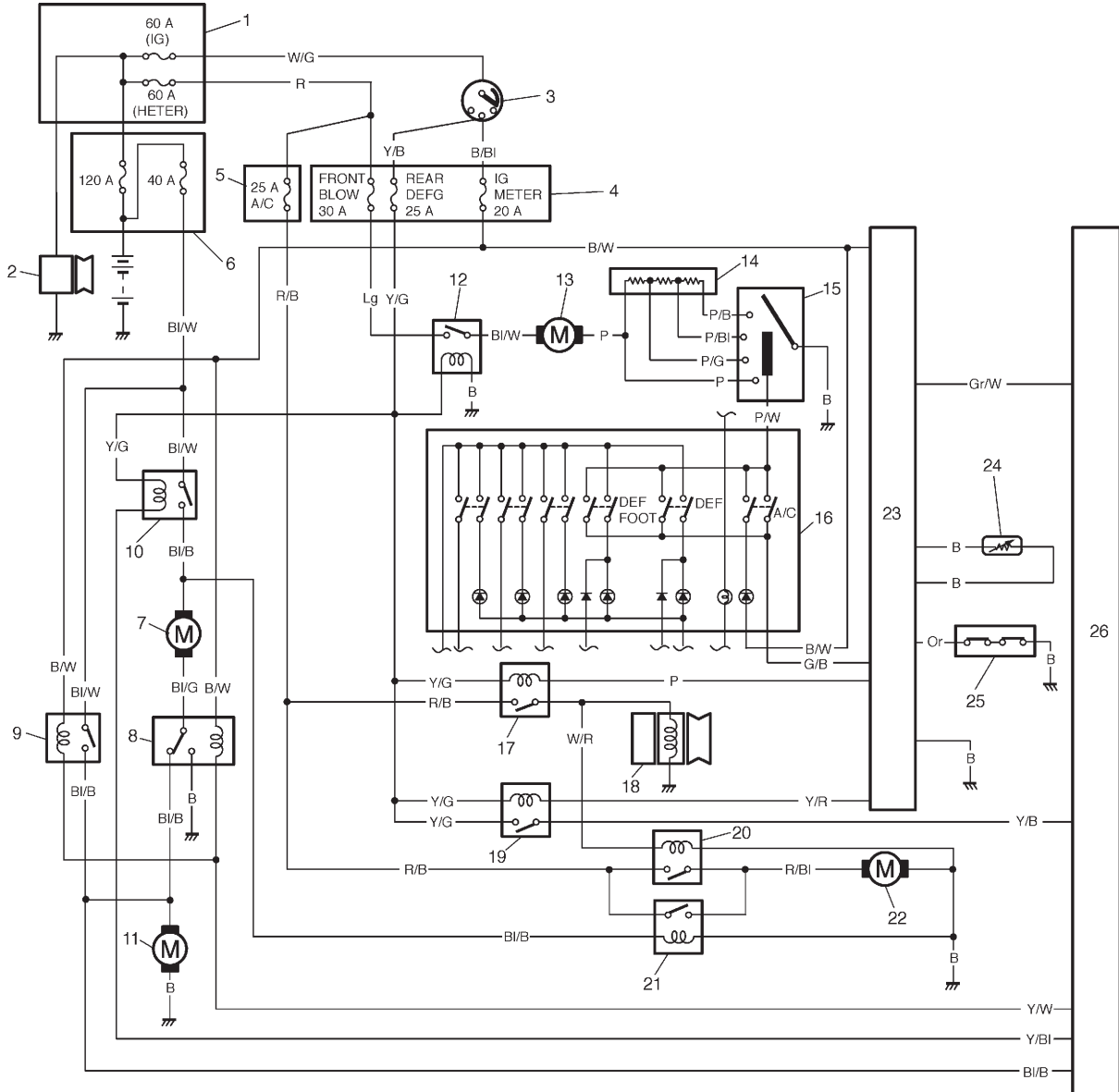

- | | | |
|---|------------------------------------|--|
| 1. Main fuse box | 10. Radiator fan relay 3 (low) | 19. A/C signal relay |
| 2. Generator | 11. Radiator fan motor No.2 | 20. Condenser fan motor relay |
| 3. Ignition switch | 12. Blower motor relay | 21. Condenser fan motor control relay |
| 4. Circuit fuse box | 13. Blower motor | 22. Condenser fan motor |
| 5. Cassette fuse
(compressor and condenser fan motor fuse) | 14. Blower motor resistor | 23. A/C controller |
| 6. Cassette fuse (radiator fan motor and battery fuses) | 15. Blower motor switch | 24. A/C evaporator thermistor |
| 7. Radiator fan motor No.1 | 16. A/C switch and mode controller | 25. Dual (Refrigerant) pressure sensor |
| 8. Radiator fan relay 1 (high) | 17. Compressor relay | 26. ECM |
| 9. Radiator fan relay 2 (high) | 18. Compressor | |

For RH model

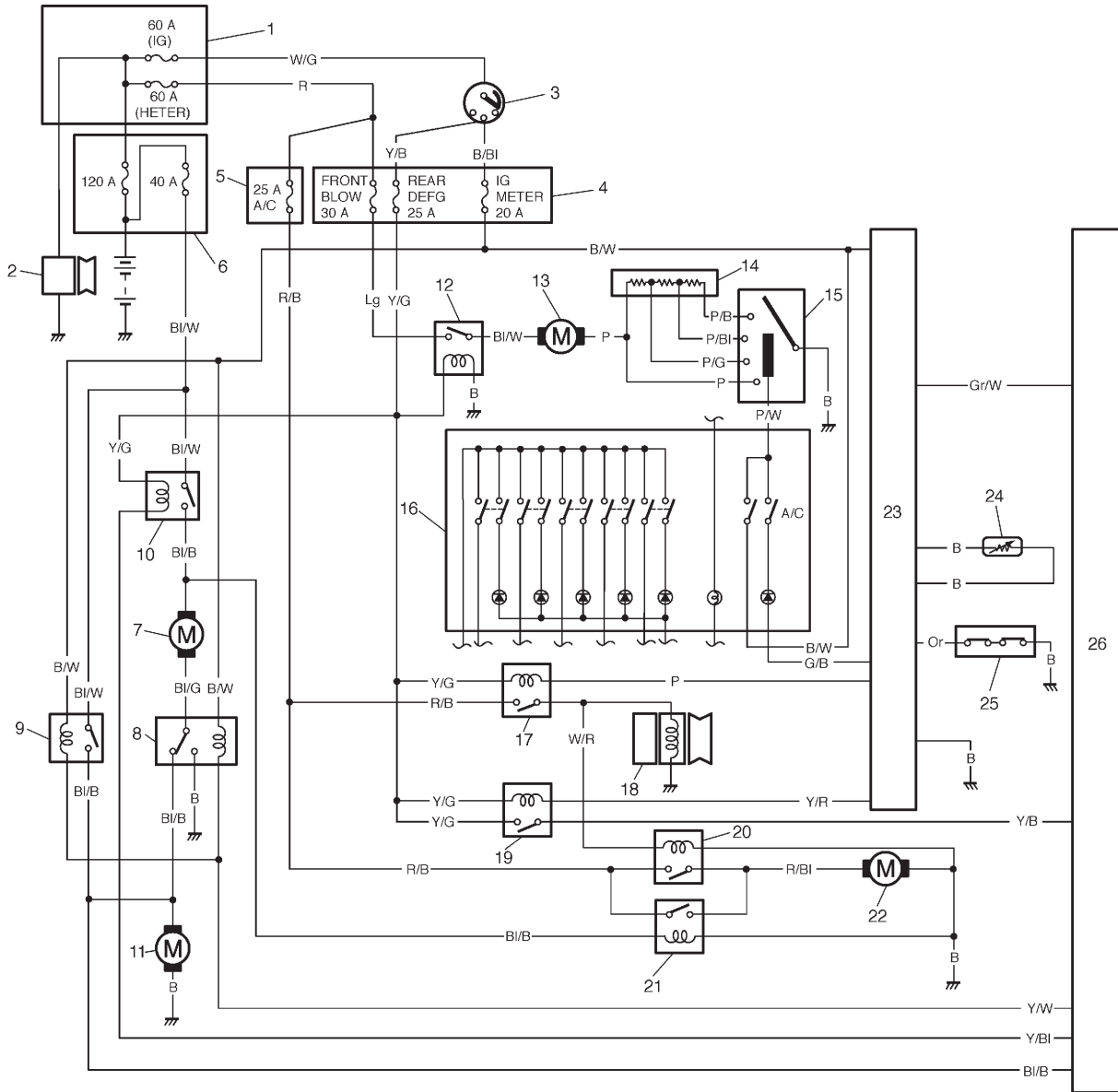

- | | | |
|---|------------------------------------|--|
| 1. Main fuse box | 10. Radiator fan relay 3 (low) | 19. A/C signal relay |
| 2. Generator | 11. Radiator fan motor No.2 | 20. Condenser fan motor relay |
| 3. Ignition switch | 12. Blower motor relay | 21. Condenser fan motor control relay |
| 4. Circuit fuse box | 13. Blower motor | 22. Condenser fan motor |
| 5. Cassette fuse
(Compressor and condenser fan motor fuse) | 14. Blower motor resistor | 23. A/C controller |
| 6. Cassette fuse (radiator fan motor and battery fuses) | 15. Blower motor switch | 24. A/C evaporator thermistor
(A/C evaporator temperature sensor) |
| 7. Radiator fan motor No.1 | 16. A/C switch and mode controller | 25. Dual (Refrigerant) pressure sensor |
| 8. Radiator fan relay 1 (high) | 17. Compressor relay | 26. ECM |
| 9. Radiator fan relay 2 (high) | 18. Compressor | |

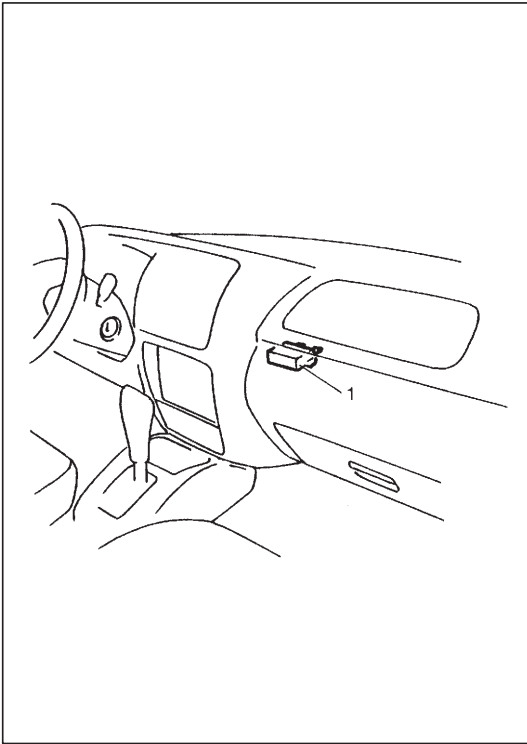

INSPECTION OF A/C CONTROLLER AND ITS CIRCUITS

CAUTION:

A/C controller and ECM cannot be checked by itself. It is strictly prohibited to connect voltmeter or ohmmeter to A/C controller and ECM with couplers disconnected from it.

A/C system can be checked at A/C controller (1) and ECM wiring couplers by measuring voltage.

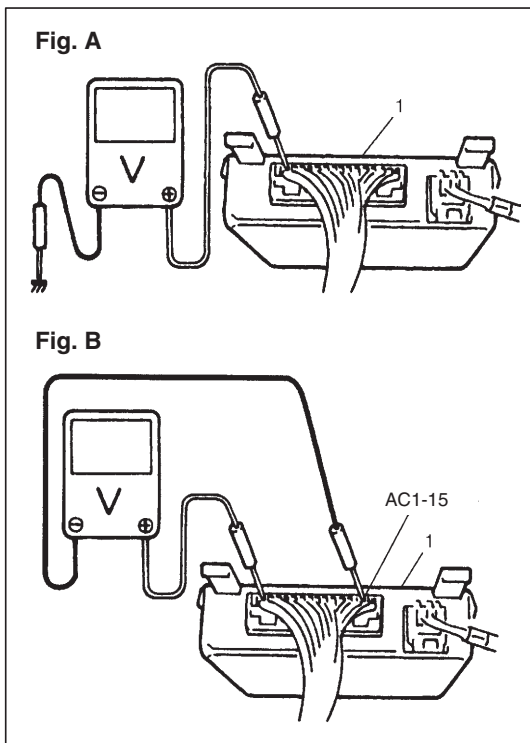

Voltage Check

NOTE:

For ECM terminal voltage check, refer to “INSPECTION OF ECM (PCM) AND ITS CIRCUITS” in Section 6.

- 1) Remove A/C controller (1) from vehicle by referring to “REMOVAL” under “A/C CONTROLLER” in this section.
- 2) Connect A/C controller couplers to A/C controller (1).
- 3) Check each terminal voltage with couplers connected by referring to after-mentioned “A/C CONTROLLER VOLTAGE VALUES TABLE” and “ECM VOLTAGE VALUES TABLE”.

SYSTEM CIRCUIT

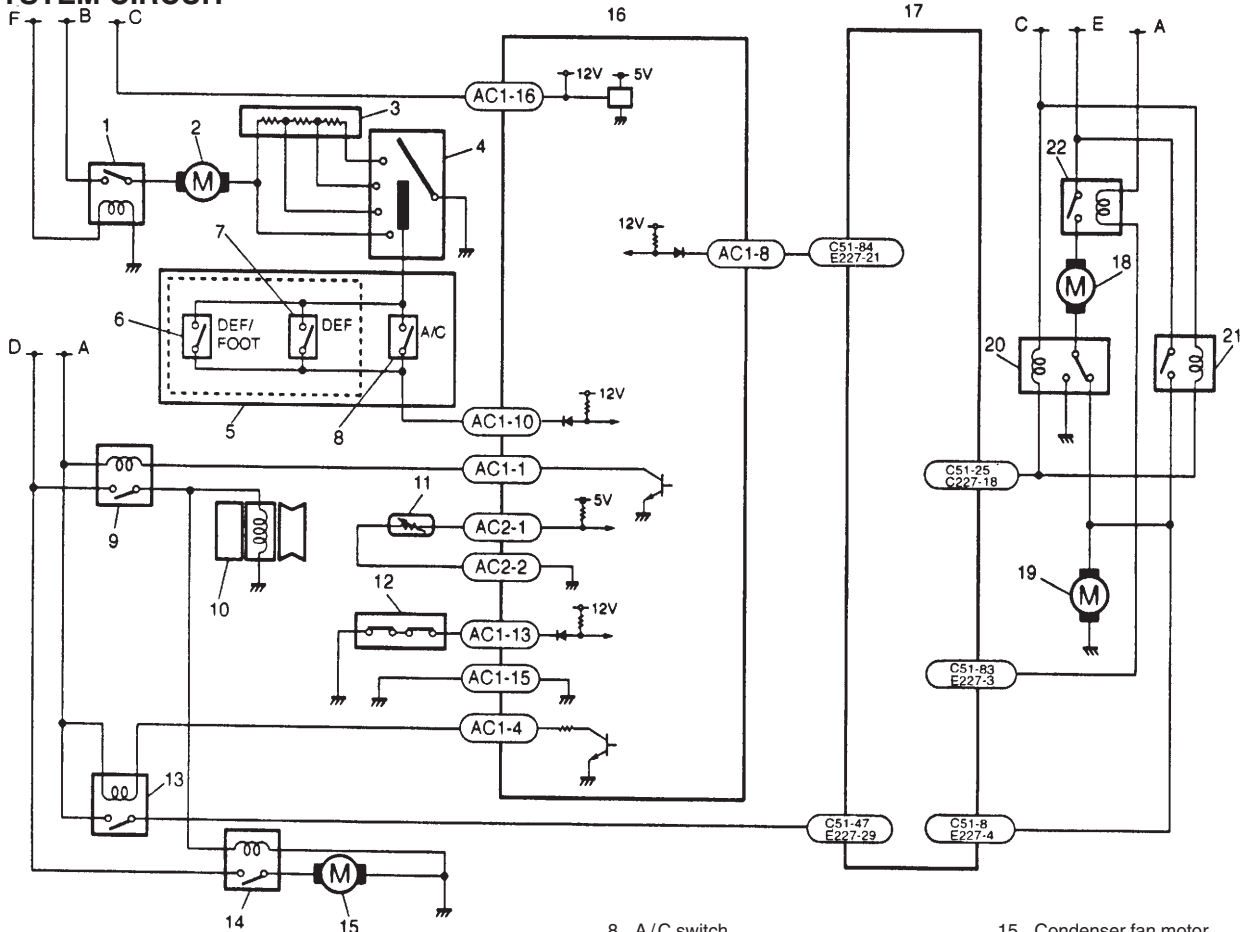

- | | | | |
|---------------------------|------------------------------------|--|---------------------------------|
| A. To double relay | 1. Blower motor relay | 8. A/C switch | 15. Condenser fan motor |
| B. To "FRONT BLOW" fuse | 2. Blower motor | 9. Compressor relay | 16. A/C controller |
| C. To "IG METER" fuse | 3. Blower motor resistor | 10. Compressor | 17. ECM |
| D. To "25A A/C" fuse | 4. Blower motor switch | 11. A/C evaporator thermistor | 18. Radiator fan motor No.1 |
| E. To "40A" cassette fuse | 5. A/C switch and mode controller | (A/C evaporator temperature sensor) | 19. Radiator fan motor No.2 |
| F. To "REAR DEFG" fuse | 6. Defroster position switch | 12. Dual (Refrigerant) pressure switch | 20. Radiator fan relay 1 (high) |
| | 7. Defroster/ Foot position switch | 13. A/C signal relay | 21. Radiator fan relay 2 (high) |
| | (LH model only) | 14. Condenser fan motor relay | 22. Radiator fan relay 3 (low) |
| | (LH model only) | | |

TERMINAL ARRANGEMENT OF A/C CONTROLLER (VIEWED FROM HARNESS SIDE)

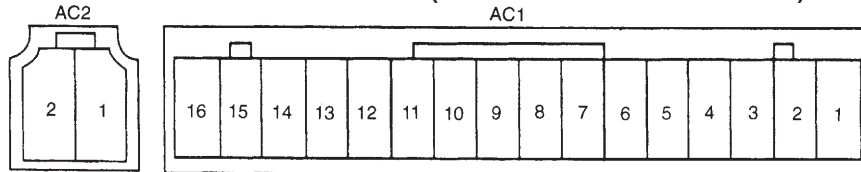

TERMINAL ARRANGEMENT OF ECM (VIEWED FROM HARNESS SIDE)

For single-connector ECM

C51

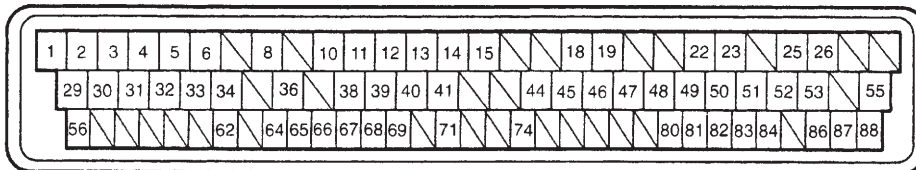

For triple-connector ECM

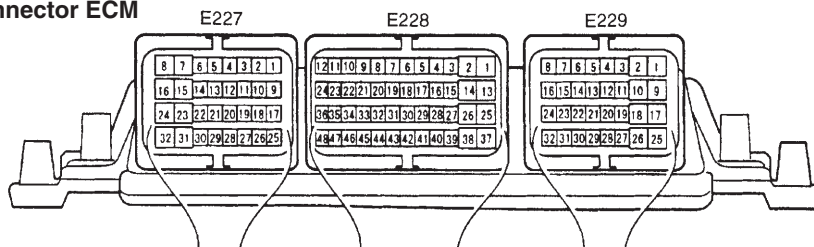

A/C CONTROLLER VOLTAGE VALUES TABLE

Terminal	Wire color	Circuit	Measurement ground	Normal value	Condition
AC1-1	P	Compressor magnet Clutch relay drive	Ground to engine (Fig. B)	-0.3 – 0.3 V	Fulfill all the following conditions <ul style="list-style-type: none"> ●Blower fan motor switch ON ●Fulfill either the following conditions <ul style="list-style-type: none"> – A/C switch ON – Defroster position or defroster/foot position switch ON (LH model only) ●Engine running ●A/C evaporator temperature sensor temperature input more than approx. 4°C (39.2°F) ●Dual (Refrigerant) pressure switch ON ●Signal input from ECM ON
				12 – 15 V	Except the above-mentioned conditions with engine running
AC1-4	Y/R	A/C ON signal output to A/C controller through relay	Ground to engine (Fig. B)	4 – 6 V	Fulfill all the following conditions <ul style="list-style-type: none"> ●Blower fan motor switch ON ●Fulfill either the following conditions <ul style="list-style-type: none"> – A/C switch ON – Defroster position or defroster/foot position switch ON (LH model only) ●Engine running ●A/C evaporator temperature sensor temperature input more than approx. 4°C (39.2°F) ●Dual (Refrigerant) pressure switch ON
				12 – 15 V	Except the above-mentioned conditions with engine running
AC1-8	Gr/W	A/C ON permission	Ground to engine (Fig. B)	10 – 14 V	Approve of A/C ON
				-0.3 – 0.3 V	A/C ON forbid
AC1-10	G/B	A/C switch and/or defroster switch ON signal input	Ground to engine (Fig. B)	-0.3 – 0.3 V	Fulfill all the following conditions <ul style="list-style-type: none"> ●Blower fan motor switch ON ●Fulfill either the following conditions <ul style="list-style-type: none"> – A/C switch ON – Defroster position or defroster/foot position switch ON (LH model only) ●Engine running
				12 – 15 V	Except the above-mentioned condition with engine running
AC1-13	Or	Dual (Refrigerant) pressure switch input	Ground to engine (Fig. B)	-0.3 – 0.3 V	Dual (Refrigerant) pressure is ON with engine running. For detail, refer to “DUAL PRESSURE SWITCH” in this section
				12 – 15 V	Dual (Refrigerant) pressure is OFF with engine running. For detail, refer to “DUAL PRESSURE SWITCH” in this section
AC1-15	B	Controller main ground	Ground to body (Fig. A)	-0.3 – 0.3 V	Engine running
AC1-16	B/W	Controller main power supply	Ground to engine (Fig. B)	10 – 14 V	Ignition switch is ON position
AC2-1	B	A/C evaporator temperature sensor (A/C evaporator thermistor) input	Ground to engine (Fig. B)	Approx. 1.0 V (Approx. 2215 Ω)	A/C evaporator temperature sensor temperature at approx. 25°C (77°F) with engine running
				Approx. 2.0 V (Approx. 5995 Ω)	A/C evaporator temperature sensor temperature at approx. 4°C (39.2°F) with engine running If the temperature is less than approx. 4°C (39.2°F), in this case compressor and condenser fan should be stop, and come back at more than approx. 6°C (42.8°F)
AC2-2	B	Sensor ground	Ground to body (Fig. A)	-0.3 – 0.3 V	Engine running

ECM VOLTAGE VALUES TABLE

Terminal	Wire	Circuit	Measurement ground	Normal value	Condition
C51-8 E227-4	Bl/B	Radiator fan motor state input	ECM ground terminal	-0.3 – 0.3 V	Radiator fan state OFF with engine running
				4 – 5 V	Radiator fan state low with engine running
				12 – 15 V	Radiator fan state high with engine running
C51-25 E227-18	Y/W	Radiator fan motor relay drive output (high)	ECM ground terminal	-0.3 – 0.3 V	Engine coolant temperature sensor more than 105°C (221°F) with engine running, in this case relay should be drive, and it come back at less than 101°C (213.8°F)
				12 – 15 V	Except the above-mentioned condition with engine running
C51-47 E227-29	Y/B	A/C ON signal input from A/C controller	ECM ground terminal	12 – 15 V	A/C ON
				-0.3 – 0.3 V	A/C OFF
C51-83 E227-3	Y/Bl	Radiator fan motor relay drive (low)	ECM ground terminal	-0.3 – 0.3 V	A/C ON signal input from A/C controller through relay Engine coolant temperature at more than 97°C (206.6°F) with engine running, in this case relay should be drive and it come back at less than 93°C (199.4°F)
				12 – 15 V	Except the above-mentioned conditions with engine running
C51-84 E227-21	Gr/W	A/C ON permission signal to A/C controller	ECM ground terminal	12 – 15 V	A/C ON at engine running with normal condition
				-0.3 – 0.3 V	ECT sensor temperature more than 110°C (230°F), in this case ECM is not permission A/C signal and it come back at less than approx. 108.5°C (227.3°F)

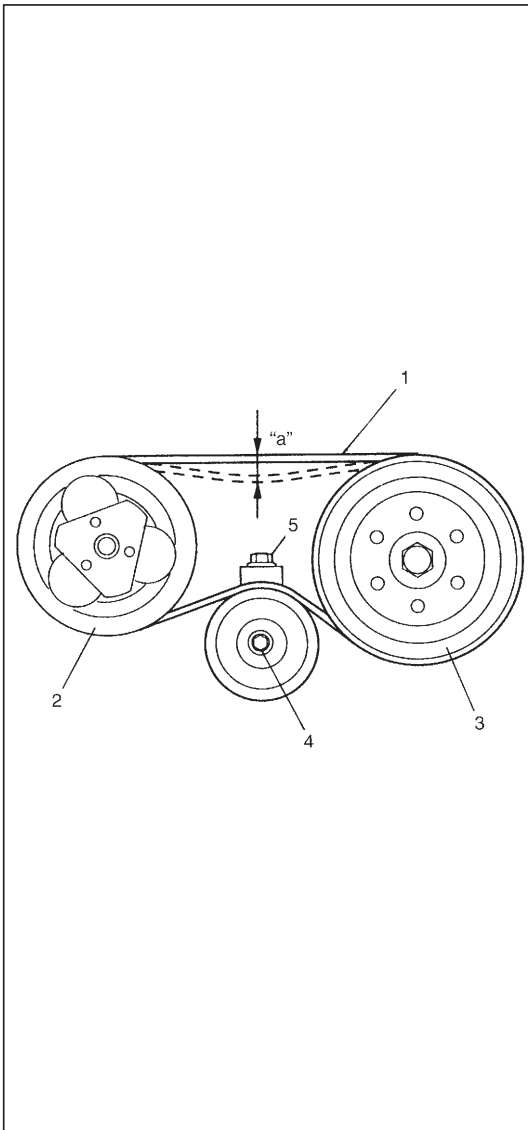

COMPRESSOR DRIVE BELT

INSPECTION

- Check compressor drive belt (1) for wear and cracks, and replace as necessary.
- Check compressor drive belt (1) tension by measuring how much it deflects when pushed at intermediate point between compressor pulley (2) and crank shaft additional pulley (3) with about 100 N (10 kg) force after crankshaft additional pulley 1 rotating. If belt tension is without specification, adjust belt tension referring to below procedures.

Compressor drive belt tension

“a”: 9 mm (0.35 in.)

ADJUSTMENT

- 1) Loosen tension pulley nut (4).
- 2) Adjust belt tension by tighten or loosen tension pulley adjusting bolt (5).
- 3) Tighten tension pulley nut (4).
- 4) Turn the crankshaft additional pulley (3) 1 revolution, then check belt tension.

REPLACEMENT

- 1) Loosen tension pulley nut (4).
- 2) Loosen belt tension by loosen tension pulley adjusting bolt (5).
- 3) Remove compressor drive belt (1).
- 4) Install new compressor drive belt.
- 5) Adjust belt tension referring to above procedure.

ON-VEHICLE SERVICE

RELAYS

NOTE:

Refer to "RADIATOR FAN CONTROL SYSTEM" in Section 6E3 for radiator fan relay 1, radiator fan relay 2 and radiator fan relay 3.

INSPECTION

- 1) Disconnect negative (-) cable at battery.
- 2) Remove condenser cooling fan motor relay (1), compressor relay (2), condenser cooling fan control relay (4) and/or A/C signal relay (5) from vehicle.
- 3) Check that there is no continuity between terminal "c" and "d". If there is continuity, replace relay.
- 4) Connect battery positive (+) terminal to terminal "b" of relay. Connect battery negative (-) terminal "a" of relay. Check continuity between terminal "c" and "d". If there is no continuity when relay is connected to the battery, replace relay.

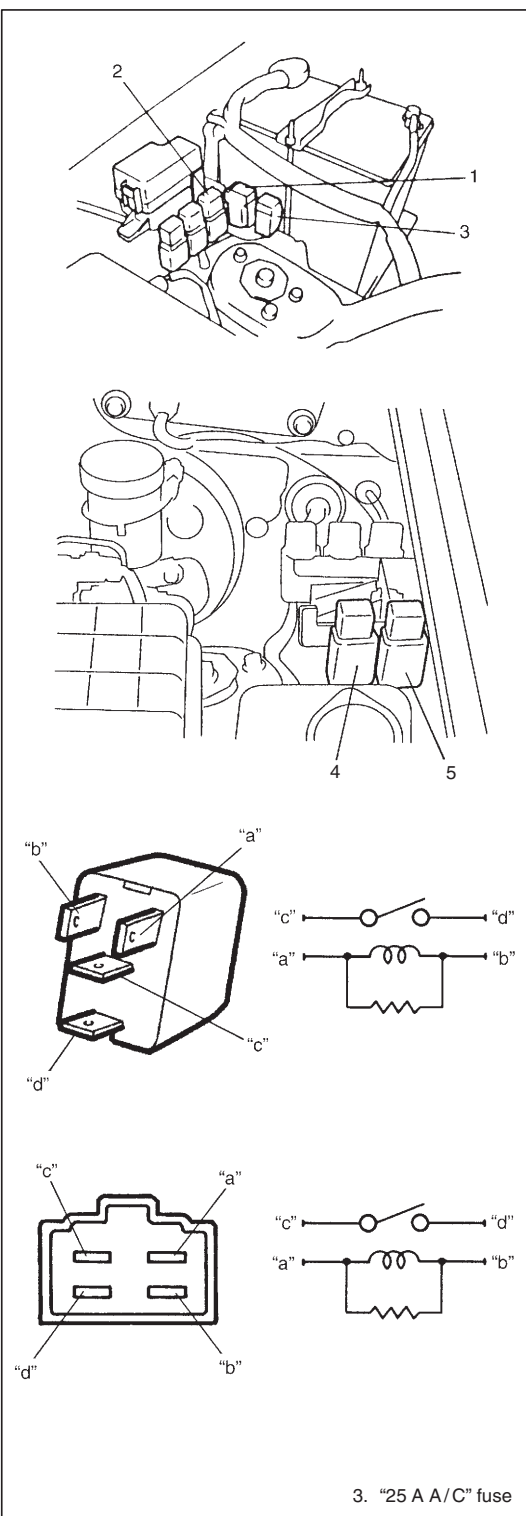

COMPRESSOR ASSEMBLY

REMOVAL

- 1) Run engine at idle with A/C ON for 10 minutes.
- 2) Disconnect negative (-) cable at battery.

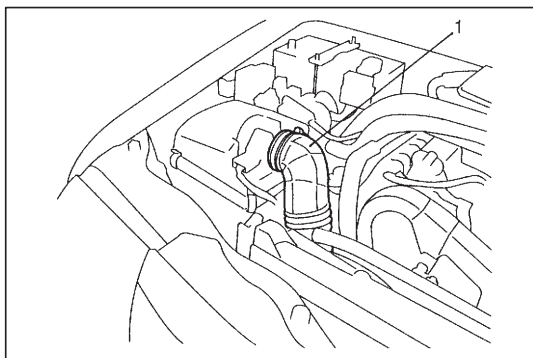

- 3) Remove air cleaner outlet hose (1).
- 4) Recover refrigerant from refrigeration system using recovery and recycling equipment.

NOTE:

The amount of compressor oil at removed must be measured and the same amount must be poured when installing the compressor.

- 5) Disconnect thermal protector lead wire.

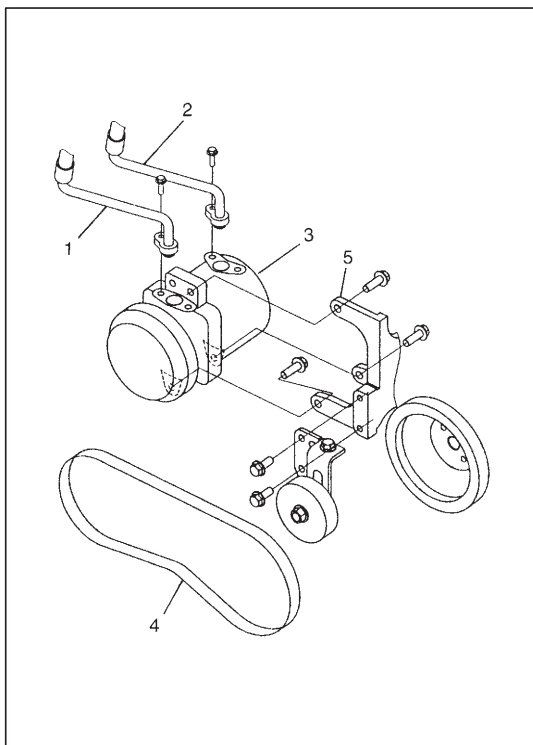

- 6) Disconnect suction hose (1) and discharge hose (2) from compressor (3).

NOTE:

Cap open fitting immediately to keep moisture out of system.

- 7) Remove compressor drive belt (4) referring to "DRIVE BELT" in this section.
- 8) Remove compressor (3) from engine mounting (5).
- 9) If compressor (3) is replaced. Drain oil from compressor (3) and measure its amount.

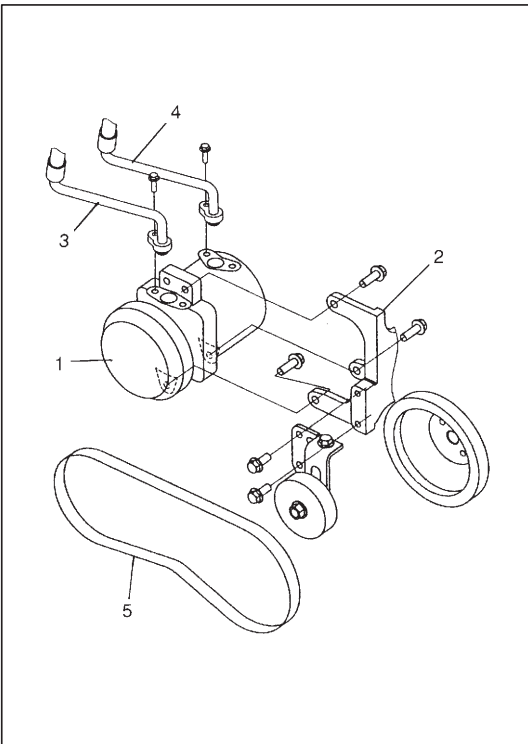

INSTALLATION

1) Pour new compressor oil. The amount must be the same with the amount measured in "REMOVAL".

NOTE:

Compressor supplied from factory is filled up with the following amount of oil.

Amount of oil in compressor: 120 cm³ (120 cc)

- 2) Install compressor (1) to engine bracket (2).
- 3) Connect suction hose (3) and discharge hose (4) to compressor (1).
- 4) Install compressor drive belt (5) referring to "DRIVE BELT" in this section.
- 5) Connect thermal protector lead wire.
- 6) Install air cleaner outlet hose.
- 7) Perform evacuation and charging referring to "REFRIGERANT RECOVERY, EVACUATION AND CHARGING" in this section.

REQUIRED SERVICE MATERIAL

MATERIAL	RECOMMENDED SUZUKI PRODUCT	USE
Compressor oil	COMPRESSOR OIL RS20 (150 cc) 99000-99088-00D0	<ul style="list-style-type: none"> ● O-ring ● Each component

SECTION 3B1

POWER STEERING (P/S) SYSTEM

WARNING:

For vehicles equipped with Supplemental Restraint (Air Bag) System:

- Service on and around the air bag system components or wiring must be performed only by an authorized SUZUKI dealer. Refer to “Air Bag System Components and Wiring Location View” under “General Description” in air bag system section in order to confirm whether you are performing service on or near the air bag system components or wiring. Please observe all WARNINGS and “Service Precautions” under “On-Vehicle Service” in air bag system section before performing service on or around the air bag system components or wiring. Failure to follow WARNINGS could result in unintentional activation of the system or could render the system inoperative. Either of these two conditions may result in severe injury.
- Technical service work must be started at least 90 seconds after the ignition switch is turned to the “LOCK” position and the negative cable is disconnected from the battery. Otherwise, the system may be activated by reserve energy in the Sensing and Diagnostic Module (SDM).

3B1

NOTE:

- For the descriptions (items) not found in this section, refer to the same section of the Service Manual mentioned in FOREWORD of this manual.
- Some parts in the Power Steering Gear Box cannot be disassembled or adjusted. For detailed information, refer to the description of POWER STEERING GEAR BOX COMPONENTS under REMOVE AND INSTALL POWER STEERING GEAR BOX.
- All steering gear fasteners are important attaching parts in that they could affect the performance of vital parts and systems, and/or could result in major repair expense. They must be replaced with one of the same part number or with an equivalent part if replacement becomes necessary. Do not use a replacement part of lesser quality or substitute design. Torque values must be used as specified during reassembly to assure proper retention of these parts.

CONTENTS

GENERAL DESCRIPTION	3B1-2
Power Steering (P/S) Pump Assembly	3B1-2
DIAGNOSIS	3B1-2
Power Steering Pump Drive Belt	3B1-2
Fluid Leakage Check	3B1-2
Hydraulic Pressure in P/S Circuit Check	3B1-3
ON-VEHICLE SERVICE	3B1-5
Power Steering Pump	3B1-5
TIGHTENING TORQUE SPECIFICATIONS	3B1-7
REQUIRED SERVICE MATERIALS	3B1-7
SPECIAL TOOLS	3B1-7

GENERAL DESCRIPTION

POWER STEERING (P/S) PUMP ASSEMBLY

Power steering (P/S) pump specification:

The specification of this P/S pump assembly is the same as the specification of the same section in the service manual mentioned in this manual except for data of relieved pressure shown below.

Relieved pressure:

7850 kPa (78.5 kg/cm², 1116 psi)

DIAGNOSIS

POWER STEERING PUMP DRIVE BELT

INSPECTION

For the details, refer to INSPECTION of GENERATOR BELT in Section 6H.

FLUID LEAKAGE CHECK

Start engine and turn steering wheel fully to the right and left so that maximum hydraulic pressure is provided. Then visually check gear box, P/S pump and P/S fluid reservoir themselves and each joint of their connecting pipes for leakage.

CAUTION:

Never keep steering wheel turned fully for longer than 10 seconds.

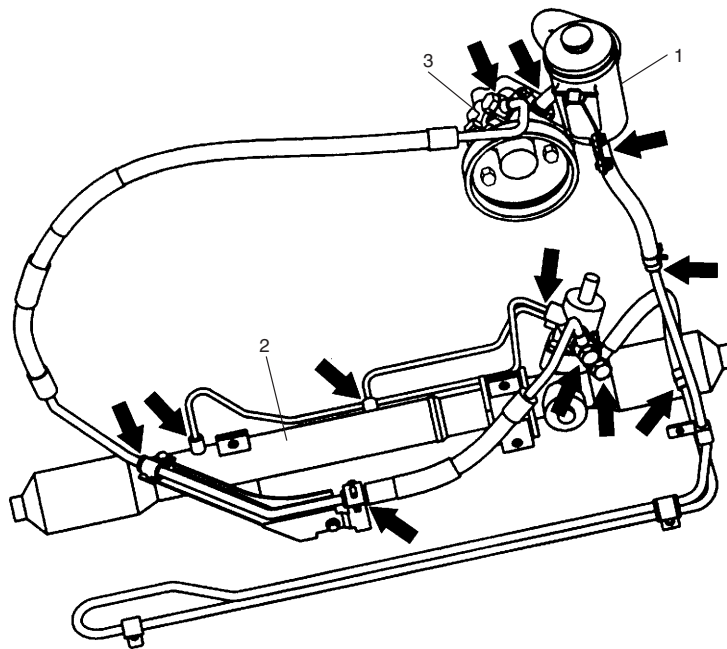

1. P/S fluid reservoir
2. Gear box
3. P/S pump

HYDRAULIC PRESSURE IN P/S CIRCUIT CHECK

- 1) After cleaning joint of high pressure hose and P/S pump thoroughly, disconnect hose from pump and install special tool (oil pressure gauge, attachment and hose). Tighten each flare nut to specified torque.

CAUTION:

Take care not to cause damage to A/C condenser during service operation, if equipped.

Special Tool

(A): 09915-77410 (Oil pressure gauge)

(B): 09915-77420

- 2) Check each connection for fluid leakage and bleed air. (Refer to AIR BLEEDING PROCEDURE.)

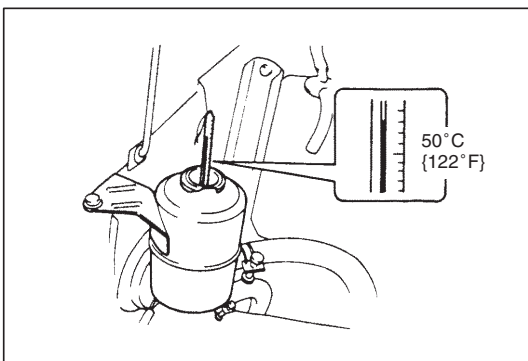
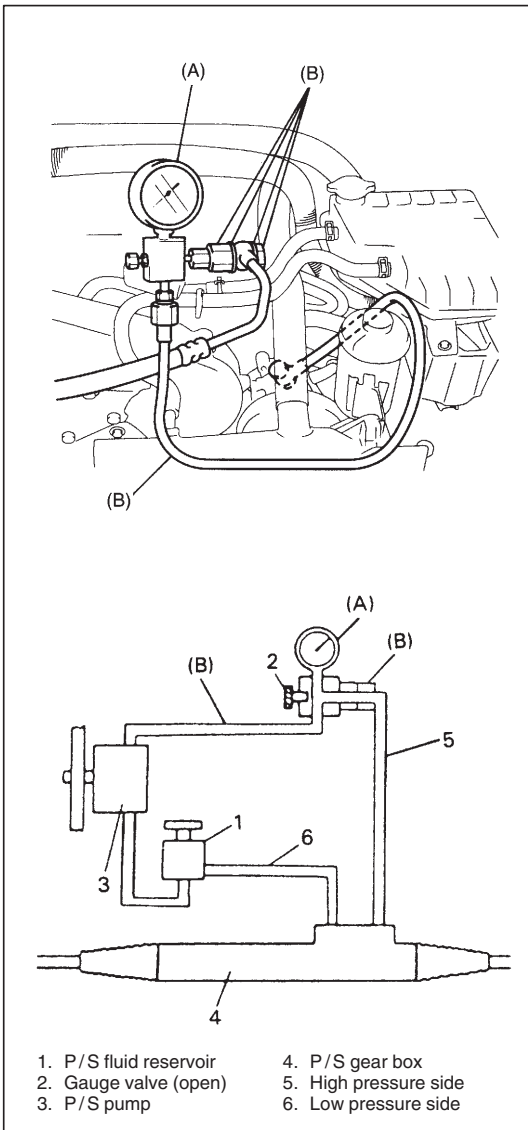

- 3) With engine idling, turn steering wheel and warm up engine till temperature of fluid in P/S fluid reservoir rises to 50 – 60°C (122 – 140°F).

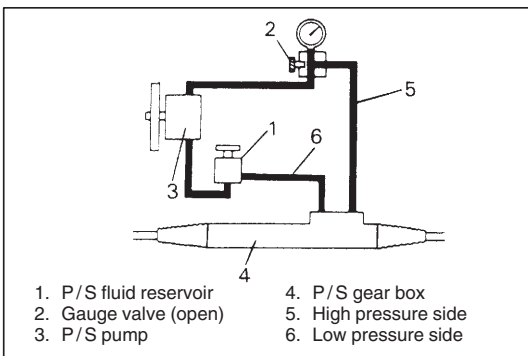

- 4) Check line pressure by measuring hydraulic pressure with engine idling and hands off steering wheel.

Line pressure: Lower than 1000 kPa (10 kg/cm², 142 psi)

When line pressure is higher than specified values, check control valve and piping for clogging.

5) Check relief pressure

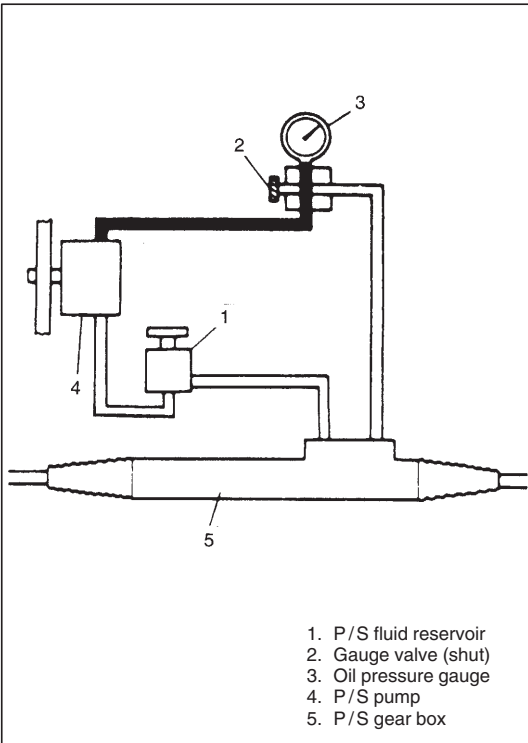

a) Increase engine speed to about 1,500 r/min (rpm). Close gauge valve gradually while watching pressure increase indicated by gauge and take reading of relief pressure (maximum hydraulic pressure).

Relief pressure:

7650 – 8350 kPa (76.5 – 83.5 kg/cm², 1088 – 1187 psi)

- When it is higher than specified values, possible cause is malfunction of relief valve.
- When it is lower than specified values, possible cause is either failure of P/S pump or settling of relief valve spring.

CAUTION:

Be sure not to close gauge valve for longer than 10 seconds.

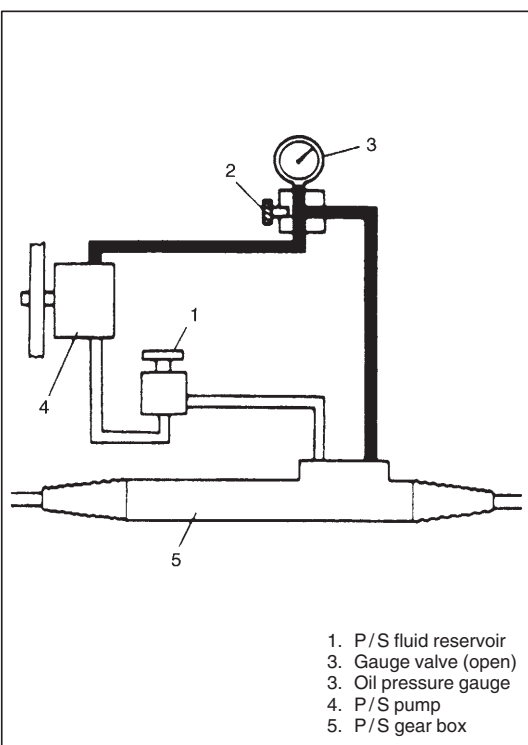

b) Next, open gauge valve fully and increase engine speed to about 1,500 r/min (rpm). Then turn steering wheel to the left or right fully and take reading of relief pressure.

Relief pressure:

7650 – 8350 kPa (76.5 – 83.5 kg/cm², 1088 – 1187 psi)

- When it is higher than specified values, possible cause is malfunction of relief valve.
- When it is lower than specified values, possible cause is failure in steering gear box. Replace gear box.

CAUTION:

Be sure not to hold steering wheel at fully turned position for longer than 10 seconds.

ON-VEHICLE SERVICE

POWER STEERING PUMP

[LH]

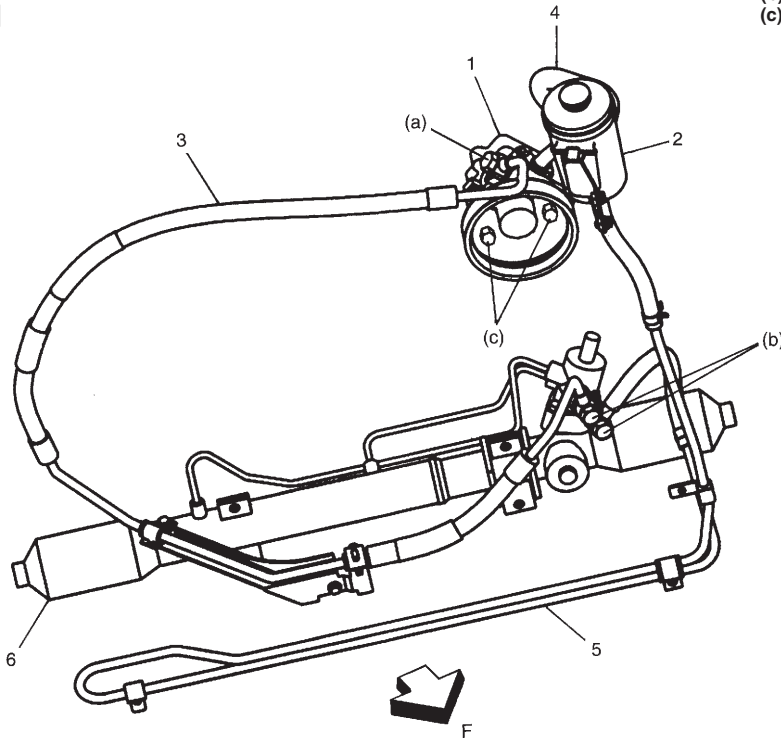

Tightening Torque
(a): 60 N·m (6.0 kg·m, 43.5 lb-ft)
(b): 35 N·m (3.5 kg·m, 25.5 lb-ft)
(c): 25 N·m (2.5 kg·m, 18.5 lb-ft)

[RH]

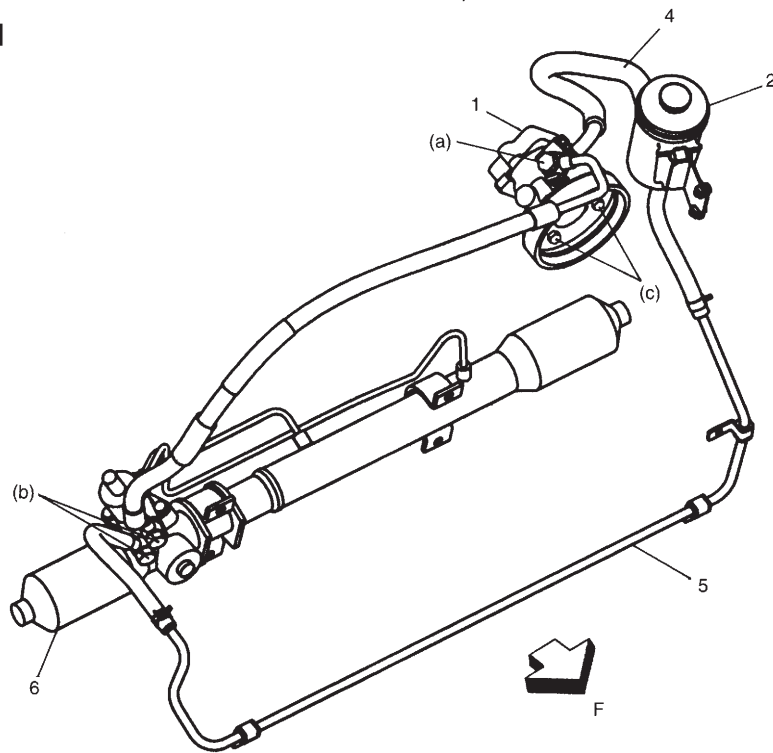

- 1. Power steering pump assembly
- 2. P/S fluid reservoir
- 3. High pressure hose & pipe
- 4. Suction pipe
- 5. Low pressure return pipe
- 6. Steering gear case

[LH]: For left hand steering vehicle
[RH]: For right hand steering vehicle
F : Forward

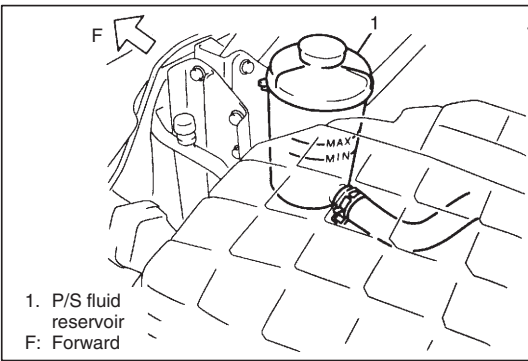

REMOVAL

NOTE:

Be sure to clean each joint of suction and discharge sides thoroughly before removal.

- 1) Remove suction hose from pump, then disconnect battery negative cable.
- 2) Remove P/S fluid reservoir with suction hose.

- 3) Remove union bolt. Then disconnect high pressure pipe from pump.

NOTE:

As fluid flows out of disconnected joints, put a receptacle under joints or a plug to pipe.

- 4) Loosen related bolts and remove power steering drive belt.

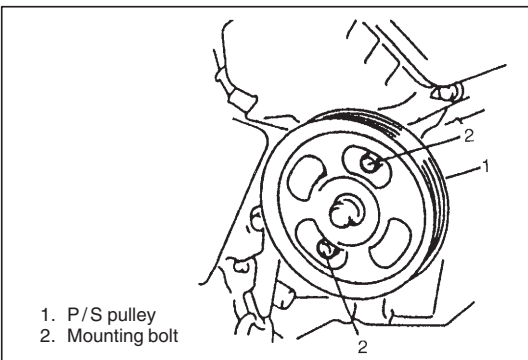

- 5) Remove P/S pump mounting bolt (s).
- 6) Remove P/S pump.

NOTE:

Plug each port of removed pump to prevent dust or any other foreign matter from entering.

DISASSEMBLY AND ASSEMBLY

For the disassembly and assembly procedures of P/S pump, refer to the same section of the service manual mentioned in FOREWORD of this manual, excluding the description of pressure switch (terminal set).

INSTALLATION

Reverse removal procedure, and then noting the following instructions.

- For tightening torques, refer to structural diagram on previous page.
- Adjust power steering pump drive belt by referring to "INSTALLATION of GENERATOR BELT" in Section 6H.
- Fill specified power steering fluid after installation and bleed air without failure.

TIGHTENING TORQUE SPECIFICATIONS

Fastening parts	Tightening torque		
	N·m	kg·m	lb·ft
Gear box mounting bolts	55	5.5	40.0
Gear box cylinder pipe flare nuts	29	2.9	21.0
Gear box low pressure pipe union bolt	40	4.0	29.0
Gear box high pressure pipe union bolt	35	3.5	25.5
Tie-rod end lock nut	65	6.5	47.0
Pump bracket bolt	25	2.5	18.5
Pump union bolt	60	6.0	43.5
Oil pump mount bolts	25	2.5	18.5
Pipe clamp bolt/Reservoir bracket bolt	11	1.1	8.0
Steering shaft joint bolt	25	2.5	18.0
High pressure flare nuts	40	4.0	29.0
Pump cover bolts	23	2.3	17.0
Pump plug	60	6.0	43.5
Suction connector bolt	10	1.0	7.5
Tie-rod end nut	48	4.8	35.0

REQUIRED SERVICE MATERIALS

MATERIALS	RECOMMENDED SUZUKI PRODUCT	USE
Lithium grease	SUPER GREASE (A) (99000-25010)	<ul style="list-style-type: none"> Oil seal lip of P/S pump pulley shaft
Power steering fluid	An equivalent of DEXRON®-III or DEXRON®-II	<ul style="list-style-type: none"> To fill P/S fluid reservoir Parts lubrication when installing

SPECIAL TOOLS

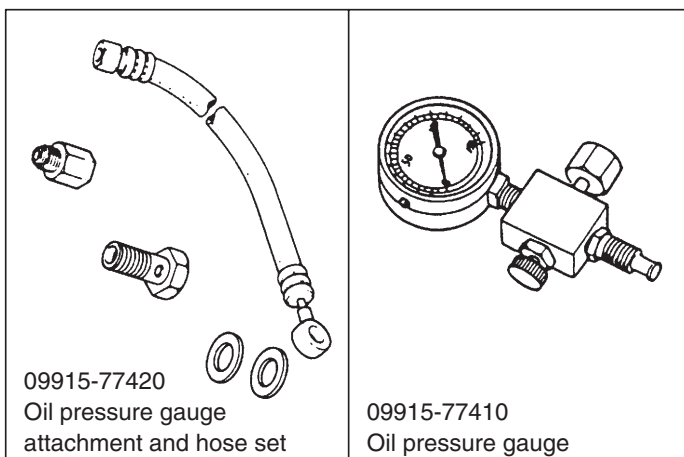

SECTION 3E

REAR SUSPENSION

NOTE:

- For the descriptions (items) not found in this section, refer to the same section of the Service Manual mentioned in the FOREWORD of this manual.
- All suspension fasteners are an important attaching part in that it could affect the performance of vital parts and systems, and/or could result in major repair expense. They must be replaced with one of the same part number or with an equivalent part if replacement becomes necessary. Do not use a replacement part of lesser quality or substitute design. Torque values must be used as specified during reassembly to assure proper retention of this part.
- Never attempt to heat, quench or straighten any suspension part. Replace it with a new part, or damage to the part may result.

3E

CONTENTS

ON-VEHICLE SERVICE	3E-1	TIGHTENING TORQUE SPECIFICATION .	3E-3
REAR AXLE SHAFT AND WHEEL BEARING	3E-1	REQUIRED SERVICE MATERIAL	3E-3
REAR AXLE HOUSING	3E-2	SPECIAL TOOL	3E-4

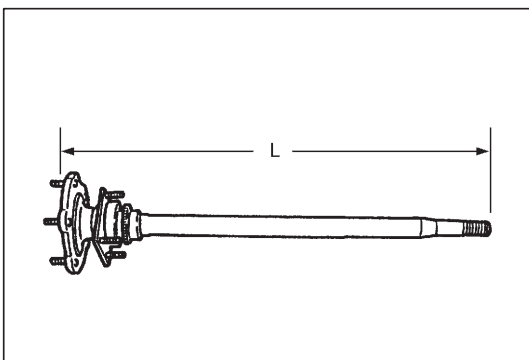

ON-VEHICLE SERVICE

REAR AXLE SHAFT AND WHEEL BEARING

REMOVAL

For the details, refer to the same item of the same section in the service manual mentioned in the FOREWORD of this manual noting following points.

- Rear axle shaft length “L”**
- Left side : 702 mm (27.6 in.)**
- Right side : 771 mm (30.4 in.)**

REAR AXLE HOUSING

INSTALLATION

For the details, refer to the same item of the same section in the Service Manual mentioned in the FOREWORD of this manual noting following points.

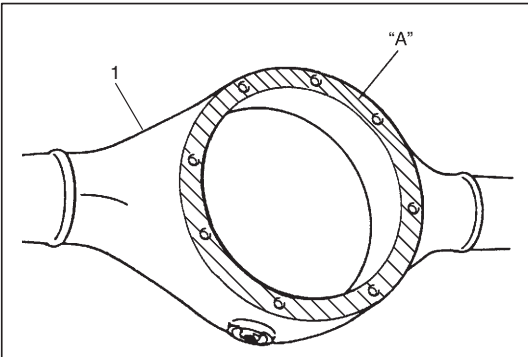

- Clean mating surfaces of axle housing (1) and differential carrier and apply sealant "A" to housing side.

"A": Sealant 99000-31110

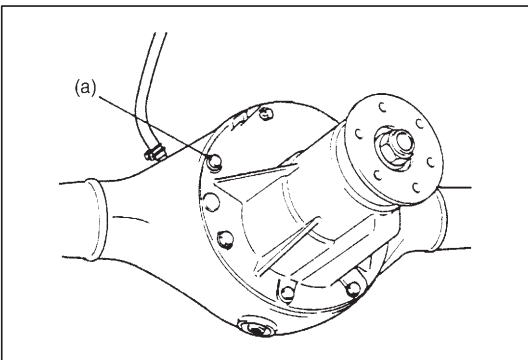

- Install differential carrier assembly to axle housing and tighten carrier bolts to specified torque.

Tightening torque

Differential carrier bolt (a): 55 N·m (5.5 kg·m, 40.0 lb-ft)

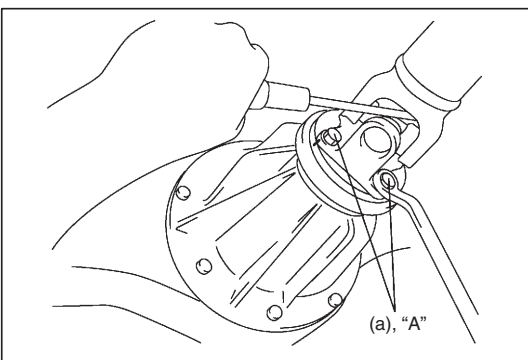

- Apply thread lock cement to thread of propeller shaft flange bolt if reused. Install propeller shaft to joint flange aligning match marks and torque flange bolts or nuts to specification.

"A": Cement 99000-32110

Tightening torque

Propeller shaft bolt or nut (a): 60 N·m (6.0 kg·m, 43.5 lb-ft)

TIGHTENING TORQUE SPECIFICATION

Fastening part	Tightening torque		
	N·m	kg·m	lb·ft
Shock absorber nut	29	2.9	21.0
Shock absorber lower nut	85	8.5	61.5
Lower rod bolt and nut	90	9.0	65.0
Upper rod bolt and nut	90	9.0	65.0
Lateral rod bolt	90	9.0	65.0
Differential carrier bolt	55	5.5	40.0
Propeller shaft bolt or nut	60	6.0	43.5
Brake pipe flare nut	16	1.6	11.5
Bearing retainer nut	23	2.3	17.0
Differentiation gear oil filler & drain plug (filler plug)	50	5.0	36.5
Differentiation gear oil filler & drain plug (drain plug)	27	2.7	16.0
Wheel nut	100	10.0	72.5
Wheel speed sensor bolt	21	2.1	15.5

REQUIRED SERVICE MATERIAL

Material	Recommended SUZUKI product (Part Number)	Use
Lithium grease	SUZUKI SUPER GREASE A (99000-25010)	● Oil seal lip
Brake fluid	DOT 3	● Brake reservoir tank
Sealant	SUZUKI BOND NO.1215 (99000-31110)	<ul style="list-style-type: none"> ● Joint seam of axle and brake back plate ● Joint seam of bearing retainer and brake back plate ● Joint seam of differential carrier and axle housing ● Drain plug ● Mating surface of oil seal and axle housing
Gear oil	For gear oil information, refer to Section 7F	● Differential gear (Rear axle housing)
Thread lock cement	THREAD LOCK CEMENT SUPER 1322 (99000-32110)	● Rear propeller shaft flange bolts

SPECIAL TOOL

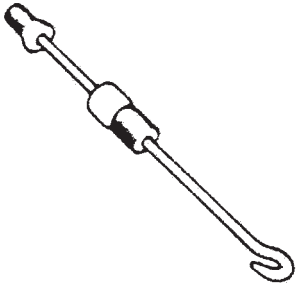

09942-15510
Sliding hammer

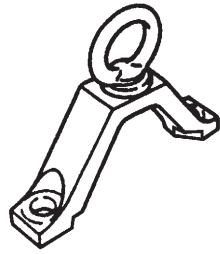

09943-35512
Brake drum remover



09944-88210
Bearing installer

SECTION 4A2

FRONT DRIVE SHAFT/SHAFT BEARING, OIL SEAL

NOTE:

For the descriptions (items) not found in this section, refer to the same section of the Service Manual mentioned in the FOREWORD of this manual.

4A2

CONTENTS

ON-VEHICLE SERVICE	4A2-2
Drive Shaft	4A2-2
REQUIRED SERVICE MATERIAL	4A2-4

ON-VEHICLE SERVICE

DRIVE SHAFT ASSEMBLY

CAUTION:

- To prevent any problem caused by washing solution, do not wash joint boots. Degreasing of those parts with cloth is allowed.
- Bend each boot band against forward rotation.
- Do not squeeze or distort boot when fastening it with bands.
Distorted boot caused by squeezing air may reduce its durability.

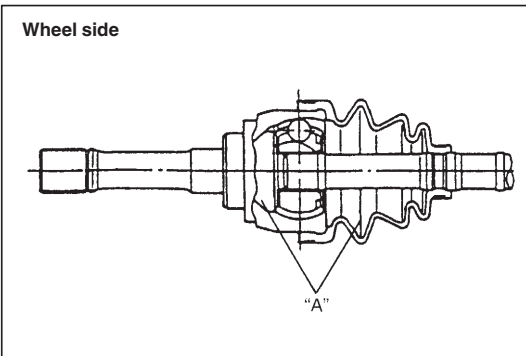

- 1) Fully apply joint grease to wheel side joint.
Use joint grease in the tube included in spare part.

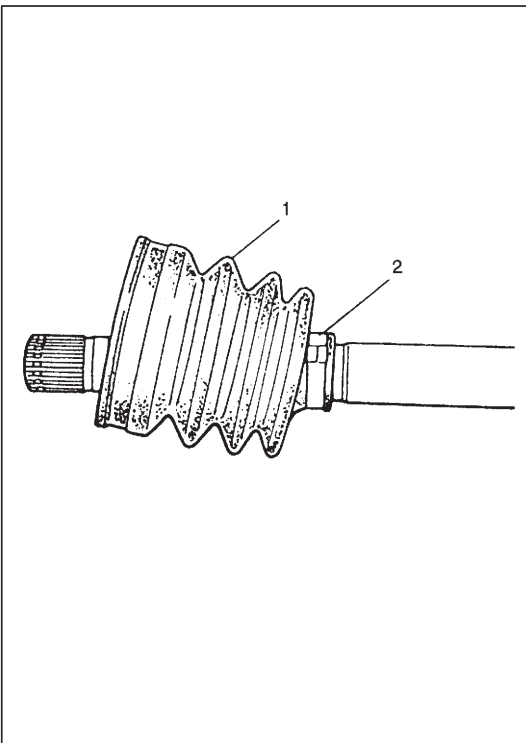

- 2) Fit wheel side boot on shaft.
Fill up inside of boot with remainder of joint grease of about 90 gram.
Before fixing boot band, insert screwdriver into boot on joint side and allow air to enter boot so that air pressure in boot becomes the same as atmospheric pressure.

“A”: Joint Grease

(about 70 – 80 g (2.5 – 2.8 oz) (Black)) (for A/T vehicle)
(about 85 – 95 g (3.0 – 3.4 oz) (Yellow)) (for M/T vehicle)

- 3) Fixing boot band.
- 4) Install boot (1) onto drive shaft till its small diameter side fits to shaft groove and fix there with boot band (2).

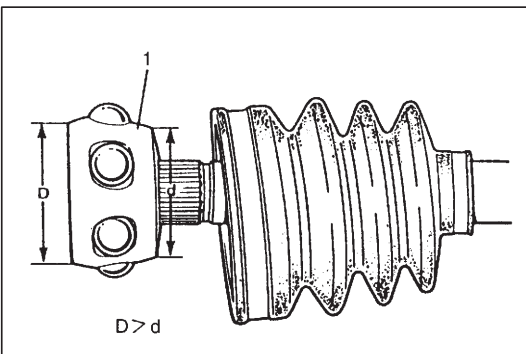

- 5) Install cage (1) to shaft.

CAUTION:

Install cage directing smaller outside diameter side to shaft end.

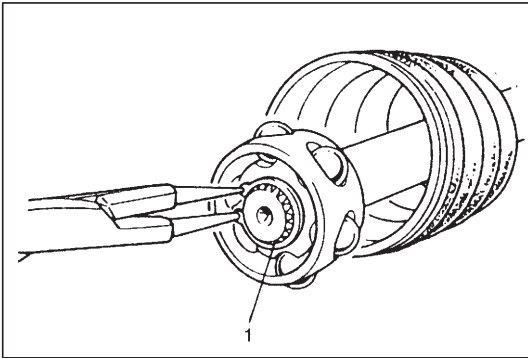

6) Install circlip (1) by using snap ring plier.

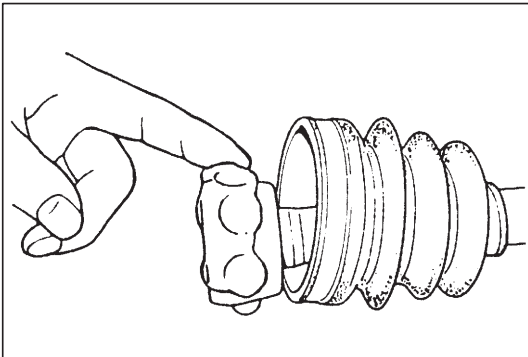

7) Apply grease to entire surface of cage.
Use joint grease in tube included in spare part.

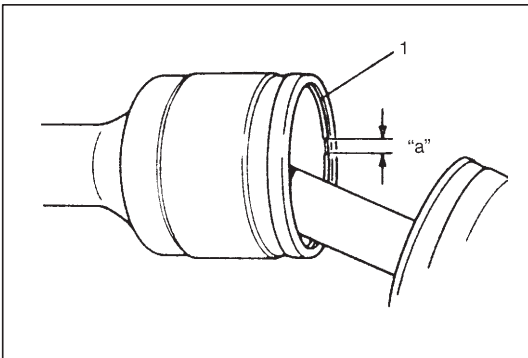

8) Insert cage into outer race and fit circlip (1) into groove of outer race.

CAUTION:
Position opening of circlip "a" so that it will not be lined up with a ball.

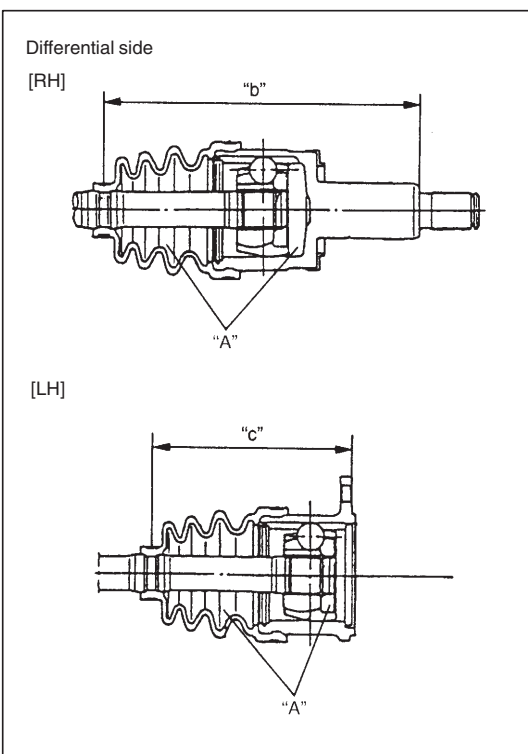

9) Apply grease in tube included in spare part to inside of outer race, and fit boot to outer race.
Fill up inside of boot with joint grease.

"A": Joint Grease (about 90 – 100 g /3.2 – 3.5 oz)

10) Fitting boot to outer race, adjust so that measurements "b" and "c" become as indicated in figure.

- Length "b": 203.2 – 213.2 mm**
(8.00 – 8.40 in.) (for A/T vehicle)
196.8 – 206.8 mm
(7.75 – 8.14 in.) (for M/T vehicle)
- "c": 125.5 – 135.5 mm**
(4.94 – 5.33 in.) (for A/T vehicle)
127.5 – 137.5 mm
(5.02 – 5.41 in.) (for M/T vehicle)

Before fixing boot band, insert screwdriver into boot on joint side and allow air to enter boot so that air pressure in boot becomes the same as atmospheric pressure.

11) Clamp boot band. Check boots for distortion or dent.

REQUIRED SERVICE MATERIAL

MATERIAL	RECOMMENDED SUZUKI PRODUCT	USE
Lithium grease	SUZUKI SUPER GREASE A (99000-25010)	Drive shaft oil seal Wheel spindle part of differential side drive shaft (RH)
Sealant	SEALING COMPOUND 366E (99000-31090)	Axle shaft drive flange

SECTION 4B

PROPELLER SHAFTS

NOTE:

For the descriptions (items) not found in this section, refer to the same section of the Service Manual mentioned in the FOREWORD of this manual.

CONTENTS

ON-VEHICLE SERVICE	4B-2
Propeller Shaft	4B-2
TIGHTENING TORQUE SPECIFICATION	4B-2

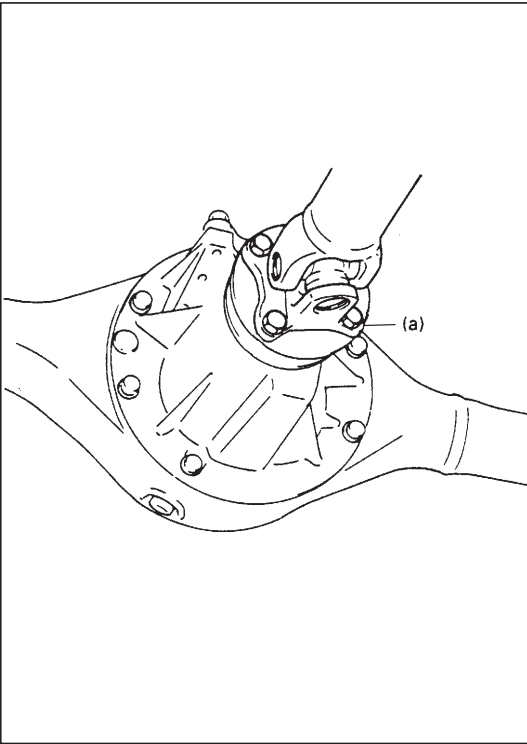

ON-VEHICLE SERVICE

PROPELLER SHAFT

INSTALLATION

Reverse removal procedure to install propeller shaft.

- Use following specification to torque universal joint flange bolts and nuts.

Tightening Torque

Front propeller shaft flange nuts:

50 N·m (5.0 kg-m, 36.5 lb-ft)

Rear propeller shaft flange bolts (a):

60 N·m (6.0 kg-m, 43.5 lb-ft)

- When installing propeller shaft, align the match marks. Otherwise, vibration may occur during driving.

NOTE:

If transfer oil was drained for front propeller shaft removal, pour specified gear oil into transfer case to specified level.

TIGHTENING TORQUE SPECIFICATION

Fastener	Tightening torque		
	N·m	kg-m	lb-ft
Front propeller shaft flange nuts	50	5.0	36.5
Rear propeller shaft flange bolts	60	6.0	43.5

SECTION 6

ENGINE GENERAL INFORMATION AND DIAGNOSIS

(RHZ ENGINE WITH SINGLE-CONNECTOR ECM)

WARNING:

For vehicles equipped with Supplemental Restraint (Air Bag) System:

- Service on and around the air bag system components or wiring must be performed only by an authorized SUZUKI dealer. Refer to “Air Bag System Components and Wiring Location View” under “General Description” in air bag system section in order to confirm whether you are performing service on or near the air bag system components or wiring. Please observe all WARNINGS and “Service Precautions” under “On-Vehicle Service” in air bag system section before performing service on or around the air bag system components or wiring. Failure to follow WARNINGS could result in unintentional activation of the system or could render the system inoperative. Either of these two conditions may result in severe injury.
- Technical service work must be started at least 90 seconds after the ignition switch is turned to the “LOCK” position and the negative cable is disconnected from the battery. Otherwise, the system may be activated by reserve energy in the Sensing and Diagnostic Module (SDM).

6

CONTENTS

GENERAL INFORMATION	6- 3	Table A-2 MIL Circuit Check (MIL remains ON)	6- 29
ENGINE DIAGNOSIS	6- 6	Table A-3 ECM (PCM) Power and Ground Circuit Check	6- 29
General Description	6- 6	DTC P0100 (DTC P0100) MAF Circuit Malfunction	6- 31
On-Board Diagnostic System	6- 6	DTC P0101 (P0100) MAF Sensor Circuit Range/Performance Problem	6- 33
Precaution in Diagnosing Trouble	6- 9	DTC P0110 IAT Circuit Malfunction	6- 34
Engine Diagnostic Flow Table	6- 10	DTC P0115 (DTC P0115) Engine Coolant Temp. Sensor Circuit Malfunction	6- 36
Customer Problem Inspection Form	6- 12	DTC P0121 (DTC P0120) TP Circuit Range/Performance Problem	6- 37
Malfunction Indicator Lamp (MIL) Check	6- 13	DTC P0604 (P0120) TP Sensor Monitoring System Malfunction	6- 37
Diagnostic Trouble Code (DTC) Check	6- 13	DTC P0180 Fuel Temp. Sensor Circuit Malfunction	6- 39
Diagnostic Trouble Code (DTC) Clearance	6- 13	DTC P0190 (P0190) Fuel Rail Pressure Sensor Circuit Malfunction	6- 40
Fail-Safe Table	6- 14	DTC P0191 (P0230) Fuel Rail Pressure Sensor/Pressure Regulator Consistency Function	6- 42
Diagnostic Trouble Code (DTC) Table ...	6- 15		
Visual Inspection	6- 18		
Engine Basic Check	6- 19		
Engine Diagnosis Table	6- 20		
Inspection of PCM (ECM) and Its Circuits	6- 25		
Voltage Check	6- 25		
Resistance Check	6- 27		
Table A-1 MIL Circuit Check (MIL does not come ON)	6- 28		

DTC P1112 (P0230) Fuel Pressure Monitoring Circuit Malfunction	6- 42	DTC P1108 Radiator Fan High Speed Circuit Malfunction	6- 56
DTC P0201 (P0200) Injector Circuit Malfunction Cylinder 1	6- 44	DTC P1109 Radiator Fan Low Speed Circuit Malfunction	6- 57
DTC P0202 (P0200) Injector Circuit Malfunction Cylinder 2	6- 44	DTC P1110 A/C Signal Circuit Malfunction	6- 58
DTC P0203 (P0200) Injector Circuit Malfunction Cylinder 3	6- 44	DTC P1135 3rd Piston Deactivator Circuit Malfunction	6- 59
DTC P0204 (P0200) Injector Circuit Malfunction Cylinder 4	6- 44	DTC P1138 (P0230) Fuel Pressure Regulator Circuit Malfunction	6- 60
DTC P0215 Double Relay Circuit Malfunction	6- 46	DTC P1402 (P0510) Throttle Solenoid Valve Circuit Malfunction	6- 61
DTC P0230 Fuel Pump Supply Circuit Malfunction	6- 47	DTC P1511 Ignition Switch Circuit Malfunction	6- 62
DTC P0243 (P0243) Turbo Pressure Solenoid Valve Circuit Range/Performance Problem	6- 48	DTC P1519 Radiator Fan Circuit Malfunction	6- 63
DTC P0245 (P0243/P0246 (P0243) Turbo Pressure Solenoid Valve Circuit Range/Performance Problem	6- 50	DTC P1606 MIL Circuit Malfunction	6- 64
DTC P0380 (P0380) Pre/Post Heat Relay Circuit Malfunction	6- 51	DTC P1608 ECT Warning Lamp Circuit Malfunction	6- 65
DTC P0381 Glow Indicator Lamp Circuit Malfunction	6- 52	DTC P1614 (P0560) Sensor Supply Function	6- 66
DTC P0401 (P0903) EGR Solenoid Valve Flow Insufficient Defected	6- 53	DTC P0221 (P0220) TP Range/Performance Problem	6- 67
DTC P0402 (P0903) EGR Solenoid Valve Flow Excessive Detected	6- 53	DTC P0335 (P0335) CKP Sensor Circuit Malfunction	6- 68
DTC P0403 (P0403) EGR Solenoid Valve Circuit Malfunction	6- 54	DTC P0340 (P0335/P0340) CMP Sensor Circuit Malfunction	6- 70
DTC P0561 Stabilization of Sensor Supply	6- 55	DTC P0500 (P0500) Vehicle Speed Sensor Circuit Malfunction	6- 72
DTC P0603/P0606!!G/P1171/P1617 ECM Function	6- 55	DTC P0235 (P0235) Intake Air Pressure Sensor Circuit Malfunction	6- 74
DTC P1169 (P0170) Condenser Voltage Function 1	6- 55	DTC P0560 (P0560) Power Supply Circuit Malfunction	6- 76
DTC P1170 (P0170) Condenser Voltage Function 2	6- 55	Table B-1 Fuel Pump Circuit Inspection	6- 77
DTC P1101 (P0105) Barometric Pressure Sensor Circuit Malfunction	6- 55	Table B-2 Fuel Pressure Inspection	6- 78

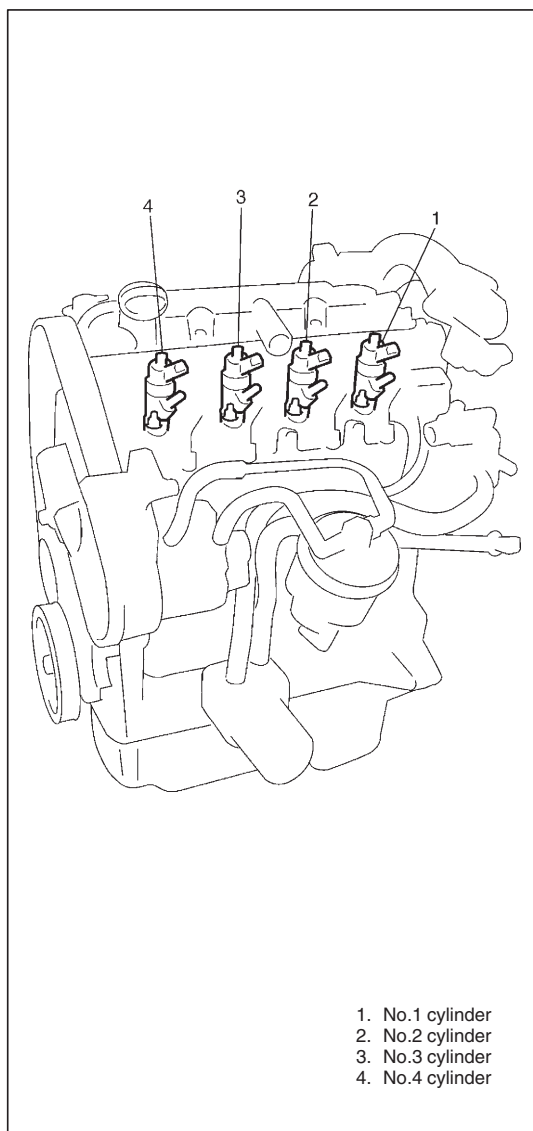

GENERAL INFORMATION

STATEMENT OF CLEANLINESS AND CARE

An automobile engine is a combination of many machined, honed, polished and lapped surfaces with tolerances that are measured in the thousands of an millimeter (ten thousands of inch). Accordingly, when any internal engine parts are serviced, care and cleanliness are important. Throughout this section, it should be understood that proper cleaning and protection of machined surfaces and friction areas is part of the repair procedure. This is considered standard shop practice even if not specifically stated.

- A liberal coating of engine oil should be applied to friction areas during assembly to protect and lubricate the surface on initial operation.
- Whenever valve train components, pistons, piston rings, connecting rods, rod bearings and crankshaft journal bearings are removed for service, they should be retained in order. At the time of installation, they should be installed in the same locations and with the same mating surfaces as when removed.
- Battery cables should be disconnected before any major work is performed on the engine. Failure to disconnect cables may result in damage to wire harness or other electrical parts.
- Throughout this manual, the four cylinders of the engine are identified by numbers: No.1, No.2, No.3 and No.4 as counted from flywheel side to crankshaft pulley side.

GENERAL INFORMATION ON ENGINE SERVICE

THE FOLLOWING INFORMATION ON ENGINE SERVICE SHOULD BE NOTED CAREFULLY, AS IT IS IMPORTANT IN PREVENTING DAMAGE, AND IN CONTRIBUTING TO RELIABLE ENGINE PERFORMANCE.

- When raising or supporting engine for any reason, do not use a jack under oil pan. Due to small clearance between oil pan and oil pump strainer, jacking against oil pan may cause it to be bent against strainer resulting in damaged oil pick-up unit.
- It should be kept in mind, while working on engine, that 12-volt electrical system is capable of violent and damaging short circuits. When performing any work where electrical terminals could possibly be grounded, ground cable of the battery should be disconnected at battery.
- Any time the air cleaner, air cleaner outlet hose, intercooler, intercooler outlet hose, throttle valve assembly or intake manifold is removed, the intake opening should be covered. This will protect against accidental entrance of foreign material which could follow intake passage into cylinder and cause extensive damage when engine is started.

With short pipe, fit hose as far as it reaches pipe joint as shown.

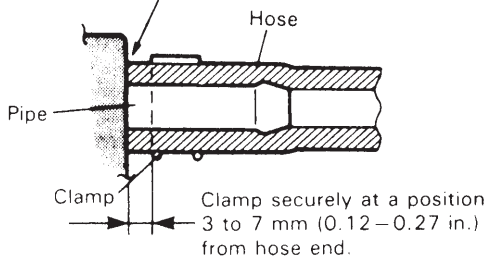

With following type pipe, fit hose as far as its peripheral projection as shown.

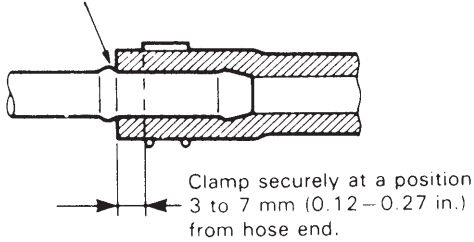

With bent pipe, fit hose as far as its bent part as shown or till pipe is about 20–30 mm (0.79–1.18 in.) into hose.

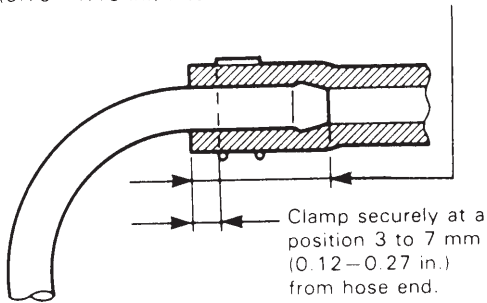

With straight pipe, fit hose till pipe is about 20 to 30 mm (0.79–1.18 in.) the hose.

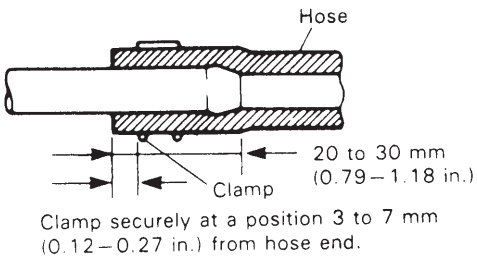

PRECAUTION ON FUEL SYSTEM SERVICE

- Work must be done with no smoking, in a well-ventilated area and away from any open flames.
- A small amount of fuel may be released after fuel line is disconnected.

In order to reduce the chance of personal injury, cover fitting to be disconnected with a shop cloth. Put that cloth in an approved container when disconnection is completed.

- Never run engine with double relay disconnected when engine and exhaust system are hot.
- Fuel or fuel vapor hose connection varies with each type of pipe. When reconnecting fuel or fuel vapor hose, be sure to connect and clamp each hose correctly referring to figure “Hose Connection”.

After connecting, make sure that it has no twist or kink.

- When installing fuel filter union bolt or plug bolt on union bolt, always use new gasket and tighten it to specified torque. See Section 6C for specified torque.
- When installing injector, fuel feed pipe or fuel pressure regulator, lubricate its O-ring with spindle oil or fuel.
- When connecting fuel pipe flare nut, first tighten flare nut by hand and then tighten it to specified torque, using back-up wrench.

FUEL PRESSURE RELIEF PROCEDURE

Refer to “Fuel Delivery System Precaution” in Section 6E3.

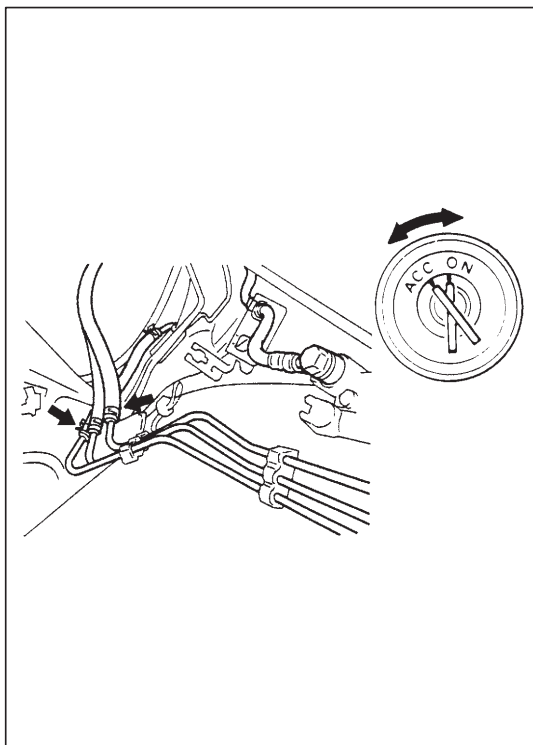

FUEL LEAKAGE CHECK PROCEDURE

After performing any service on fuel system, check to make sure that there are no fuel leakages as follows.

- 1) Turn ON ignition switch for 5 seconds (to operate fuel pump) and then turn it OFF. Repeat this (ON and OFF) 3 or 4 times and apply fuel pressure to fuel line (till fuel pressure is felt by hand placed on fuel return hose).
- 2) In this state, check to see that there are no fuel leakages from any part of low pressure fuel system between fuel pump and injection pump.
- 3) Check that there are no fuel leakages from any part of high pressure fuel system between injection pump and fuel injector by performing the procedure below.
 - (1) Start engine and warm up to normal operating temperature.
 - (2) Check fuel leakage after turning off ignition switch.
 - (3) Again, start engine and accelerate the vehicle up to 3500 rpm with L range (AT) or 1st gear (MT). Then stop vehicle.
 - (4) Check fuel leakage after turning off ignition switch.

ENGINE DIAGNOSIS

GENERAL DESCRIPTION

This vehicle is equipped with an engine and emission control system which are under control of ECM (PCM). The engine and emission control system in this vehicle are controlled by ECM (PCM). ECM (PCM) has an On-Board Diagnostic system which detects a malfunction in this system and abnormality of those parts that influence the engine exhaust emission. When diagnosing engine troubles, be sure to have full understanding of the outline of "On-Board Diagnostic System" and each item in "Precaution in Diagnosing Trouble" and execute diagnosis according to "ENGINE DIAGNOSTIC FLOW TABLE".

There is a close relationship between the engine mechanical, engine cooling system, exhaust system, etc. and the engine and emission control system in their structure and operation. In case of an engine trouble, even when the malfunction indicator lamp (MIL) doesn't turn ON, it should be diagnosed according to this flow table.

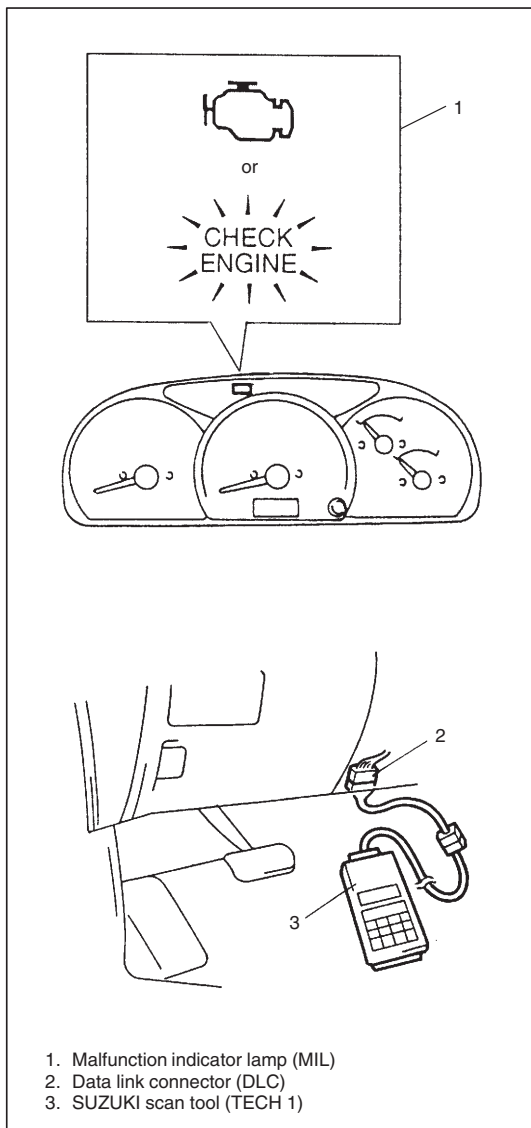

ON-BOARD DIAGNOSTIC SYSTEM

ECM (PCM) in this vehicle has the following functions.

- When the ignition switch is turned ON with the engine at a stop, MIL turns ON to check the bulb of the malfunction indicator lamp (MIL).
- When ECM (PCM) detects a malfunction which gives an adverse effect to vehicle emission while the engine is running, it makes the malfunction indicator lamp in the meter cluster of the instrument panel turn ON and stores the malfunction area in its memory.
- As a condition for detecting a malfunction in some areas in the system being monitored by ECM (PCM) and turning ON the malfunction indicator lamp due to that malfunction, 2 driving cycles detection logic is adopted to prevent erroneous detection.
- When a malfunction is detected, engine and driving conditions then are stored in ECM (PCM) memory as freeze frame data. (For the details, refer to description on Freeze frame data.)
- It is possible to communicate by using not only SUZUKI scan tool but also generic scan tool. (Diagnostic information can be accessed by using a scan tool.)

Warm-Up Cycle

A “warm-up cycle” means sufficient vehicle operation such that the coolant temperature has risen by at least 22°C (40°F) from engine starting and reaches a minimum temperature of 70°C (160°F).

Driving Cycle

A “driving cycle” consists of two parts, engine startup and engine shutoff.

2 Driving Cycle Detection Logic

The malfunction detected in the first driving cycle is stored in ECM (PCM) memory (in the form of pending DTC) but the malfunction indicator lamp does not light at this time. It lights up at the second detection of same malfunction also in the next driving cycle.

Pending Diagnostic Trouble Code (DTC)

NOTE:

Pending diagnostic trouble code can be read using generic scan tool or Euro mode of Suzuki scan tool.

Pending DTC means a DTC detected and stored temporarily at 1 driving cycle of the DTC which is detected in the 2 driving cycle detection logic.

Freeze Frame Data

NOTE:

Freeze frame data can be read using generic scan tool or Euro mode of Suzuki scan tool.

ECM (PCM) stores the engine and driving conditions (in the form of data as shown at the left) at the moment of the detection of a malfunction in its memory. This data is called “Freeze frame data”.

Therefore, it is possible to know engine and driving conditions (e.g., whether the engine was warm or not, where the vehicle was running or stopped) when a malfunction was detected by checking the freeze frame data.

Priority of freeze frame data:

As ECM can store freeze frame data for one malfunction only, the freeze frame data shown as 1 below has a priority for storage. (If malfunction as described in the upper square “1” below is detected while the freeze frame data in the lower square “2” has been stored, the freeze frame data “2” will be updated by the freeze frame data “1”.)

An Example of Freeze Frame Data

1. Trouble Code	P0102
2. Engine Speed	782 RPM
3. Eng Cool Tmp	80°C
4. Vehicle Spd.	0 km/h
5. MAP Sensor	39kPa
6. St. Term FT1	-0.8% Lean
7. Lg. Term FT1	-1.6% Lean
8. Fuel 1 Stat.	Closed Loop
9. Fuel 2 Stat.	Not used
10. Load value	25.5%

PRIORITY	FREEZE FRAME DATA
1	Freeze frame data at initial detection of diagnostic trouble codes below. P0100, P0120, P0170, P0190, P0200, P0220, P0230, P0235, P0243, P0560, P0903
2	Freeze frame data when a diagnostic trouble code other than those in “1” above is detected.

Freeze frame data clearance:

The freeze frame data is cleared at the same time as clearance of diagnostic trouble code (DTC).

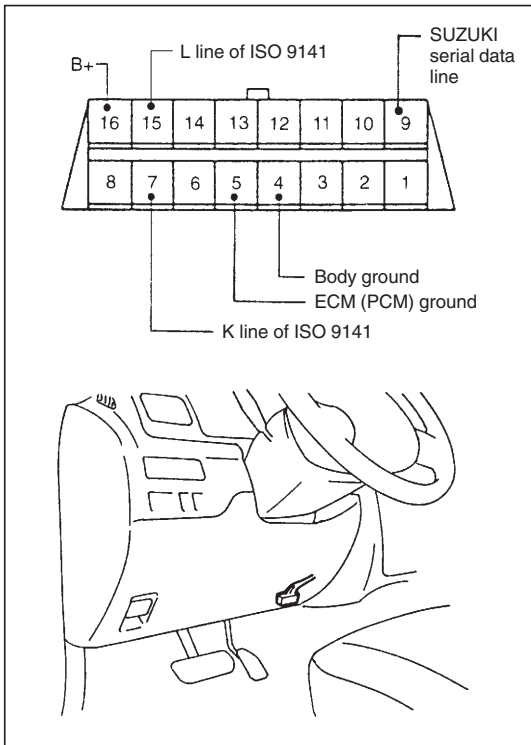

Data Link Connector (DLC)

DLC in compliance with SAE J1962 in its installation position, the shape of connector and pin assignment.

K and L lines of ISO 9141 is used for SUZUKI scan tool or generic scan tool to communication with ECM (PCM), ABS control module and TCM.

SUZUKI serial data line is used for SUZUKI scan tool to communicate with an electronic control unit (Airbag SDM, etc.).

PRECAUTION IN DIAGNOSING TROUBLE

- Don't disconnect couplers from ECM (PCM), battery cable from battery, ECM (PCM) ground wire harness from engine or main fuse before confirming diagnostic information (DTC, freeze frame data, etc.) stored in ECM (PCM) memory.
- Diagnostic information stored in ECM (PCM) memory can be cleared as well as checked by using SUZUKI scan tool or generic scan tool. Before using scan tool, read its Operator's (Instruction) Manual carefully to have good understanding as to what functions are available and how to use it.
- Priorities for diagnosing troubles

If troubleshooting priorities for multiple diagnostic code are given in the applicable diagnostic chart, these should be followed.

If no instructions are given, troubleshoot diagnostic trouble codes according to the following priorities.

(1) Fuel pressure (P1112 for Suzuki mode of Suzuki scan tool/P0230 for generic scan tool)

(2) Diagnostic trouble codes other than listed below

DTC indicated by generic scan tool or Euro mode of Suzuki scan tool	DTC indicated by Suzuki mode of Suzuki scan tool
P0100, P0120, P0170, P0190, P0200, P0220, P0230, P0235, P0243, P0560, P0903	P0100, P0101, P0121, P0604, P1169, P1170, P0190, P0201, P0202, P0203, P0204, P0221, P1112, P1138, P0235, P0243, P0245, P0246, P0560, P0561, P0401, P0402

(3) Diagnostic trouble codes described in above list

- Be sure to read "Precautions for Electrical Circuit Service" in Section 0A before inspection and observe what is written there.
- ECM (PCM) replacement or substitution
When substituting a known-good ECM, check for following conditions. Neglecting this check may cause damage to known-good ECM.
 - Resistance value of all relays, actuators is as specified respectively.
 - MAF sensor is in good condition and none of power circuit of its sensor is shorted to ground.
- ECU code registration
If ECM is replaced after servicing engine and emission control system, register ECU code into ECM by performing procedure described in "Procedure after ECM Replacement" of Section 8G. Or ECM dose not function as Immobilizer Control System.

ENGINE DIAGNOSTIC FLOW TABLE

Refer to the following pages for the details of each step.

STEP	ACTION	YES	NO
1	Customer Complaint Analysis 1) Perform customer complaint analysis. Was customer complaint analysis performed?	Go to Step 2.	Perform customer complaint analysis.
2	Diagnostic Trouble Code (DTC) and Freeze Frame Data Check, Record and Clearance 1) Check for DTC referring to the next page. Is there any DTC(s)?	1) Print DTC and freeze frame data or write them down and clear by referring to "DTC Clearance" in this section. 2) Go to Step 3.	Go to Step 4.
3	Visual Inspection 1) Perform Visual inspection referring to the "Visual Inspection" in this section. Is there any faulty condition?	1) Repair or replace malfunction part. 2) Go to Step 11.	Go to Step 5.
4	Visual Inspection 1) Perform visual inspection referring to the "Visual Inspection" in this section. Is there any faulty condition?		Go to Step 8.
5	Trouble Symptom Confirmation 1) Confirm trouble symptom referring to the "Trouble Symptom Confirmation" in this section. Is trouble symptom identified?	Go to Step 6.	Go to Step 7.
6	Rechecking and Record of DTC/Freeze Frame Data 1) Recheck for DTC and freeze frame data referring to "DTC Check" in this section. Is there any DTC(s)?	Go to Step 9.	Go to Step 8.
7	Rechecking and Record of DTC/Freeze Frame Data 1) Recheck for DTC and freeze frame data referring to "DTC Check" in this section. Is there any malfunction DTC(s)?		Go to Step 10.
8	Engine Basic Inspection and Engine Diagnosis Table 1) Check and repair according to "Engine Basic Check" and "Engine Diagnosis Table" in this section. Are check and repair complete?	Go to Step 11.	1) Check and repair malfunction part(s). 2) Go to Step 11.
9	Troubleshooting for DTC 1) Check and repair according to applicable DTC diag. flow table in this section. Are check and repair complete?		
10	Check for Intermittent Problems 1) Check for intermittent problems referring to the next page. Is there any faulty condition?	1) Repair or replace malfunction part(s). 2) Go to Step 11.	Go to Step 11.
11	Final Confirmation Test 1) Clear DTC if any. 2) Perform final confirmation test referring to the next page. Is there any problem symptom, DTC or abnormal condition?	Go to Step 6.	End.

1. CUSTOMER COMPLAINT ANALYSIS

Record details of the problem (failure, complaint) and how it occurred as described by the customer. For this purpose, use of such an inspection form will facilitate collecting information to the point required for proper analysis and diagnosis.

2. DIAGNOSTIC TROUBLE CODE (DTC)/FREEZE FRAME DATA CHECK, RECORD AND CLEARANCE

First, check DTC (including pending DTC), referring to “DTC check” section. If DTC is indicated, print it and freeze frame data or write them down and then clear them by referring to DTC clearance section. DTC indicates malfunction that occurred in the system but does not indicate whether it exists now or it occurred in the past and the normal condition has been restored now. To check which case applies, check the symptom in question according to Step 5 and recheck DTC according to Step 6 and 7.

Attempt to diagnose a trouble based on DTC in this step only or failure to clear the DTC (including pending DTC) in this step will lead to incorrect diagnosis, trouble diagnosis of a normal circuit or difficulty in troubleshooting.

NOTE:

- If DTC P1112 (for Suzuki mode of Suzuki scan tool) or P0230 (for generic scan tool or Euro mode of Suzuki scan tool) is indicated in this step, proceed to Diag. flow table for DTC P1112/P0230 first.
- Ignore DTC P1517 though it may be indicated on Suzuki scan tool. It does not affect engine and emission control system and immobilizer control system.

3 and 4. VISUAL INSPECTION

As a preliminary step, be sure to perform visual check of the items that support proper function of the engine referring to “Visual Inspection” section.

5. TROUBLE SYMPTOM CONFIRMATION

Based on information obtained in Step 1 Customer complaint analysis and Step 2 DTC/freeze frame data check, confirm trouble symptoms. Also, reconfirm DTC according to “DTC Confirmation Procedure” described in each DTC Diagnosis section.

6 and 7. DTC/FREEZE FRAME DATA RECHECK, RECORD AND CLEARANCE

Refer to “DTC CHECK” section for checking procedure.

8. ENGINE BASIC CHECK AND ENGINE DIAGNOSIS TABLE

Perform basic engine check according to the “Engine Basic Check Flow Table” first. When the end of the flow table has been reached, check the parts of the system suspected as a possible cause referring to “Engine Diagnosis Table” and based on symptoms appearing on the vehicle (symptoms obtained through steps of customer complaint analysis, trouble symptom confirmation and/or basic engine check) and repair or replace faulty parts, if any.

9. TROUBLESHOOTING FOR DTC (See each DTC Diag. Flow Table)

Based on the DTC indicated in Step 6 or 7 and referring to the applicable DTC diag. flow table in this section, locate the cause of the trouble, namely in a sensor, switch, wire harness, connector, actuator, ECM (PCM) or other part and repair or replace faulty parts.

10. CHECK FOR INTERMITTENT PROBLEM

Check parts where an intermittent trouble is easy to occur (e.g., wire harness, connector, etc.), referring to “INTERMITTENT AND POOR CONNECTION” in Section 0A and related circuit of DTC recorded in Step 2.

11. FINAL CONFIRMATION TEST

Confirm that the problem symptom has gone and the engine is free from any abnormal conditions. If what has been repaired is related to the DTC, clear the DTC once and perform DTC confirmation procedure and confirm that no DTC is indicated.

CUSTOMER PROBLEM INSPECTION FORM (EXAMPLE)

User name:	Model:	VIN:	
Date of issue:	Date Reg.	Date of problem:	Mileage:
PROBLEM SYMPTOMS			
<input type="checkbox"/> Difficult Starting		<input type="checkbox"/> Poor Driveability	
<input type="checkbox"/> No cranking <input type="checkbox"/> No initial combustion <input type="checkbox"/> Poor starting at (<input type="checkbox"/> Cold/ <input type="checkbox"/> Warm/ <input type="checkbox"/> Always) <input type="checkbox"/> Other _____		<input type="checkbox"/> Hesitation on acceleration <input type="checkbox"/> Back fire/After fire <input type="checkbox"/> Loss of power <input type="checkbox"/> Surging <input type="checkbox"/> Abnormal knocking <input type="checkbox"/> Other _____	
<input type="checkbox"/> Poor Idling		<input type="checkbox"/> Engine Stall when	
<input type="checkbox"/> Poor fast idle <input type="checkbox"/> Abnormal idling speed (<input type="checkbox"/> High <input type="checkbox"/> Low) (r/min.) <input type="checkbox"/> Unstable <input type="checkbox"/> Hunting (r/min. to r/min.) <input type="checkbox"/> Other _____		<input type="checkbox"/> Immediately after start <input type="checkbox"/> Accel. pedal is depressed <input type="checkbox"/> Accel. pedal is released <input type="checkbox"/> Load is applied <input type="checkbox"/> A/C <input type="checkbox"/> Electrical load <input type="checkbox"/> P/S <input type="checkbox"/> Other _____	
<input type="checkbox"/> OTHERS:			
VEHICLE/ENVIRONMENTAL CONDITION WHEN PROBLEM OCCURS			
Environmental Condition			
Weather	<input type="checkbox"/> Fair <input type="checkbox"/> Cloudy <input type="checkbox"/> Rain <input type="checkbox"/> Snow <input type="checkbox"/> Always <input type="checkbox"/> Other _____ (°F/ °C)		
Temperature	<input type="checkbox"/> Hot <input type="checkbox"/> Warm <input type="checkbox"/> Cool <input type="checkbox"/> Cold <input type="checkbox"/> Always		
Frequency	<input type="checkbox"/> Always <input type="checkbox"/> Sometimes (times/ day, month) <input type="checkbox"/> Only once <input type="checkbox"/> Under certain condition		
Road	<input type="checkbox"/> Urban <input type="checkbox"/> Suburbs <input type="checkbox"/> Highways <input type="checkbox"/> Mountainous (<input type="checkbox"/> Uphill <input type="checkbox"/> Downhill) <input type="checkbox"/> Paved road <input type="checkbox"/> Gravel <input type="checkbox"/> Other _____		
Vehicle Condition			
Engine condition	<input type="checkbox"/> Cold <input type="checkbox"/> Warming up phase <input type="checkbox"/> Warmed up <input type="checkbox"/> Always <input type="checkbox"/> Other at starting <input type="checkbox"/> Immediately after start/ <input type="checkbox"/> Racing without load <input type="checkbox"/> Engine speed (r/min.)		
Vehicle condition	<input type="checkbox"/> During driving: <input type="checkbox"/> Constant speed (km/h, mile/h) <input type="checkbox"/> Accelerating <input type="checkbox"/> Decelerating <input type="checkbox"/> Right hand corner <input type="checkbox"/> Left hand corner <input type="checkbox"/> When shifting (Lever position) <input type="checkbox"/> At stop <input type="checkbox"/> Other ()		
Malfunction indicator lamp condition	<input type="checkbox"/> Always ON <input type="checkbox"/> Sometimes ON <input type="checkbox"/> Always OFF <input type="checkbox"/> Good condition <input type="checkbox"/> Flashing		
Diagnostic trouble code	First check: <input type="checkbox"/> No code <input type="checkbox"/> Malfunction code ()		
	Second check: <input type="checkbox"/> No code <input type="checkbox"/> Malfunction code ()		

NOTE:

The above form is standard sample. It should be modified according to conditions characteristic of each market.

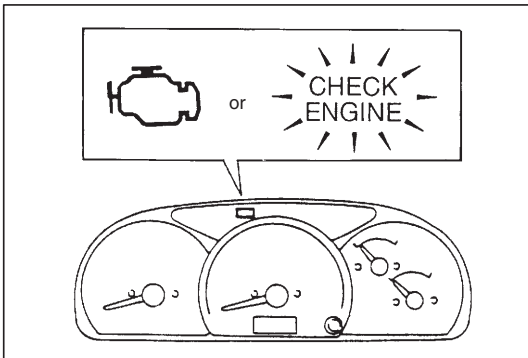

MALFUNCTION INDICATOR LAMP (MIL) CHECK

- 1) Turn ON ignition switch (but the engine at stop) and check that MIL lights.
If MIL does not light up or dims, go to “Diagnostic Flow Table A-1” for troubleshooting.
- 2) Start engine and check that MIL turns OFF.
If MIL remains ON, and no DTC is stored in ECM (PCM), go to “Diagnostic Flow Table A-2” for troubleshooting.

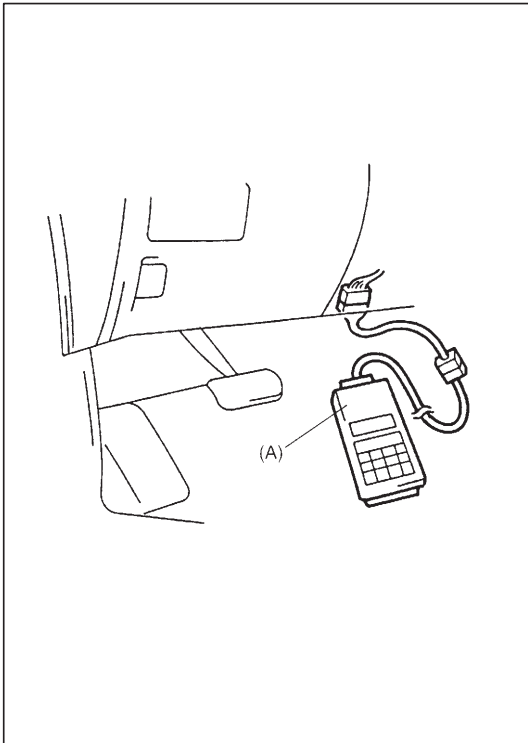

DIAGNOSTIC TROUBLE CODE (DTC) CHECK

- 1) Prepare generic scan tool or SUZUKI scan tool.
- 2) Connect it to data link connector (DLC) located on underside of instrument panel at driver's seat side.

Special Tool

(A): SUZUKI scan tool

- 3) Turn ignition switch ON and confirm that MIL lights.
- 4) Read DTC, pending DTC and freeze frame data according to instructions displayed on scan tool and print them or write them down. Refer to scan tool operator's manual for further details.
If communication between scan tool and ECM (PCM) is not possible, check if scan tool is communicable by connecting it to ECM (PCM) in another car. If communication is possible in this case, scan tool is in good condition. Then check data link connector and serial data line (circuit) in the car with which communication was not possible.
- 5) After completing the check, turn ignition switch off and disconnect scan tool from data link connector.

DIAGNOSTIC TROUBLE CODE (DTC) CLEARANCE

- 1) Connect generic scan tool or SUZUKI scan tool to data link connector in the same manner as when making this connection for DTC check.
- 2) Turn ignition switch OFF and then ON.
- 3) Erase DTC and pending DTC according to instructions displayed on scan tool. Refer to scan tool operator's manual for further details.

NOTE:

- When DTC clear command is executed using Suzuki mode of Suzuki scan tool with engine run, DTC can not be cleared from ECM memory.

- 4) After completing the clearance, turn ignition switch OFF and disconnect scan tool from data link connector.

FAIL-SAFE TABLE

When any of the following DTCs is detected, ECM (PCM) enters fail-safe mode as long as malfunction continues to exist but that mode is canceled when ECM detects normal condition after that.

DTC NO.	TROUBLE AREA	FAIL SAFE OPERATION
P0190 (P0190)	Fuel pressure sensor	Each control is performed based on 150 MPa (1500 bar) fuel pressure.
P0560 (P0560)	Battery voltage	Each control is performed based on 7 volts.
P0121 (P0120)	Throttle position sensor	Each control is performed based on 5% throttle valve opening.
P0221 (P0220)		
P0115 (P0115)	Engine coolant temp sensor	Each control is performed based on 111°C with engine run (–10°C with engine stopped).
P0180	Fuel temp. sensor	Each control is performed based on 90°C.
P0110	Intake air temp. sensor (in mass air flow)	Each control is performed based on 50°C.
P0235 (P0235)	Intake air pressure sensor	Each control is performed based on the value measured by barometric pressure sensor (in ECM). If barometric pressure sensor fails, 900 mbar is used as intake air pressure.
P1101 (P0105)	Barometric pressure sensor (in ECM)	Each control is performed based on the value measured by intake air pressure sensor. If intake air pressure sensor is failed, 900 mbar is used as barometric pressure.
P0100 (P0100)	Mass air flow sensor	Each control uses the value calculated by barometric pressure and engine speed.
P0101 (P100)	Mass air flow sensor	Each control is performed based on 1000 mg/stroke.
P0500 (P0500)	Vehicle speed sensor	Each control is performed based on 20 km/h.

NOTE:

For () marked No. in DTC column, it is indicated when generic scan tool is used.

DIAGNOSTIC TROUBLE CODE (DTC) TABLE

DTC NO.	DETECTING ITEM	DETECTING CONDITION (DTC will set when detecting:)	DTC DRIVING CYCLE	MIL
P0100 (P0100)	Mass air flow sensor circuit malfunction	Sensor output low or high voltage	1 driving cycle	1 driving cycle
P0101 (P0100)	Mass air flow sensor circuit range/performance problem	Air flow is lower or higher than specification under specified engine RPM	1 driving cycle	1 driving cycle
P0110	Intake air temp. sensor circuit malfunction	Intake air temp. sensor circuit low or high input	1 driving cycle	–
P0115 (P0115)	Engine coolant temp. sensor circuit malfunction	Engine coolant temp. sensor circuit low or high input	1 driving cycle (2 driving cycles)	–
P0121 (P0120)	Throttle position sensor circuit range/performance	Throttle position sensor circuit low or high input, or Poor performance of throttle position sensor	1 driving cycle	1 driving cycle
P0221 (P0220)	Throttle position sensor circuit range/performance problem 2			
P0180	Fuel temp. sensor circuit malfunction	Fuel temp. circuit low or high input	1 driving cycle	–
P0190 (P0190)	Fuel rail press sensor circuit malfunction	Fuel rail pressure sensor circuit low or high input	1 driving cycle	1 driving cycle
P0191 (P0230)	Fuel rail press sensor/press regulator consistency function (Fuel pump primary circuit malfunction)	Poor performance of Fuel rail pressure sensor	1 driving cycle	1 driving cycle
☆ P0201 (P0200)	Injector circuit malfunction cyl-1	Monitor signal of fuel injection #1 is different from command signal (circuit open or short), or Poor performance of Fuel Injector #1	1 driving cycle	1 driving cycle
☆ P0202 (P0200)	Injector circuit malfunction cyl-2	Monitor signal of fuel injection #2 is different from command signal (circuit open or short), or Poor performance of Fuel Injector #2	1 driving cycle	1 driving cycle
☆ P0203 (P0200)	Injector circuit malfunction cyl-3	Monitor signal of fuel injection #3 is different from command signal (circuit open or short), or Poor performance of Fuel Injector #3	1 driving cycle	1 driving cycle
☆ P0204 (P0200)	Injector circuit malfunction cyl-4	Monitor signal of fuel injection #4 is different from command signal (circuit open or short), or Poor performance of Fuel Injector #4	1 driving cycle	1 driving cycle
P0215	Double relay circuit malfunction	Poor performance of double relay	1 driving cycle	–
P0230	Fuel pump supply circuit malfunction	Fuel pump supply circuit low or high input, or Poor performance of fuel pump	1 driving cycle	–
P0235 (P0235)	Intake press sensor circuit malfunction	Intake air pressure sensor circuit low or high input, or Poor performance of intake air pressure sensor	1 driving cycle	1 driving cycle
P0243 (P0243)	Turbo press solenoid valve circuit range/performance problem	Monitor signal of Turbo pressure regulator solenoid valve is different from command signal (circuit open or short)	1 driving cycle	–
P0245 (P0243)		Intake air pressure is higher than specification	1 driving cycle	–
P0246 (P0243)		Intake air pressure is lower than specification	1 driving cycle	1 driving cycle

DTC NO.	DETECTING ITEM	DETECTING CONDITION (DTC will set when detecting:)	DTC DRIVING CYCLE	MIL
☆ P0335 (P0335)	Crankshaft position sensor Circuit Malfunction	Monitor signal of crankshaft position sensor is lower or higher than specification	1 driving cycle (2 driving cycles)	—
☆ P0340 (P0335/ P0340)	Camshaft position sensor Circuit Malfunction (Crankshaft position sensor Circuit Malfunction/Camshaft position sensor Circuit Malfunction)	Supply voltage low or high input, or Poor performance of camshaft or crankshaft position sensor	1 driving cycle (2 driving cycles)	—
P0380 (P0380)	Pre/post heat relay circuit malfunction	Both pre/post heating relay and diagnostic signals are high or low level	1 driving cycle (2 driving cycles)	—
P0381	Glow indicator lamp circuit malfunction	Monitor signal of glow indicator lamp circuit is different from command signal (circuit open or short)	1 driving cycle	—
P0403 (P0403)	EGR solenoid valve circuit malfunction	Monitor signal of EGR solenoid valve is different from command signal (circuit open or short)	1 driving cycle (2 driving cycles)	—
P0401 (P0903)	EGR solenoid valve flow insufficient detected	Insufficient EGR flow	1 driving cycle	1 driving cycle
P0402 (P0903)	EGR solenoid valve flow excessive detected	Excessive EGR flow	1 driving cycle (2 driving cycles)	—
P0500 (P0500)	VSS circuit malfunction	Vehicle speed is lower or higher than specification under certain condition	1 driving cycle (2 driving cycles)	—
P0560 (P0560)	Power supply circuit malfunction	Power supply low or high input	1 driving cycle (2 driving cycles)	—
P0561 (P0560)	Stabilization of sensor supply	Poor performance of ECM	1 driving cycle	1 driving cycle
P0603	ECU function (EEPROM error)	Poor performance of ECM	1 driving cycle	—
P0604 (P0120)	Throttle position sensor monitoring system malfunction	Poor performance of throttle position sensor	1 driving cycle	1 driving cycle
☆ P0606	ECU function (internal fault)	Poor performance of ECM	1 driving cycle	—
☆ P1613			1 driving cycle	1 driving cycle
P1101 (P0105)	Barometric press sensor circuit malfunction	Poor performance of ECM	1 driving cycle (2 driving cycles)	—
P1108	Radiator fan high speed circuit malfunction	Monitor signal of radiator relay (high) circuit is different from command signal (circuit open or short)	1 driving cycle	—
P1109	Radiator fan low speed circuit malfunction	Monitor signal of radiator relay (low) circuit is different from command signal (circuit open or short)	1 driving cycle	—

DTC NO.	DETECTING ITEM	DETECTING CONDITION (DTC will set when detecting:)	DTC DRIVING CYCLE	MIL
P1110	A/C cut signal circuit malfunction	Monitor signal of A/C cut signal circuit is different from command signal (circuit open or short)	1 driving cycle	–
☆ P1112 (P0230)	Fuel rail pressure monitoring circuit malfunction (Fuel pump primary circuit malfunction)	Fuel pressure in common rail is lower or higher than specification	1 driving cycle	1 driving cycle
P1138 (P0230)	Fuel press regulator circuit malfunction	Monitor signal of fuel pressure regulator is different from command signal (circuit open or short), or poor performance of regulator	1 driving cycle	1 driving cycle
☆ P1169 (P0170)	Condenser voltage function 1 (Fuel trim malfunction)	Poor performance of ECM	1 driving cycle	1 driving cycle
☆ P1170 (P0170)	Condenser voltage function 2 (Fuel trim malfunction)	Poor performance of ECM	1 driving cycle	1 driving cycle
P1171	ECU function (ECU internal fault)	Poor performance of ECM	1 driving cycle	–
P1402 (P0510)	Throttle solenoid valve circuit malfunction	Monitor signal of EGR throttle solenoid valve is different from command signal (circuit open or short), or poor performance of valve	1 driving cycle (2 driving cycles)	–
P1404 (P0380)	TL4226 circuit function (pre post heating relay command malfunction)	Monitor signal of pre post heating relay is different from command signal	1 driving cycle (2 driving cycles)	–
P1511	Ignition switch circuit malfunction	Ignition signal is not memorized in ECM	1 driving cycle	–
△ P1517	Immobilizer system malfunction	–	–	–
P1519	Radiator fan circuit malfunction	Radiator fan relay signal is not corresponding to radiator fan state signal	1 driving cycle	–
P1135	3 rd piston deactivator (injection pump solenoid valve) circuit malfunction	Monitor signal of injection pump solenoid valve is different from command signal (circuit open or short)	1 driving cycle	–
P1606	MIL circuit malfunction	Monitor signal of MIL circuit is different from command signal (circuit open or short)	1 driving	–
P1608	Engine coolant temp. warning lamp circuit malfunction	Monitor signal of engine coolant temp. warning lamp circuit is different from command signal (circuit open or short)	1 driving	–
P1614 (P0560)	Sensor supply function	Sensor power supply low or high voltage	1 driving cycle (2 driving cycles)	–

NOTE:

- For “☆” marked No. in DTC column, engine is hard to start unless DTC is cleared from ECM memory.
- For () marked No. in DTC column, it is indicated when generic scan tool is used.
- DTC DRIVING CYCLE column indicates the number of driving cycle before DTC is stored in ECM memory.
- For () marked item in DTC DRIVING CYCLE column, it is the number of driving cycle used for generic scan tool.
- For “△” marked No. in DTC column, ignore this DTC though it may be indicated on Suzuki scan tool. It dose not affect engine and emission control system.

VISUAL INSPECTION

Visually check following parts and systems.

INSPECTION ITEM	REFERRING SECTION
<ul style="list-style-type: none"> ● Engine oil ----- level, leakage ● Engine coolant ----- level, leakage ● Fuel ----- level, leakage ● A/T fluid ----- level, leakage ● Air cleaner element ----- dirt, clogging ● Battery ----- fluid level, corrosion of terminal ● Drive belt ----- tension, damage ● Accelerator cable ----- play (after warm up engine), installation ● Vacuum hoses of air intake system ----- disconnection, looseness, deterioration, bend ● Connectors of electric wire harness --- disconnection, friction ● Fuses ----- burning ● Parts ----- installation, bolt ----- looseness ● Parts ----- deformation ● Other parts that can be checked visually 	<p>Section 0B Section 0B Section 0B Section 0B Section 0B Section 0B Section 6E3</p>
<p>Also add following items at engine start, if possible.</p> <ul style="list-style-type: none"> ● Malfunction indicator lamp ● Charge warning lamp ● Engine oil pressure warning lamp ● Engine coolant temp. warning lamp ● Engine coolant temp. meter ● Fuel level meter ● Abnormal air being inhaled from air intake system ● Exhaust system ----- leakage of exhaust gas, noise ● Other parts that can be checked visually 	<p>Section 8 Section 6 Section 6H Section 8 Section 8 Section 8 Section 8</p>

ENGINE BASIC CHECK

This check is very important for troubleshooting when ECM (PCM) has detected no DTC and no abnormality has been found in visual inspection.

Follow the flow table carefully.

STEP	ACTION	YES	NO
1	Was "ENGINE DIAG. FLOW TABLE" performed?	Go to Step 2.	Go to "ENGINE DIAG. FLOW TABLE".
2	Check battery voltage. Is it 11 V or more?	Go to Step 3.	Charge or replace battery.
3	Is engine cranked?	Go to Step 4.	Go to "DIAGNOSIS" in Section 6G or 6G1.
4	Does engine start?	Go to Step 5.	Go to Step 6.
5	Check engine idle speed referring to "Idle speed Inspection" in Section 6E3. Is check result as specified?	Go to Step 11 in "ENGINE DIAG. FLOW TABLE".	Go to "Engine Diagnosis Table" in this section.
6	Is immobilizer control system equipped?	<ul style="list-style-type: none"> ● Go to step 7 if Suzuki scan tool is available. ● Go to "DIAGNOSIS" in Section 8G if Suzuki scan tool is not available. 	Go to Step 8.
7	Check immobilizer system malfunction as follows. 1) Execute Data List mode of Suzuki mode using ECM application of Suzuki scan tool. Dose Suzuki scan tool indicate communication error message?	Go to "DIAGNOSIS" in Section 8G.	Go to Step 8.
8	Check fuel supply as follows: 1) Check to make sure that enough fuel is filled in fuel tank. 2) Turn ON ignition switch for 5 seconds and then OFF. Repeat this a few times. Is fuel return pressure (returning sounds) felt from fuel return hose when ignition switch is turned ON?	Go to Step 10.	Go to Step 9.
9	Check fuel pump for operating. 1) Was fuel pump operating sound heard from fuel pump for about 5 seconds after ignition switch ON and stop?	Go to "LOW PRESSURE FUEL SUPPLY INSPECTION" in Section 6E3.	Go to "Diag. Flow Table B-1".
10	Check fuel injector referring to "Fuel Injector Inspection" in Section 6E3. Is it in good condition?	Go to "Engine Diagnosis Table" in this section.	Go to "DTC P0201/0202/0203/0204 Flow Table".

ENGINE DIAGNOSIS TABLE

Perform troubleshooting referring to following table when ECM (PCM) has detected no DTC and no abnormality has been found in visual inspection and engine basic inspection previously.

Condition	Possible Cause	Reference Item
Hard starting (Engine cranks OK)	<p>Fuel system out of order.</p> <ul style="list-style-type: none"> ● Lack of fuel in fuel tank ● Fuel filter <ul style="list-style-type: none"> – Dirty or clogged – Water mixed in ● Dirty or clogged fuel hose or pipe ● Fuel injection pipe <ul style="list-style-type: none"> – Cracks – Fuel leakage from joints ● Clogged fuel injector ● Faulty fuel pump <p>Engine and emission control system out of order.</p> <ul style="list-style-type: none"> ● Faulty ECM ● Faulty fuel pressure sensor ● Faulty CKP sensor (Engine speed sensor) ● Faulty CMP sensor ● Faulty fuel injection pump <ul style="list-style-type: none"> – Air mixed in – Pump internal damage – Faulty fuel pressure regulator ● Faulty fuel injector ● Faulty ECT sensor <p>Glow system out of order.</p> <ul style="list-style-type: none"> ● Faulty glow plug ● Faulty pre post heating relay <p>Low compression.</p> <ul style="list-style-type: none"> ● Compression leak from valve seat ● Sticky valve stem ● Weak or damaged valve springs ● Compression leak at cylinder head gasket ● Sticking or damaged piston ring ● Worn piston, ring or cylinder <p>Immobilizer control system out of order.</p> <p>Others</p> <ul style="list-style-type: none"> ● Broken valve timing belt ● Faulty EGR throttle valve 	<p>Refill.</p> <p>Replace. Repair. Clean.</p> <p>Replace. Correct. Replace. Inspect and replace.</p> <p>Replace. Inspect and replace. Inspect and replace. Inspect, adjust and replace.</p> <p>Refill fuel in fuel tank. Replace. Inspect and replace. Inspect and replace. Inspect and replace.</p> <p>Inspect and replace. Inspect and replace.</p> <p>Remove cylinder head and lap valves. Correct or replace valve. Replace valve springs. Repair or replace.</p> <p>Replace piston rings. Replace ring and piston. Rebore or replace cylinder. Refer to Section 8G.</p> <p>Replace timing belt and repair valve train. Inspect and replace.</p>

Condition	Possible Cause	Reference Item
Improper engine idling or engine fails to idle	<p>Intake system out of order.</p> <ul style="list-style-type: none"> ● Clogged air cleaner element ● EGR throttle valve <p>Fuel system out of order.</p> <ul style="list-style-type: none"> ● Shortage of fuel in fuel tank ● Fuel filter <ul style="list-style-type: none"> – Dirty or clogged – Water mixed in ● Dirty or clogged fuel hose or pipe ● Fuel injection pipe <ul style="list-style-type: none"> – Cracks – Fuel leakage from joints ● Clogged fuel injector <ul style="list-style-type: none"> Faulty fuel pump <p>Engine overheating.</p> <p>Engine and emission control system out of order.</p> <ul style="list-style-type: none"> ● Faulty ECM ● Faulty mass air flow sensor ● Faulty fuel injector ● Faulty fuel injection pump <ul style="list-style-type: none"> – Faulty injection pump solenoid valve (3rd piston deactivator) – Air mixed in – Pump internal damage – Faulty fuel pressure regulator – Faulty fuel pressure sensor – Faulty TP sensor (accelerator stroke sensor) ● Faulty VSS ● Faulty CKP sensor ● Faulty ECT sensor <p>Glow system out of order.</p> <ul style="list-style-type: none"> ● Faulty glow plug ● Faulty pre post heating relay <p>EGR system out of order.</p> <ul style="list-style-type: none"> ● Faulty EGR solenoid valve ● Faulty EGR valve <p>Low compression.</p> <p>Others</p> <ul style="list-style-type: none"> ● Faulty A/T shift switch ● Faulty A/C signal ● Mal-adjusted accelerator cable 	<p>Clean or replace. Inspect and replace.</p> <p>Refill.</p> <p>Replace. Repair. Clean.</p> <p>Replace. Repair. Replace. Inspect and replace. Refer to “Overheating” section.</p> <p>Replace. Inspect and replace. Inspect and replace.</p> <p>Inspect and replace.</p> <p>Refill fuel in fuel tank. Replace. Inspect and replace. Inspect and replace. Inspect and replace.</p> <p>Inspect and replace. Inspect and replace. Inspect and replace.</p> <p>Inspect and replace. Inspect and replace.</p> <p>Inspect and repair or replace EGR system. Inspect and repair or replace EGR system. Previously outlined.</p> <p>Inspect and replace. Inspect and replace. Adjust.</p>

Condition	Possible Cause	Reference Item
Abnormal knocking	<p>Fuel system out of order.</p> <ul style="list-style-type: none"> ● Fuel injection pipe <ul style="list-style-type: none"> – Cracks – Fuel leakage from joints ● Faulty fuel injector <ul style="list-style-type: none"> – Incorrect valve opening pressure – Seized needle valve – Improperly installed nozzle holder – Faulty nozzle gasket <p>Engine and emission control system out of order.</p> <ul style="list-style-type: none"> ● Faulty ECM ● Faulty fuel injection pump <ul style="list-style-type: none"> – Faulty fuel pressure regulator – Faulty timer control valve ● Faulty fuel temp. sensor ● Faulty ECT sensor <p>Other</p> <ul style="list-style-type: none"> ● Faulty EGR valve 	<p>Replace. Repair. Inspect and replace. Adjust. Replace. Repair. Replace.</p> <p>Replace. Inspect and replace. Inspect and replace. Inspect and replace. Inspect and replace. Inspect and replace.</p> <p>Inspect and replace.</p>
Engine hesitates when accelerating	<p>Intake system out of order.</p> <ul style="list-style-type: none"> ● Clogged air cleaner element ● Faulty turbocharger. <p>Fuel system out of order.</p> <ul style="list-style-type: none"> ● Fuel filter <ul style="list-style-type: none"> – Dirty or clogged – Water mixed in ● Dirty or clogged fuel hose or pipe ● Fuel injection pipe <ul style="list-style-type: none"> – Cracks – Fuel leakage from joints ● Clogged fuel injector <p>Engine overheating.</p> <p>Engine and emission control system out of order.</p> <ul style="list-style-type: none"> ● Faulty ECM ● Faulty fuel injection pump <ul style="list-style-type: none"> – Faulty fuel pressure regulator – Air mixed in – Pump internal damage – Faulty injection pump solenoid valve (3rd piston deactivator) – Faulty MAF sensor ● Faulty TP sensor (Accelerator stroke sensor) ● Faulty intake air pressure sensor ● Faulty CKP sensor ● Faulty ECT sensor ● Faulty IAT sensor <p>EGR system out of order.</p> <ul style="list-style-type: none"> ● Faulty EGR solenoid valve ● Faulty EGR valve <p>Low compression.</p> <p>Other</p> <ul style="list-style-type: none"> ● Mal-adjusted accelerator cable 	<p>Clean or replace. Replace.</p> <p>Replace. Repair. Clean or replace.</p> <p>Replace. Repair. Inspect and replace. Refer to “Overheating” section.</p> <p>Inspect and replace.</p> <p>Adjust. Refill fuel in fuel tank. Inspect and replace. Inspect and replace.</p> <p>Inspect and replace. Inspect and replace.</p> <p>Inspect and replace. Inspect and replace. Inspect and replace. Inspect and replace.</p> <p>Inspect and repair or replace EGR system. Inspect and repair or replace EGR system.</p> <p>Previously outlined.</p> <p>Replace.</p>

Condition	Possible Cause	Reference Item
Overheating	<ul style="list-style-type: none"> ● Insufficient coolant ● Loose water pump belt ● Inoperative thermostat ● Poor water pump performance ● Clogged or leaky radiator ● Improper engine oil grade ● Clogged oil filter or oil strainer ● Not enough oil ● Poor oil pump performance ● Oil leakage ● Dragging brakes ● Slipping clutch ● Blown cylinder head gasket 	<ul style="list-style-type: none"> Replenish. Adjust. Replace. Replace. Flush, repair or replace. Replace with proper grade oil. Replace or clean (oil strainer). Replenish. Repair or replace. Repair. Repair or replace. Repair or replace. Replace.
Excessive engine oil consumption	<p>Oil leakage</p> <ul style="list-style-type: none"> ● Loose oil drain plug ● Loose oil pan bolts ● Deteriorated or broken oil pan sealant ● Leaky crankshaft oil seal ● Leaky cylinder head cover gasket ● Improper tightening of oil filter ● Loose oil pressure switch ● Blown cylinder head gasket ● Leaky crankshaft pulley oil seal <p>Oil entering combustion chamber</p> <ul style="list-style-type: none"> ● Sticky piston ring ● Worn piston and cylinder ● Worn piston ring groove and ring ● Improper location of piston ring gap ● Worn or damaged valve stem seal ● Worn valve stem 	<ul style="list-style-type: none"> Tighten. Tighten. Replace sealant. Replace. Replace. Tighten. Tighten. Replace. Replace. <p>Remove carbon and replace rings. Replace or rebore cylinder, and replace piston. Replace piston and ring. Reposition ring gap. Replace. Replace.</p>
Low oil pressure	<ul style="list-style-type: none"> ● Improper oil viscosity ● Malfunctioning oil pressure switch ● Not enough oil ● Clogged oil strainer ● Functional deterioration of oil pump ● Worn oil pump relief valve ● Excessive clearance in various sliding parts 	<ul style="list-style-type: none"> Use oil of proper viscosity. Replace. Replenish. Clean. Replace. Replace. Replace worn parts.

Condition	Possible Cause	Reference Item
<p>Engine noise Note: Before checking the mechanical noise, make sure that:</p> <ul style="list-style-type: none"> ● Injection timing is properly adjusted. ● Specified fuel is used. 	<p>Valve noise.</p> <ul style="list-style-type: none"> ● Improper valve lash ● Worn valve stem and guide ● Weak or broken valve spring ● Warped or bent valve <p>Piston, ring and cylinder noise.</p> <ul style="list-style-type: none"> ● Worn piston, ring and cylinder bore <p>Connecting rod noise.</p> <ul style="list-style-type: none"> ● Worn crankpin bearing ● Worn crankpin <ul style="list-style-type: none"> ● Loose connecting rod nuts <p>Low oil pressure.</p> <p>Crankshaft noise.</p> <ul style="list-style-type: none"> ● Worn crankshaft journal bearing ● Worn crankshaft journal <ul style="list-style-type: none"> ● Loose lower crankcase (bearing cap) bolts ● Excessive crankshaft thrust play <p>Engine and emission control system out of order.</p>	<p>Adjust. Replace. Replace. Replace.</p> <p>Rebore or replace cylinder. Replace piston and ring.</p> <p>Replace. Repair by grinding or replace crankshaft. Tighten nuts to specification. Previously outlined.</p> <p>Replace. Repair by grinding or replace crankshaft. Tighten bolts to specification.</p> <p>Replace thrust bearing. Refer to Section 6E3.</p>
<p>White or blue smoke</p>	<p>Intake system out of order.</p> <ul style="list-style-type: none"> ● Clogged air cleaner element ● EGR throttle valve <p>Engine and emission control system out of order.</p> <ul style="list-style-type: none"> ● Faulty ECM ● Faulty fuel injection pump <ul style="list-style-type: none"> – Pump internal damage – Fuel injector ● Faulty intake air pressure sensor ● Faulty ECT sensor <p>Glow system out of order.</p> <ul style="list-style-type: none"> ● Faulty glow plug ● Faulty pre post heating relay <p>Low compression</p> <p>Other</p> <ul style="list-style-type: none"> ● Improper oil level 	<p>Clean or replace. Inspect and replace.</p> <p>Inspect and replace.</p> <p>Replace. Inspect and replace. Inspect and replace. Inspect and replace.</p> <p>Inspect and replace. Inspect and replace. Previously outlined.</p> <p>Adjust.</p>
<p>Black smoke</p>	<p>Intake system out of order.</p> <ul style="list-style-type: none"> ● Faulty turbocharger ● Clogged air cleaner element ● EGR throttle valve <p>Engine and emission control system out of order.</p> <ul style="list-style-type: none"> ● Faulty ECM ● Faulty fuel injector ● Faulty fuel injection pump <ul style="list-style-type: none"> – Faulty fuel pressure regulator – Pump internal damage ● Faulty MAF sensor ● Faulty IAT sensor ● Faulty ECT sensor ● Faulty TP sensor <p>EGR system out of order.</p> <ul style="list-style-type: none"> ● Faulty EGR solenoid valve ● Faulty EGR valve <p>Low compression</p>	<p>Inspect and replace. Clean or replace. Inspect and replace.</p> <p>Inspect and replace. Inspect and replace.</p> <p>Inspect and replace. Replace. Inspect and replace. Inspect and replace. Inspect and replace. Inspect and replace.</p> <p>Inspect and repair or replace EGR system. Inspect and repair or replace EGR system. Previously outlined.</p>

INSPECTION OF PCM (ECM) AND ITS CIRCUITS

PCM (ECM) and its circuits can be checked at PCM (ECM) wiring couplers by measuring voltage and resistance.

CAUTION:

PCM/ECM cannot be checked by itself. It is strictly prohibited to connect voltmeter or ohmmeter to PCM (ECM) with couplers disconnected from it.

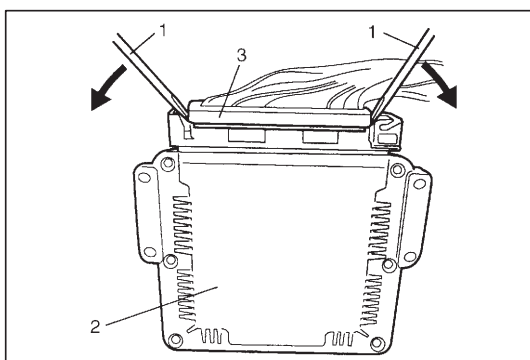
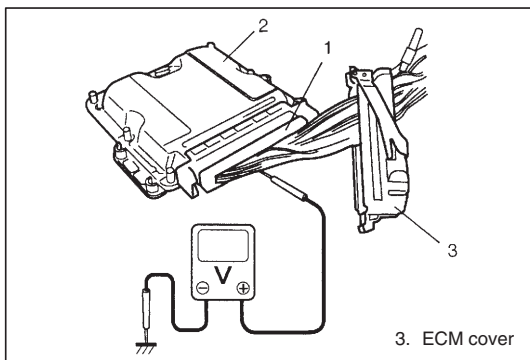
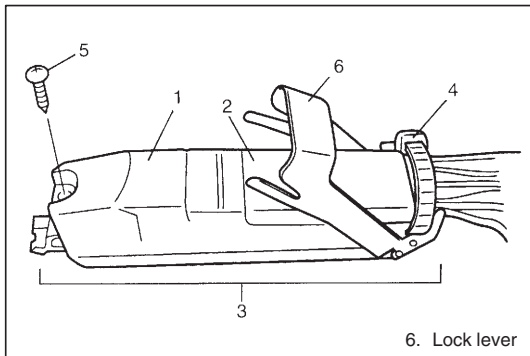

Voltage Check

- 1) Disconnect ECM from bracket referring to "ENGINE CONTROL MODULE" in this section.
- 2) Remove harness cover (2) from ECM connector assembly (3) by removing clamp (4).
- 3) Remove ECM cover (1) from ECM connector after loosening screw (5).

- 4) Measure voltage at each terminal with ignition switch turned on according to Diag. Flow Table after connecting ECM connector (1) to ECM (2) securely.

NOTE:

As each terminal voltage is affected by the battery voltage, confirm that it is 11 V or more when ignition switch is ON.

- 5) After measuring, disconnect ECM connector (3) from ECM (2) using two screwdrivers (1) as shown in figure.

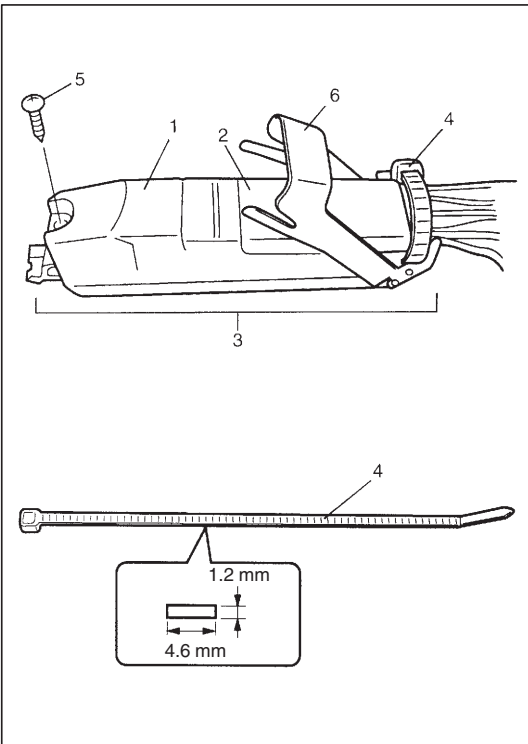

- 6) Install ECM cover (1) to ECM connector and tighten screw (5).
- 7) Install harness cover (2) to ECM connector assembly (3) by fastening clamp (4) and then lock ECM connector using lock lever (6).

NOTE:

When clamp replacement is necessary, be sure to use a clamp with width and thickness as specified below or less. If a larger clamp is used, lock lever will be caught by clamp and it will be impossible to install ECM connector to ECM.

Width: 4.6 mm Thickness: 1.2 mm

- 8) Install ECM to bracket referring to "ENGINE CONTROL MODULE" in this section.

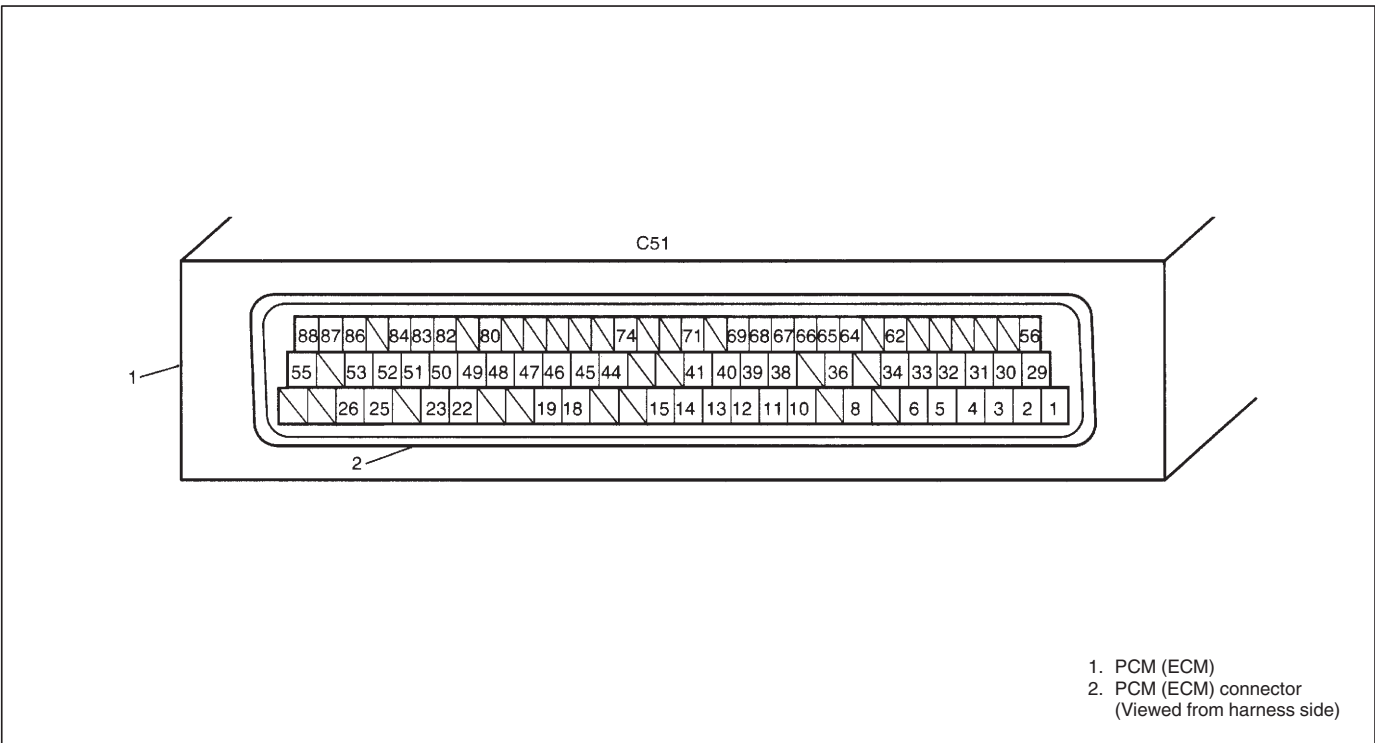

1. PCM (ECM)
2. PCM (ECM) connector
(Viewed from harness side)

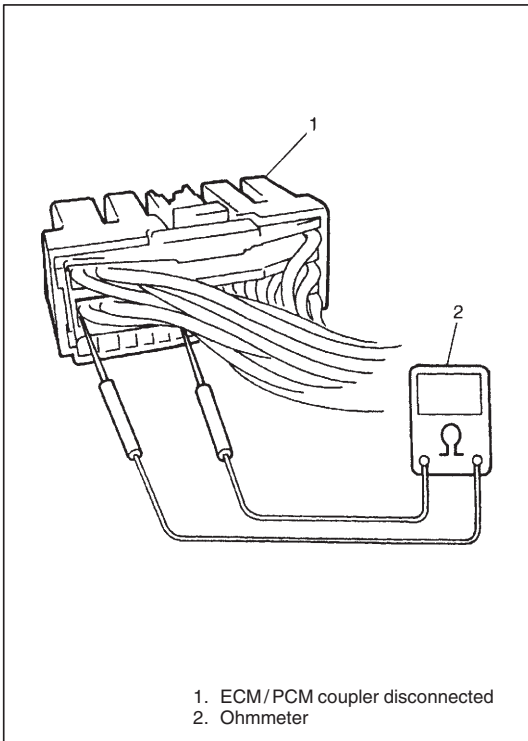

Resistance Check

1) Disconnect couplers from ECM/PCM with ignition switch OFF.

CAUTION:

Never touch terminals of ECM/PCM itself or connect voltmeter or ohmmeter.

2) Check resistance between each pair of terminals of disconnected couplers as listed in the following table.

CAUTION:

- Be sure to connect ohmmeter probe from wire harness side of coupler.
- Be sure to turn OFF ignition switch for this check.
- Resistance in table represents that when parts temperature is 20°C (68°F).

TERMINAL	CIRCUIT	STANDARD RESISTANCE	CONDITION
C51-2 to C51-30	Fuel injector No.1	Max. 0.6 Ω	—
C51-5 to C51-6	Fuel injector No.2	Max. 0.6 Ω	—
C51-3 to C51-31	Fuel injector No.3	Max. 0.6 Ω	—
C51-4 to C51-32	Fuel injector No.4	Max. 0.6 Ω	—
C51-14 to C51-41	CKP sensor	315 – 405 Ω	At 20°C (68°F)
C51-22 to C51-39	Fuel temp. sensor	Refer to "FUEL TEMPERATURE SENSOR" in Section SE3.	
C51-29 to C51-50	Fuel pressure regulator	2 – 3 Ω	At 20°C (68°F)
C51-45 to C51-46	ECT sensor	Refer to "ECT SENSOR" in Section 6E3.	
C51-33 to Body ground	Ground	Continuity	—
C51-49 to Body ground	Ground	Continuity	—
C51-51 to Body ground	Ground	Continuity	—
C51-53 to Body ground	Ground	Continuity	—

TABLE A-1 MALFUNCTION INDICATOR LAMP CIRCUIT CHECK – MIL DOES NOT COME “ON” OR DIMS AT IGNITION SWITCH ON (BUT ENGINE AT STOP)

WIRING DIAGRAM

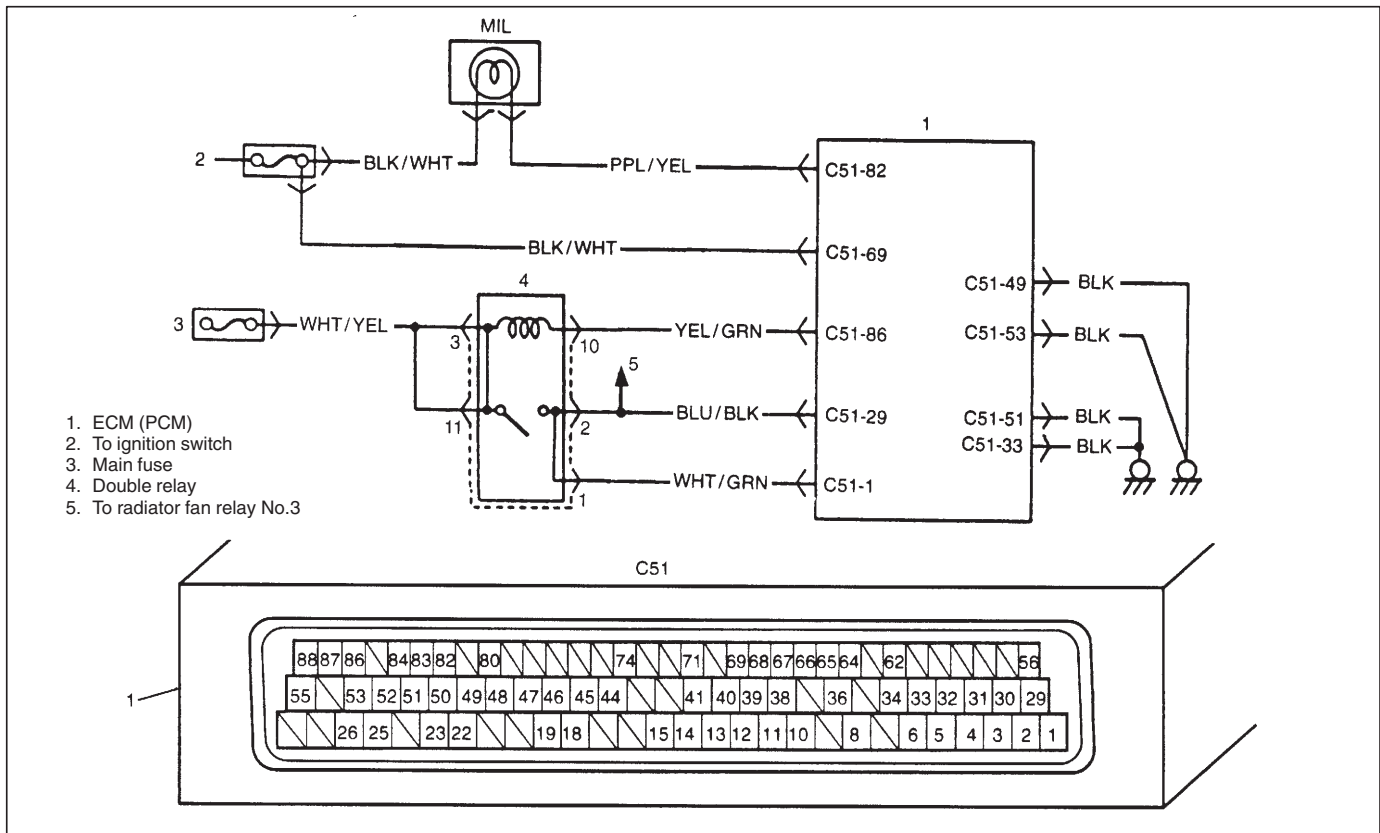

CIRCUIT DESCRIPTION

When the ignition switch is turned ON, ECM causes the main relay to turn ON (close the contact point). Then, ECM being supplied with the main power, turns ON the malfunction indicator lamp (MIL). When the engine starts to run and no malfunction is detected in the system, MIL goes OFF but if a malfunction was or is detected, MIL remains ON even when the engine is running.

INSPECTION

STEP	ACTION	YES	NO
1	MIL Power Supply Check: 1) Turn ignition switch ON. Do other indicator/warning lights in combination meter comes ON?	Go to Step 2.	“IG” fuse blown, main fuse blown, Ignition switch malfunction, “BLK/WHT” circuit between “IG” fuse and combination meter or poor coupler connection at combination meter.
2	ECM Power and Ground Circuit Check: Does engine start?	Go to Step 3.	Go to TABLE A-3 ECM (PCM) POWER AND GROUND CIRCUIT CHECK. If engine is not cranked, go to DIAGNOSIS in Section 6G or 6G1.
3	MIL Circuit Check: 1) Turn ignition switch OFF and disconnect connectors from ECM. 2) Check for proper connection to ECM at terminal C51-82. 3) If OK, then using service wire, ground terminal C51-82 in connector disconnected. Does MIL turn on at ignition switch ON?	Substitute a known-good ECM (PCM) and recheck.	Bulb burned out or “PPL/YEL” wire circuit open.

TABLE A-2 MALFUNCTION INDICATOR LAMP CIRCUIT CHECK – MIL REMAINS “ON” AFTER ENGINE STARTS

WIRING DIAGRAM/CIRCUIT DESCRIPTION

Refer to TABLE A-1.

INSPECTION

STEP	ACTION	YES	NO
1	DTC Check. 1) With ignition switch OFF, install scan tool. 2) Start engine and check DTC. Is there any DTC(s).	Go to Step 2 of “ENGINE DIAG. FLOW TABLE” in this section.	Go to Step 2.
2	MIL circuit Check: (1) With ignition switch OFF, disconnect couplers from ECM (PCM). Does MIL turn ON at ignition switch ON?	“PPL/YEL” wire shorted to ground circuit.	Substitute a known-good ECM (PCM) and recheck.

TABLE A-3 ECM (PCM) POWER AND GROUND CIRCUIT CHECK – MIL DOESN’T LIGHT AT IGNITION SWITCH ON AND ENGINE DOESN’T START THOUGH IT IS CRANKED UP.

WIRING DIAGRAM

Refer to TABLE A-1.

CIRCUIT DESCRIPTION

When the ignition switch is turned ON, the double relay turns ON (the contact point closes) and the main power is supplied to ECM (PCM).

TABLE A-3
INSPECTION

STEP	ACTION	YES	NO
1	Double Relay Operating Sound Check: Is operating sound of double relay heard at ignition switch ON?	Go to Step 5.	Go to Step 2.
2	Fuse Check: Is main "FI" fuse in good condition?	Go to Step 3.	Check for short in circuits connected to this fuse.
3	Double Relay Check: 1) Turn OFF ignition switch and remove double relay. 2) Check for proper connection to double relay at terminal 3 and 10. 3) If OK, check double relay referring to "Double Relay Inspection" in Section 6E3. Is check result satisfactory?	Go to Step 4.	Replace main relay.
4	ECM (PCM) Power Circuit Check: 1) Turn OFF ignition switch, disconnect connectors from ECM (PCM) and install main relay. 2) Check for proper connection to ECM (PCM) at terminals C51-69, C51-86, C51-29 and C51-1. 3) If OK, then measure voltage between terminal C51-69 and ground, C51-86 and ground with ignition switch ON. Is each voltage 10 – 14 V?	Go to Step 5.	"BLK/WHT", "YEL/GRN" or "WHT/YEL" circuit open.
5	ECM Power Circuit Check: 1) Using service wire, ground terminal C51-86 and measure voltage between terminal C51-29 and ground, C51-1 and ground at ignition switch ON. Is it 10 – 14 V?	Check ground circuits "BLK" for open. If OK, then substitute a known-good ECM (PCM) and recheck.	Go to Step 6.
6	Is operating sound of double relay heard in Step 1?	Go to Step 7.	"WHT/YEL" or "BLU/BLK" wire open
7	Double Relay Check: 1) Check double relay according to procedure in Step 3. Is main relay in good condition?	"WHT/YEL" or "BLU/BLK" wire open.	Replace double relay.

DTC P0100 (DTC P0100) MASS AIR FLOW CIRCUIT MALFUNCTION WIRING DIAGRAM

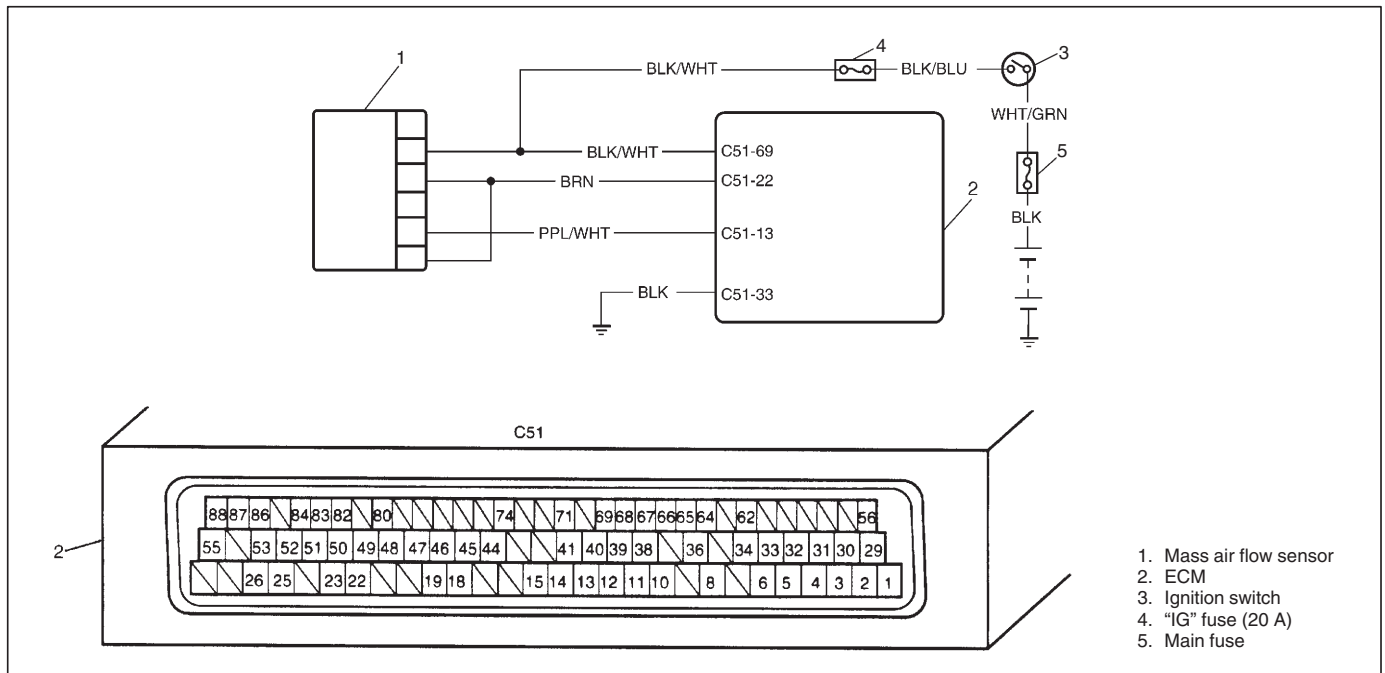

DTC CONFIRMATION PROCEDURE

NOTE:

Check to make sure that the following conditions are satisfied when using this DTC CONFIRMATION PROCEDURE.

- Intake air temp.: -8°C, 18°F or higher
- Engine coolant temp.: -8 – 110°C (18 – 230°F)
- Altitude (barometric pressure): 2400 m, 8000 ft or less (560 mmHg, 75 kPa or more)

- 1) Connect scan tool to DLC with ignition switch OFF.
- 2) Turn ON ignition switch and clear DTC, pending DTC and freeze frame data by using scan tool and run engine at idle speed.
- 3) Check DTC and pending DTC by using scan tool.

TROUBLESHOOTING

STEP	ACTION	YES	NO
1	Was "ENGINE DIAG. FLOW TABLE" performed?	Go to Step 2.	Go to "ENGINE DIAG. FLOW TABLE".
2	MAF sensor power supply Check: 1) With ignition switch OFF, disconnect MAF sensor coupler. 2) With ignition switch ON, check voltage between "BLK/WHT" wire terminal of MAF sensor coupler and ground. Is voltage 10 – 14 V?	Go to Step 3.	Faulty "BLK/WHT" wire.
3	MAF sensor output voltage Check: 1) With ignition switch OFF, connect MAF sensor coupler. 2) Remove ECM (PCM) cover. 3) Start engine and check voltage between C51-13 and C51-33 terminal at idle speed. Is voltage about 2 V?	Poor C51-13 connection, Faulty "BRN" wire and Poor C51-22 connection. If OK, substitute a known-good ECM and recheck. (See NOTE)	Faulty "PPL/WHT" wire. Poor MAF sensor coupler terminal connection. If wire and connection are OK, substitute a known-good MAF sensor and recheck.

NOTE:

If DTC is checked using generic scan tool only and DTC P0101 (P0100) Diag. Flow Table is not performed yet, go to the table before ECM replacement.

DTC P0101 (P0100) MAF SENSOR CIRCUIT RANGE/PERFORMANCE PROBLEM**WIRING DIAGRAM**

Refer to DTC P0100.

DTC CONFIRMATION PROCEDURE**NOTE:**

Check to make sure that the following conditions are satisfied when using this DTC CONFIRMATION PROCEDURE.

- Intake air temp.: -8°C , 18°F or higher
- Engine coolant temp.: $-8 - 110^{\circ}\text{C}$ ($18 - 230^{\circ}\text{F}$)
- Altitude (barometric pressure): 2400 m, 8000 ft or less (560 mmHg, 75 kPa or more)

- 1) Connect scan tool to DLC with ignition switch OFF.
- 2) Turn ON ignition switch and clear DTC, pending DTC and freeze frame data by using scan tool and run engine at idle speed for 10 sec. or more.
- 3) Then run engine over 3000 rpm for 10 sec. or more.
- 4) Check DTC and pending DTC.

TROUBLESHOOTING

STEP	ACTION	YES	NO
1	Was "ENGINE DIAG. FLOW TABLE" performed?	Go to Step 2.	Go to "ENGINE DIAG. FLOW TABLE".
2	1) Remove ECM (PCM) cover referring to "Voltage Check" in this section. 2) Start engine and check voltage between C51-13 and C51-33 terminals. Engine speed at 3000 rpm: about 3.1 V Engine speed at idling: about 2 V Is each value satisfied?	Intermittent trouble or faulty ECM. Check for intermittent referring to "Intermittent and Poor Connection" in Section 0A. (See NOTE.)	Clogged or leaky air intake system. If all are OK, substitute a known-good MAF sensor and recheck.

NOTE:

If DTC is checked using generic scan tool only and DTC P0100 (P0100) Diag. Flow Table is not performed yet, go to the table before ECM replacement.

DTC P0110 INTAKE AIR TEMP. (IAT) CIRCUIT MALFUNCTION WIRING DIAGRAM

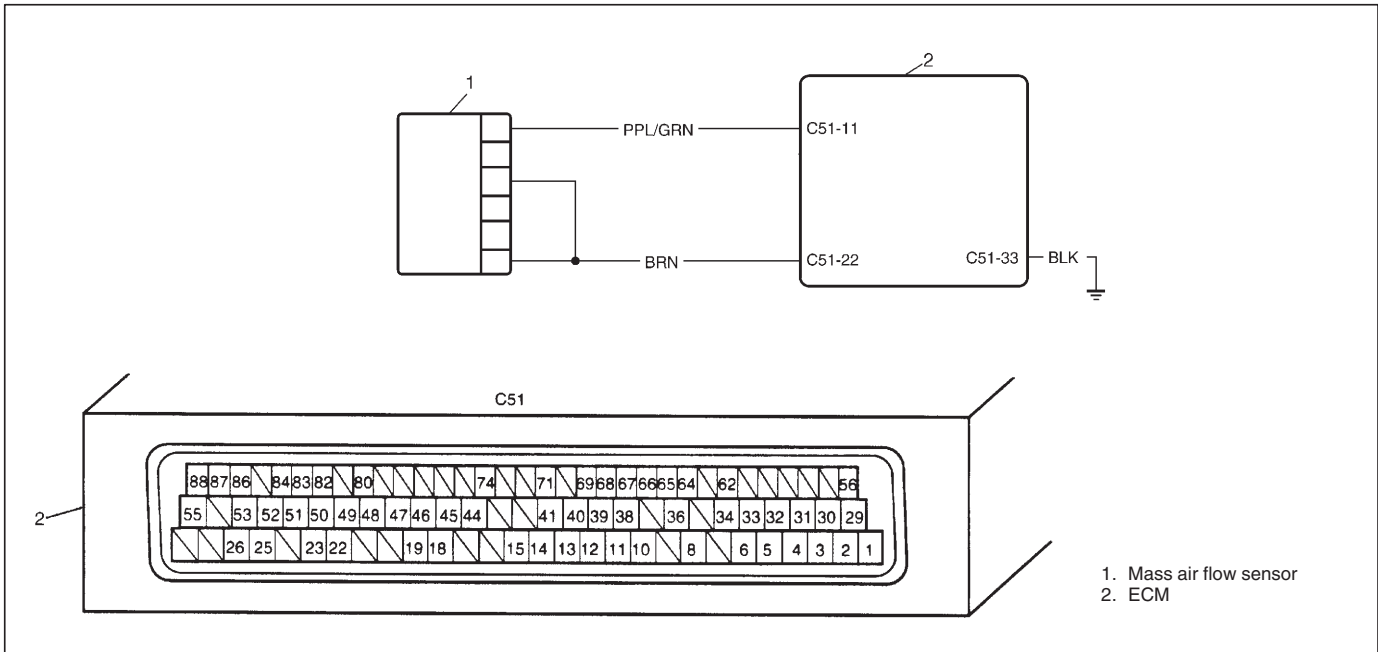

DTC CONFIRMATION PROCEDURE

- 1) Connect scan tool to DLC with ignition switch OFF.
- 2) Turn ON ignition switch and clear DTC, pending DTC and freeze frame data by using scan tool.
- 3) Turn OFF ignition switch, then ON.
- 4) Check DTC and pending DTC by using scan tool.

TROUBLESHOOTING

STEP	ACTION	YES	NO
1	Was "ENGINE DIAG. FLOW TABLE" performed?	Go to Step 2.	Go to "ENGINE DIAG. FLOW TABLE".
2	Check IAT Sensor and Its Circuit. 1) Connect scan tool with ignition switch OFF. 2) Turn ignition switch ON. 3) Check intake air temp. displayed on scan tool. Is -40°C (-40°F) or 131°C (268°F) indicated?	Go to Step 3.	Intermittent trouble. Check for intermittent referring to "Intermittent and Poor Connection" in Section 0A.
3	Check Wire Harness. 1) Disconnect MAF sensor (built-in IAT sensor) connector with ignition switch OFF. 2) Check for proper connection to MAF sensor (built-in IAT sensor) at "PPL/GRN" and "BRN" wire terminals. 3) If OK, then with ignition switch ON, is voltage applied to "PPL/GRN" wire terminal of harness side about 5 V?	Go to Step 4.	"PPL/GRN" wire open or shorted to power, or poor C51-11 connection. If wire and connection are OK, substitute a known-good ECM and recheck.
4	Does scan tool indicate -40°C (-40°F) at Step 2?	Go to Step 6.	Go to Step 5.
5	Check Wire Harness. 1) Disconnect MAF sensor connector. 2) Check intake air temp. displayed on scan tool. Is -40°C (-40°F) indicated?	Replace MAP sensor.	"PPL/GRN" wire shorted to ground. If wire is OK, substitute a known-good ECM and recheck.
6	Check Wire Harness. 1) Using service wire, connect MAF sensor (built-in IAT sensor) connector terminals. (between "PPL/GRN" wire terminal and "BRN" wire terminal of harness side) 2) Turn ignition switch ON and check intake air temp. displayed on scan tool. Is 131°C (268°F) indicated?	Replace MAF sensor (built-in IAT sensor).	"BRN" wire open or poor C51-22 connection. If wire and connection are OK, substitute a known-good ECM and recheck.

DTC P0115 (DTC P0115) ENGINE COOLANT TEMP. SENSOR CIRCUIT MALFUNCTION WIRING DIAGRAM

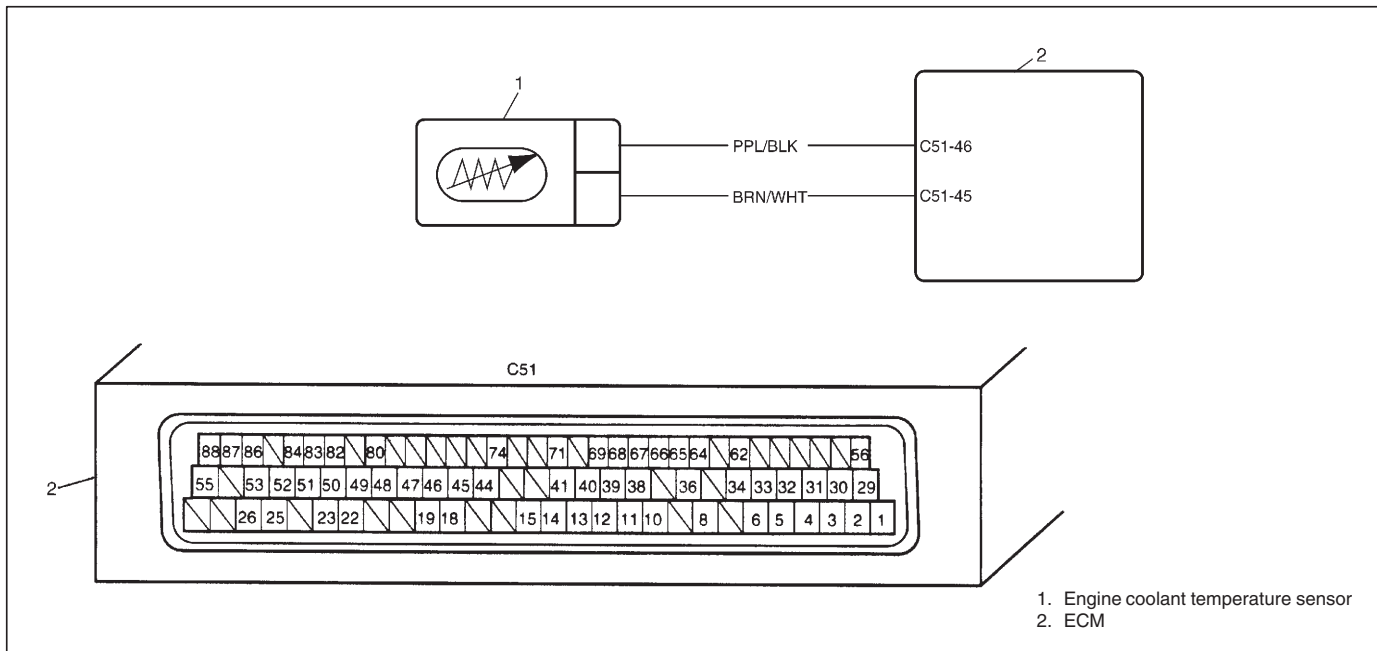

DTC CONFIRMATION PROCEDURE

- 1) Connect scan tool to DLC with ignition switch OFF.
- 2) Turn ON ignition switch and clear DTC, pending DTC and freeze frame data by using scan tool and run engine at idle speed for 10 sec. or more.
- 3) Check DTC and pending DTC by using scan tool.

TROUBLESHOOTING

STEP	ACTION	YES	NO
1	Was "ENGINE DIAG. FLOW TABLE" performed?	Go to Step 2.	Go to "ENGINE DIAG. FLOW TABLE".
2	Check Wire Harness. 1) Remove intercooler referring to "INTERCOOLER" in Section 6E3. 2) Disconnect ECT sensor connector with ignition switch OFF. 3) Check for proper connection to ECT sensor at "PPL/BLK" and "BRN/WHT" wire terminals. 4) If OK, check voltage between "PPL/BLK" and "BRN/WHT" wire terminals of harness side with ignition switch ON. Is voltage about 5 V?	Go to Step 3.	"PPL/BLK" wire open or shorted to power/ground. "BRN/WHT" wire open. Poor C51-46 or C51-45 connection.
3	Check ECT Sensor and Its Circuit 1) Connect ECT sensor to its connector. 2) Connect scan tool to DLC with ignition switch OFF and run engine. Does coolant temp. on scan tool vary?	Substitute a known-good ECM and recheck.	Faulty ECT sensor.

DTC P0121 (DTC P0120) THROTTLE POSITION CIRCUIT RANGE/PERFORMANCE PROBLEM
DTC P0604 (P0120) THROTTLE POSITION SENSOR MONITORING SYSTEM MALFUNCTION

WIRING DIAGRAM

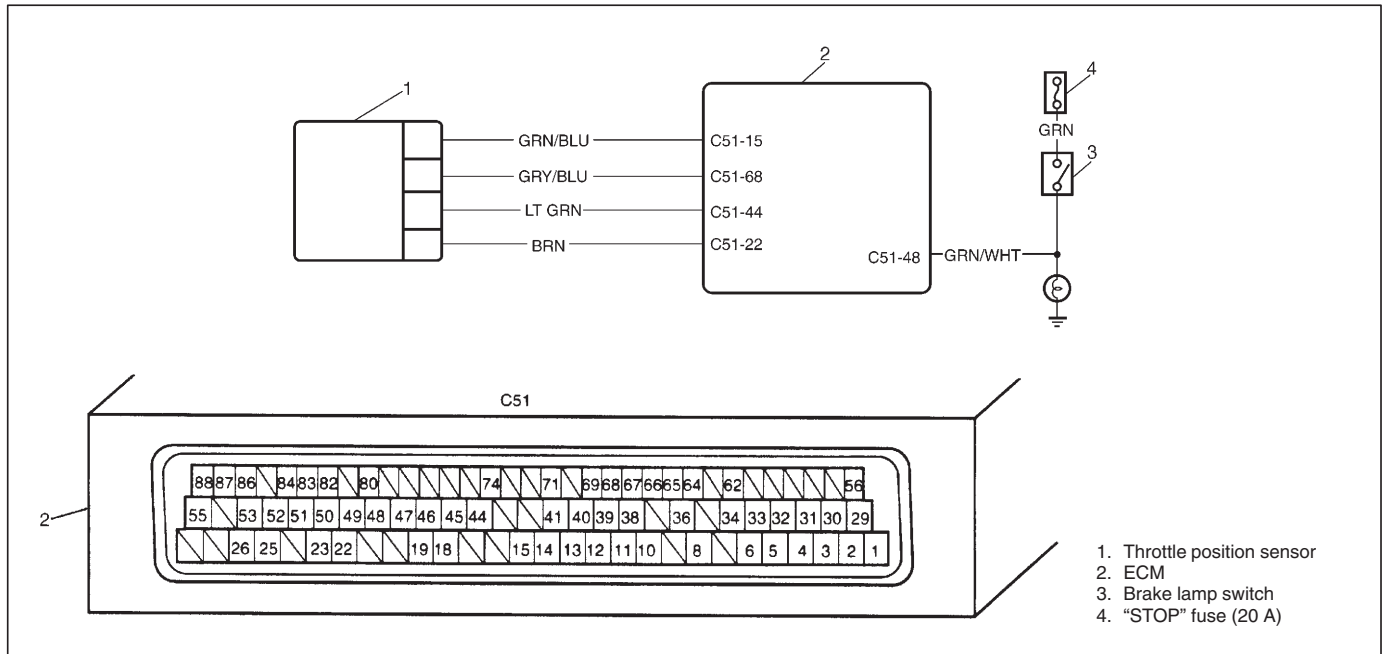

DTC CONFIRMATION PROCEDURE

- 1) Connect scan tool to DLC with ignition switch OFF.
- 2) Turn ON ignition switch and clear DTC, pending DTC and freeze frame data by using scan tool and run engine at idle speed for 10 sec. or more.
- 3) Check DTC and pending DTC by using scan tool.

TROUBLESHOOTING

STEP	ACTION	YES	NO
1	Was "ENGINE DIAG. FLOW TABLE" performed?	Go to Step 2.	Go to "ENGINE DIAG. FLOW TABLE".
2	Check Sensor Power Supply Circuit Is DTC below also indicated? <Using Suzuki mode of Suzuki Scan tool> P1614 <Using Generic Scan tool or Euro mode of Suzuki Scan tool> P0560	Go to DTC P1614 (P0560) Diag. Flow Table.	Go to Step 3.
3	Check Wire Harness. 1) Disconnect connector from TP sensor with ignition switch OFF. 2) Check for proper connection to TP sensor at each terminals. 3) If OK, then with ignition switch ON, check voltage between "LT GRN" wire and "BRN" wire terminals at connector of TP sensor. Is voltage about 5 V?	Go to Step 4.	"LT GRN" wire open, "BRN" wire open, poor C51-44 connection, or poor C51-22 connection. If wire and connection are OK, substitute a known-good ECM and recheck.
4	Check TP Sensor output voltage. 1) Remove ECM cover referring to "Voltage Check" in this section. 2) With ignition switch ON, check voltage between C51-15 and ground, when accelerator pedal is at idle position to fully depressed position. Is voltage 0.5 – 3.35 V?	Substitute a known-good ECM and recheck.	"GRN/BLU" wire open, "GRN/BLU" wire shorted to ground circuit/power circuit. Poor TP sensor connector. If wire and connection are OK, substitute a known-good TP sensor.

DTC P0180 FUEL TEMP. SENSOR CIRCUIT MALFUNCTION

WIRING DIAGRAM

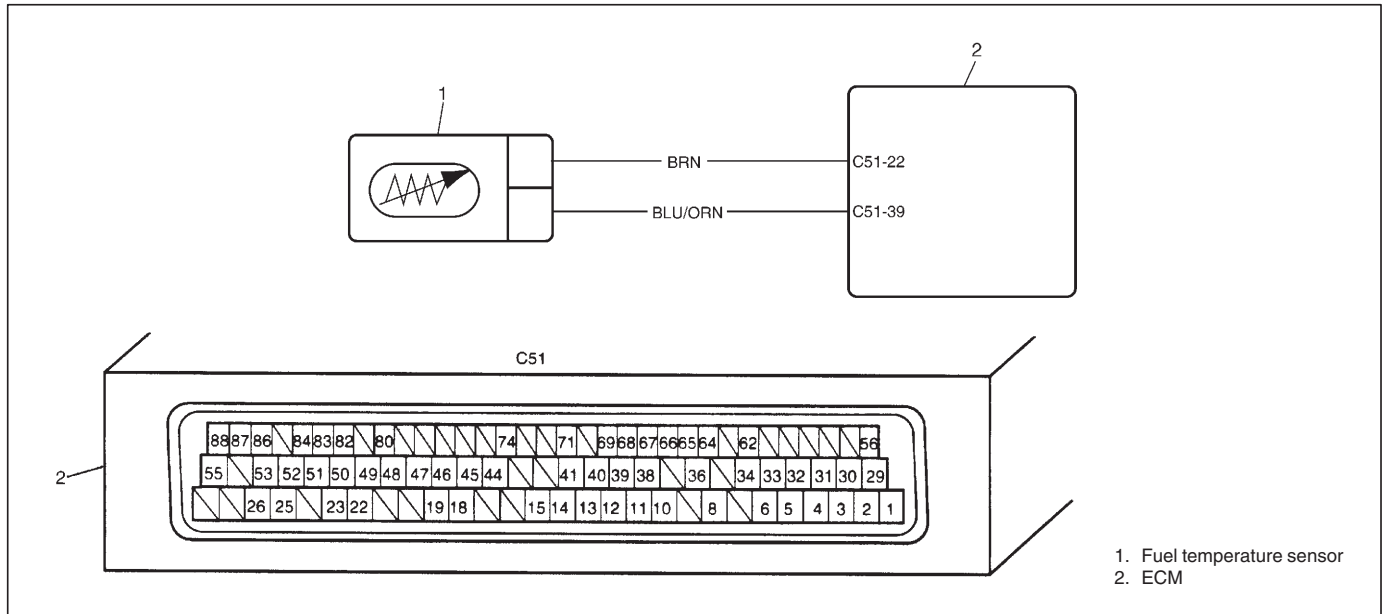

DTC CONFIRMATION PROCEDURE

- 1) Connect scan tool to DLC with ignition switch OFF.
- 2) Turn ON ignition switch and clear DTC, pending DTC and freeze frame data by using scan tool and run engine at idle speed for 10 sec. or more.
- 3) Check DTC and pending DTC by using scan tool.

TROUBLESHOOTING

STEP	ACTION	YES	NO
1	Was "ENGINE DIAG. FLOW TABLE" performed?	Go to Step 2.	Go to "ENGINE DIAG. FLOW TABLE".
2	1) Remove intercooler referring to "INTERCOOLER" in Section 6E3. 2) Disconnect fuel temp. sensor connector with ignition switch OFF. 3) Check for proper connection to fuel temp. sensor at "BLU/ORN" and "BRN" wire terminals. 4) If OK, check voltage between "BLU/ORN" and "BRN" wire terminals with ignition switch ON. Is voltage about 5 V?	Go to Step 3.	"BLU/ORN" wire open or shorted to power/ground. "BRN" wire open. Poor C51-39 or C51-22 connection. If wire and connection are OK, substitute a known-good ECM and recheck.
3	1) Check fuel temp. sensor for resistance referring to "FUEL TEMPERATURE SENSOR" in Section 6E3. Is resistance as specified?	Substitute a known-good fuel temp. sensor and recheck.	Replace fuel temp. sensor.

DTC P0190 (P0190) FUEL RAIL PRESSURE SENSOR CIRCUIT MALFUNCTION WIRING DIAGRAM

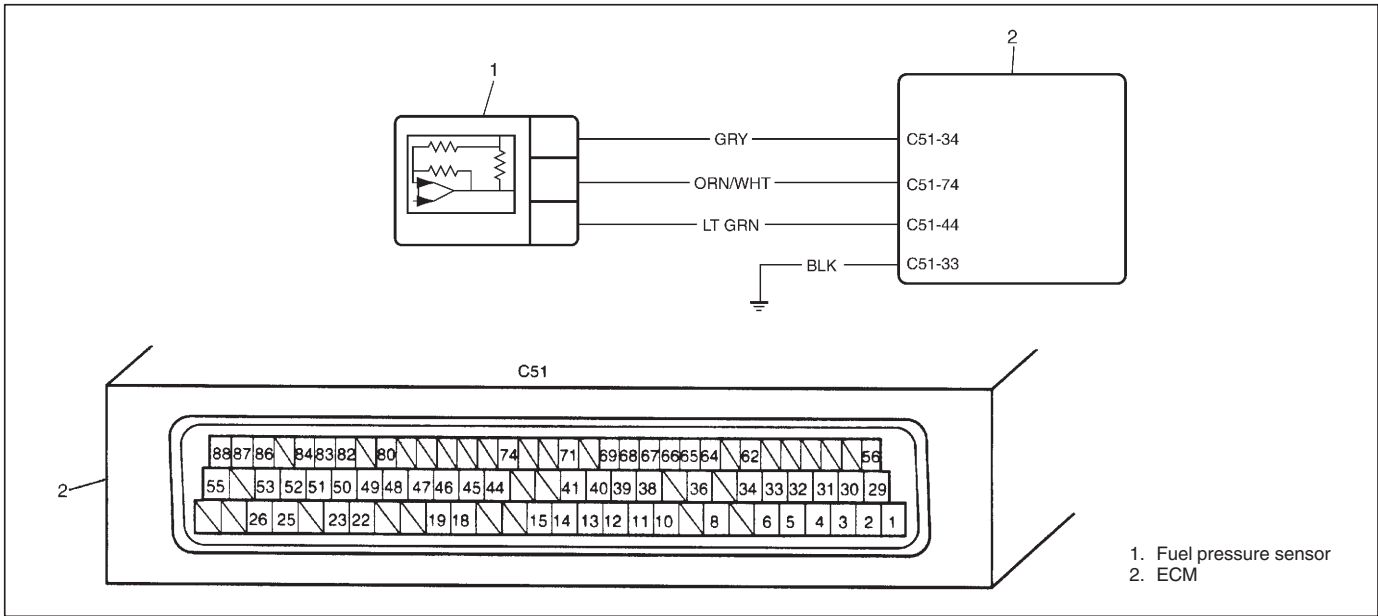

DTC CONFIRMATION PROCEDURE

- 1) Connect scan tool to DLC with ignition switch OFF.
- 2) Turn ON ignition switch and clear DTC, pending DTC and freeze frame data by using scan tool and run engine at idle speed for 10 sec. or more.
- 3) Check DTC and pending DTC by using scan tool.

TROUBLESHOOTING

STEP	ACTION	YES	NO
1	Was "ENGINE DIAG. FLOW TABLE" performed?	Go to Step 2.	Go to "ENGINE DIAG. FLOW TABLE".
2	<p>Check Sensor Power Supply Circuit</p> <p>1) Connect scan tool to DLC with ignition switch OFF and then turn ignition switch ON.</p> <p>2) Does scan tool indicate DTC as shown below? <Using Suzuki mode of Suzuki Scan tool> P1614 <Using Generic Scan tool or Euro mode of Suzuki Scan tool> P0560</p>	Go to DTC P1614 (P0560) Diag. Flow Table.	Go to Step 3.
3	<p>Check Wire Harness</p> <p>1) Disconnect connector from fuel pressure sensor with ignition switch OFF.</p> <p>2) Check for proper connection to fuel pressure sensor at each terminals.</p> <p>3) If OK, then with ignition switch ON, check voltage between "LT GRN" wire and "GRY" wire terminals at connector of fuel pressure sensor. Is voltage about 5 V?</p>	Go to Step 4.	<p>"LT GRN" wire open, "LT GRN" wire shorted to ground circuit/power circuit, "GRY" wire open, poor C51-44 connection, or poor C51-34 connection.</p> <p>If wire and connection are OK, substitute a known-good ECM and recheck.</p>
4	<p>Check Fuel Pressure Sensor Output Voltage</p> <p>1) Remove ECM cover referring to "Voltage Check" in this section.</p> <p>2) Connect fuel pressure sensor connector.</p> <p>3) Start engine and check voltage between C51-74 and C51-33 terminal at idle speed. Is voltage about 1.3 V?</p>	Substitute a known-good ECM and recheck.	<p>"ORN/WHT" wire open, "ORN/WHT" wire shorted to ground circuit/power circuit.</p> <p>If wire and connection are OK, substitute a known-good fuel pressure sensor and recheck.</p>

DTC P0191 (P0230) FUEL RAIL PRESSURE SENSOR/PRESSURE REGULATOR CONSISTENCY FUNCTION
DTC P1112 (P0230) FUEL PRESSURE MONITORING CIRCUIT MALFUNCTION
WIRING DIAGRAM

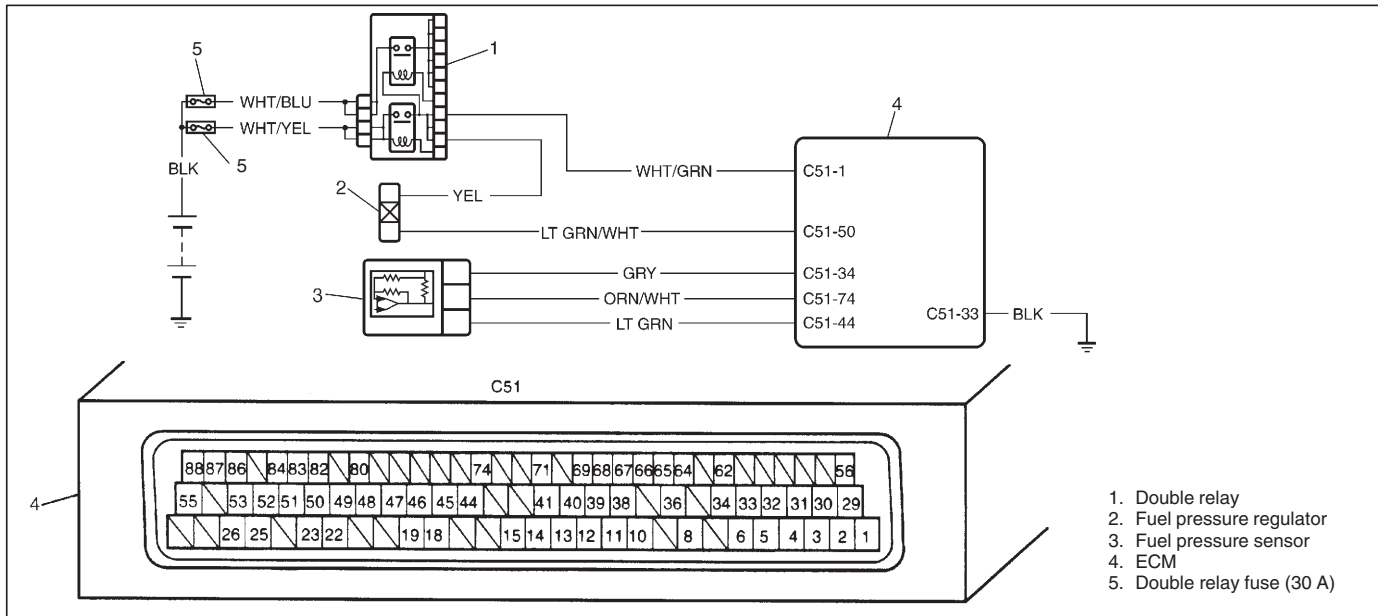

- 1. Double relay
- 2. Fuel pressure regulator
- 3. Fuel pressure sensor
- 4. ECM
- 5. Double relay fuse (30 A)

DTC CONFIRMATION PROCEDURE

- 1) Connect scan tool to DLC with ignition switch OFF.
- 2) Turn ON ignition switch and clear DTC, pending DTC and freeze frame data by using scan tool and run engine at idle speed for 10 sec. or more.
- 3) Then run engine 1000 rpm or more for 10 sec.
- 4) Check DTC and pending DTC by using scan tool.

TROUBLESHOOTING

STEP	ACTION	YES	NO
1	Was "ENGINE DIAG. FLOW TABLE" performed?	Go to Step 2.	Go to "ENGINE DIAG. FLOW TABLE".
2	Check Fuel Shortage 1) Is there enough fuel in fuel tank?	Go to Step 3.	Supply fuel into fuel tank.
3	Check Wire Harness 1) With ignition switch OFF, disconnect ECM connector. 2) Check for proper connection to ECM at C51-1 and C51-50 terminals. 3) If OK, check resistance between C51-1 and C51-50 terminals. Is resistance 2 – 3 Ω?	Go to Step 4.	Faulty "WHT/GRN" wire, "YEL" wire or "LT GRN/WHT" wire. If wire is OK, substitute a known-good double relay or injection pump and recheck.
4	Check Fuel Pressure Sensor Output Voltage 1) Remove ECM cover referring to "Voltage Check" in the Section. 2) Connect fuel pressure sensor connector. 3) Start engine and check voltage between C51-74 and C51-33 terminal at idle speed. Is voltage about 1.3 V?	Go to Step 5.	"ORN/WHT" wire open, "ORN/WHT" wire shorted to ground circuit/power circuit. Poor fuel pressure sensor connector terminal connection. If wire and connection are OK, substitute a known-good fuel pressure sensor and recheck.
5	Check Fuel Leakage 1) Perform step 1), 2) and 3) of "DTC CONFIRMATION PROCEDURE". 2) Check fuel leakage on Fuel System. Is it in good condition?	<ul style="list-style-type: none"> ● Fuel line clogged. ● Faulty fuel pressure regulator. If OK, substitute a known-good ECM and recheck. (See NOTE.)	Repair or replace.

NOTE:

If DTC is checked using generic scan tool only and DTC P1138 (P0230) Diag. Flow Table is not performed yet, go to the table before ECM replacement.

TROUBLESHOOTING

STEP	ACTION	YES	NO
1	Was "ENGINE DIAG. FLOW TABLE" performed?	Go to Step 2.	Go to "ENGINE DIAG. FLOW TABLE".
2	<p>Check Fuel Injector Circuit For Short</p> <p>1) With ignition switch OFF, disconnect ECM connector.</p> <p>2) Check for proper connection to ECM at C51-2, C51-30, C51-5, C51-6, C51-3, C51-31, C51-4 and C51-32 terminals.</p> <p>3) If OK, disconnect connector at all fuel injectors.</p> <p>4) Check for resistance between injector connector terminals.</p> <p>Is resistance between terminals of all fuel injectors infinity (∞)?</p>	Go to Step 3.	Short circuit between "PNK" wire and "RED" wire, "PNK/BLK" wire and "RED/BLK" wire, "PNK/GRN" wire and "RED/GRN" wire, or "PNK/BLU" wire and "RED/BLU" wire.
3	<p>Check Fuel Injector Circuit For Open</p> <p>1) Connect connector to all fuel injectors.</p> <p>2) Check for resistance between following terminals of ECM connector.</p> <p>C51-2 and C51-30: 0.56 Ω (maximum)</p> <p>C51-5 and C51-6: 0.56 Ω (maximum)</p> <p>C51-3 and C51-31: 0.56 Ω (maximum)</p> <p>C51-4 and C51-32: 0.56 Ω (maximum)</p> <p>Is check result as specified?</p>	Substitute a known-good ECM and recheck.	Open "PNK" wire, "RED" wire, "PNK/BLK" wire, "RED/BLK" wire, "PNK/GRN" wire, "RED/GRN" wire, "PNK/BLU" wire or "RED/BLU" wire. If wire is OK, substitute a known-good fuel injector and recheck.

DTC P0215 DOUBLE RELAY CIRCUIT MALFUNCTION WIRING DIAGRAM

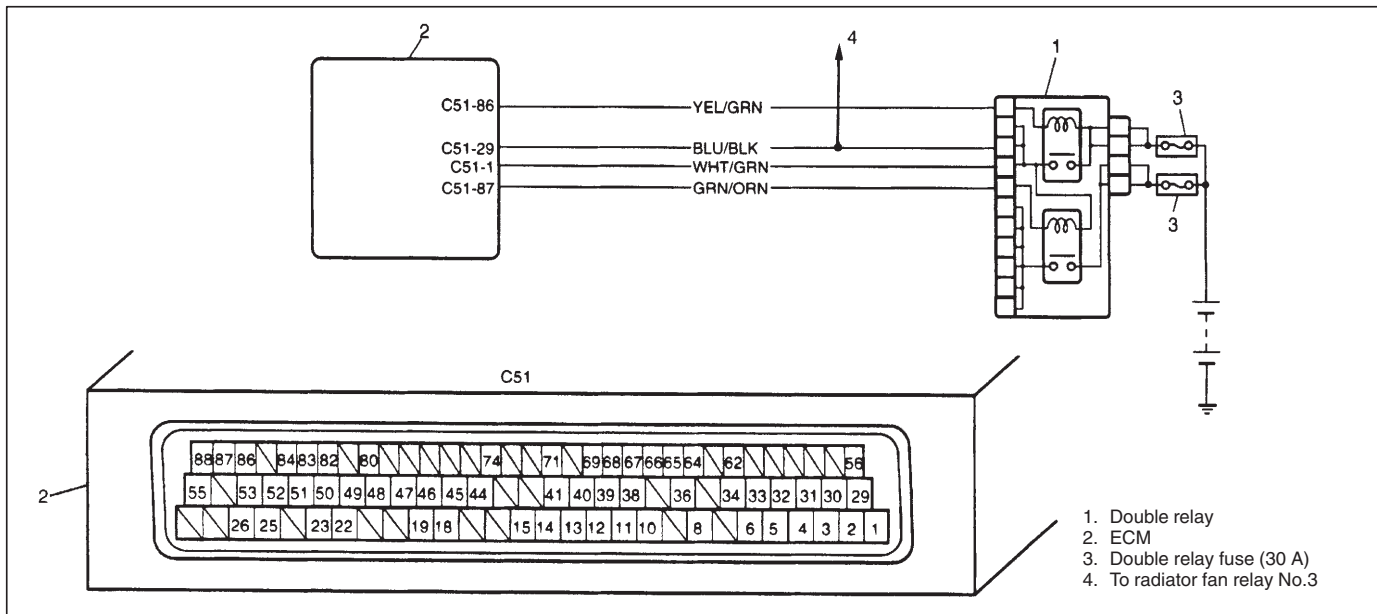

DTC CONFIRMATION PROCEDURE

- 1) Connect scan tool to DLC with ignition switch OFF.
- 2) Turn ON ignition switch and clear DTC, pending DTC and freeze frame data by using scan tool.
- 3) Turn ON ignition switch after OFF for 5 sec.
- 4) Check DTC and pending DTC by using scan tool.

TROUBLESHOOTING

STEP	ACTION	YES	NO
1	Was "ENGINE DIAG. FLOW TABLE" performed?	Go to Step 2.	Go to "ENGINE DIAG. FLOW TABLE".
2	Check Double Relay Function 1) Turn ignition switch ON for 5 sec. and then OFF. Is click of double relay heard from double relay at 2 sec. after ignition switch OFF?	Substitute a known-good ECM and recheck.	Go to Step 3.
3	1) Remove ECM cover referring to "Voltage Check" in this section. 2) Check voltage between C51-29/1 and ground. Ignition switch ON: 10 – 14 V Ignition switch OFF: about 0 V Is check result as specified?	Poor C51-29/1 connection. If connection is OK, substitute a known-good ECM and recheck.	Go to Step 4.
4	Check Double Relay 1) Check double relay referring to Section 6E3. Is it in good condition?	Go to Step 5.	Faulty double relay.
5	1) Check voltage between C51-86 and ground. Ignition switch ON: about 0 V Ignition switch OFF: 10 – 14 V Is check result as specified?	<ul style="list-style-type: none"> ● Poor C51-86 connection, ● "BLU/BLK" wire open/short or ● "WHT/GRN" wire open/short 	"YEL/GRN" wire open or short.

DTC P0230 FUEL PUMP SUPPLY CIRCUIT MALFUNCTION WIRING DIAGRAM

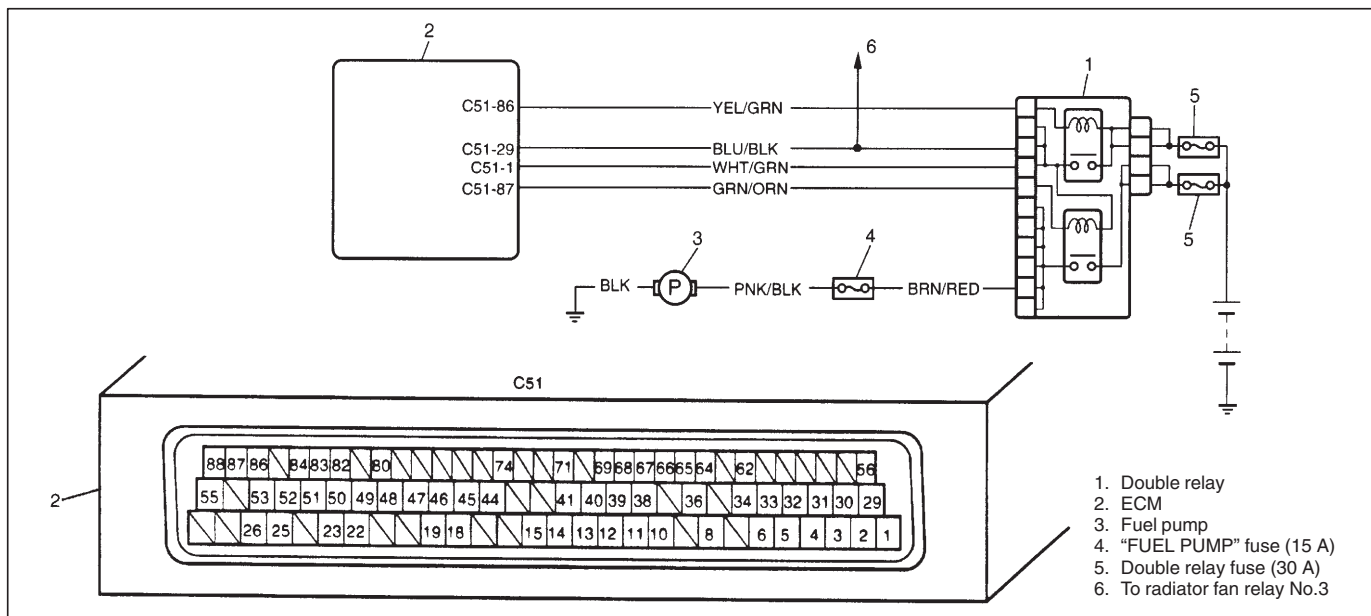

DTC CONFIRMATION PROCEDURE

- 1) Connect scan tool to DLC with ignition switch OFF.
- 2) Turn ON ignition switch and clear DTC, pending DTC and freeze frame data by using scan tool and run engine at idle speed for 10 sec. or more.
- 3) Turn ON ignition switch after OFF for 5 sec.
- 4) Check DTC and pending DTC by using scan tool.

TROUBLESHOOTING

STEP	ACTION	YES	NO
1	Was "ENGINE DIAG. FLOW TABLE" performed?	Go to Step 2.	Go to "ENGINE DIAG. FLOW TABLE".
2	Is operating sound heard from fuel pump?	Substitute a known-good ECM and recheck.	Go to Step 3.
3	Check Double Relay 1) Check double relay referring to Section 6E3. Is it in good condition?	Go to Step 4.	Faulty double relay.
4	Check Fuel Pump Output Circuit 1) Remove ECM cover referring to "Voltage Check" in this section. 2) Check voltage between C51-87 and ground. • Within 5 sec. after ignition switch ON: about 0 V • Over 5 sec. after Ignition switch OFF: 10 – 14 V Is check result as specified?	<ul style="list-style-type: none"> • Poor C51-87 connection • "BLK", "PNK/BLK" or "BRN/RED" wire open/short • Fuse broken or • Faulty fuel pump If all are OK, substitute a known-good ECM and recheck.	"GRN/OGN" wire open/short.

DTC P0243 (P0243) TURBO PRESSURE SOLENOID VALVE CIRCUIT RANGE/ PERFORMANCE PROBLEM

WIRING DIAGRAM

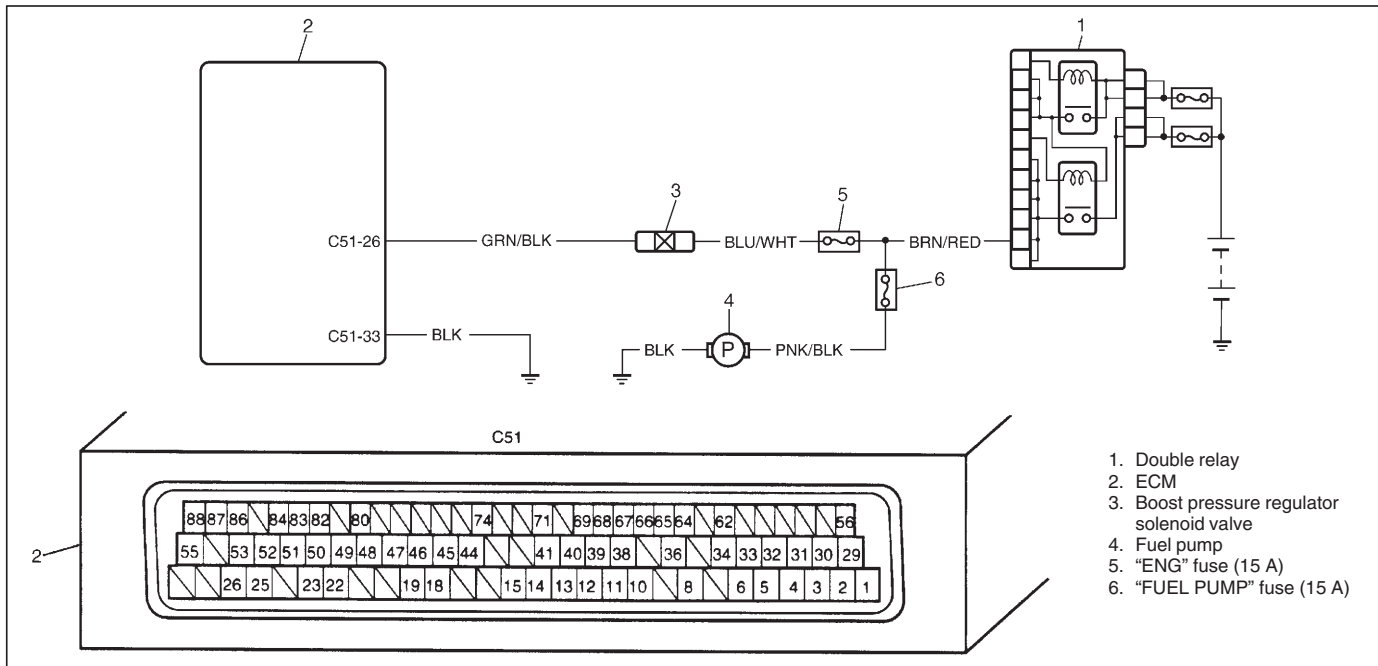

DTC CONFIRMATION PROCEDURE

- 1) Connect scan tool to DLC with ignition switch OFF.
- 2) Turn ON ignition switch and clear DTC, pending DTC and freeze frame data by using scan tool.
- 3) Check DTC and pending DTC by using scan tool.

TROUBLESHOOTING

STEP	ACTION	YES	NO
1	Was "ENGINE DIAG. FLOW TABLE" performed?	Go to Step 2.	Go to "ENGINE DIAG. FLOW TABLE".
2	Is operating sound heard from fuel pump?	Go to Step 3.	Proceed to DTC P0230 Diag. Flow table.
3	<p>Check Wire Harness</p> <p>1) Disconnect boost pressure regulator solenoid valve connector with ignition switch OFF.</p> <p>2) With ignition switch ON, check voltage between "BLU/WHT" wire terminal of solenoid valve connector disconnected and ground.</p> <p>Within 5 sec. after ignition switch ON: about 12 V</p> <p>Over 5 sec. after ignition switch ON: 0 V</p> <p>Is check result as specified?</p>	Go to Step 4.	"BLU/WHT" wire open, shorted to power/ground or fuse broken.
4	<p>Check Boost Pressure Regulator Solenoid Valve</p> <p>1) Check solenoid valve referring to Section 6E3.</p> <p>Is check result as specified?</p>	"GRN/BLK" wire open or shorted to power/ground. Poor C51-26 connection. If wire and connection are OK, substitute a known-good ECM and recheck. (See NOTE.)	Faulty solenoid valve.

NOTE:

If DTC is checked using generic scan tool only and DTC P0245 (P0243)/P0246 (P0243) Diag. Flow Table is not performed yet, go to the table before ECM replacement.

DTC P0245 (P0243)/P0246 (P0243) TURBO PRESSURE SOLENOID VALVE CIRCUIT RANGE/PERFORMANCE PROBLEM

WIRING DIAGRAM

Refer to DTC P0243 (P0243).

TROUBLESHOOTING

STEP	ACTION	YES	NO
1	Was "ENGINE DIAG. FLOW TABLE" performed?	Go to Step 2.	Go to "ENGINE DIAG. FLOW TABLE".
2	Check Vacuum Circuit Check vacuum circuit for leak and clogging. Is it in good condition?	Go to Step 3.	Repair or replace.
3	Check boost pressure regulator solenoid valve for resistance referring to "BOOST PRESSURE REGULATOR SOLENOID VALVE" in Section 6E3. Is resistance as specified?	Substitute a known-good ECM and recheck. (See NOTE.)	Replace boost pressure regulator solenoid valve.

NOTE:

If DTC is checked using generic scan tool only and DTC P0243 (P0243) Diag. Flow Table is not performed yet, go to the table before ECM replacement.

DTC CONFIRMATION PROCEDURE

- 1) Connect scan tool to DLC with ignition switch OFF.
- 2) Turn ON ignition switch and clear DTC, pending DTC and freeze frame data by using scan tool.
- 3) Run engine over 2500 rpm for 10 sec.
- 4) Check DTC and pending DTC by using scan tool.

DTC P0380 (P0380)/P1404 (P0380) PRE/POST HEAT RELAY CIRCUIT MALFUNCTION WIRING DIAGRAM

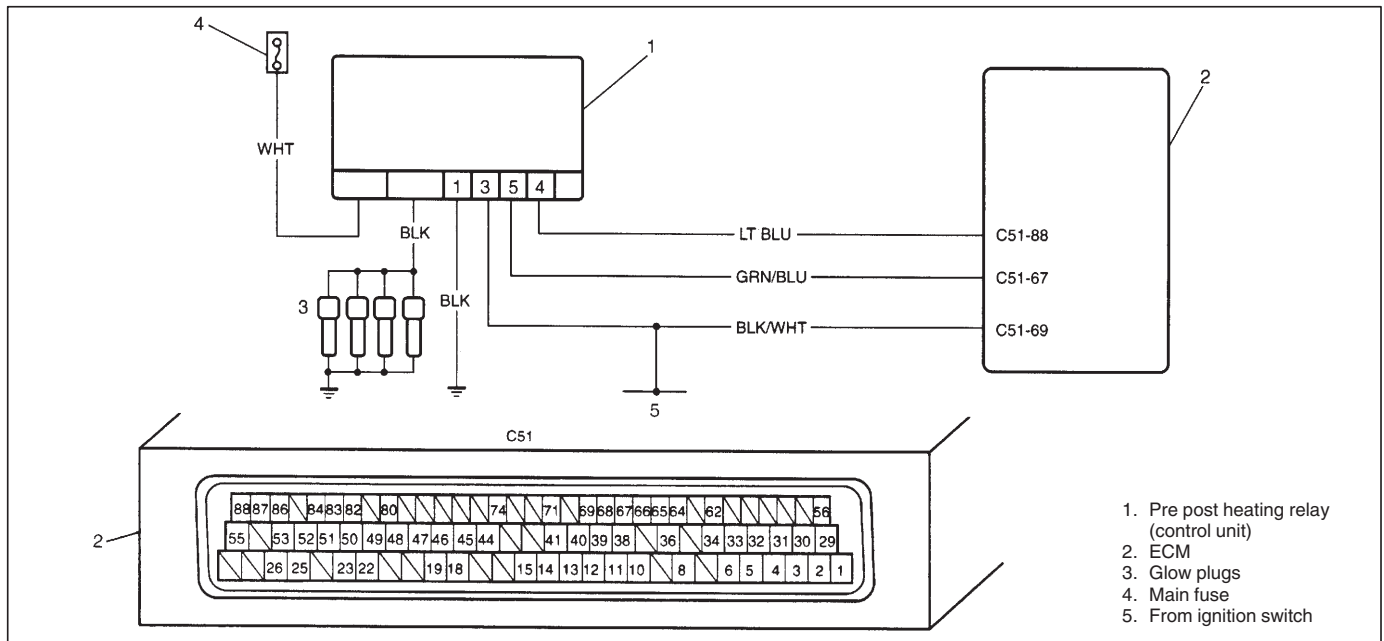

DTC CONFIRMATION PROCEDURE

- 1) Connect scan tool to DLC with ignition switch OFF.
- 2) Turn ON ignition switch and clear DTC, pending DTC and freeze frame data by using scan tool.
- 3) Turn ignition switch ON for 30 sec. after OFF. Then run engine at idle speed for 30 sec.
- 4) Check DTC and pending DTC by using scan tool.

TROUBLESHOOTING

STEP	ACTION	YES	NO
1	Was "ENGINE DIAG. FLOW TABLE" performed?	Go to Step 2.	Go to "ENGINE DIAG. FLOW TABLE".
2	Check Wire Harness 1) Remove ECM cover from ECM referring to "CHECK VOLTAGE" in this section. 2) Check voltage between C51-88/C51-69 and ground with ignition switch ON. Are they about 12 V?	Go to Step 3.	<ul style="list-style-type: none"> ● "LT BLU" wire open or short to ground, or ● "BLK/WHT" wire open or short to ground
3	Check Wire Harness 1) Check voltage between C51-67 and ground with ignition switch ON. Is it about 0 V?	<ul style="list-style-type: none"> ● Poor C51-88 or C51-67 connection If connections are in good condition, substitute a known-good ECM and recheck. 	<ul style="list-style-type: none"> ● "GRN/BLU" wire open or short, ● "BLK" wire (between pre-post heating relay and ground) open or short to ground ● "BLK" wire (between pre-post heating relay and glow plug) open or short to ground ● Poor glow plug "BLK" wire terminal connection If all are OK, substitute a known-good ECM and recheck.

DTC P0381 GLOW INDICATOR LAMP CIRCUIT MALFUNCTION WIRING DIAGRAM

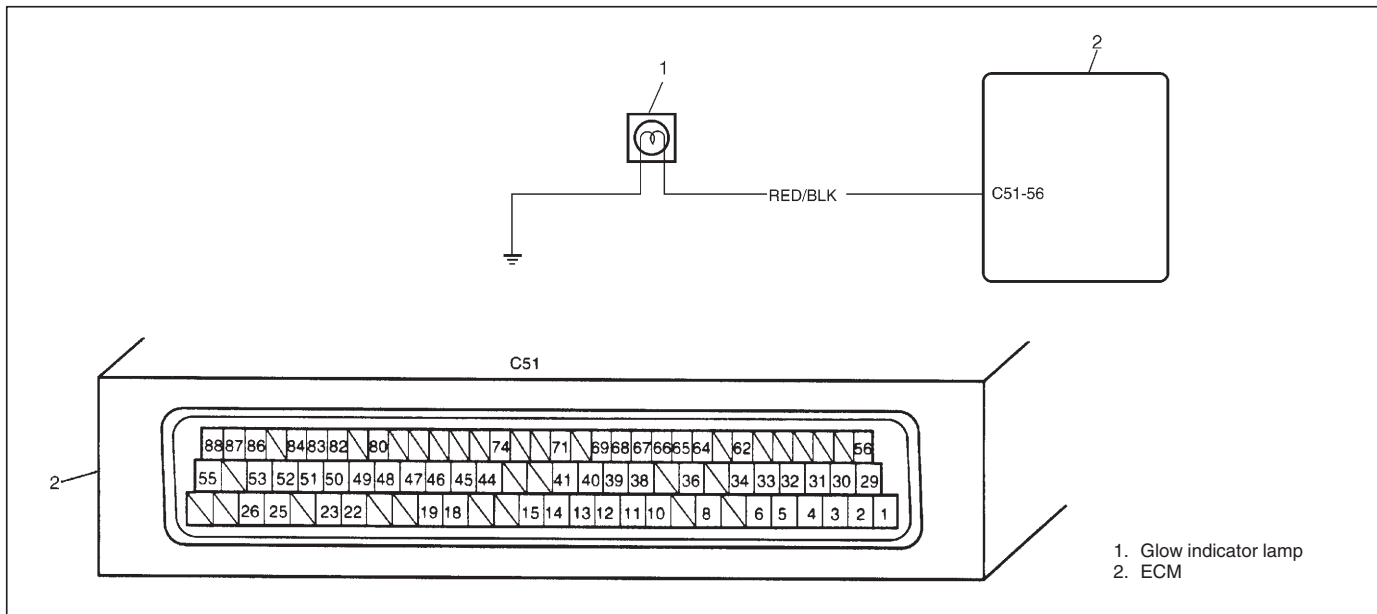

DTC CONFIRMATION PROCEDURE

- 1) Connect scan tool to DLC with ignition switch OFF.
- 2) Turn ON ignition switch and clear DTC, pending DTC and freeze frame data by using scan tool.
- 3) Turn ignition switch ON for 30 sec. after OFF.
- 4) Check DTC and pending DTC by using scan tool.

TROUBLESHOOTING

STEP	ACTION	YES	NO
1	Was "ENGINE DIAG. FLOW TABLE" performed?	Go to Step 2.	Go to "ENGINE DIAG. FLOW TABLE".
2	Check Wire Harness <Not Using Suzuki Scan Tool> 1) Disconnect connector at ECM with ignition switch OFF. 2) Supply battery power (12 V) to C51-56 using service wire. Does glow indicator lamp turn on? <Using Suzuki Scan Tool> 1) Connect Suzuki scan tool to DLC. 2) Execute "Glow Indicator Lamp" in Misc Test. Does glow indicator lamp flash?	Substitute a known-good ECM and recheck.	<ul style="list-style-type: none"> ● Lamp bulb broken, ● "RED/BLK" wire open or short or ● Poor C51-56 connection

REFERENCE:

As soon as ignition is switched on, ECM turns on glow indicator lamp for a period which depends on engine coolant temp. as shown below.

Engine coolant temp. (°C)	Time turning on glow indicator lamp (sec.)
-30	20
-10	5
0	0.5
18	0

DTC P0401 (P0903) EGR SOLENOID VALVE FLOW INSUFFICIENT DETECTED
DTC P0402 (P0903) EGR SOLENOID VALVE FLOW EXCESSIVE DETECTED

DTC CONFIRMATION PROCEDURE

- 1) Connect scan tool to DLC with ignition switch OFF.
- 2) Turn ON ignition switch and clear DTC, pending DTC and freeze frame data by using scan tool.
- 3) Run engine between 700 and 2700 rpm for 10 or more.
- 4) Check DTC and pending DTC by using scan tool.

TROUBLESHOOTING

STEP	ACTION	YES	NO
1	Was "ENGINE DIAG. FLOW TABLE" performed?	Go to Step 2.	Go to "ENGINE DIAG. FLOW TABLE".
2	Check EGR vacuum circuit and intake air circuit for leak. Is it in good condition?	Go to Step 3.	Repair or replace.
3	Check EGR valve referring to "EGR VALVE" in Section 6E3. Is it in good condition?	Go to Step 4.	Faulty EGR valve.
4	Check EGR solenoid valve for resistance referring to "EGR SOLENOID VALVE" in Section 6E3. Is resistance as specified?	Substitute a known-good ECM and recheck.	Replace EGR solenoid valve.

DTC P0403 (P0403) EGR SOLENOID VALVE CIRCUIT MALFUNCTION

WIRING DIAGRAM

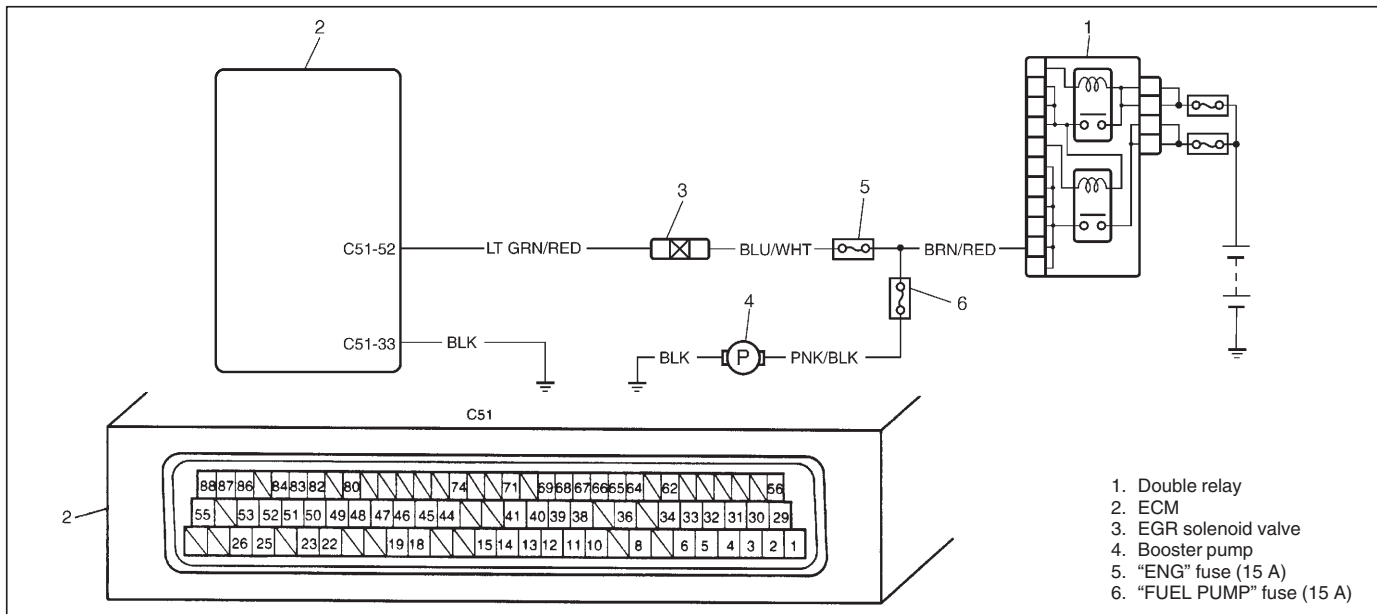

DTC CONFIRMATION PROCEDURE

- 1) Connect scan tool to DLC with ignition switch OFF.
- 2) Turn ON ignition switch and clear DTC, pending DTC and freeze frame data by using scan tool.
- 3) Check DTC and pending DTC by using scan tool.

TROUBLESHOOTING

STEP	ACTION	YES	NO
1	Was "ENGINE DIAG. FLOW TABLE" performed?	Go to Step 2.	Go to "ENGINE DIAG. FLOW TABLE".
2	Is operating sound heard from fuel pump?	Go to Step 3.	Proceed to DTC P0230 Diag. Flow table.
3	Check Wire Harness 1) Disconnect EGR solenoid valve connector with ignition switch turned OFF. 2) With ignition switch ON, check voltage between "BLU/WHT" wire terminal of solenoid valve connector and ground. <ul style="list-style-type: none"> ● Within 5 sec. after ignition switch ON: 10 – 14 V ● Over 5 sec. after ignition switch ON: about 0 V Is check result as specified?	Go to Step 4.	"BLU/WHT" wire open, shorted to power/ground or fuse broken.
4	Check EGR Solenoid Valve 1) Check solenoid valve referring to Section 6E3. Is it in good condition?	<ul style="list-style-type: none"> ● "LT GRN/RED" wire open or shorted to power/ground ● Poor C51-52 connection If wire and connection are OK, substitute a known-good ECM and recheck.	Faulty EGR solenoid valve.

DTC P0561 (P0560) STABILIZATION OF SENSOR SUPPLY
DTC P0603/P0606/P1171/P1617 ECM FUNCTION
DTC P1169 (P0170) CONDENSER VOLTAGE FUNCTION 1
DTC P1170 (P0170) CONDENSER VOLTAGE FUNCTION 2
DTC P1101 (P0105) BAROMETRIC PRESSURE SENSOR CIRCUIT MALFUNCTION

WIRING DIAGRAM

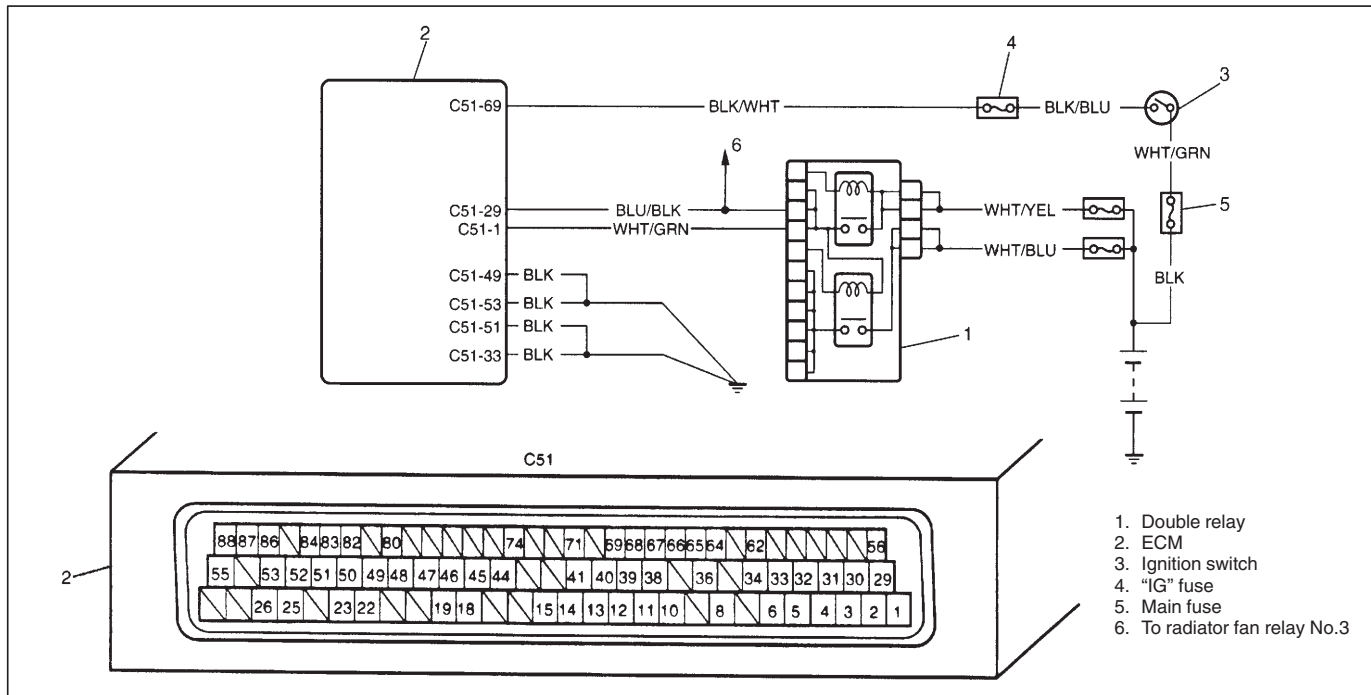

DTC CONFIRMATION PROCEDURE

- 1) Connect scan tool to DLC with ignition switch OFF.
- 2) Turn ON ignition switch and clear DTC, pending DTC and freeze frame data by using scan tool.
- 3) Run engine at idle speed for 10 sec.
- 4) Check DTC and pending DTC by using scan tool.

TROUBLESHOOTING

STEP	ACTION	YES	NO
1	Was "ENGINE DIAG. FLOW TABLE" performed?	Substitute a known-good ECM and recheck. (See NOTE.)	Go to "ENGINE DIAG. FLOW TABLE".

NOTE:

If DTC is checked using generic scan tool only and DTC P1614 (P0560) and DTC P0560 (P0560) Diag. Flow Tables are not performed yet, go to the table before ECM replacement.

DTC P1108 RADIATOR FAN HIGH SPEED CIRCUIT MALFUNCTION

WIRING DIAGRAM

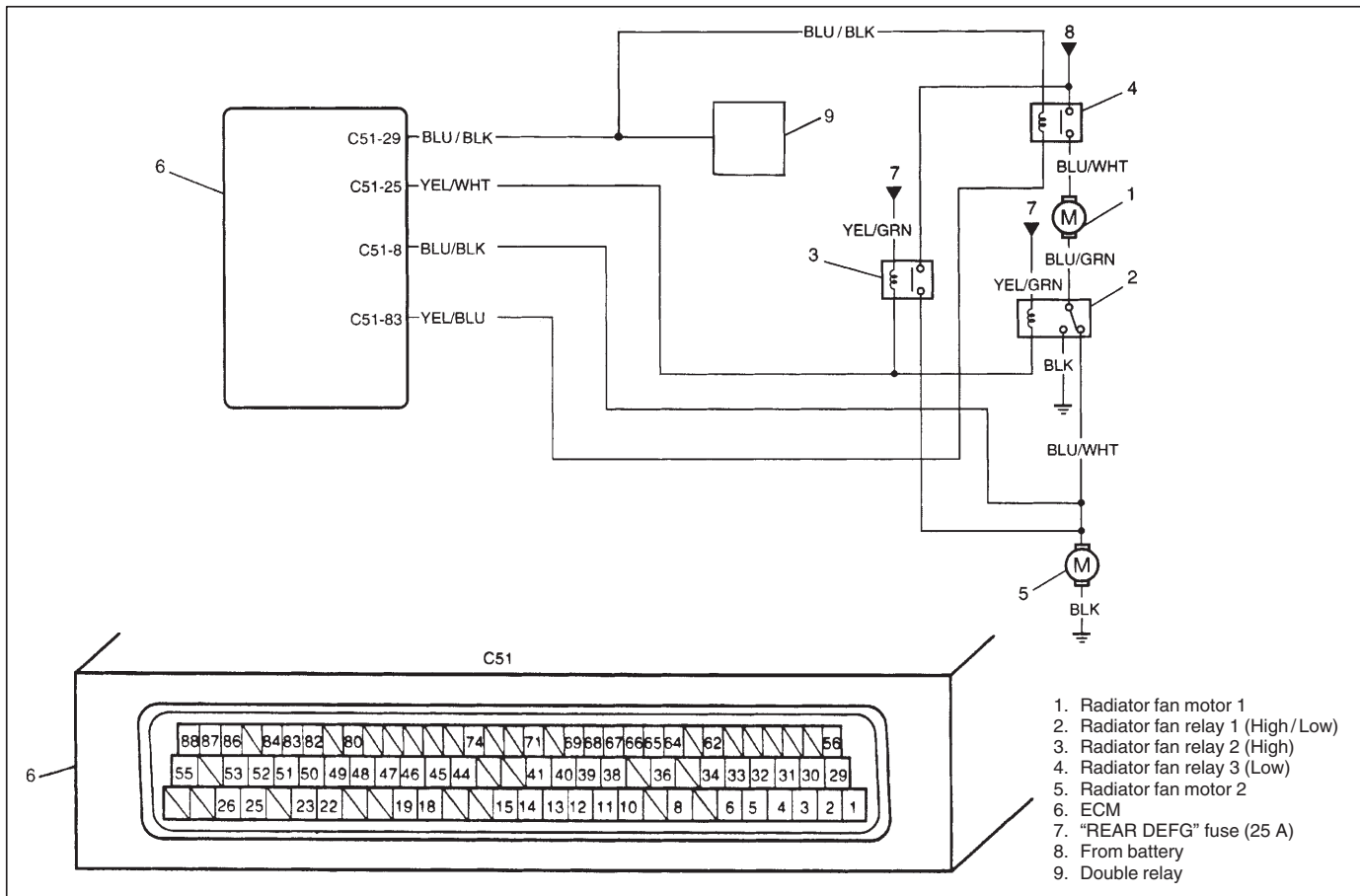

DTC CONFIRMATION PROCEDURE

- 1) Connect scan tool to DLC with ignition switch OFF.
- 2) Turn ON ignition switch and clear DTC, pending DTC and freeze frame data by using scan tool.
- 3) Start engine and warm up completely.
- 4) Check DTC and pending DTC by using scan tool.

TROUBLESHOOTING

STEP	ACTION	YES	NO
1	Was "ENGINE DIAG. FLOW TABLE" performed?	Go to Step 2.	Go to "ENGINE DIAG. FLOW TABLE".
2	Check Wire Harness 1) Disconnect connector at ECM. 2) Check voltage between C51-25 and ground with ignition switch ON. Is it about 12 V?	Poor C51-25 connection.	Go to Step 3.
3	Check Radiator Fan Relay 1) Check radiator fan relay 1 and 2 referring to Section 6E3. Are they in good condition?	<ul style="list-style-type: none"> ● "YEL/WHT" wire open or short to ground, ● "YEL/GRN" wire open or short to ground, ● Fuse broken 	Faulty radiator fan relay 1 or 2.

DTC P1109 RADIATOR FAN LOW SPEED CIRCUIT MALFUNCTION**WIRING DIAGRAM**

Refer to DTC P1108.

DTC CONFIRMATION PROCEDURE

- 1) Connect scan tool to DLC with ignition switch OFF.
- 2) Turn ON ignition switch and clear DTC, pending DTC and freeze frame data by using scan tool.
- 3) Start engine and warm up completely.
- 4) Check DTC and pending DTC by using scan tool.

TROUBLESHOOTING

STEP	ACTION	YES	NO
1	Was "ENGINE DIAG. FLOW TABLE" performed?	Go to Step 2.	Go to "ENGINE DIAG. FLOW TABLE".
2	Check Wire Harness 1) Disconnect connector at ECM. 2) Check voltage between C51-83 and ground with ignition switch ON. Is it about 12 V?	Poor C51-83 connection.	Go to Step 3.
3	Check Radiator Fan Relay 1) Check radiator fan relay 3 referring to Section 6E3. Is it in good condition?	<ul style="list-style-type: none"> ● "YEL/BLU" wire open or short to ground, ● Fuse broken 	Faulty radiator fan relay 3.

DTC P1110 A/C SIGNAL CIRCUIT MALFUNCTION WIRING DIAGRAM

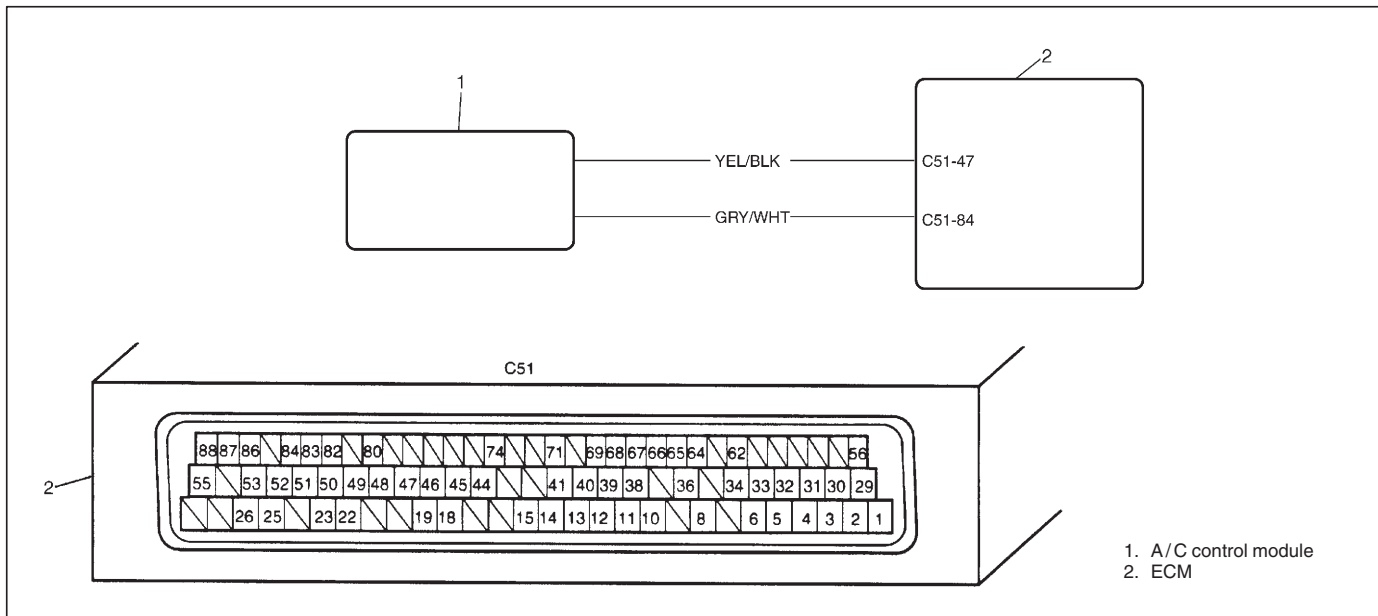

DTC CONFIRMATION PROCEDURE

- 1) Connect scan tool to DLC with ignition switch OFF.
- 2) Turn ON ignition switch and clear DTC, pending DTC and freeze frame data by using scan tool.
- 3) Start engine and turn on A/C switch and heater blower fan switch.
- 4) Check DTC and pending DTC by using scan tool.

TROUBLESHOOTING

STEP	ACTION	YES	NO
1	Was "ENGINE DIAG. FLOW TABLE" performed?	Go to Step 2.	Go to "ENGINE DIAG. FLOW TABLE".
2	<p>Check Wire Harness</p> <p>1) Remove ECM cover from ECM referring to "Voltage Check" in this section.</p> <p>2) Check voltage between C51-84 and ground at engine idling.</p> <p>Are they as follows?</p> <ul style="list-style-type: none"> ● A/C switch and heater blower switch OFF: 0 V ● A/C switch and heater blower switch ON: about 12 V 	<p>Poor C51-84 connection.</p> <p>If OK, substitute a known-good ECM and recheck.</p>	<ul style="list-style-type: none"> ● "YEL/BLK" wire open or short or ● Poor A/C control module connector connection <p>If all are in good condition, substitute a known-good A/C control module and recheck.</p>

DTC P1135 3RD PISTON DEACTIVATOR (INJECTION PUMP SOLENOID VALVE) CIRCUIT MALFUNCTION

WIRING DIAGRAM

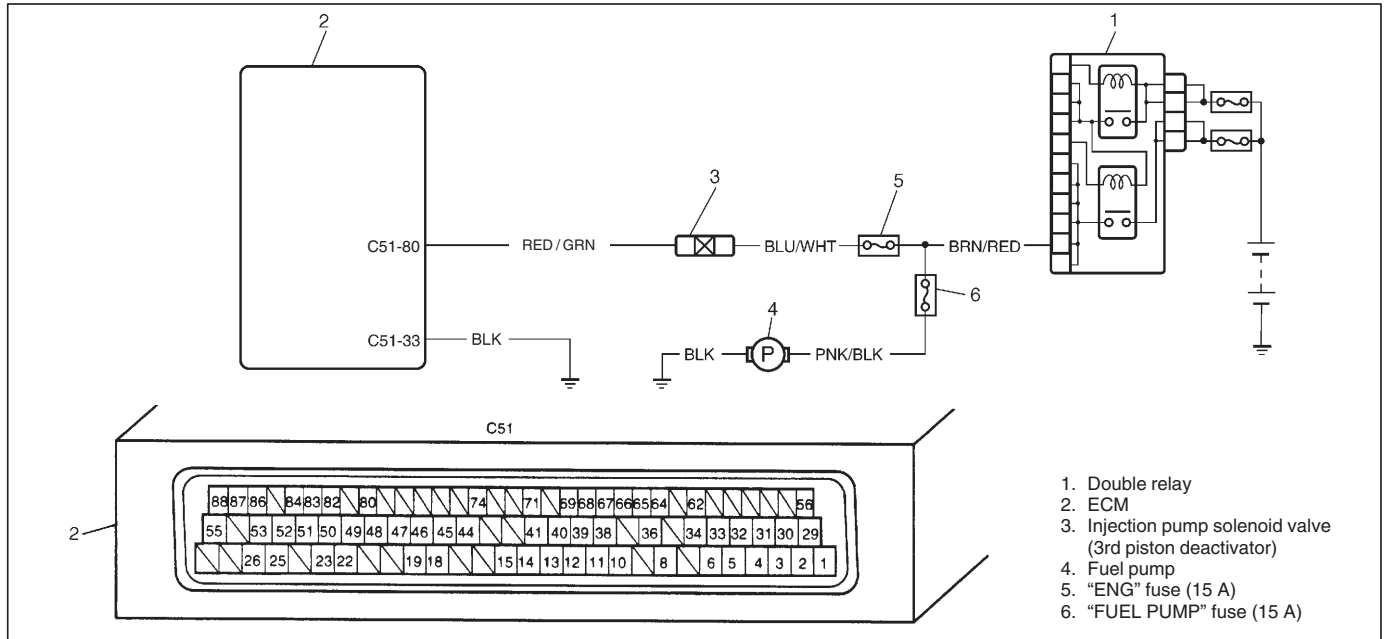

DTC CONFIRMATION PROCEDURE

- 1) Connect scan tool to DLC with ignition switch OFF.
- 2) Turn ON ignition switch and clear DTC, pending DTC and freeze frame data by using scan tool.
- 3) Run engine at idle speed.
- 4) Check DTC and pending DTC by using scan tool.

TROUBLESHOOTING

STEP	ACTION	YES	NO
1	Was "ENGINE DIAG. FLOW TABLE" performed?	Go to Step 2.	Go to "ENGINE DIAG. FLOW TABLE".
2	Is operating sound heard from fuel pump?	Go to Step 3.	Proceed to DTC P0230 Diag. Flow table.
3	Check Wire Harness 1) Disconnect injection pump solenoid valve connector with ignition switch turned OFF. 2) With ignition switch ON, check voltage between "BLU/WHT" wire terminal of solenoid valve connector and ground. ● Within 5 sec. after ignition switch ON: 10 – 14 V ● Over 5 sec. after ignition switch ON: about 0 V Is check result as specified?	Go to Step 4.	"BLU/WHT" wire open or short to ground.
4	Check Injector Pump Solenoid Valve Check resistance between "BLU/WHT" and "RED/GRN" terminal of valve. Is it between 25 – 30 Ω?	● "RED/GRN" wire open or shorted to power/ground. ● Poor C51-80 connection. If wire and connection are OK, substitute a known-good ECM and recheck.	Faulty injection pump solenoid valve.

DTC P1138 (P0230) FUEL PRESSURE REGULATOR CIRCUIT MALFUNCTION

WIRING DIAGRAM

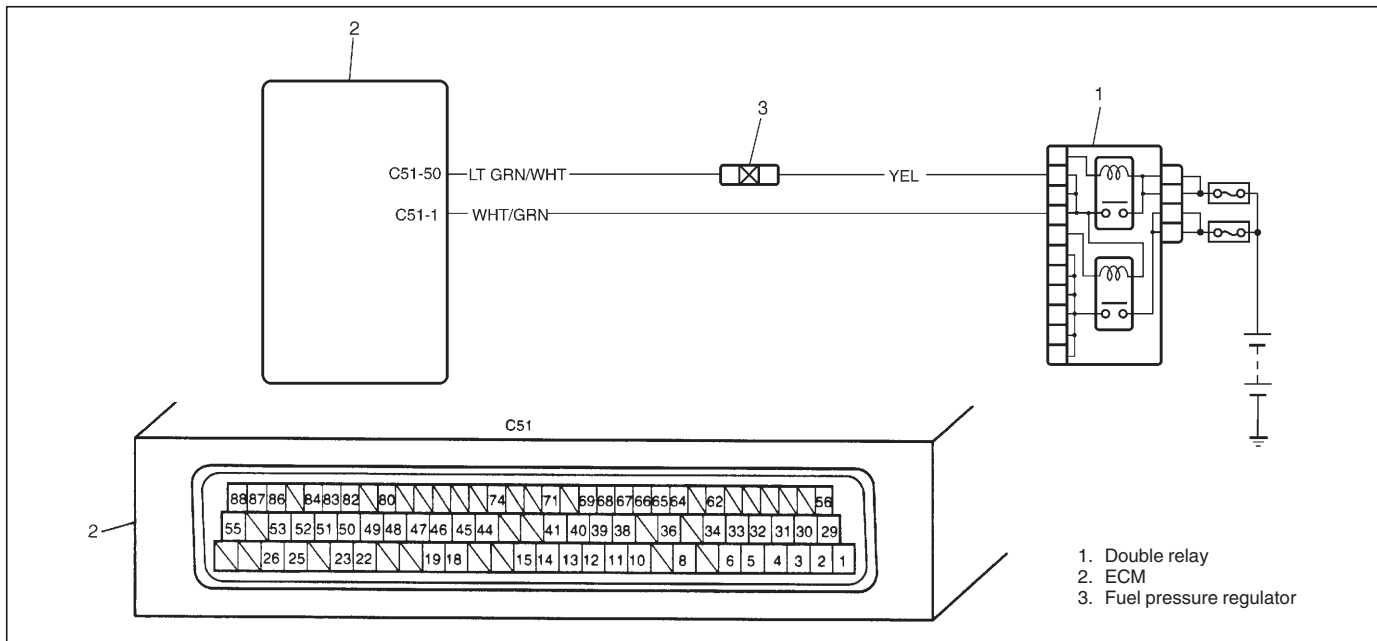

DTC CONFIRMATION PROCEDURE

- 1) Connect scan tool to DLC with ignition switch OFF.
- 2) Turn ON ignition switch and clear DTC, pending DTC and freeze frame data by using scan tool.
- 3) Run engine at idle speed for 10 sec. and stop it. Then, turn ignition switch ON.
- 4) Check DTC and pending DTC by using scan tool.

TROUBLESHOOTING

STEP	ACTION	YES	NO
1	Was "ENGINE DIAG. FLOW TABLE" performed?	Go to Step 2.	Go to "ENGINE DIAG. FLOW TABLE".
2	Check Wire Harness 1) Disconnect connector at fuel pressure regulator. 2) Check voltage between "YEL" terminal of regulator connector and ground with ignition switch ON. ● Ignition switch ON: 10 – 14 V ● Ignition switch OFF: about 0 V Is check result as specified?	Go to Step 3.	"YEL" wire open or shot to ground.
3	Check Fuel Pressure Regulator Check resistance between "YEL" and "LT GRN/WHT" terminal of valve. Is it between 2 and 3 Ω?	● "LT GRN/WHT" wire open or shorted to power/ground, ● Poor C51-50 connection If wire and connection are OK, substitute a known-good ECM and recheck. (See NOTE.)	Faulty fuel pressure regulator.

NOTE:

If DTC is checked using generic scan tool only and DTC P0191 (P0230)/P1112 (P0230) Diag. Flow Table is not performed yet, go to the table before ECM replacement.

DTC P1402 (P0510) THROTTLE SOLENOID VALVE CIRCUIT MALFUNCTION WIRING DIAGRAM

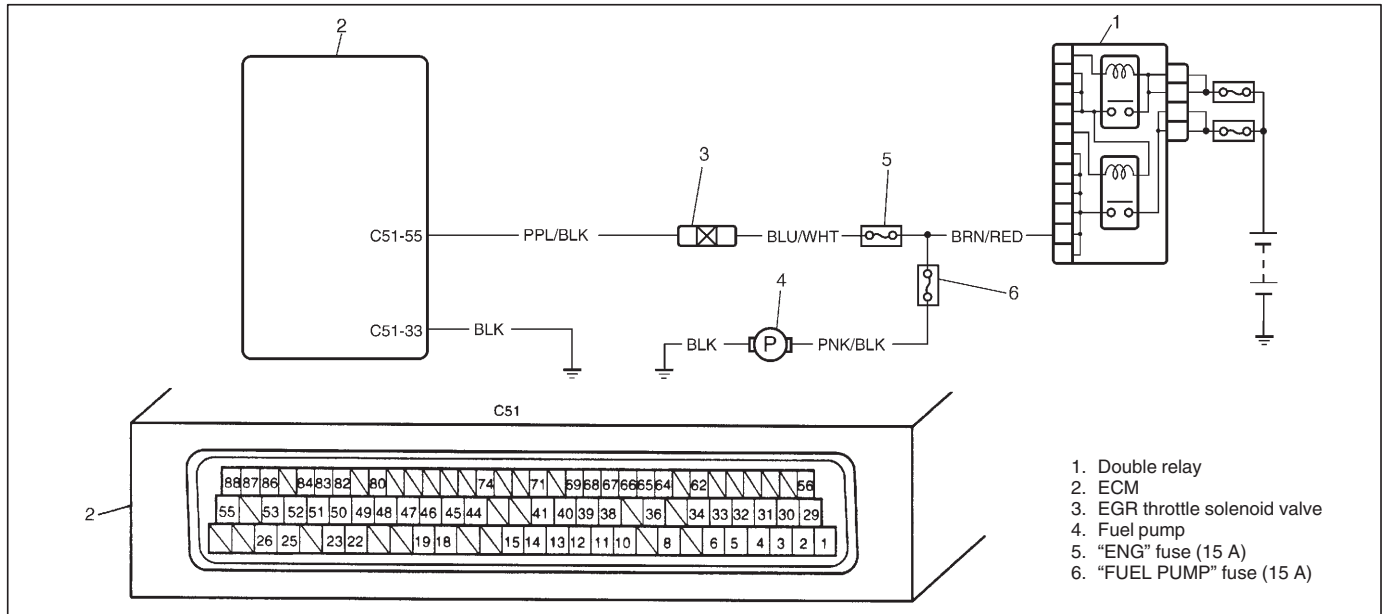

DTC CONFIRMATION PROCEDURE

- 1) Connect scan tool to DLC with ignition switch OFF.
- 2) Turn ON ignition switch and clear DTC, pending DTC and freeze frame data by using scan tool.
- 3) Turn off ignition switch and then on.
- 4) Check DTC and pending DTC by using scan tool.

TROUBLESHOOTING

STEP	ACTION	YES	NO
1	Was "ENGINE DIAG. FLOW TABLE" performed?	Go to Step 2.	Go to "ENGINE DIAG. FLOW TABLE".
2	Is operating sound heard from fuel pump?	Go to Step 3.	Proceed to DTC P0230 Diag. Flow table.
3	Check Wire Harness 1) Disconnect EGR throttle solenoid valve connector with ignition switch turned OFF. 2) With ignition switch ON, check voltage between "BLU/WHT" wire terminal of solenoid valve connector and ground. • Within 5 sec. after ignition switch ON: 10 – 14 V • Over 5 sec. after ignition switch ON: about 0 V Is check result as specified?	Go to Step 4.	"BLU/WHT" wire open, shorted to power/ground or fuse broken.
4	Check EGR Throttle Solenoid Valve 1) Check solenoid valve referring to Section 6E3. Is it in good condition?	<ul style="list-style-type: none"> • "PPL/BLK" wire open or shorted to power/ground • Poor C51-55 connection If wire and connection are OK, substitute a known-good ECM and recheck.	Faulty EGR solenoid valve.

DTC P1511 IGNITION SWITCH CIRCUIT MALFUNCTION WIRING DIAGRAM

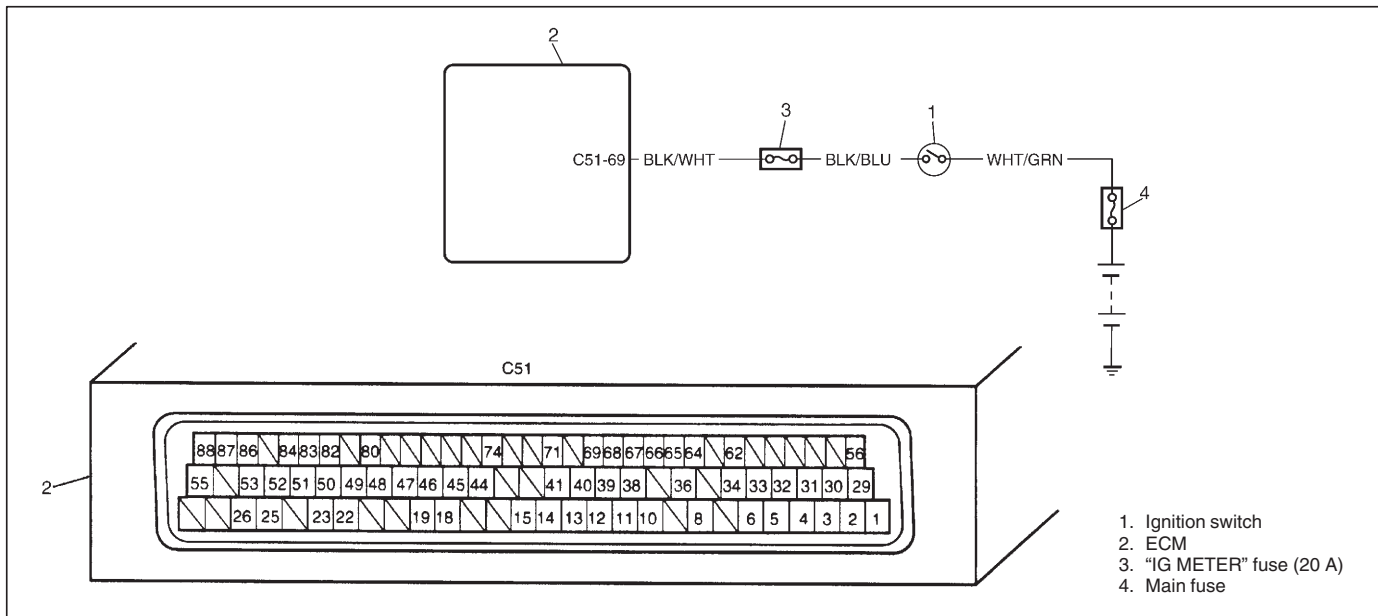

DTC CONFIRMATION PROCEDURE

- 1) Connect scan tool to DLC with ignition switch OFF.
- 2) Turn ON ignition switch and clear DTC, pending DTC and freeze frame data by using scan tool.
- 3) Turn off ignition switch and then on.
- 4) Check DTC and pending DTC by using scan tool.

TROUBLESHOOTING

STEP	ACTION	YES	NO
1	Was "ENGINE DIAG. FLOW TABLE" performed?	Go to Step 2.	Go to "ENGINE DIAG. FLOW TABLE".
2	Check Ignition Signal 1) Remove ECM cover referring to "Voltage Check" in this section. 2) Check voltage between C51-69 and ground. <ul style="list-style-type: none"> ● Ignition switch ON: 10 – 14 V ● Ignition switch OFF: 0 V Is it within specified value?	Poor C51-69 connection. If it is in good condition, substitute a known-good ECM and recheck.	"BLK/WHT" wire open or short.

DTC P1519 RADIATOR FAN CIRCUIT MALFUNCTION

WIRING DIAGRAM

Refer to DTC P1108/P1109.

TROUBLESHOOTING

Proceed to DTC P1108 and P1109 TROUBLESHOOTING.

DTC P1606 MIL CIRCUIT MALFUNCTION WIRING DIAGRAM

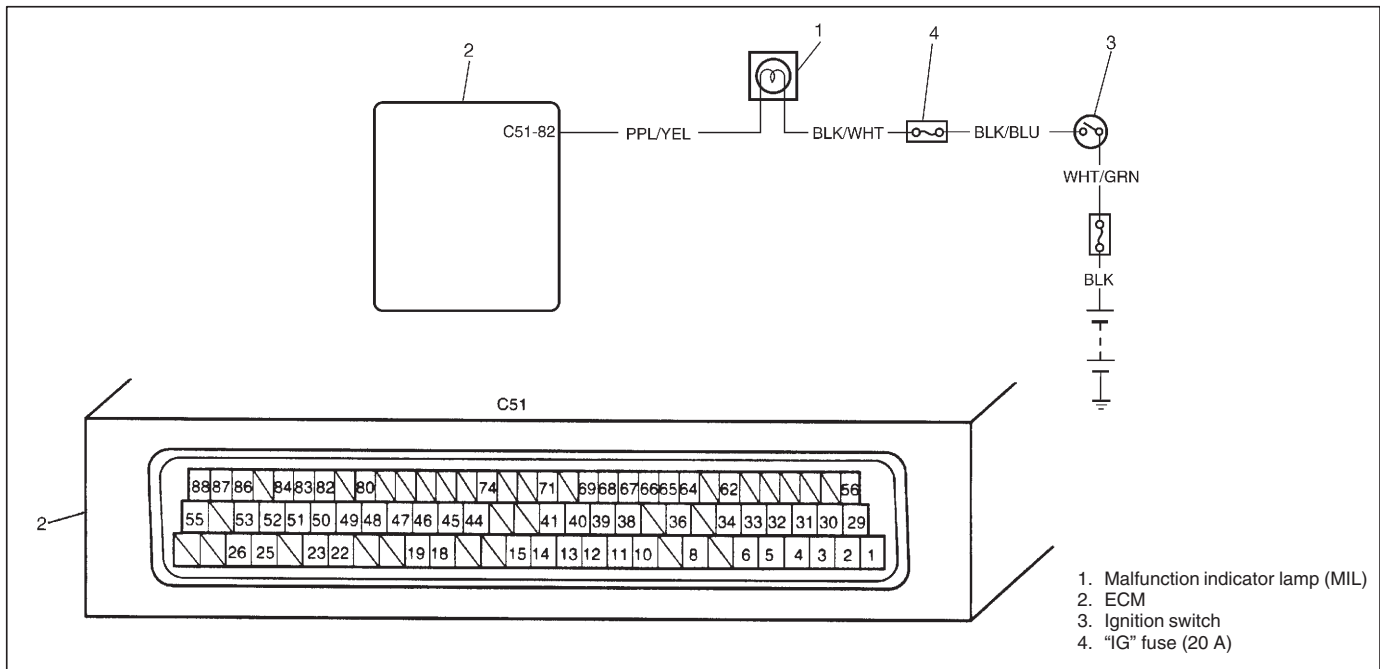

DTC CONFIRMATION PROCEDURE

- 1) Connect scan tool to DLC with ignition switch OFF.
- 2) Turn ON ignition switch and clear DTC, pending DTC and freeze frame data by using scan tool.
- 3) Turn off ignition switch and then on.
- 4) Check DTC and pending DTC by using scan tool.

TROUBLESHOOTING

STEP	ACTION	YES	NO
1	Was "ENGINE DIAG. FLOW TABLE" performed?	Go to Step 2.	Go to "ENGINE DIAG. FLOW TABLE".
2	MIL Circuit Check 1) Disconnect connector at ECM with ignition switch OFF. 2) Check voltage between "PPL/YEL" wire terminal of ECM connector and ground. ● Ignition switch ON: 10 – 14 V ● Ignition switch OFF: 0 V Is check result as specified?	Poor C51-82 connection. If it is in good condition, substitute a known-good ECM and recheck.	<ul style="list-style-type: none"> ● "PPL/YEL" wire open or short to ground/battery or ● Bulb burned out

DTC P1608 ECT WARNING LAMP CIRCUIT MALFUNCTION WIRING DIAGRAM

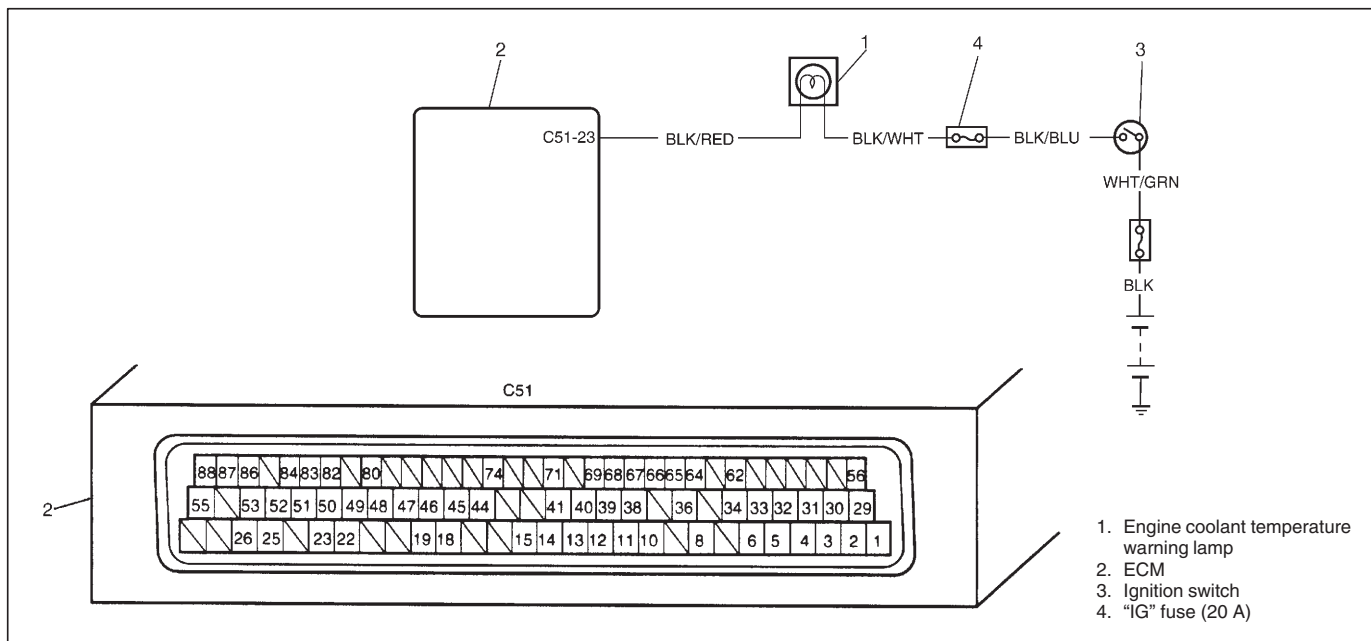

DTC CONFIRMATION PROCEDURE

- 1) Connect scan tool to DLC with ignition switch OFF.
- 2) Turn ON ignition switch and clear DTC, pending DTC and freeze frame data by using scan tool.
- 3) Turn off ignition switch and then on.
- 4) Check DTC and pending DTC by using scan tool.

TROUBLESHOOTING

STEP	ACTION	YES	NO
1	Was "ENGINE DIAG. FLOW TABLE" performed?	Go to Step 2.	Go to "ENGINE DIAG. FLOW TABLE".
2	Engine Coolant Warning Lamp Circuit Check 1) Disconnect connector at ECM with ignition switch OFF. 2) Check voltage between "BLK/RED" wire terminal of ECM connector and ground. • Ignition switch ON: 10 – 14 V • Ignition switch OFF: 0 V Is check result as specified?	Poor C51-23 connection. If it is in good condition, substitute a known-good ECM and recheck.	<ul style="list-style-type: none"> • "BLK/RED" wire open or short to ground/battery or • Bulb burned out

DTC P1614 (P0560) SENSOR SUPPLY FUNCTION WIRING DIAGRAM

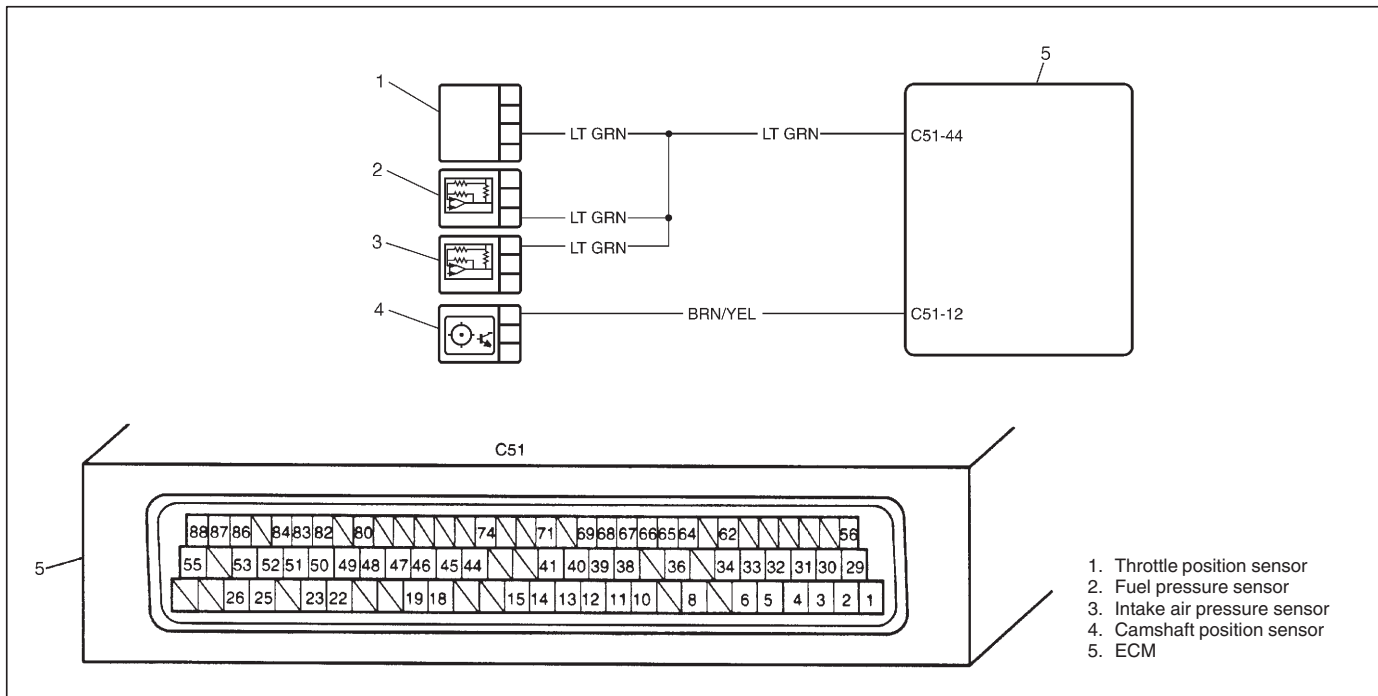

DTC CONFIRMATION PROCEDURE

- 1) Connect scan tool to DLC with ignition switch OFF.
- 2) Turn ON ignition switch and clear DTC, pending DTC and freeze frame data by using scan tool.
- 3) Check DTC and pending DTC by using scan tool.

TROUBLESHOOTING

STEP	ACTION	YES	NO
1	Was "ENGINE DIAG. FLOW TABLE" performed?	Go to Step 2.	Go to "ENGINE DIAG. FLOW TABLE".
2	"LT GRN" Circuit Check 1) Disconnect connector at intake air pressure sensor. 2) Check voltage between "LT GRN" wire terminal of connector and ground with ignition switch ON. Is it 5.1 V or more?	"LT GRN" wire short to battery.	Go to Step 3.
3	Is it 4.88 V or less?	"LT GRN" wire short to ground.	Go to Step 4.
4	"BRN/YEL" Circuit Check 1) Disconnect connector at camshaft position sensor. 2) Check voltage between "BRN/YEL" wire terminal of connector and ground with ignition switch ON. Is it 5.1 V or more?	"BRN/YEL" wire short to battery.	Go to Step 5.
5	Is it 4.88 V or less?	"BRN/YEL" wire short to ground.	Substitute a known-good ECM and recheck.

DTC P0221 (P0220) THROTTLE POSITION RANGE/PERFORMANCE PROBLEM 2**WIRING DIAGRAM**

Refer to DTC P0121.

DTC CONFIRMATION PROCEDURE

- 1) Connect scan tool to DLC with ignition switch OFF.
- 2) Turn ON ignition switch and clear DTC, pending DTC and freeze frame data by using scan tool.
- 3) Run engine at idle speed for 10 sec. or more.
- 4) Check DTC and pending DTC by using scan tool.

TROUBLESHOOTING

STEP	ACTION	YES	NO
1	Was "ENGINE DIAG. FLOW TABLE" performed?	Go to Step 2.	Go to "ENGINE DIAG. FLOW TABLE".
2	Check Sensor Power Supply Circuit 1) Connect scan tool to DLC with ignition switch OFF and then turn ignition switch ON. 2) Does scan tool indicate DTC as shown below? <Using Suzuki mode of Suzuki Scan tool> P1614 <Using Generic Scan tool or Euro mode of Suzuki Scan tool> P0560	Go to DTC P1614 (P0560) Diag. Flow Table.	Go to Step 3.
3	Check Wire Harness 1) Disconnect connector from TP sensor with ignition switch OFF. 2) Check for proper connection to TP sensor at each terminal. 3) If OK, then with ignition switch ON, check voltage between "LT GRN" wire and "BRN" wire terminals at connector of TP sensor. Is voltage about 5 V?	Go to Step 4.	"LT GRN" wire open, "BRN" wire open, poor C51-44 connection, or poor C51-22 connection. If wire and connection are OK, substitute a known-good ECM and recheck.
4	Check TP Sensor Output Voltage 1) Remove ECM cover referring to "Voltage Check" in this section. 2) With ignition switch ON, check voltage between C51-68 and ground, when accelerator pedal is at idle position to fully depressed position. Is voltage 0.2 – 1.6 V?	Substitute a known-good ECM and recheck.	"GRY/BLU" wire open, "GRY/BLU" wire shorted to ground/battery or poor TP sensor connector. If wire and connection are OK, substitute a known-good TP sensor and recheck.

**DTC P0335 (P0335) CRANKSHAFT POSITION SENSOR CIRCUIT MALFUNCTION
WIRING DIAGRAM**

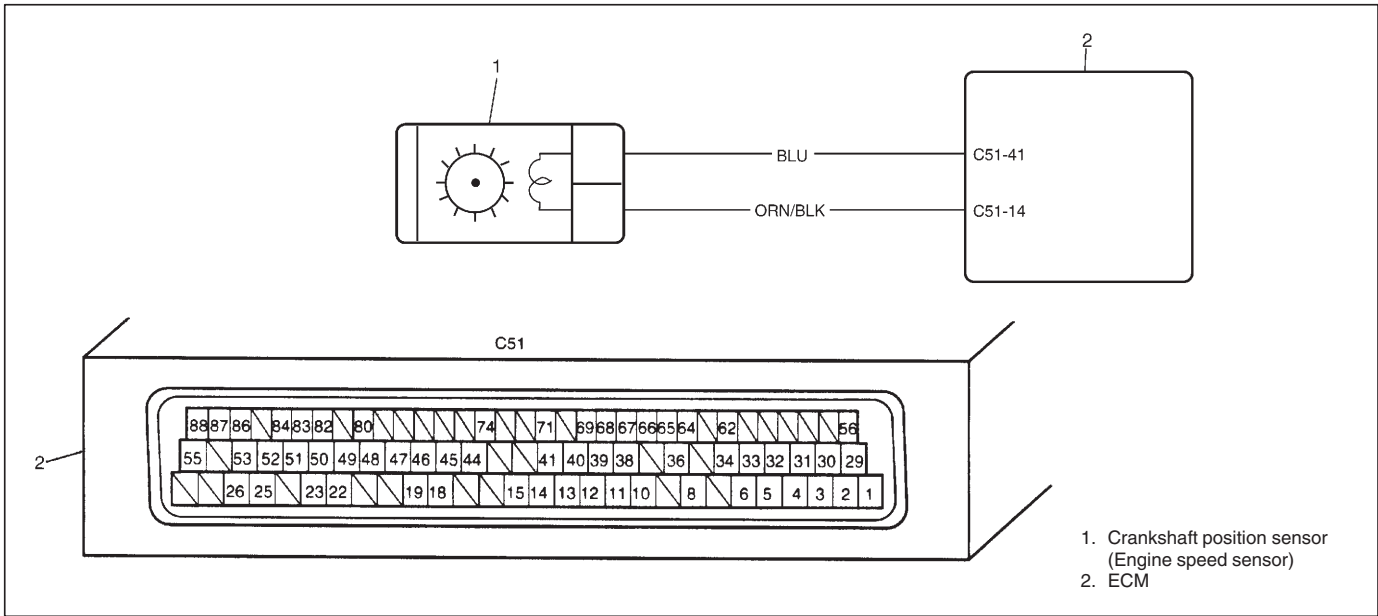

DTC CONFIRMATION PROCEDURE

- 1) Connect scan tool to DLC with ignition switch OFF.
- 2) Turn ON ignition switch and clear DTC, pending DTC and freeze frame data by using scan tool and run engine at idle speed for 10 sec.
- 3) Check DTC and pending DTC by using scan tool.

TROUBLESHOOTING

STEP	ACTION	YES	NO
1	Was "ENGINE DIAG. FLOW TABLE" performed?	Go to Step 2.	Go to "ENGINE DIAG. FLOW TABLE".
2	CKP Sensor and Its Circuit Resistance Check: 1) With ignition switch OFF, disconnect ECM coupler (C51). 2) Check for proper connection to ECM at C51-14 and C51-41 terminals. 3) If OK, check resistance of followings. Resistance between C51-14 and C51-41 terminals: 315 – 405 Ω at 20°C, 68°F Resistance between each terminal and ground: 1M Ω or more Is check result satisfactory?	Go to Step 4.	Go to Step 3.
3	CKP Sensor Resistance Check: 1) With ignition switch OFF, disconnect CKP sensor coupler and remove CKP sensor. 2) Check resistance between terminals of CKP sensor. (See Fig.) Were measured resistance values as specified in Step 2?	Faulty "ORN/BLK" wire or "BLU" wire.	Faulty CKP sensor.
4	CKP Sensor Visual Inspection: 1) Check visually CKP sensor and sensing rotor for the followings. (See Fig.) – Damage – No foreign material attached – Correct installation Are they in good condition?	Intermittent trouble or faulty ECM. Recheck for intermittent referring to "Intermittent and Poor Connection" in Section 0A. (See NOTE.)	Replace or reinstall.

NOTE:

If DTC is checked using generic scan tool only and DTC P0340 (P0335/P0340) Diag. Flow Table is not performed yet, go to the table before ECM replacement.

Fig. for Step 3

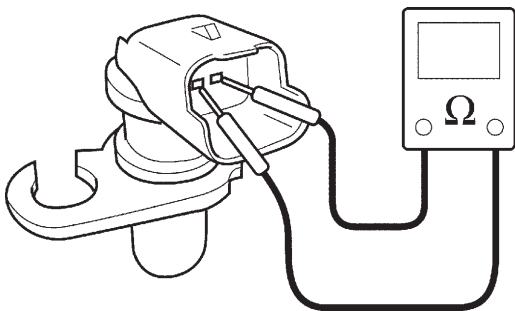

Fig. for Step 4

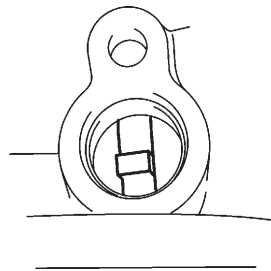
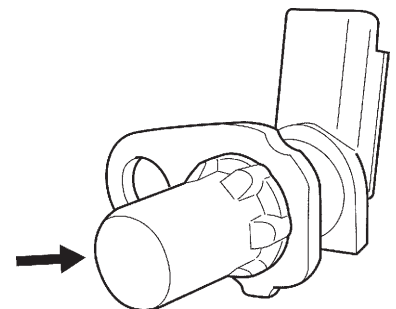
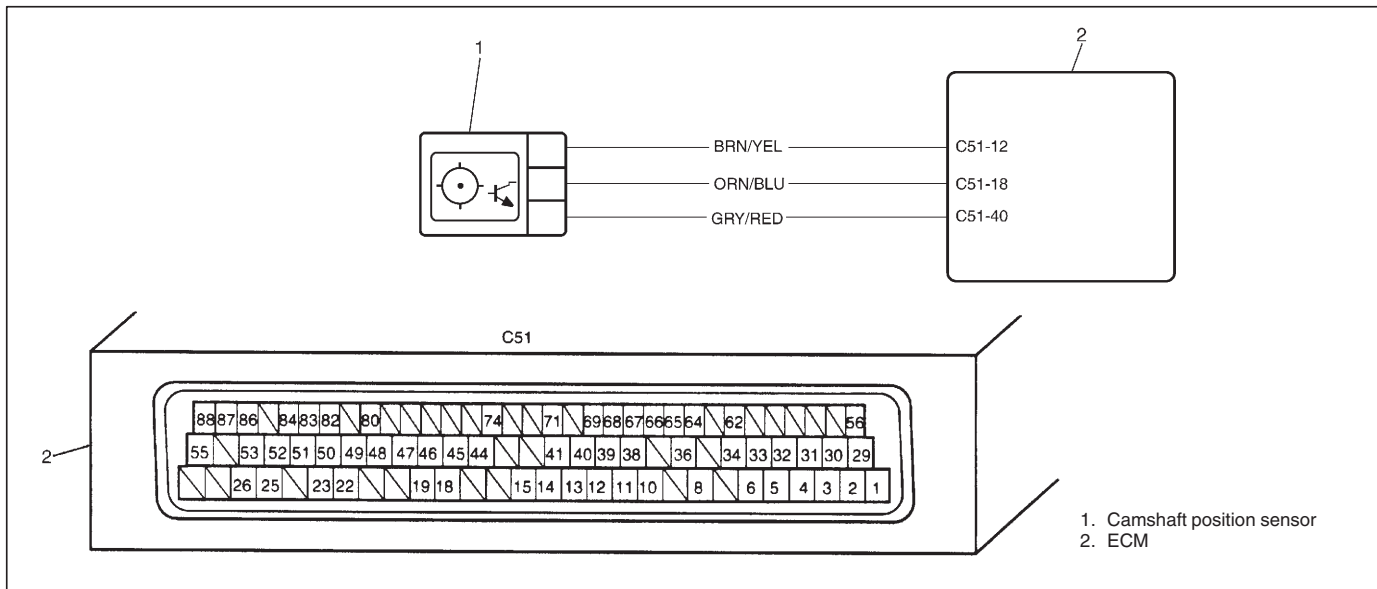

Fig. for Step 4.



DTC P0340 (P0335/P0340) CAMSHAFT POSITION SENSOR CIRCUIT MALFUNCTION WIRING DIAGRAM



DTC CONFIRMATION PROCEDURE

- 1) Connect scan tool to DLC with ignition switch OFF.
- 2) Turn ON ignition switch and clear DTC, pending DTC and freeze frame data by using scan tool.
- 3) Crank engine for 3 seconds or more and keep it at idle for 1 min. if engine start.
- 4) Check DTC and pending DTC by using scan tool.

TROUBLESHOOTING

STEP	ACTION	YES	NO
1	Was "ENGINE DIAG. FLOW TABLE" performed?	Go to Step 2.	Go to "ENGINE DIAG. FLOW TABLE".
2	Check Sensor Power Supply Circuit 1) Connect scan tool to DLC with ignition switch OFF and then turn ignition switch ON. 2) Does scan tool indicate DTC as shown below? <Using Suzuki mode of Suzuki Scan tool> P1614 <Using Generic Scan tool or Euro mode of Suzuki Scan tool> P0560	Go to DTC P1614 (P0560) Diag. Flow Table.	Go to Step 3.
3	Is engine cranked?	Go to Step 4.	Go to "CRANKING SYSTEM" section.
4	Is engine started?	Go to Step 5.	Check CKP sensor (Engine speed sensor) and its circuit according to DTC P0335 (P0335) Diag. Flow Table.
5	Check CMP Sensor and connector for proper installation. Is CMP sensor installed properly and connector connected securely?	Go to Step 6.	Correct.

STEP	ACTION	YES	NO
6	Check Wire Harness and Connection. 1) Disconnect connector from CMP sensor. 2) Check for proper connection to CMP sensor at each terminal. 3) If OK, turn ignition switch ON and check for voltage between "ORN/BLU" and "GRY/RED" terminals of sensor connector disconnected. Is voltage 10 – 14 V?	Go to Step 7.	"ORN/BLU" or "GRY/RED" wire open, short or poor connection.
7	Check for voltage between "BRN/YEL" and "GRY/RED" terminals of sensor connector disconnected. Is voltage about 5 V?	Go to Step 8.	"BRN/YEL" wire open, short or poor connection. If wire and connection are OK, substitute a known-good ECM and recheck. (See NOTE).
8	Check Camshaft Hub 1) Remove upper timing belt cover. 2) Check camshaft hub for the following. <ul style="list-style-type: none"> ● Damage ● No foreign material attached Is it in good condition?	Check CMP sensor air gap referring to Section 6E3. If check result is OK, substitute a known-good CMP sensor and recheck.	Clean surfaces of camshaft hub or replace camshaft hub.

NOTE:

If DTC is checked using generic scan tool only and DTC P0335 (P0335) Diag. Flow Table is not performed yet, go to the table before ECM replacement.

Fig. for Step 6 and 7

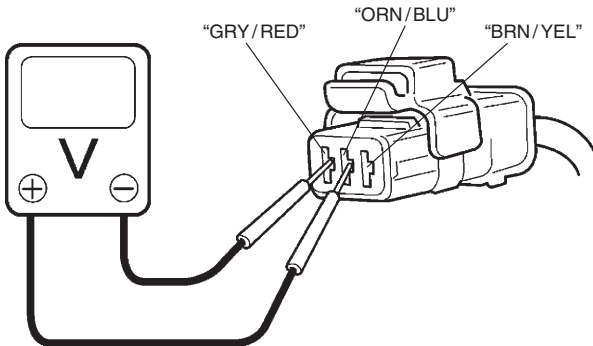

DTC P0500 (P0500) VEHICLE SPEED SENSOR CIRCUIT MALFUNCTION WIRING DIAGRAM

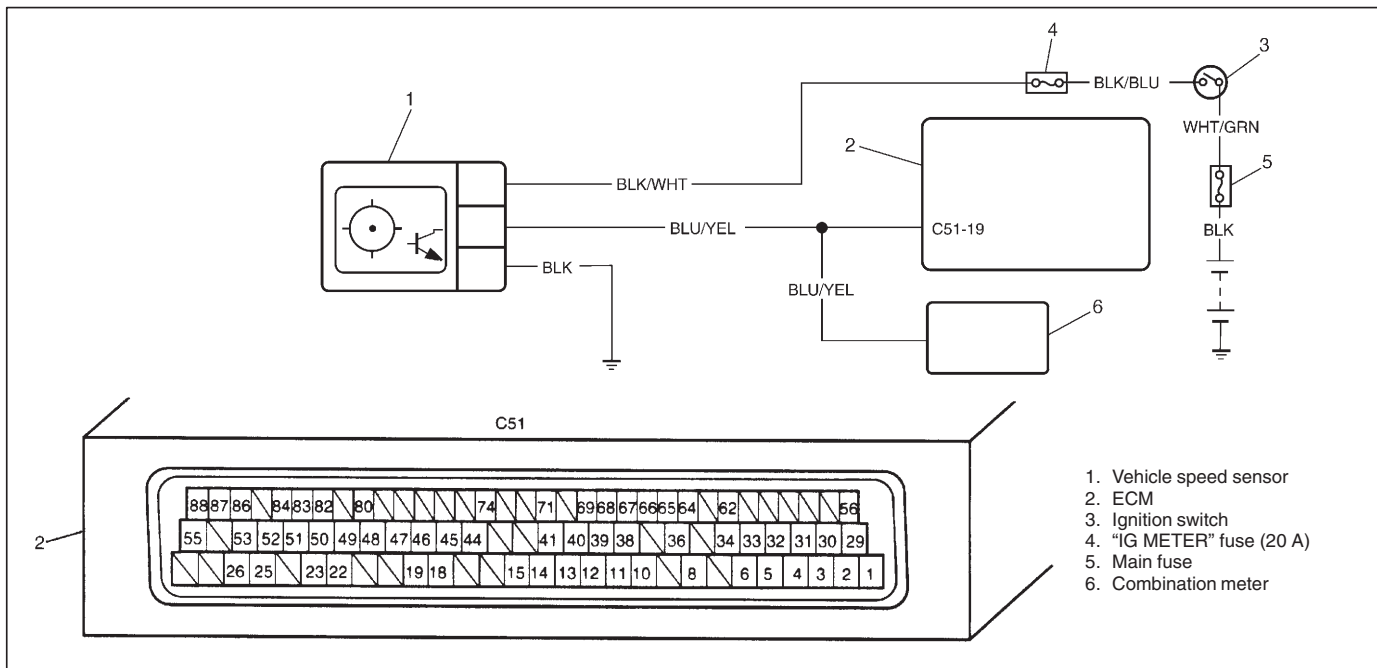

DTC CONFIRMATION PROCEDURE

WARNING:

- When performing a road test, select a place where there is no traffic or possibility of a traffic accident and be very careful during testing to avoid occurrence of an accident.
- Road test should be carried out with 2 persons, a driver and a tester, on a level road.

- 1) Connect scan tool to DLC with ignition switch OFF.
- 2) Turn ON ignition switch and clear DTC, pending DTC and freeze frame data by using scan tool and warm up engine completely.
- 3) Increase vehicle speed to 100 – 110 km/h (60 – 70 mph).
- 4) Release accelerator pedal and with engine brake applied, keep vehicle coasting and then stop vehicle.
- 5) Check DTC and pending DTC by using scan tool.

TROUBLESHOOTING

STEP	ACTION	YES	NO
1	Was "ENGINE DIAG. FLOW TABLE" performed?	Go to Step 2.	Go to "ENGINE DIAG. FLOW TABLE".
2	Does speedometer indicate vehicle speed?	Faulty "BLU/YEL" wire or poor C51-19 connection. If wire and connection are OK, intermittent trouble or faulty ECM. Check for intermittent referring to "Intermittent and Poor Connection" in Section 0A.	Go to Step 3.
3	VSS Power Supply Voltage Check: 1) With ignition switch OFF, remove VSS coupler. 2) With ignition switch ON leaving engine OFF, check voltage between "BLK/WHT" wire terminal and "BLK" wire terminal of VSS coupler. Is voltage 10 – 14 V?	Go to Step 4.	"BLK/WHT" or "BLK" wire open/short.
4	VSS Signal Harness Check: 1) With ignition switch ON leaving engine OFF, check voltage between "BLU/YEL" wire terminal and "BLK" wire terminal of VSS coupler. Is voltage 4 V or more?	Go to Step 5.	Go to Step 6.
5	VSS Visual Inspection: 1) Remove VSS referring to "TRANSFER" section. 2) Check VSS drive and driven gears for damage and excessive wear. Are they in good condition?	Poor VSS connection or VSS malfunction. If connection is OK, substitute a known-good VSS and recheck.	Replace VSS.
6	Speedometer Circuit Check: 1) With ignition switch OFF, disconnect G11 coupler from combination meter. 2) With ignition switch ON leaving engine OFF, check voltage between "BLU/YEL" wire terminal and "BLK" wire terminal of VSS coupler. Is voltage 4 V or more?	Substitute a known-good combination meter and recheck.	"BLU/YEL" wire open/short or faulty ECM. If wire and connection are OK, substitute a known-good ECM and recheck.

DTC P0235 (P0235) INTAKE AIR PRESSURE SENSOR CIRCUIT MALFUNCTION WIRING DIAGRAM

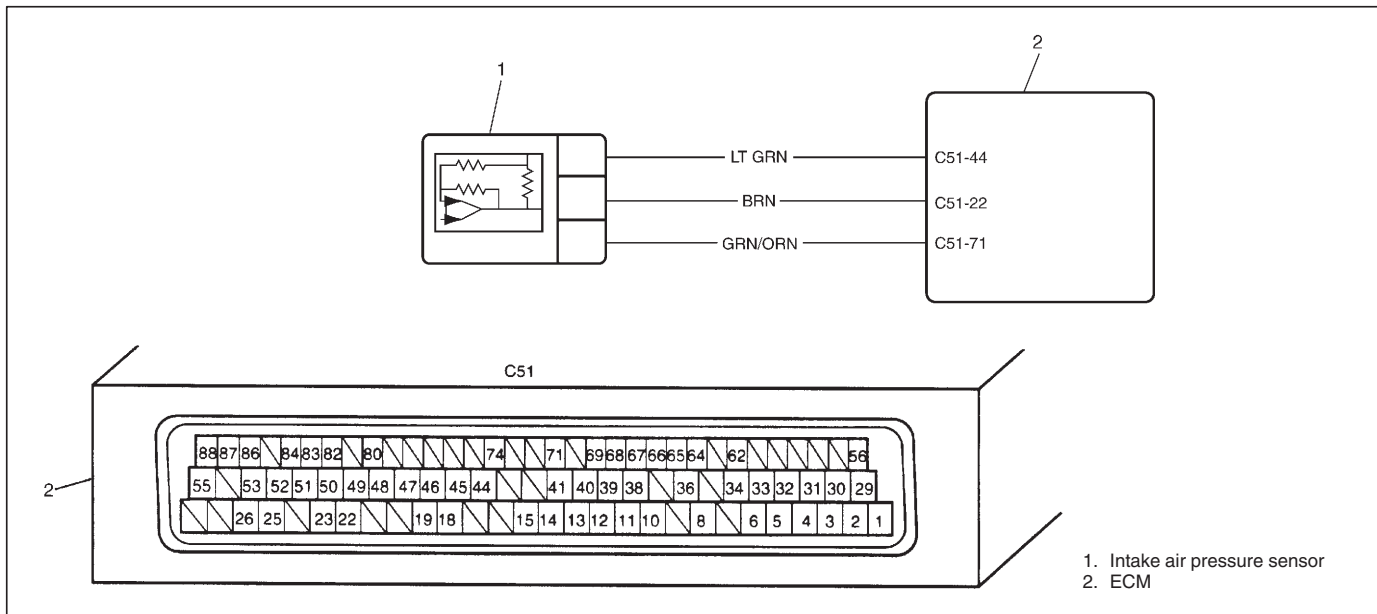

DTC CONFIRMATION PROCEDURE

WARNING:

- When performing a road test, select a place where there is no traffic or possibility of a traffic accident and be very careful during testing to avoid occurrence of an accident.
- Road test should be carried out with 2 persons, a driver and a tester, on a level road.

NOTE:

Check to make sure that the following conditions are satisfied when using this DTC CONFIRMATION PROCEDURE.

- Intake air temp.: 5°C, 41°F or higher
- Engine coolant temp.: -8 – 110°C (18 – 230°F)
- Altitude (barometric pressure): 2400 m, 8000 ft or less (560 mmHg, 75 kPa or more)

- 1) Connect scan tool to DLC with ignition switch OFF.
- 2) Turn ON ignition switch and clear DTC, pending DTC and freeze frame data by using scan tool.
- 3) Run engine at idle speed for 10 sec or more.
- 4) Check DTC and pending DTC by using scan tool.

TROUBLESHOOTING

STEP	ACTION	YES	NO
1	Was "ENGINE DIAG. FLOW TABLE" performed?	Go to Step 2.	Go to "ENGINE DIAG. FLOW TABLE".
2	<p>Check Sensor Power Supply Circuit</p> <p>1) Connect scan tool to DLC with ignition switch OFF and then turn ignition switch ON.</p> <p>2) Does scan tool indicate DTC as shown below?</p> <p><Using Suzuki mode of Suzuki Scan tool> P1614</p> <p><Using Generic Scan tool or Euro mode of Suzuki Scan tool> P0560</p>	Go to DTC P1614 (P0560) Diag. Flow Table.	Go to Step 3.
3	<p>Intake Air Pressure Sensor Signal Check:</p> <p>1) Remove ECM cover referring to "Voltage Check" in this section.</p> <p>2) Check voltage C51-71 and ground with ignition switch ON.</p> <p>Is it between 1 and 5 V?</p>	Intermittent trouble or faulty ECM. Check for intermittent referring to "Intermittent and Poor Connection" in Section 0A.	Go to Step 4.
4	<p>Intake Air Pressure Sensor Check:</p> <p>1) Disconnect connector from intake air pressure sensor.</p> <p>2) Check for proper connection to intake air pressure sensor at each terminal.</p> <p>3) If OK, check intake air pressure sensor for performance referring to "Intake Air Pressure Sensor Inspection" in Section 6E3.</p> <p>Is check result satisfactory?</p>	"LT GRN", "BRN" or "GRN/ORN" circuit open/short. If wire and connections are OK, substitute a known-good ECM and recheck.	Replace intake air pressure sensor.

DTC P0560 (P0560) POWER SUPPLY CIRCUIT MALFUNCTION

WIRING DIAGRAM

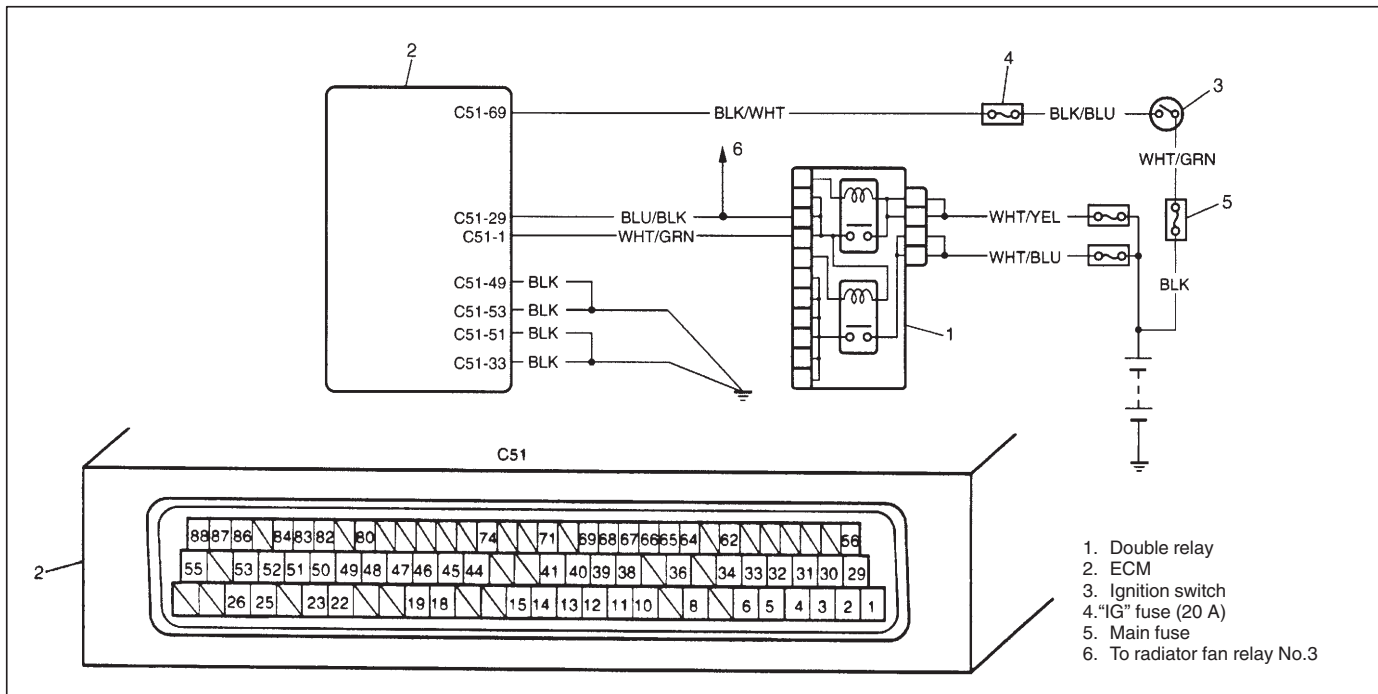

DTC CONFIRMATION PROCEDURE

- 1) Connect scan tool to DLC with ignition switch OFF.
- 2) Turn ON ignition switch and clear DTC/pending DTC and freeze frame data by using scan tool and run engine at idle speed for 1 min.
- 3) Check DTC and pending DTC by using scan tool.

TROUBLESHOOTING (DTC P1500)

STEP	ACTION	YES	NO
1	Was "ENGINE DIAG. FLOW TABLE" performed?	Go to Step 2.	Go to "ENGINE DIAG. FLOW TABLE".
2	1) Remove ECM cover referring to "Voltage Check" in this section. 2) While engine running, check voltage between following terminals. C51-69 and ground C51-29 and ground C51-1 and ground Is each voltage between 7 and 17.5 V?	Intermittent trouble. Check for intermittent referring to "INTERMITTENT AND POOR CONNECTION" in Section 0A. If wire and connections are OK, substitute a known-good ECM and recheck. (See NOTE.)	"BLK/WHT", "BLU/BLK" or "WHT/GRN" circuit open or short.

NOTE:

If DTC is checked using generic scan tool only and P1614 (P0560) Diag. Flow Table is not performed yet, go to the table before ECM replacement.

TABLE B-1 FUEL PUMP CIRCUIT INSPECTION WIRING DIAGRAM

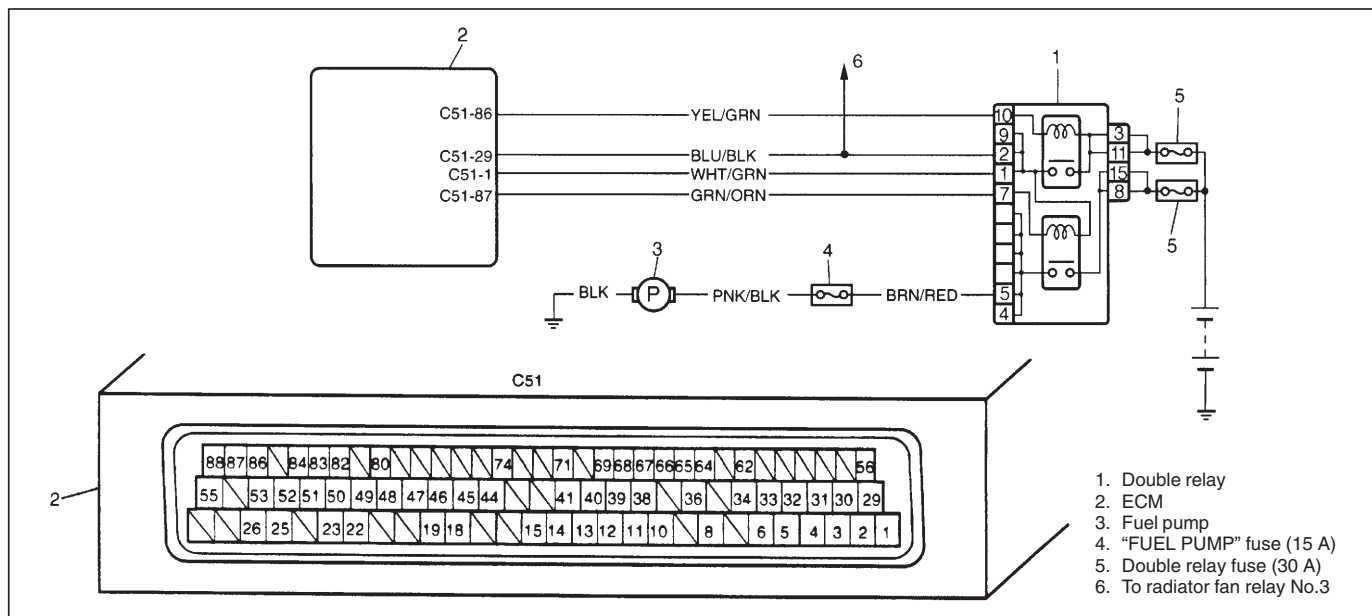

INSPECTION

STEP	ACTION	YES	NO
1	Fuel Pump Operation Check: 1) Turn ON ignition switch. Is fuel pump operation sound heard for 5 sec. after ignition switch ON?	Fuel pump circuit is in good condition.	Go to Step 2.
2	Fuel Pump Circuit Check: 1) With ignition switch OFF, remove double relay from connector. 2) Check for proper connection to relay at each terminal. 3) If OK, using service wire, connect terminals 8 and 5 of relay connector. CAUTION: Check to make sure that connection is made between correct terminals. Wrong connection can cause damage to ECM, wire harness etc. Is fuel pump heard to operate at ignition switch ON?	Go to Step 3.	"BLK", "PNK/BLK" or "BRN/RED" circuit open or fuel pump malfunction.
3	Double Relay Check: 1) Check fuel pump relay referring to "Double Relay Inspection" in Section 6E3. Is it in good condition?	"GRN/ORN" circuit open.	Replace fuel pump.

**TABLE B-2 FUEL PRESSURE INSPECTION
SYSTEM DIAGRAM**

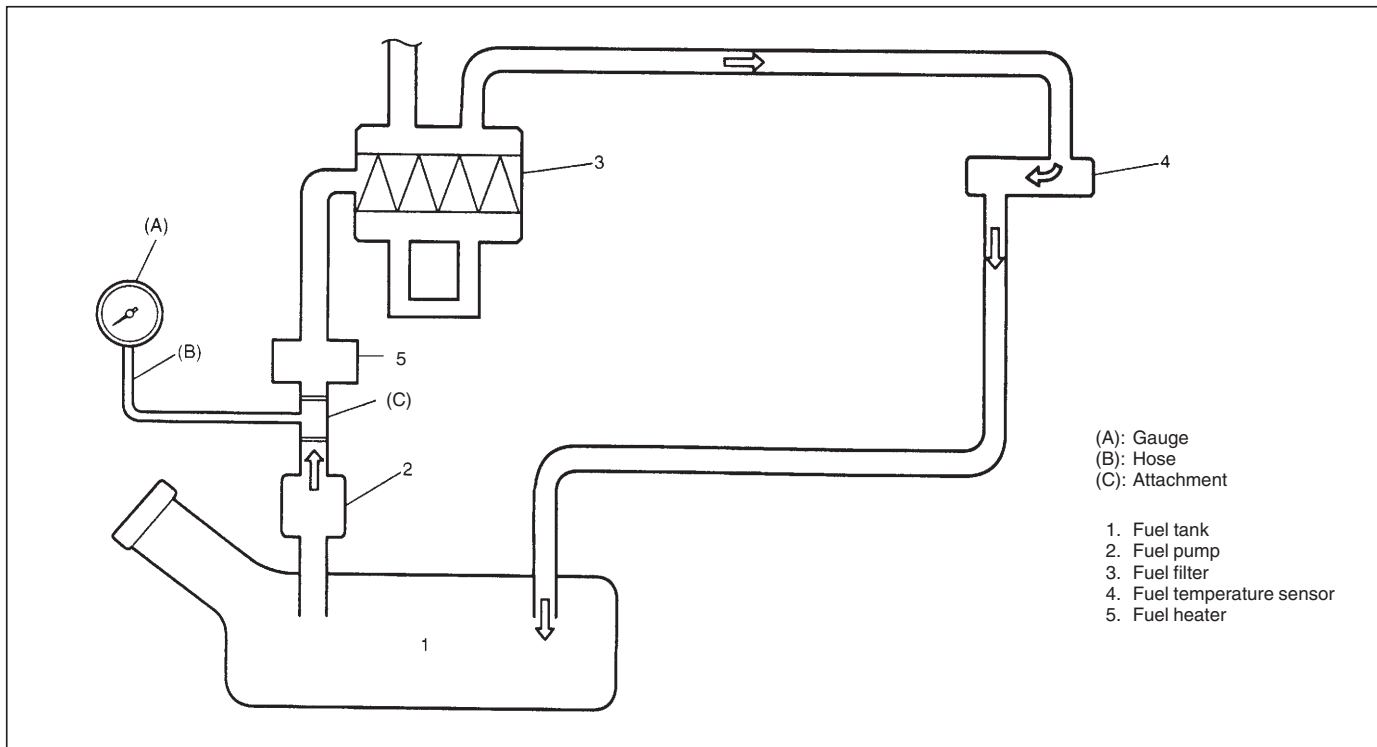

INSPECTION

NOTE:

Before using following flow table, check to make sure that battery voltage is higher than 11 V. If battery voltage is low, pressure becomes lower than specification even if fuel pump and line are in good condition.

STEP	ACTION	YES	NO
1	1) Install fuel pressure gauge, referring to "Low Pressure Fuel Supply System Inspection" in Section 6E3. 2) Operate fuel pump. Is fuel pressure then about 220 kPa (2.2 kg/cm ² , 31.3 psi)?	Normal fuel pressure.	Go to Step 2.
2	Was fuel pressure higher than spec. in Step 1?	Clogged fuel heater, fuel filter fuel temperature or fuel hose/pipe.	Go to Step 3.
3	Was no fuel pressure applied in Step 1?	<ul style="list-style-type: none"> ● Shortage of fuel or ● Fuel pump and its circuit defective. (Refer to Table B-1 "Fuel Pump Circuit Inspection".)	Fuel leakage from fuel line.

SPECIAL TOOLS

			<ol style="list-style-type: none"> 1. Pressure gauge 09912-58441 2. Pressure hose 09912-58431 3. Attachment 09919-46010 4. Checking tool set 09912-58421 <ol style="list-style-type: none"> 4-1. Tool body & washer 4-2. Body plug 4-3. Body attachment 4-4. Holder 4-5. Return hose & clamp 4-6. Body attachment-2 & washer 4-7. Hose attachment-1 4-8. Hose attachment-2
<p>09931-76011 Tech 1A kit (SUZUKI scan tool) See NOTE "A" below.</p>	<p>09931-76030 16/14 pin DLC cable</p>	<p>Mass storage cartridge of version 1.7 or more for Tech 1A</p>	<p>Tech 2 kit (SUZUKI scan tool) See NOTE "B" below.</p>

NOTE:

- "A": This kit includes the following items and substitutes for the Tech 2 kit.
 1. Storage case, 2. Operator's manual, 3. Tech 1A, 4. DLC cable, 5. Test lead/probe, 6. Power source cable, 7. DLC cable adaptor, 8. Self-test adaptor
- "B": This kit includes the following items and substitutes for the Tech 1 kit.
 1. Tech 2, 2. PCMCIA card, 3. DLC cable, 4. SAE16/19 adapter, 5. Cigarette cable, 6. DLC loopback adapter, 7. Battery power cable, 8. RS232 cable, 9. RS232 adapter, 10. RS232 loopback connector, 11. Storage case, 12. Power supply

SECTION 6-1

ENGINE GENERAL INFORMATION AND DIAGNOSIS

(RHZ ENGINE WITH TRIPLE-CONNECTOR ECM)

WARNING:

For vehicles equipped with Supplemental Restraint (Air Bag) System:

- Service on and around the air bag system components or wiring must be performed only by an authorized SUZUKI dealer. Refer to “Air Bag System Components and Wiring Location View” under “General Description” in air bag system section in order to confirm whether you are performing service on or near the air bag system components or wiring. Please observe all WARNINGS and “Service Precautions” under “On-Vehicle Service” in air bag system section before performing service on or around the air bag system components or wiring. Failure to follow WARNINGS could result in unintentional activation of the system or could render the system inoperative. Either of these two conditions may result in severe injury.
- Technical service work must be started at least 90 seconds after the ignition switch is turned to the “LOCK” position and the negative cable is disconnected from the battery. Otherwise, the system may be activated by reserve energy in the Sensing and Diagnostic Module (SDM).

6-1

CONTENTS

GENERAL INFORMATION	6-1- 3	Table A-2 MIL Circuit Check (MIL remains ON)	6-1- 8
ENGINE DIAGNOSIS	6-1- 3	Table A-3 ECM (PCM) Power and Ground Circuit Check	6-1- 8
General Description	6-1- 3	DTC P0100 (DTC P0100) MAF Circuit Malfunction	6-1-10
On-Board Diagnosis	6-1- 3	DTC P0101 (P0100) MAF Sensor Circuit Range/Performance Problem	6-1-12
Precaution in Diagnosing Trouble	6-1- 3	DTC P0110 IAT Circuit Malfunction	6-1-13
Engine Diagnostic Flow Table	6-1- 3	DTC P0115 (DTC P0115) Engine Coolant Temp. Sensor Circuit Malfunction	6-1-15
Customer Problem Inspection Form	6-1- 3	DTC P0121 (DTC P0120) TP Circuit Range/Performance Problem	6-1-16
Malfunction Indicator Lamp (MIL) Check	6-1- 3	DTC P0604 (P0120) TP Sensor Monitoring System Malfunction	6-1-16
Diagnostic Trouble Code (DTC) Check	6-1- 3	DTC P0180 Fuel Temp. Sensor Circuit Malfunction	6-1-18
Diagnostic Trouble Code (DTC) Clearance	6-1- 3	DTC P0190 (P0190) Fuel Rail Pressure Sensor Circuit Malfunction	6-1-19
Fail-Safe Table	6-1- 3	DTC P0191 (P0230) Fuel Rail Pressure Sensor/Pressure Regulator Consistency Function	6-1-21
Diagnostic Trouble Code (DTC) Table ...	6-1- 3		
Visual Inspection	6-1- 3		
Engine Basic Check	6-1- 3		
Engine Diagnosis Table	6-1- 3		
Inspection of PCM (ECM) and Its Circuits	6-1- 4		
Voltage Check	6-1- 4		
Resistance Check	6-1- 6		
Table A-1 MIL Circuit Check (MIL does not come ON)	6-1- 7		

DTC P1112 (P0230) Fuel Pressure Monitoring Circuit Malfunction	6-1-21	DTC P1108 Radiator Fan High Speed Circuit Malfunction	6-1-35
DTC P0201 (P0200) Injector Circuit Malfunction Cylinder 1	6-1-23	DTC P1109 Radiator Fan Low Speed Circuit Malfunction	6-1-36
DTC P0202 (P0200) Injector Circuit Malfunction Cylinder 2	6-1-23	DTC P1110 A/C Signal Circuit Malfunction	6-1-37
DTC P0203 (P0200) Injector Circuit Malfunction Cylinder 3	6-1-23	DTC P1135 3rd Piston Deactivator Circuit Malfunction	6-1-38
DTC P0204 (P0200) Injector Circuit Malfunction Cylinder 4	6-1-23	DTC P1138 (P0230) Fuel Pressure Regulator Circuit Malfunction	6-1-39
DTC P0215 Double Relay Circuit Malfunction	6-1-25	DTC P1402 (P0510) Throttle Solenoid Valve Circuit Malfunction	6-1-40
DTC P0230 Fuel Pump Supply Circuit Malfunction	6-1-26	DTC P1511 Ignition Switch Circuit Malfunction	6-1-41
DTC P0243 (P0243) Turbo Pressure Solenoid Valve Circuit Range/Performance Problem	6-1-27	DTC P1519 Radiator Fan Circuit Malfunction	6-1-42
DTC P0245 (P0243/P0246 (P0243) Turbo Pressure Solenoid Valve Circuit Range/Performance Problem	6-1-29	DTC P1606 MIL Circuit Malfunction	6-1-43
DTC P0380 (P0380) Pre/Post Heat Relay Circuit Malfunction	6-1-30	DTC P1608 ECT Warning Lamp Circuit Malfunction	6-1-44
DTC P0381 Glow Indicator Lamp Circuit Malfunction	6-1-31	DTC P1614 (P0560) Sensor Supply Function	6-1-45
DTC P0401 (P0903) EGR Solenoid Valve Flow Insufficient Defected	6-1-32	DTC P0221 (P0220) TP Range/Performance Problem	6-1-47
DTC P0402 (P0903) EGR Solenoid Valve Flow Excessive Detected	6-1-32	DTC P0335 (P0335) CKP Sensor Circuit Malfunction	6-1-48
DTC P0403 (P0403) EGR Solenoid Valve Circuit Malfunction	6-1-33	DTC P0340 (P0335/P0340) CMP Sensor Circuit Malfunction	6-1-50
DTC P0561 Stabilization of Sensor Supply	6-1-34	DTC P0500 (P0500) Vehicle Speed Sensor Circuit Malfunction	6-1-52
DTC P0603/P0606!!G/P1171/P1617 ECM Function	6-1-34	DTC P0235 (P0235) Intake Air Pressure Sensor Circuit Malfunction	6-1-54
DTC P1169 (P0170) Condenser Voltage Function 1	6-1-34	DTC P0560 (P0560) Power Supply Circuit Malfunction	6-1-56
DTC P1170 (P0170) Condenser Voltage Function 2	6-1-34	Table B-1 Fuel Pump Circuit Inspection	6-1-57
DTC P1101 (P0105) Barometric Pressure Sensor Circuit Malfunction	6-1-34	Table B-2 Fuel Pressure Inspection	6-1-58
		SPECIAL TOOLS	6-1-59

GENERAL INFORMATION

Refer to "SECTION 6" in this manual.

ENGINE DIAGNOSIS

GENERAL DESCRIPTION

Refer to "SECTION 6" in this manual.

ON-BOARD DIAGNOSIS

Refer to "SECTION 6" in this manual.

PRECAUTION IN DIAGNOSING TROUBLE

Refer to "SECTION 6" in this manual.

ENGINE DIAGNOSTIC FLOW TABLE

Refer to "SECTION 6" in this manual.

CUSTOMER PROBLEM INSPECTION FORM

Refer to "SECTION 6" in this manual.

MALFUNCTION INDICATOR LAMP (MIL) CHECK

Refer to "SECTION 6" in this manual.

DIAGNOSTIC TROUBLE CODE (DTC) CHECK

Refer to "SECTION 6" in this manual.

DIAGNOSTIC TROUBLE CODE (DTC) CLEARANCE

Refer to "SECTION 6" in this manual.

FAIL-SAFE TABLE

Refer to "SECTION 6" in this manual.

DIAGNOSTIC TROUBLE CODE (DTC) TABLE

Refer to "SECTION 6" in this manual.

VISUAL INSPECTION

Refer to "SECTION 6" in this manual.

ENGINE BASIC CHECK

Refer to "SECTION 6" in this manual.

ENGINE DIAGNOSIS TABLE

Refer to "SECTION 6" in this manual.

INSPECTION OF PCM (ECM) AND ITS CIRCUITS

PCM (ECM) and its circuits can be checked at PCM (ECM) wiring couplers by measuring voltage and resistance.

CAUTION:

PCM/ECM cannot be checked by itself. It is strictly prohibited to connect voltmeter or ohmmeter to PCM (ECM) with couplers disconnected from it.

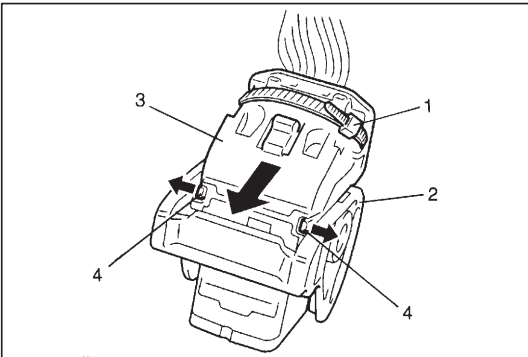

Voltage Check

- 1) Remove ECM from ECM bracket referring to "ENGINE CONTROL MODULE (ECM)" in Section 6E3.
- 2) Remove harness clamps (1) from ECM harness connector assemblies (2).
- 3) Remove connector covers (3) from ECM harness connector assemblies loosening connector cover locks (4).

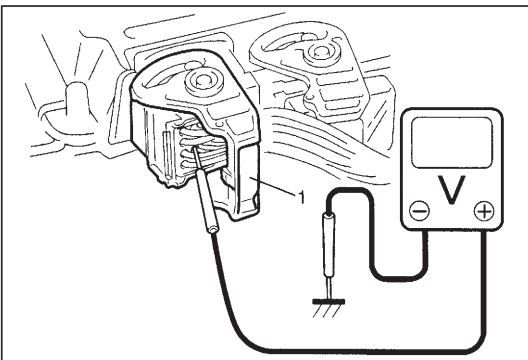

- 4) Connect ECM harness connectors to ECM using connector lock lever (1).
- 5) Measure voltage at each terminal with ignition switch turned ON according to Diag. Flow Table.

NOTE:

As each terminal voltage is affected by the battery voltage, confirm that it is 11 V or more when ignition switch is ON.

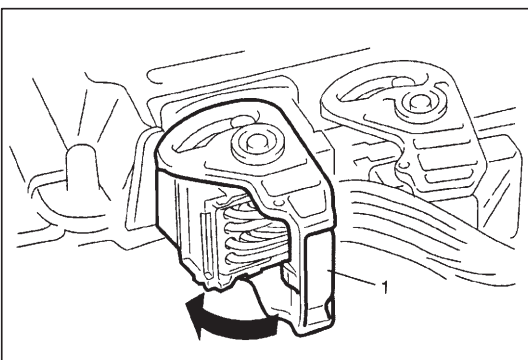

- 6) After measuring, disconnect ECM harness connectors (1) from ECM loosening connector lock lever.

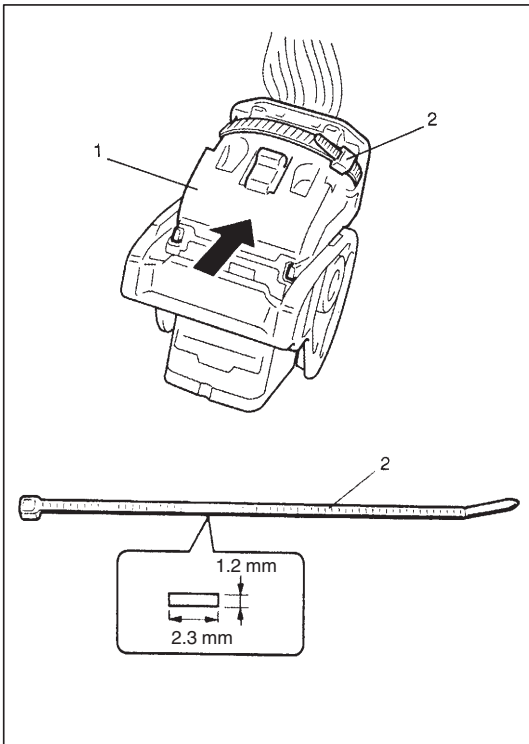

- 7) Install connector covers (1) to ECM harness connectors securely.
- 8) Tighten harness clamps (2) with ECM harness and ECM harness connector securely.
- 9) Connect ECM connector assemblies to ECM using connector lock lever securely.

NOTE:

When clamp replacement is necessary, be sure to use a clamp with width and thickness as specified below or less. If a larger clamp is used, lock lever will be caught by clamp and it will be impossible to install ECM connector to ECM.

Width: 2.3 mm Thickness: 1.2 mm

- 10) Install ECM to bracket referring to "ENGINE CONTROL MODULE" in Section 6E3.

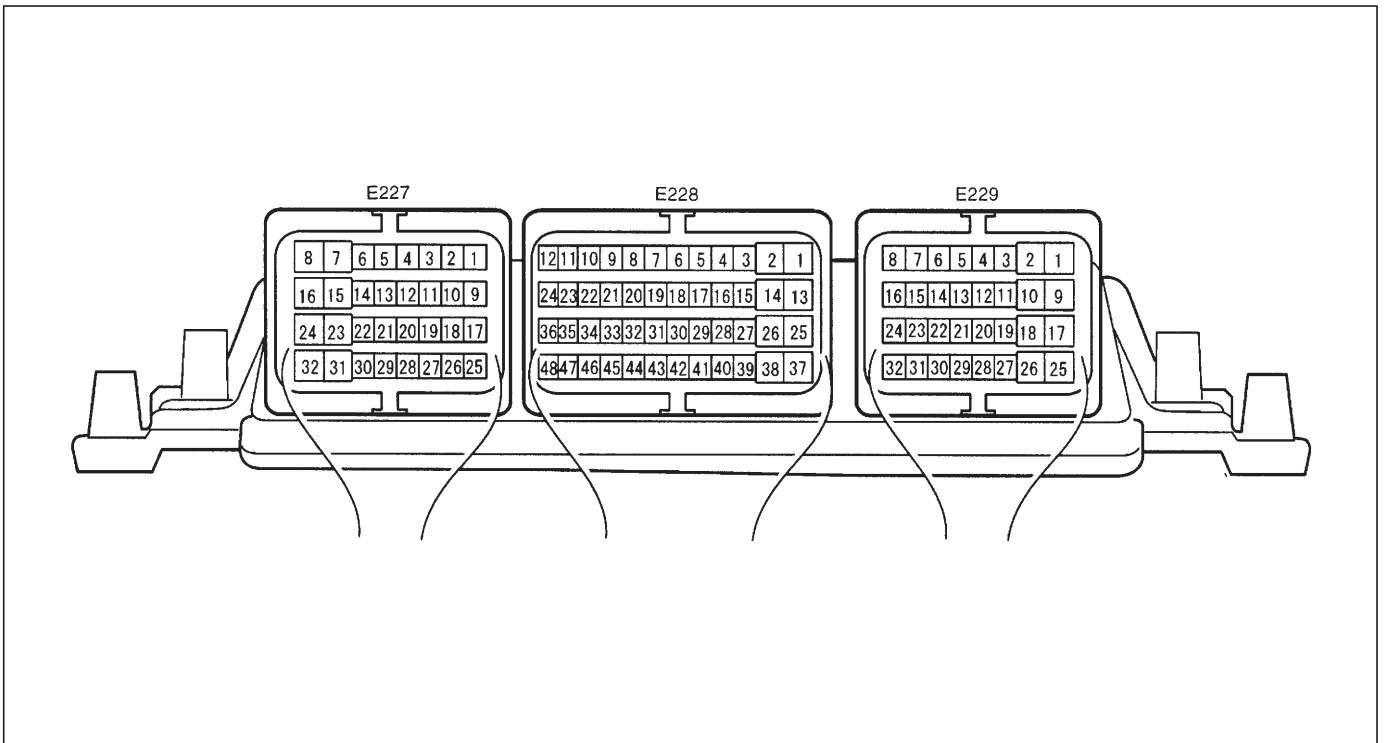

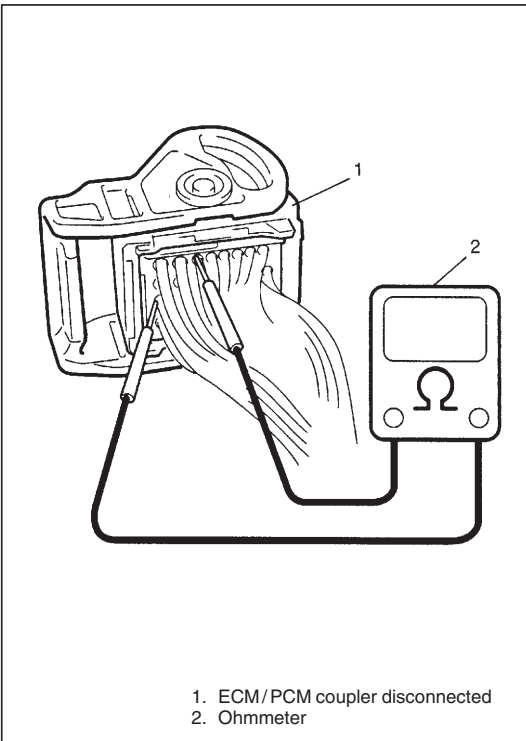

Resistance Check

- 1) Disconnect couplers from ECM/PCM with ignition switch OFF.

CAUTION:

Do not touch terminals of ECM/PCM itself or connect voltmeter or ohmmeter.

- 2) Check resistance between each pair of terminals of disconnected couplers as listed in the following table.

CAUTION:

- Be sure to connect ohmmeter probe from wire harness side of coupler.
- Be sure to turn OFF ignition switch for this check.
- Resistance in table represents that when parts temperature is 20°C (68°F).

TERMINAL	CIRCUIT	STANDARD RESISTANCE	CONDITION
E229-2 to E229-9	Fuel injector No.1	Max. 0.6 Ω	—
E229-25 to E229-17	Fuel injector No.2	Max. 0.6 Ω	—
E229-26 to E229-18	Fuel injector No.3	Max. 0.6 Ω	—
E229-1 to E229-10	Fuel injector No.4	Max. 0.6 Ω	—
E228-4 to E228-3	CKP sensor	315 – 405 Ω	At 20°C (68°F)
E228-21 to E228-20	Fuel temp. sensor	Refer to "FUEL TEMPERATURE SENSOR" in Section 6E3.	
E228-1 to E228-14	Fuel pressure regulator	2 – 3 Ω	At 20°C (68°F)
E228-8 to E228-9	ECT sensor	Refer to "ECT SENSOR" in Section 6E3.	
E228-37 to Body ground	Ground	Below 1.5 Ω	—
E228-38 to Body ground	Ground	Below 1.5 Ω	—
E227-32 to Body ground	Ground	Below 1.5 Ω	—

TABLE A-1 MALFUNCTION INDICATOR LAMP CIRCUIT CHECK – MIL DOES NOT COME “ON” OR DIMS AT IGNITION SWITCH ON (BUT ENGINE AT STOP)

WIRING DIAGRAM

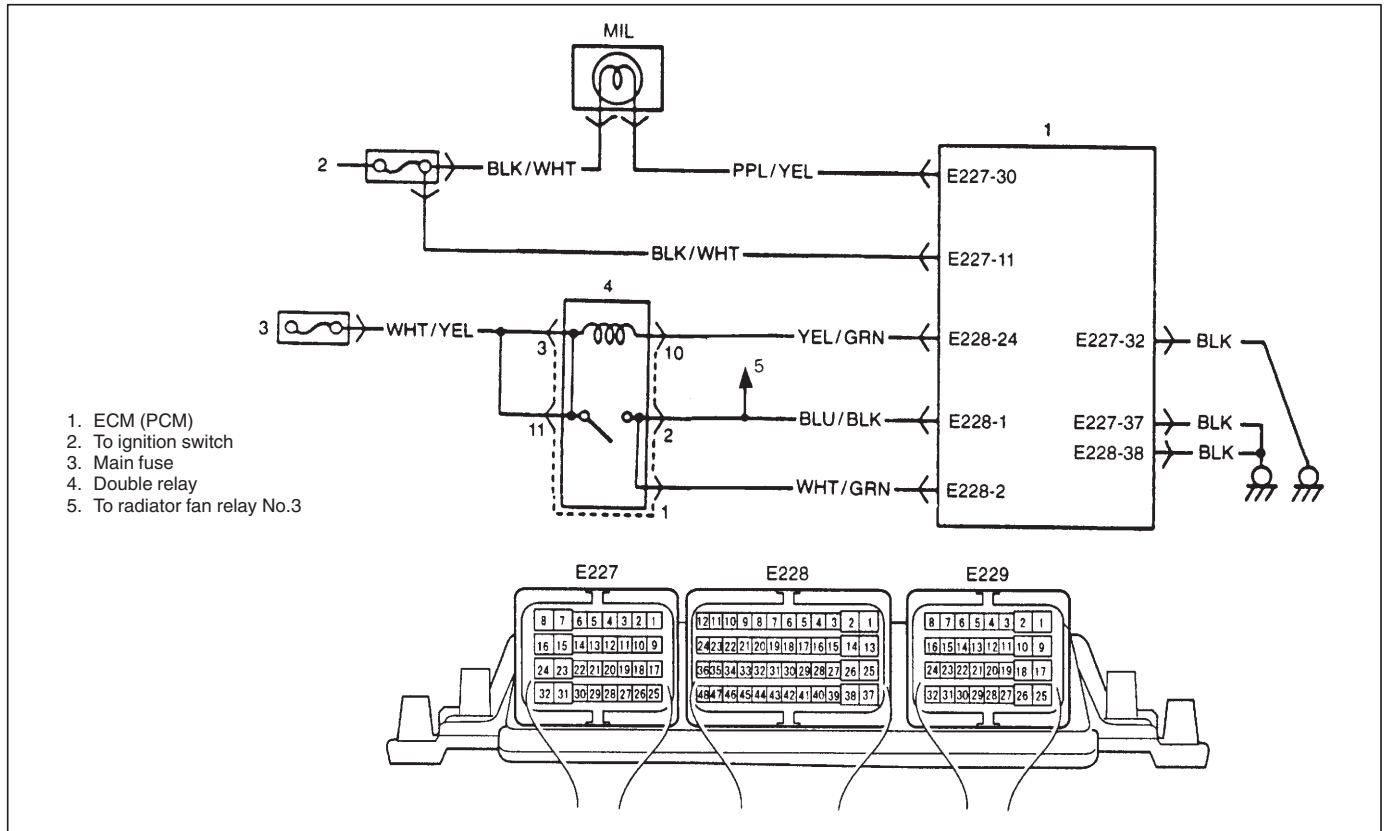

CIRCUIT DESCRIPTION

When the ignition switch is turned ON, ECM causes the main relay to turn ON (close the contact point). Then, ECM being supplied with the main power, turns ON the malfunction indicator lamp (MIL). When the engine starts to run and no malfunction is detected in the system, MIL goes OFF but if a malfunction was or is detected, MIL remains ON even when the engine is running.

INSPECTION

STEP	ACTION	YES	NO
1	MIL Power Supply Check: 1) Turn ignition switch ON. Do other indicator/warning lights in combination meter comes ON?	Go to Step 2.	“IG” fuse blown, main fuse blown, Ignition switch malfunction, “BLK/WHT” circuit between “IG” fuse and combination meter or poor coupler connection at combination meter.
2	ECM Power and Ground Circuit Check: Does engine start?	Go to Step 3.	Go to TABLE A-3 ECM (PCM) POWER AND GROUND CIRCUIT CHECK. If engine is not cranked, go to DIAGNOSIS in Section 6G or 6G1.
3	MIL Circuit Check: 1) Turn ignition switch OFF and disconnect connectors from ECM. 2) Check for proper connection to ECM at terminal E227-30. 3) If OK, then using service wire, ground terminal E227-30 in connector disconnected. Does MIL turn on at ignition switch ON?	Substitute a known-good ECM (PCM) and recheck.	Bulb burned out or “PPL/YEL” wire circuit open.

TABLE A-2 MALFUNCTION INDICATOR LAMP CIRCUIT CHECK – MIL REMAINS “ON” AFTER ENGINE STARTS

WIRING DIAGRAM/CIRCUIT DESCRIPTION

Refer to TABLE A-1.

INSPECTION

STEP	ACTION	YES	NO
1	DTC Check. 1) With ignition switch OFF, install scan tool. 2) Start engine and check DTC. Is there any DTC(s).	Go to Step 2 of “ENGINE DIAG. FLOW TABLE” in this section.	Go to Step 2.
2	MIL circuit Check: (1) With ignition switch OFF, disconnect couplers from ECM (PCM). Does MIL turn ON at ignition switch ON?	“PPL/YEL” wire shorted to ground circuit.	Substitute a known-good ECM (PCM) and recheck.

TABLE A-3 ECM (PCM) POWER AND GROUND CIRCUIT CHECK – MIL DOESN’T LIGHT AT IGNITION SWITCH ON AND ENGINE DOESN’T START THOUGH IT IS CRANKED UP.

WIRING DIAGRAM

Refer to TABLE A-1.

CIRCUIT DESCRIPTION

When the ignition switch is turned ON, the double relay turns ON (the contact point closes) and the main power is supplied to ECM (PCM).

TABLE A-3
INSPECTION

STEP	ACTION	YES	NO
1	Double Relay Operating Sound Check: Is operating sound of double relay heard at ignition switch ON?	Go to Step 5.	Go to Step 2.
2	Fuse Check: Is main "FI" fuse in good condition?	Go to Step 3.	Check for short in circuits connected to this fuse.
3	Double Relay Check: 1) Turn OFF ignition switch and remove double relay. 2) Check for proper connection to double relay at terminal 3 and 10. 3) If OK, check double relay referring to "Double Relay Inspection" in Section 6E3. Is check result satisfactory?	Go to Step 4.	Replace main relay.
4	ECM (PCM) Power Circuit Check: 1) Turn OFF ignition switch, disconnect connectors from ECM (PCM) and install main relay. 2) Check for proper connection to ECM (PCM) at terminals E227-11, E228-24, E228-1 and E228-2. 3) If OK, then measure voltage between terminal E227-11 and ground, E228-24 and ground with ignition switch ON. Is each voltage 10 – 14 V?	Go to Step 5.	"BLK/WHT", "YEL/GRN" or "WHT/YEL" circuit open.
5	ECM Power Circuit Check: 1) Using service wire, ground terminal E228-24 and measure voltage between terminal E228-1 and ground, E228-2 and ground at ignition switch ON. Is it 10 – 14 V?	Check ground circuits "BLK" for open. If OK, then substitute a known-good ECM (PCM) and recheck.	Go to Step 6.
6	Is operating sound of double relay heard in Step 1?	Go to Step 7.	"WHT/YEL" or "BLU/BLK" wire open
7	Double Relay Check: 1) Check double relay according to procedure in Step 3. Is main relay in good condition?	"WHT/YEL" or "BLU/BLK" wire open.	Replace double relay.

DTC P0100 (DTC P0100) MASS AIR FLOW CIRCUIT MALFUNCTION WIRING DIAGRAM

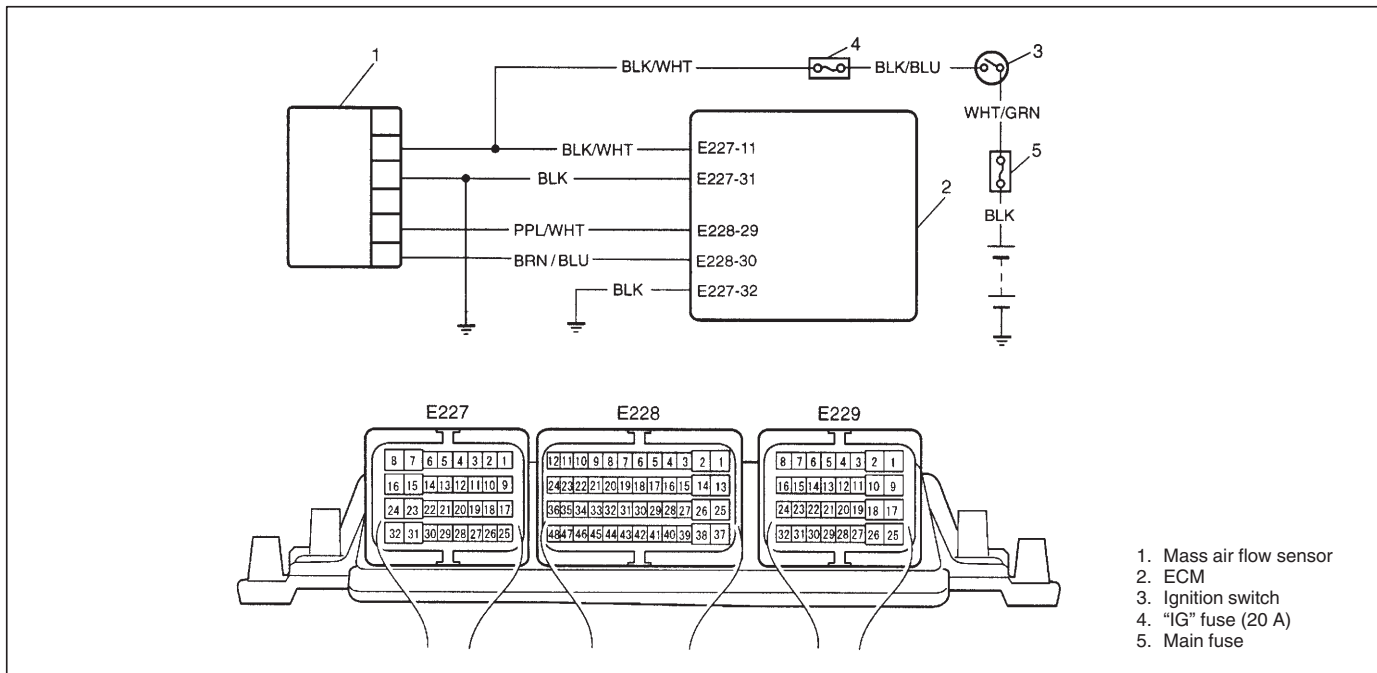

DTC CONFIRMATION PROCEDURE

NOTE:

Check to make sure that the following conditions are satisfied when using this DTC CONFIRMATION PROCEDURE.

- Intake air temp.: -8°C , 18°F or higher
- Engine coolant temp.: $-8 - 110^{\circ}\text{C}$ ($18 - 230^{\circ}\text{F}$)
- Altitude (barometric pressure): 2400 m, 8000 ft or less (560 mmHg, 75 kPa or more)

- 1) Connect scan tool to DLC with ignition switch OFF.
- 2) Turn ON ignition switch and clear DTC, pending DTC and freeze frame data by using scan tool and run engine at idle speed.
- 3) Check DTC and pending DTC by using scan tool.

TROUBLESHOOTING

STEP	ACTION	YES	NO
1	Was "ENGINE DIAG. FLOW TABLE" performed?	Go to Step 2.	Go to "ENGINE DIAG. FLOW TABLE".
2	MAF sensor power supply Check: 1) With ignition switch OFF, disconnect MAF sensor coupler. 2) With ignition switch ON, check voltage between "BLK/WHT" wire terminal of MAF sensor coupler and "BLK" wire terminal of MAF sensor coupler. Is voltage 10 – 14 V?	Go to Step 3.	Faulty "BLK/WHT", "BLK" wire.
3	MAF sensor output voltage Check: 1) With ignition switch OFF, connect MAF sensor coupler. 2) Remove ECM (PCM) cover. 3) Start engine and check voltage between E228-29 and E228-30 terminal at idle speed. Is voltage about 2 V?	Poor E228-29 and E228-30 connection. Faulty "BLK" wire connection. If OK, substitute a known-good ECM and recheck. (See NOTE)	Faulty "PPL/WHT", "BRN/BLU" wire. Poor MAF sensor coupler terminal connection. If wire and connection are OK, substitute a known-good MAF sensor and recheck.

NOTE:

If DTC is checked using generic scan tool only and DTC P0101 (P0100) Diag. Flow Table is not performed yet, go to the table before ECM replacement.

DTC P0101 (P0100) MAF SENSOR CIRCUIT RANGE/PERFORMANCE PROBLEM**WIRING DIAGRAM**

Refer to DTC P0100.

DTC CONFIRMATION PROCEDURE**NOTE:**

Check to make sure that the following conditions are satisfied when using this DTC CONFIRMATION PROCEDURE.

- Intake air temp.: -8°C , 18°F or higher
- Engine coolant temp.: $-8 - 110^{\circ}\text{C}$ ($18 - 230^{\circ}\text{F}$)
- Altitude (barometric pressure): 2400 m, 8000 ft or less (560 mmHg, 75 kPa or more)

- 1) Connect scan tool to DLC with ignition switch OFF.
- 2) Turn ON ignition switch and clear DTC, pending DTC and freeze frame data by using scan tool and run engine at idle speed for 10 sec. or more.
- 3) Then run engine over 3000 rpm for 10 sec. or more.
- 4) Check DTC and pending DTC.

TROUBLESHOOTING

STEP	ACTION	YES	NO
1	Was "ENGINE DIAG. FLOW TABLE" performed?	Go to Step 2.	Go to "ENGINE DIAG. FLOW TABLE".
2	1) Remove ECM (PCM) cover referring to "Voltage Check" in this section. 2) Start engine and check voltage between E228-29 and E228-30 terminals. Engine speed at 3000 rpm: about 3.1 V Engine speed at idling: about 2 V Is each value satisfied?	Intermittent trouble or faulty ECM. Check for intermittent referring to "Intermittent and Poor Connection" in Section 0A. (See NOTE.)	Clogged or leaky air intake system. If all are OK, substitute a known-good MAF sensor and recheck.

NOTE:

If DTC is checked using generic scan tool only and DTC P0100 (P0100) Diag. Flow Table is not performed yet, go to the table before ECM replacement.

DTC P0110 INTAKE AIR TEMP. (IAT) CIRCUIT MALFUNCTION WIRING DIAGRAM

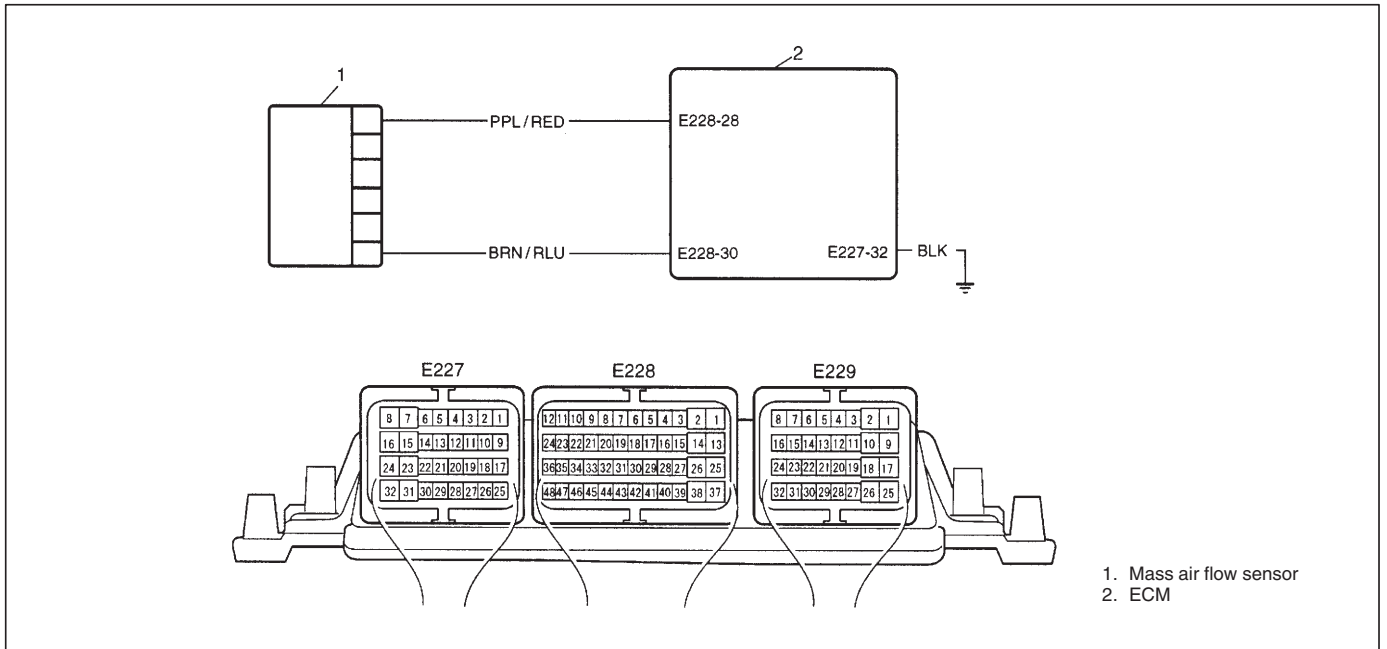

DTC CONFIRMATION PROCEDURE

- 1) Connect scan tool to DLC with ignition switch OFF.
- 2) Turn ON ignition switch and clear DTC, pending DTC and freeze frame data by using scan tool.
- 3) Turn OFF ignition switch, then ON.
- 4) Check DTC and pending DTC by using scan tool.

TROUBLESHOOTING

STEP	ACTION	YES	NO
1	Was "ENGINE DIAG. FLOW TABLE" performed?	Go to Step 2.	Go to "ENGINE DIAG. FLOW TABLE".
2	Check IAT Sensor and Its Circuit. 1) Connect scan tool with ignition switch OFF. 2) Turn ignition switch ON. 3) Check intake air temp. displayed on scan tool. Is -40°C (-40°F) or 131°C (268°F) indicated?	Go to Step 3.	Intermittent trouble. Check for intermittent referring to "Intermittent and Poor Connection" in Section 0A.
3	Check Wire Harness. 1) Disconnect MAF sensor (built-in IAT sensor) connector with ignition switch OFF. 2) Check for proper connection to MAF sensor (built-in IAT sensor) at "PPL/RED" and "BRN/BLU" wire terminals. 3) If OK, then with ignition switch ON, is voltage applied to "PPL/RED" wire terminal of harness side about 5 V?	Go to Step 4.	"PPL/RED" wire open or shorted to power, or poor E228-28 connection. If wire and connection are OK, substitute a known-good ECM and recheck.
4	Does scan tool indicate -40°C (-40°F) at Step 2?	Go to Step 6.	Go to Step 5.
5	Check Wire Harness. 1) Disconnect MAF sensor connector. 2) Check intake air temp. displayed on scan tool. Is -40°C (-40°F) indicated?	Replace MAP sensor.	"PPL/RED" wire shorted to ground. If wire is OK, substitute a known-good ECM and recheck.
6	Check Wire Harness. 1) Using service wire, connect MAF sensor (built-in IAT sensor) connector terminals. (between "PPL/RED" wire terminal and "BRN/BLU" wire terminal of harness side) 2) Turn ignition switch ON and check intake air temp. displayed on scan tool. Is 131°C (268°F) indicated?	Replace MAF sensor (built-in IAT sensor).	"BRN/BLU" wire open or poor E228-30 connection. If wire and connection are OK, substitute a known-good ECM and recheck.

DTC P0115 (DTC P0115) ENGINE COOLANT TEMP. SENSOR CIRCUIT MALFUNCTION WIRING DIAGRAM

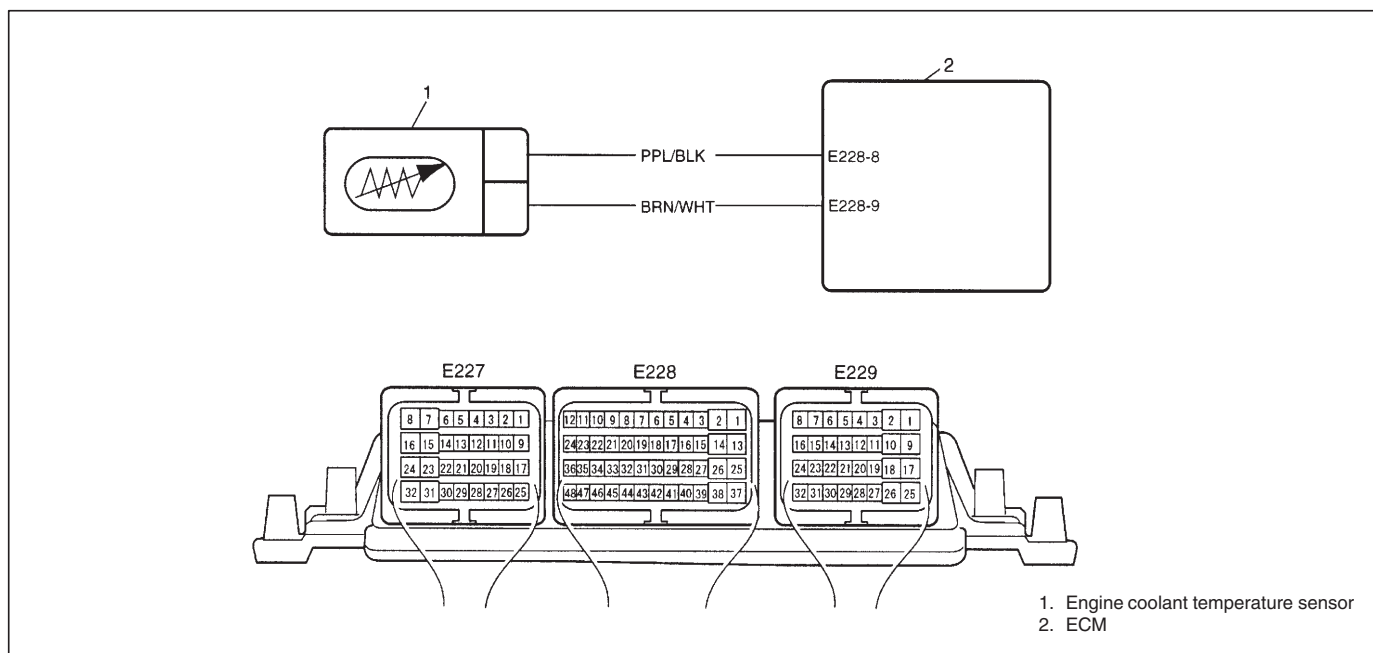

DTC CONFIRMATION PROCEDURE

- 1) Connect scan tool to DLC with ignition switch OFF.
- 2) Turn ON ignition switch and clear DTC, pending DTC and freeze frame data by using scan tool and run engine at idle speed for 10 sec. or more.
- 3) Check DTC and pending DTC by using scan tool.

TROUBLESHOOTING

STEP	ACTION	YES	NO
1	Was "ENGINE DIAG. FLOW TABLE" performed?	Go to Step 2.	Go to "ENGINE DIAG. FLOW TABLE".
2	Check Wire Harness. 1) Remove intercooler referring to "INTERCOOLER" in Section 6E3. 2) Disconnect ECT sensor connector with ignition switch OFF. 3) Check for proper connection to ECT sensor at "PPL/BLK" and "BRN/WHT" wire terminals. 4) If OK, check voltage between "PPL/BLK" and "BRN/WHT" wire terminals of harness side with ignition switch ON. Is voltage about 5 V?	Go to Step 3.	"PPL/BLK" wire open or shorted to power/ground. "BRN/WHT" wire open. Poor E228-8 or E228-9 connection.
3	Check ECT Sensor and Its Circuit 1) Connect ECT sensor to its connector. 2) Connect scan tool to DLC with ignition switch OFF and run engine. Does coolant temp. on scan tool vary?	Substitute a known-good ECM and recheck.	Faulty ECT sensor.

DTC P0121 (DTC P0120) THROTTLE POSITION CIRCUIT RANGE/PERFORMANCE PROBLEM
DTC P0604 (P0120) THROTTLE POSITION SENSOR MONITORING SYSTEM MALFUNCTION

WIRING DIAGRAM

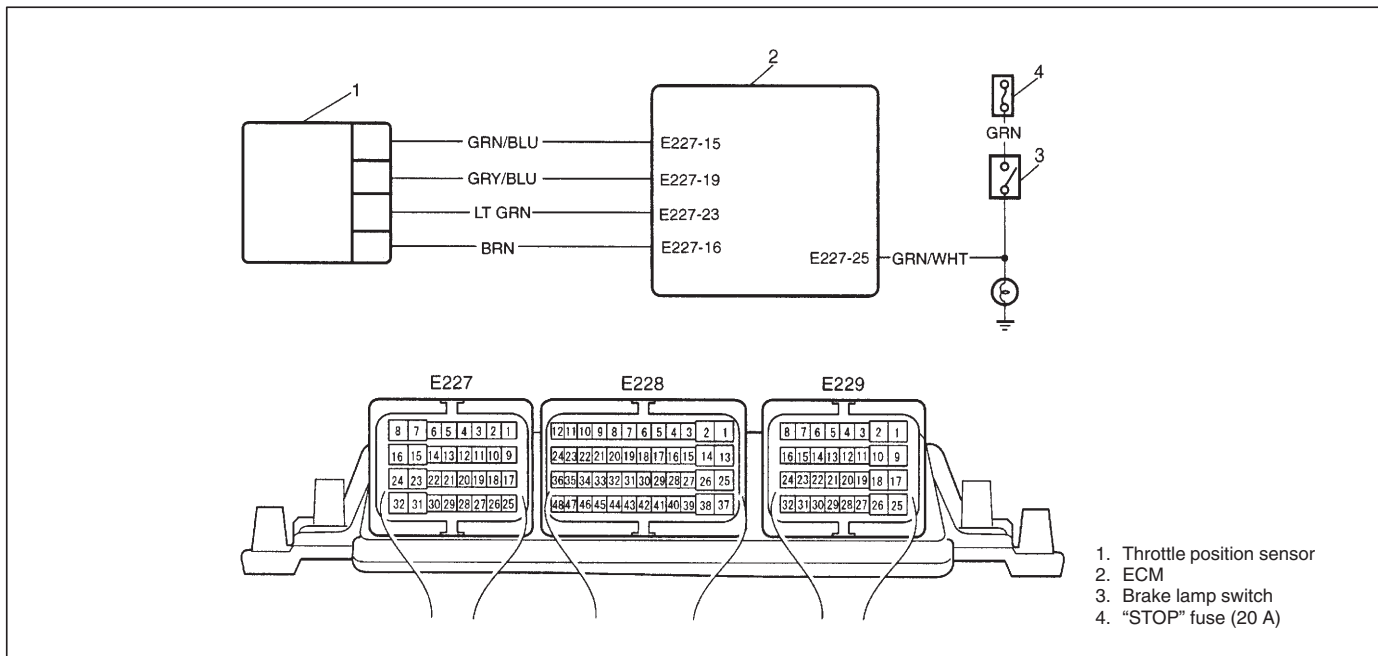

- 1. Throttle position sensor
- 2. ECM
- 3. Brake lamp switch
- 4. "STOP" fuse (20 A)

DTC CONFIRMATION PROCEDURE

- 1) Connect scan tool to DLC with ignition switch OFF.
- 2) Turn ON ignition switch and clear DTC, pending DTC and freeze frame data by using scan tool and run engine at idle speed for 10 sec. or more.
- 3) Check DTC and pending DTC by using scan tool.

TROUBLESHOOTING

STEP	ACTION	YES	NO
1	Was "ENGINE DIAG. FLOW TABLE" performed?	Go to Step 2.	Go to "ENGINE DIAG. FLOW TABLE".
2	Check Sensor Power Supply Circuit Is DTC below also indicated? <Using Suzuki mode of Suzuki Scan tool> P1614 <Using Generic Scan tool or Euro mode of Suzuki Scan tool> P0560	Go to DTC P1614 (P0560) Diag. Flow Table.	Go to Step 3.
3	Check Wire Harness. 1) Disconnect connector from TP sensor with ignition switch OFF. 2) Check for proper connection to TP sensor at each terminals. 3) If OK, then with ignition switch ON, check voltage between "LT GRN" wire and "BRN" wire terminals at connector of TP sensor. Is voltage about 5 V?	Go to Step 4.	"LT GRN" wire open, "BRN" wire open, poor E227-23 connection, or poor E227-16 connection. If wire and connection are OK, substitute a known-good ECM and recheck.
4	Check TP Sensor output voltage. 1) Remove ECM cover referring to "Voltage Check" in this section. 2) With ignition switch ON, check voltage between E227-15 and ground, when accelerator pedal is at idle position to fully depressed position. Is voltage 0.5 – 3.35 V?	Substitute a known-good ECM and recheck.	"GRN/BLU" wire open, "GRN/BLU" wire shorted to ground circuit/power circuit. Poor TP sensor connector. If wire and connection are OK, substitute a known-good TP sensor.

DTC P0180 FUEL TEMP. SENSOR CIRCUIT MALFUNCTION WIRING DIAGRAM

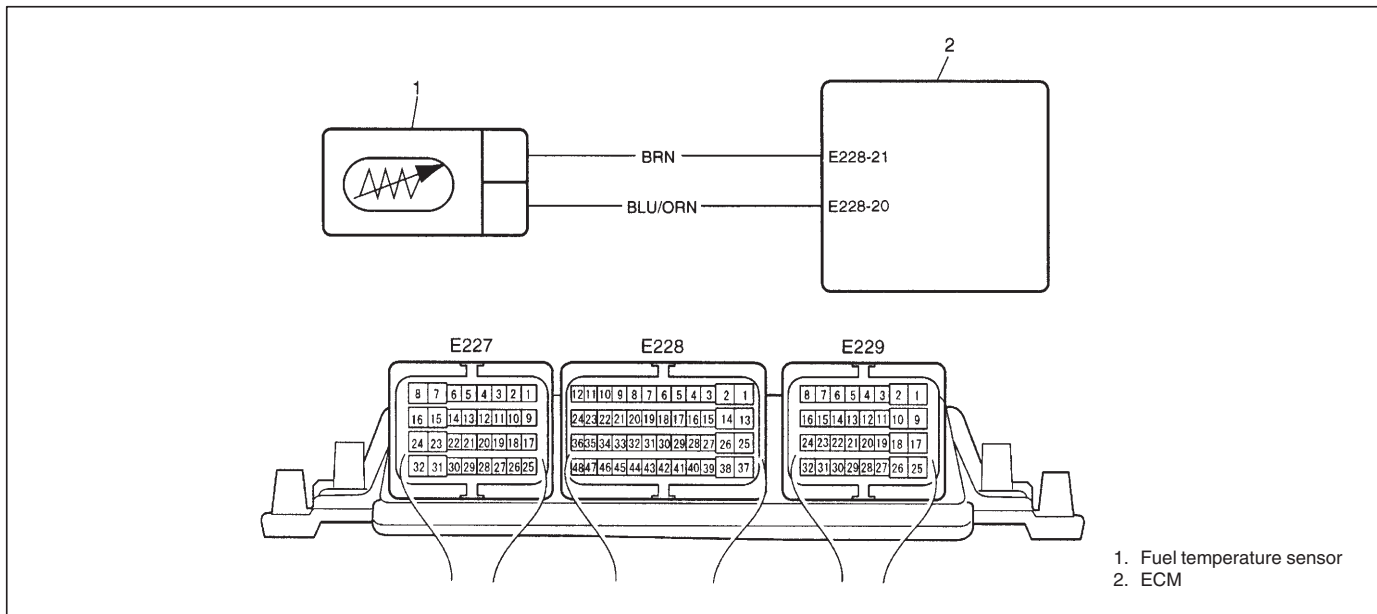

DTC CONFIRMATION PROCEDURE

- 1) Connect scan tool to DLC with ignition switch OFF.
- 2) Turn ON ignition switch and clear DTC, pending DTC and freeze frame data by using scan tool and run engine at idle speed for 10 sec. or more.
- 3) Check DTC and pending DTC by using scan tool.

TROUBLESHOOTING

STEP	ACTION	YES	NO
1	Was "ENGINE DIAG. FLOW TABLE" performed?	Go to Step 2.	Go to "ENGINE DIAG. FLOW TABLE".
2	<ol style="list-style-type: none"> 1) Remove intercooler referring to "INTERCOOLER" in Section 6E3. 2) Disconnect fuel temp. sensor connector with ignition switch OFF. 3) Check for proper connection to fuel temp. sensor at "BLU/ORN" and "BRN" wire terminals. 4) If OK, check voltage between "BLU/ORN" and "BRN" wire terminals with ignition switch ON. Is voltage about 5 V? 	Go to Step 3.	"BLU/ORN" wire open or shorted to power/ground. "BRN" wire open. Poor E228-20 or E228-21 connection. If wire and connection are OK, substitute a known-good ECM and recheck.
3	<ol style="list-style-type: none"> 1) Check fuel temp. sensor for resistance referring to "FUEL TEMPERATURE SENSOR" in Section 6E3. Is resistance as specified? 	Substitute a known-good fuel temp. sensor and recheck.	Replace fuel temp. sensor.

DTC P0190 (P0190) FUEL RAIL PRESSURE SENSOR CIRCUIT MALFUNCTION WIRING DIAGRAM

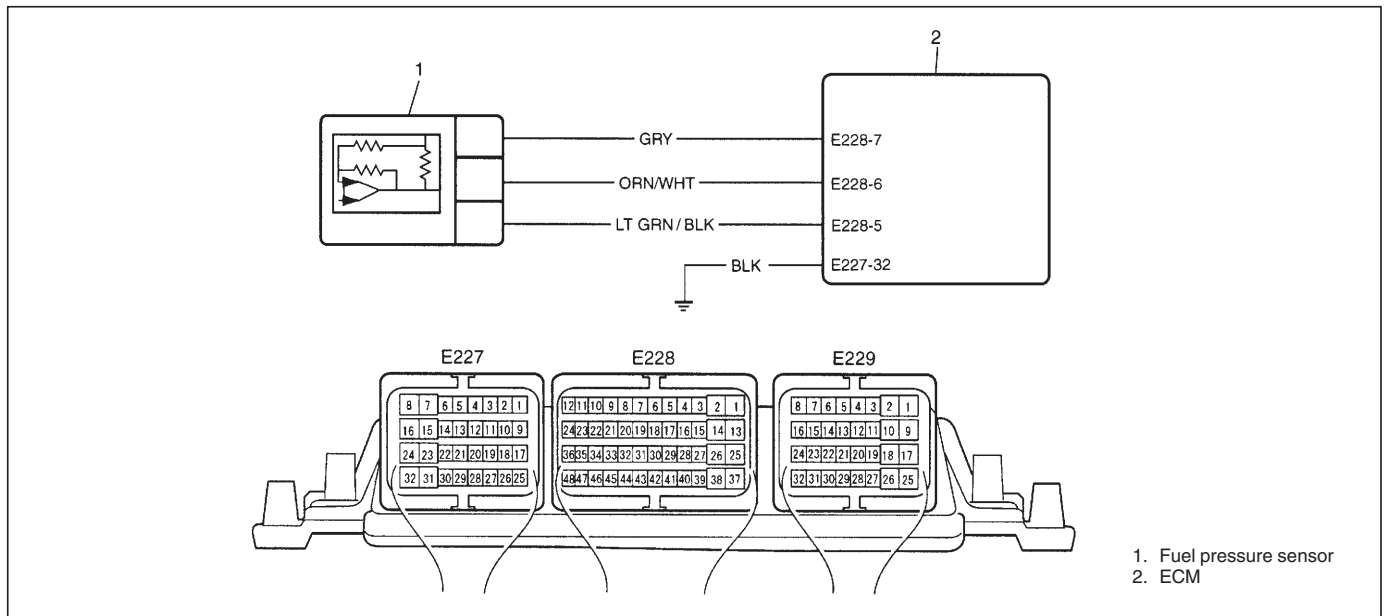

DTC CONFIRMATION PROCEDURE

- 1) Connect scan tool to DLC with ignition switch OFF.
- 2) Turn ON ignition switch and clear DTC, pending DTC and freeze frame data by using scan tool and run engine at idle speed for 10 sec. or more.
- 3) Check DTC and pending DTC by using scan tool.

TROUBLESHOOTING

STEP	ACTION	YES	NO
1	Was "ENGINE DIAG. FLOW TABLE" performed?	Go to Step 2.	Go to "ENGINE DIAG. FLOW TABLE".
2	<p>Check Sensor Power Supply Circuit</p> <p>1) Connect scan tool to DLC with ignition switch OFF and then turn ignition switch ON.</p> <p>2) Does scan tool indicate DTC as shown below?</p> <p><Using Suzuki mode of Suzuki Scan tool> P1614</p> <p><Using Generic Scan tool or Euro mode of Suzuki Scan tool> P0560</p>	Go to DTC P1614 (P0560) Diag. Flow Table.	Go to Step 3.
3	<p>Check Wire Harness</p> <p>1) Disconnect connector from fuel pressure sensor with ignition switch OFF.</p> <p>2) Check for proper connection to fuel pressure sensor at each terminals.</p> <p>3) If OK, then with ignition switch ON, check voltage between "LT GRN/BLK" wire and "GRY" wire terminals at connector of fuel pressure sensor.</p> <p>Is voltage about 5 V?</p>	Go to Step 4.	<p>"LT GRN/BLK" wire open, "LT GRN/BLK" wire shorted to ground circuit/power circuit, "GRY" wire open, poor E228-5 connection, or poor E228-7 connection.</p> <p>If wire and connection are OK, substitute a known-good ECM and recheck.</p>
4	<p>Check Fuel Pressure Sensor Output Voltage</p> <p>1) Remove ECM cover referring to "Voltage Check" in this section.</p> <p>2) Connect fuel pressure sensor connector.</p> <p>3) Start engine and check voltage between E228-6 and E227-32 terminal at idle speed.</p> <p>Is voltage about 1.3 V?</p>	Substitute a known-good ECM and recheck.	<p>"ORN/WHT" wire open, "ORN/WHT" wire shorted to ground circuit/power circuit.</p> <p>If wire and connection are OK, substitute a known-good fuel pressure sensor and recheck.</p>

**DTC P0191 (P0230) FUEL RAIL PRESSURE SENSOR/PRESSURE REGULATOR
CONSISTENCY FUNCTION**
DTC P1112 (P0230) FUEL PRESSURE MONITORING CIRCUIT MALFUNCTION
WIRING DIAGRAM

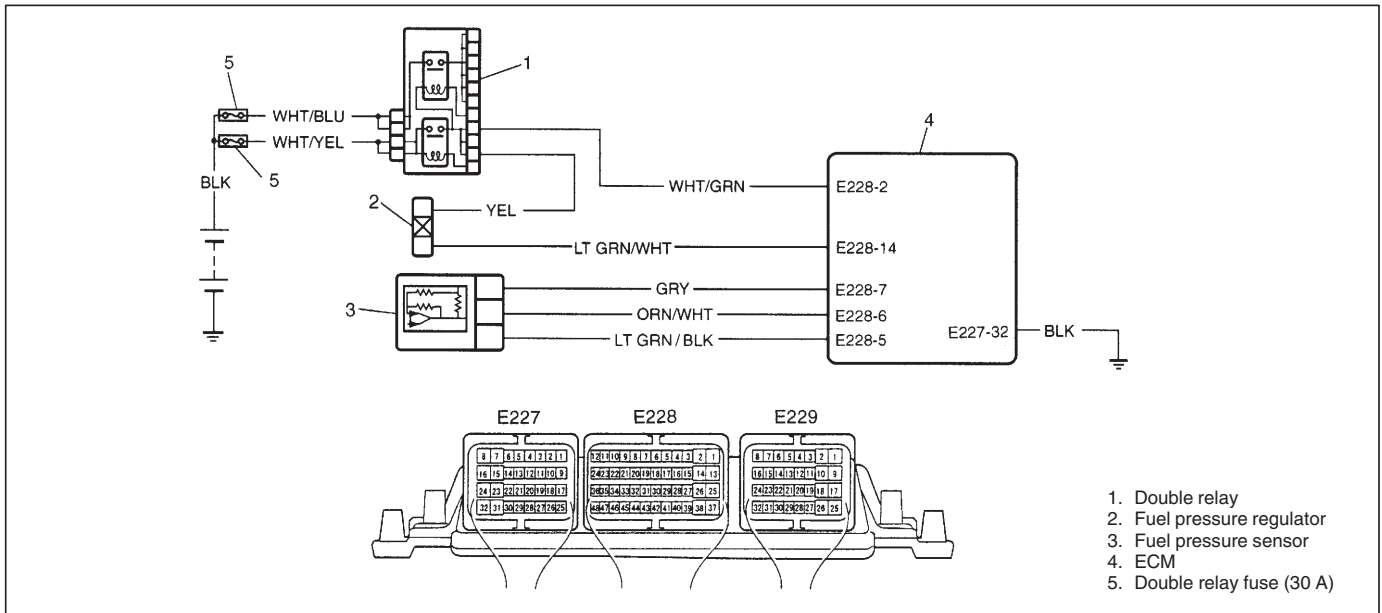

DTC CONFIRMATION PROCEDURE

- 1) Connect scan tool to DLC with ignition switch OFF.
- 2) Turn ON ignition switch and clear DTC, pending DTC and freeze frame data by using scan tool and run engine at idle speed for 10 sec. or more.
- 3) Then run engine 1000 rpm or more for 10 sec.
- 4) Check DTC and pending DTC by using scan tool.

TROUBLESHOOTING

STEP	ACTION	YES	NO
1	Was "ENGINE DIAG. FLOW TABLE" performed?	Go to Step 2.	Go to "ENGINE DIAG. FLOW TABLE".
2	Check Fuel Shortage 1) Is there enough fuel in fuel tank?	Go to Step 3.	Supply fuel into fuel tank.
3	Check Wire Harness 1) With ignition switch OFF, disconnect ECM connector. 2) Check for proper connection to ECM at E228-2 and E228-14 terminals. 3) If OK, check resistance between E228-2 and E228-14 terminals. Is resistance 2 – 3 Ω?	Go to Step 4.	Faulty "WHT/GRN" wire, "YEL" wire or "LT GRN/WHT" wire. If wire is OK, substitute a known-good double relay or injection pump and recheck.
4	Check Fuel Pressure Sensor Output Voltage 1) Remove ECM cover referring to "Voltage Check" in the Section. 2) Connect fuel pressure sensor connector. 3) Start engine and check voltage between E228-6 and E227-32 terminal at idle speed. Is voltage about 1.3 V?	Go to Step 5.	"ORN/WHT" wire open, "ORN/WHT" wire shorted to ground circuit/power circuit. Poor fuel pressure sensor connector terminal connection. If wire and connection are OK, substitute a known-good fuel pressure sensor and recheck.
5	Check Fuel Leakage 1) Perform step 1), 2) and 3) of "DTC CONFIRMATION PROCEDURE". 2) Check fuel leakage on Fuel System. Is it in good condition?	<ul style="list-style-type: none"> ● Fuel line clogged. ● Faulty fuel pressure regulator. If OK, substitute a known-good ECM and recheck. (See NOTE.)	Repair or replace.

NOTE:

If DTC is checked using generic scan tool only and DTC P1138 (P0230) Diag. Flow Table is not performed yet, go to the table before ECM replacement.

- DTC P0201 (P0200) INJECTOR CIRCUIT MALFUNCTION CYLINDER 1
- DTC P0202 (P0200) INJECTOR CIRCUIT MALFUNCTION CYLINDER 2
- DTC P0203 (P0200) INJECTOR CIRCUIT MALFUNCTION CYLINDER 3
- DTC P0204 (P0200) INJECTOR CIRCUIT MALFUNCTION CYLINDER 4

WIRING DIAGRAM

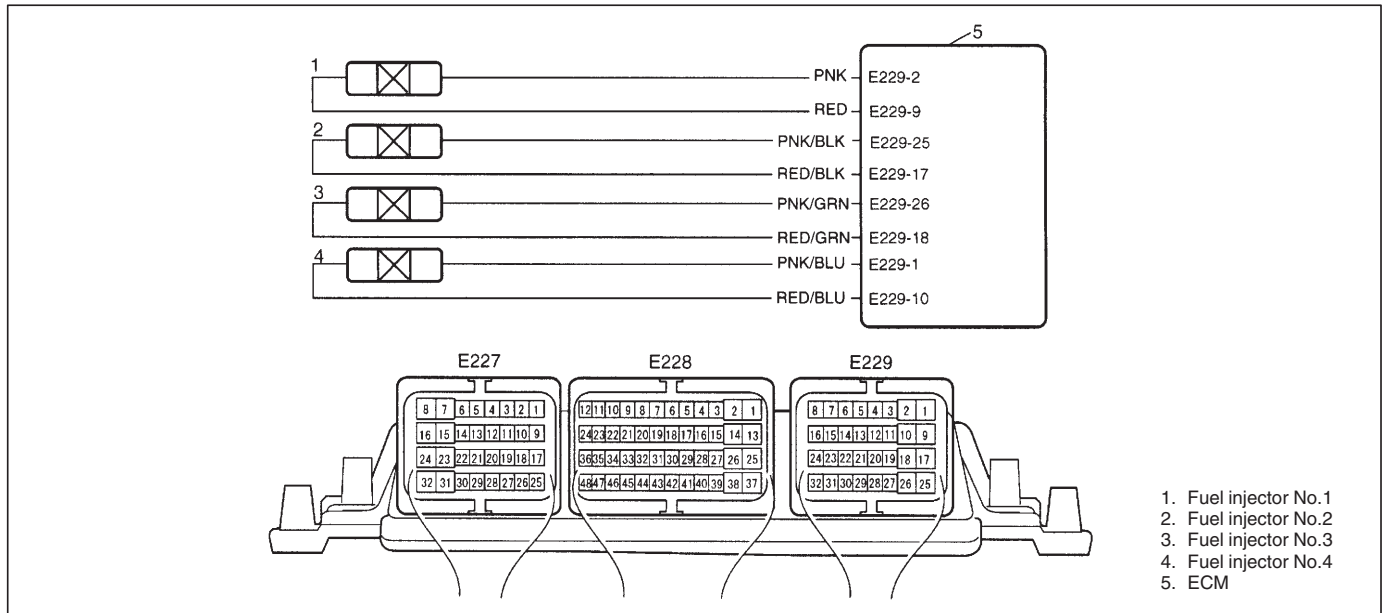

DTC CONFIRMATION PROCEDURE

- 1) Connect scan tool to DLC with ignition switch OFF.
- 2) Turn ON ignition switch and clear DTC, pending DTC and freeze frame data by using scan tool and run engine at idle speed for 10 sec. or more.
- 3) Check DTC and pending DTC by using scan tool.

TROUBLESHOOTING

STEP	ACTION	YES	NO
1	Was "ENGINE DIAG. FLOW TABLE" performed?	Go to Step 2.	Go to "ENGINE DIAG. FLOW TABLE".
2	<p>Check Fuel Injector Circuit For Short</p> <p>1) With ignition switch OFF, disconnect ECM connector.</p> <p>2) Check for proper connection to ECM at E229-2, E229-9, E229-25, E229-17, E229-26, E229-18, E229-1 and E229-10 terminals.</p> <p>3) If OK, disconnect connector at all fuel injectors.</p> <p>4) Check for resistance between injector connector terminals.</p> <p>Is resistance between terminals of all fuel injectors infinity (∞)?</p>	Go to Step 3.	Short circuit between "PNK" wire and "RED" wire, "PNK/BLK" wire and "RED/BLK" wire, "PNK/GRN" wire and "RED/GRN" wire, or "PNK/BLU" wire and "RED/BLU" wire.
3	<p>Check Fuel Injector Circuit For Open</p> <p>1) Connect connector to all fuel injectors.</p> <p>2) Check for resistance between following terminals of ECM connector.</p> <p>E229-2 and E229-9: 0.56 Ω (maximum)</p> <p>E229-25 and E229-17: 0.56 Ω (maximum)</p> <p>E229-26 and E229-18: 0.56 Ω (maximum)</p> <p>E229-1 and E229-10: 0.56 Ω (maximum)</p> <p>Is check result as specified?</p>	Substitute a known-good ECM and recheck.	Open "PNK" wire, "RED" wire, "PNK/BLK" wire, "RED/BLK" wire, "PNK/GRN" wire, "RED/GRN" wire, "PNK/BLU" wire or "RED/BLU" wire. If wire is OK, substitute a known-good fuel injector and recheck.

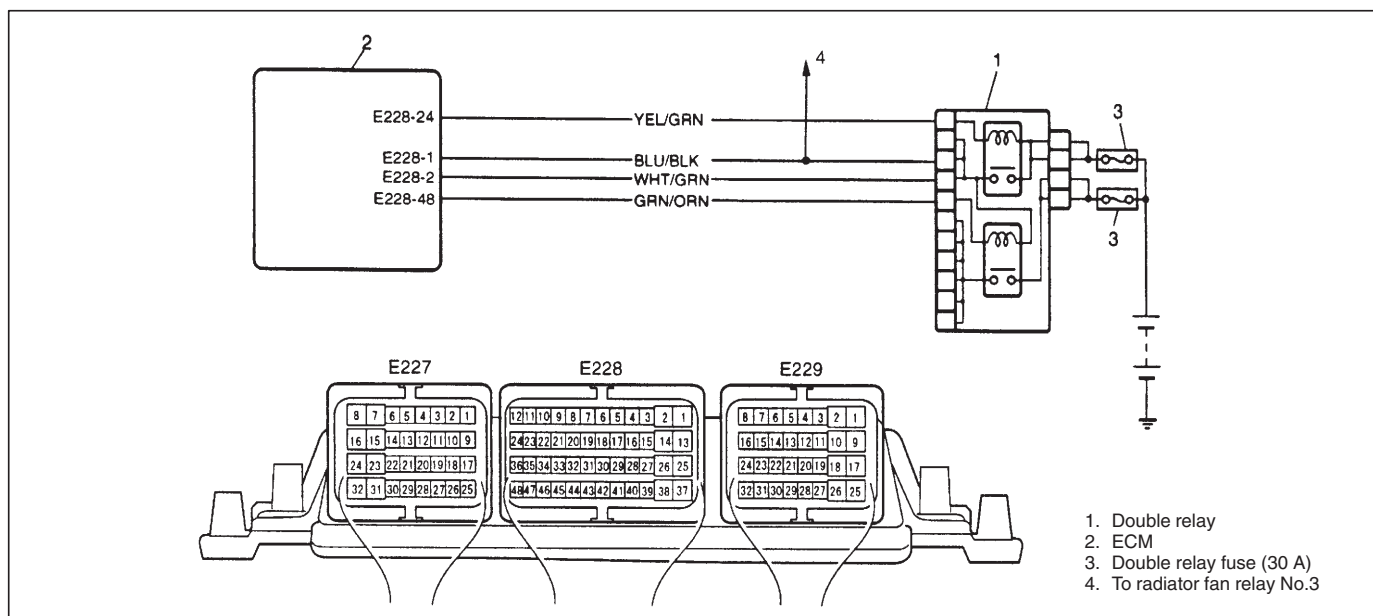
DTC P0215 DOUBLE RELAY CIRCUIT MALFUNCTION**WIRING DIAGRAM****DTC CONFIRMATION PROCEDURE**

- 1) Connect scan tool to DLC with ignition switch OFF.
- 2) Turn ON ignition switch and clear DTC, pending DTC and freeze frame data by using scan tool.
- 3) Turn ON ignition switch after OFF for 5 sec.
- 4) Check DTC and pending DTC by using scan tool.

TROUBLESHOOTING

STEP	ACTION	YES	NO
1	Was "ENGINE DIAG. FLOW TABLE" performed?	Go to Step 2.	Go to "ENGINE DIAG. FLOW TABLE".
2	Check Double Relay Function 1) Turn ignition switch ON for 5 sec. and then OFF. Is click of double relay heard from double relay at 2 sec. after ignition switch OFF?	Substitute a known-good ECM and recheck.	Go to Step 3.
3	1) Remove ECM cover referring to "Voltage Check" in this section. 2) Check voltage between E228-1/2 and ground. Ignition switch ON: 10 – 14 V Ignition switch OFF: about 0 V Is check result as specified?	Poor E228-1/2 connection. If connection is OK, substitute a known-good ECM and recheck.	Go to Step 4.
4	Check Double Relay 1) Check double relay referring to Section 6E3. Is it in good condition?	Go to Step 5.	Faulty double relay.
5	1) Check voltage between E228-24 and ground. Ignition switch ON: about 0 V Ignition switch OFF: 10 – 14 V Is check result as specified?	<ul style="list-style-type: none"> ● Poor C51-86 connection, ● "BLU/BLK" wire open/short or ● "WHT/GRN" wire open/short 	"YEL/GRN" wire open or short.

DTC P0230 FUEL PUMP SUPPLY CIRCUIT MALFUNCTION WIRING DIAGRAM

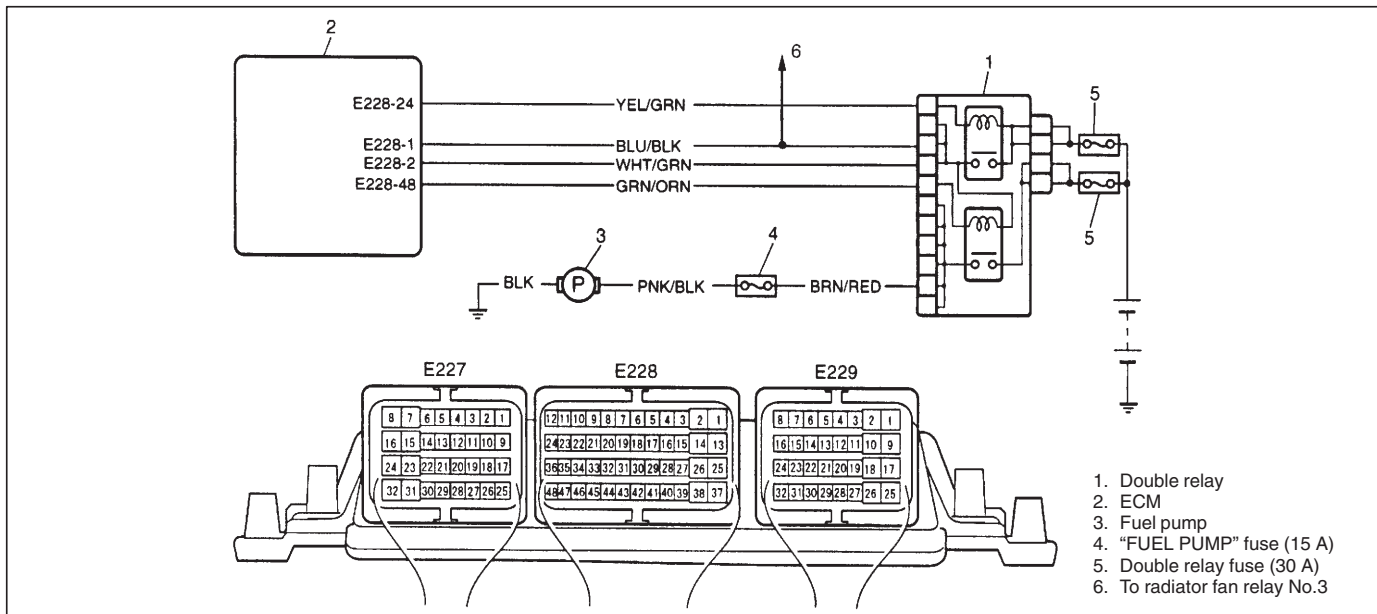

DTC CONFIRMATION PROCEDURE

- 1) Connect scan tool to DLC with ignition switch OFF.
- 2) Turn ON ignition switch and clear DTC, pending DTC and freeze frame data by using scan tool and run engine at idle speed for 10 sec. or more.
- 3) Turn ON ignition switch after OFF for 5 sec.
- 4) Check DTC and pending DTC by using scan tool.

TROUBLESHOOTING

STEP	ACTION	YES	NO
1	Was "ENGINE DIAG. FLOW TABLE" performed?	Go to Step 2.	Go to "ENGINE DIAG. FLOW TABLE".
2	Is operating sound heard from fuel pump?	Substitute a known-good ECM and recheck.	Go to Step 3.
3	Check Double Relay 1) Check double relay referring to Section 6E3. Is it in good condition?	Go to Step 4.	Faulty double relay.
4	Check Fuel Pump Output Circuit 1) Remove ECM cover referring to "Voltage Check" in this section. 2) Check voltage between E228-48 and ground. • Within 5 sec. after ignition switch ON: about 0 V • Over 5 sec. after Ignition switch OFF: 10 – 14 V Is check result as specified?	<ul style="list-style-type: none"> • Poor E228-48 connection • "BLK", "PNK/BLK" or "BRN/RED" wire open/short • Fuse broken or • Faulty fuel pump If all are OK, substitute a known-good ECM and recheck.	"GRN/ORN" wire open/short.

DTC P0243 (P0243) TURBO PRESSURE SOLENOID VALVE CIRCUIT RANGE/ PERFORMANCE PROBLEM

WIRING DIAGRAM

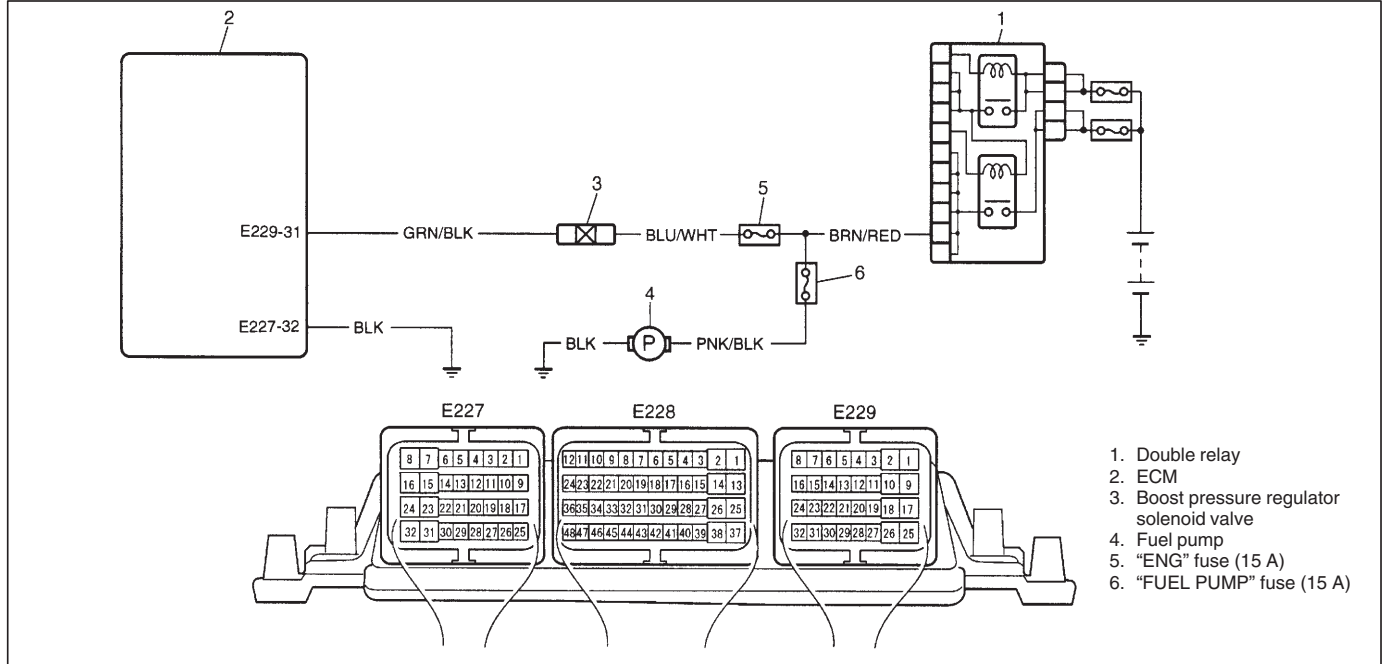

DTC CONFIRMATION PROCEDURE

- 1) Connect scan tool to DLC with ignition switch OFF.
- 2) Turn ON ignition switch and clear DTC, pending DTC and freeze frame data by using scan tool.
- 3) Check DTC and pending DTC by using scan tool.

TROUBLESHOOTING

STEP	ACTION	YES	NO
1	Was "ENGINE DIAG. FLOW TABLE" performed?	Go to Step 2.	Go to "ENGINE DIAG. FLOW TABLE".
2	Is operating sound heard from fuel pump?	Go to Step 3.	Proceed to DTC P0230 Diag. Flow table.
3	<p>Check Wire Harness</p> <p>1) Disconnect boost pressure regulator solenoid valve connector with ignition switch OFF.</p> <p>2) With ignition switch ON, check voltage between "BLU/WHT" wire terminal of solenoid valve connector disconnected and ground.</p> <p>Within 5 sec. after ignition switch ON: about 12 V</p> <p>Over 5 sec. after ignition switch ON: 0 V</p> <p>Is check result as specified?</p>	Go to Step 4.	"BLU/WHT" wire open, shorted to power/ground or fuse broken.
4	<p>Check Boost Pressure Regulator Solenoid Valve</p> <p>1) Check solenoid valve referring to Section 6E3.</p> <p>Is check result as specified?</p>	"GRN/BLK" wire open or shorted to power/ground. Poor E229-31 connection. If wire and connection are OK, substitute a known-good ECM and recheck. (See NOTE.)	Faulty solenoid valve.

NOTE:

If DTC is checked using generic scan tool only and DTC P0245 (P0243)/P0246 (P0243) Diag. Flow Table is not performed yet, go to the table before ECM replacement.

DTC P0245 (P0243)/P0246 (P0243) TURBO PRESSURE SOLENOID VALVE CIRCUIT RANGE/PERFORMANCE PROBLEM

WIRING DIAGRAM

Refer to DTC P0243 (P0243).

TROUBLESHOOTING

STEP	ACTION	YES	NO
1	Was "ENGINE DIAG. FLOW TABLE" performed?	Go to Step 2.	Go to "ENGINE DIAG. FLOW TABLE".
2	Check Vacuum Circuit Check vacuum circuit for leak and clogging. Is it in good condition?	Go to Step 3.	Repair or replace.
3	Check boost pressure regulator solenoid valve for resistance referring to "BOOST PRESSURE REGULATOR SOLENOID VALVE" in Section 6E3. Is resistance as specified?	Substitute a known-good ECM and recheck. (See NOTE.)	Replace boost pressure regulator solenoid valve.

NOTE:

If DTC is checked using generic scan tool only and DTC P0243 (P0243) Diag. Flow Table is not performed yet, go to the table before ECM replacement.

DTC CONFIRMATION PROCEDURE

- 1) Connect scan tool to DLC with ignition switch OFF.
- 2) Turn ON ignition switch and clear DTC, pending DTC and freeze frame data by using scan tool.
- 3) Run engine over 2500 rpm for 10 sec.
- 4) Check DTC and pending DTC by using scan tool.

DTC P0380 (P0380)/P1404 (P0380) PRE/POST HEAT RELAY CIRCUIT MALFUNCTION WIRING DIAGRAM

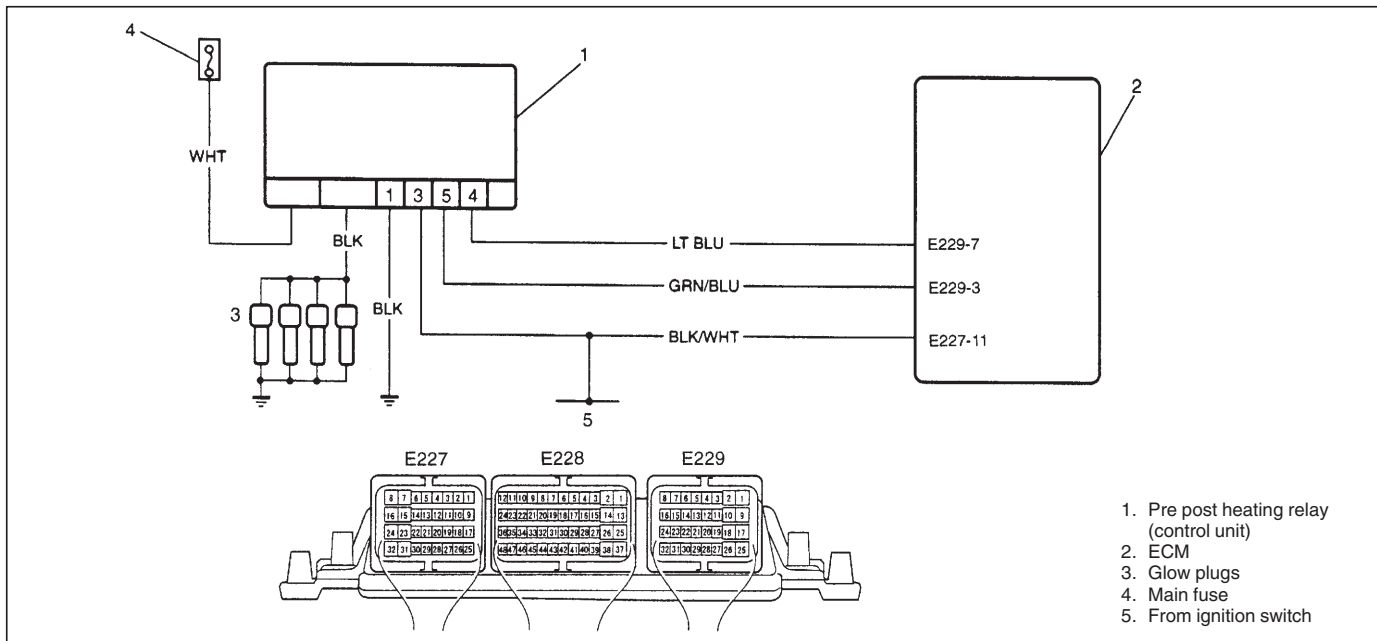

DTC CONFIRMATION PROCEDURE

- 1) Connect scan tool to DLC with ignition switch OFF.
- 2) Turn ON ignition switch and clear DTC, pending DTC and freeze frame data by using scan tool.
- 3) Turn ignition switch ON for 30 sec. after OFF. Then run engine at idle speed for 30 sec.
- 4) Check DTC and pending DTC by using scan tool.

TROUBLESHOOTING

STEP	ACTION	YES	NO
1	Was "ENGINE DIAG. FLOW TABLE" performed?	Go to Step 2.	Go to "ENGINE DIAG. FLOW TABLE".
2	Check Wire Harness 1) Remove ECM cover from ECM referring to "CHECK VOLTAGE" in this section. 2) Check voltage between E229-7/E227-11 and ground with ignition switch ON. Are they about 12 V?	Go to Step 3.	<ul style="list-style-type: none"> ● "LT BLU" wire open or short to ground, or ● "BLK/WHT" wire open or short to ground
3	Check Wire Harness 1) Check voltage between E229-3 and ground with ignition switch ON. Is it about 0 V?	<ul style="list-style-type: none"> ● Poor E229-7 or E229-3 connection If connections are in good condition, substitute a known-good ECM and recheck.	<ul style="list-style-type: none"> ● "GRN/BLU" wire open or short, ● "BLK" wire (between pre-post heating relay and ground) open or short to ground ● "BLK" wire (between pre-post heating relay and glow plug) open or short to ground ● Poor glow plug "BLK" wire terminal connection If all are OK, substitute a known-good ECM and recheck.

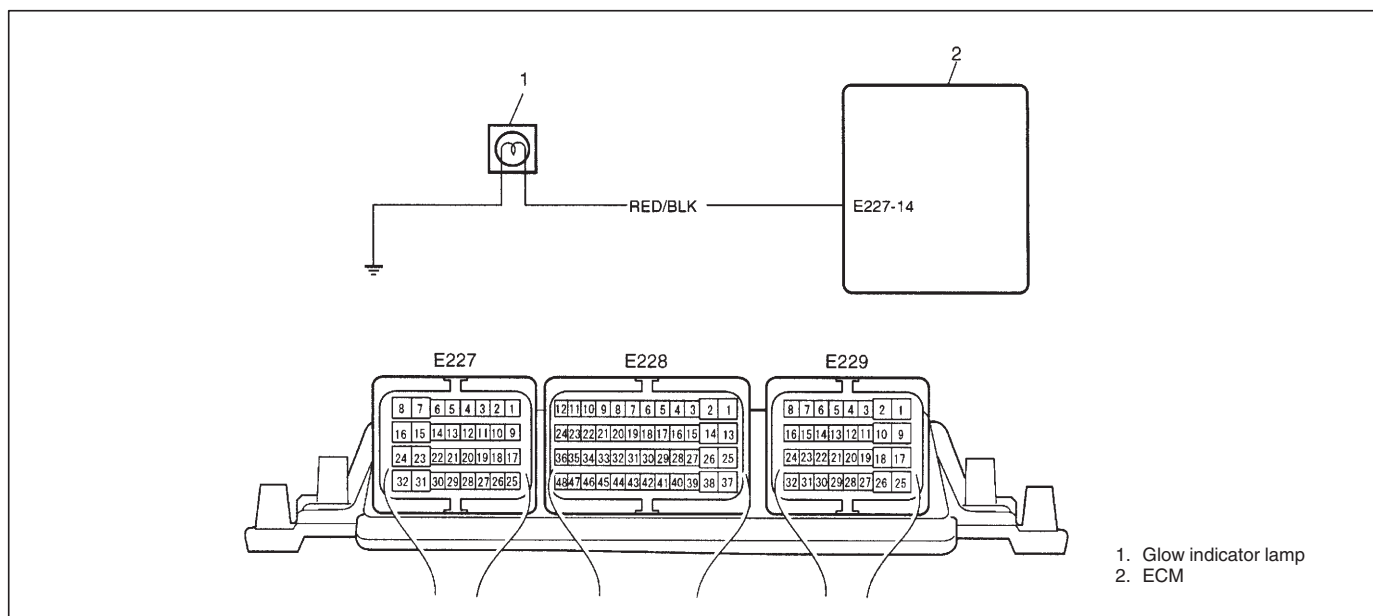
DTC P0381 GLOW INDICATOR LAMP CIRCUIT MALFUNCTION**WIRING DIAGRAM****DTC CONFIRMATION PROCEDURE**

- 1) Connect scan tool to DLC with ignition switch OFF.
- 2) Turn ON ignition switch and clear DTC, pending DTC and freeze frame data by using scan tool.
- 3) Turn ignition switch ON for 30 sec. after OFF.
- 4) Check DTC and pending DTC by using scan tool.

TROUBLESHOOTING

STEP	ACTION	YES	NO
1	Was "ENGINE DIAG. FLOW TABLE" performed?	Go to Step 2.	Go to "ENGINE DIAG. FLOW TABLE".
2	Check Wire Harness <Not Using Suzuki Scan Tool> 1) Disconnect connector at ECM with ignition switch OFF. 2) Supply battery power (12 V) to E227-14 using service wire. Dose glow indicator lamp turn on? <Using Suzuki Scan Tool> 1) Connect Suzuki scan tool to DLC. 2) Execute "Glow Indicator Lamp" in Misc Test. Dose glow indicator lamp flash?	Substitute a known-good ECM and recheck.	<ul style="list-style-type: none"> ● Lamp bulb broken, ● "RED/BLK" wire open or short or ● Poor E227-14 connection

REFERENCE:

As soon as ignition is switched on, ECM turns on glow indicator lamp for a period which depends on engine coolant temp. as shown below.

Engine coolant temp. (°C)	Time turning on glow indicator lamp (sec.)
-30	20
-10	5
0	0.5
18	0

DTC P0401 (P0903) EGR SOLENOID VALVE FLOW INSUFFICIENT DETECTED
DTC P0402 (P0903) EGR SOLENOID VALVE FLOW EXCESSIVE DETECTED

DTC CONFIRMATION PROCEDURE

- 1) Connect scan tool to DLC with ignition switch OFF.
- 2) Turn ON ignition switch and clear DTC, pending DTC and freeze frame data by using scan tool.
- 3) Run engine between 700 and 2700 rpm for 10 or more.
- 4) Check DTC and pending DTC by using scan tool.

TROUBLESHOOTING

STEP	ACTION	YES	NO
1	Was "ENGINE DIAG. FLOW TABLE" performed?	Go to Step 2.	Go to "ENGINE DIAG. FLOW TABLE".
2	Check EGR vacuum circuit and intake air circuit for leak. Is it in good condition?	Go to Step 3.	Repair or replace.
3	Check EGR valve referring to "EGR VALVE" in Section 6E3. Is it in good condition?	Go to Step 4.	Faulty EGR valve.
4	Check EGR solenoid valve for resistance referring to "EGR SOLENOID VALVE" in Section 6E3. Is resistance as specified?	Substitute a known-good ECM and recheck.	Replace EGR solenoid valve.

DTC P0403 (P0403) EGR SOLENOID VALVE CIRCUIT MALFUNCTION

WIRING DIAGRAM

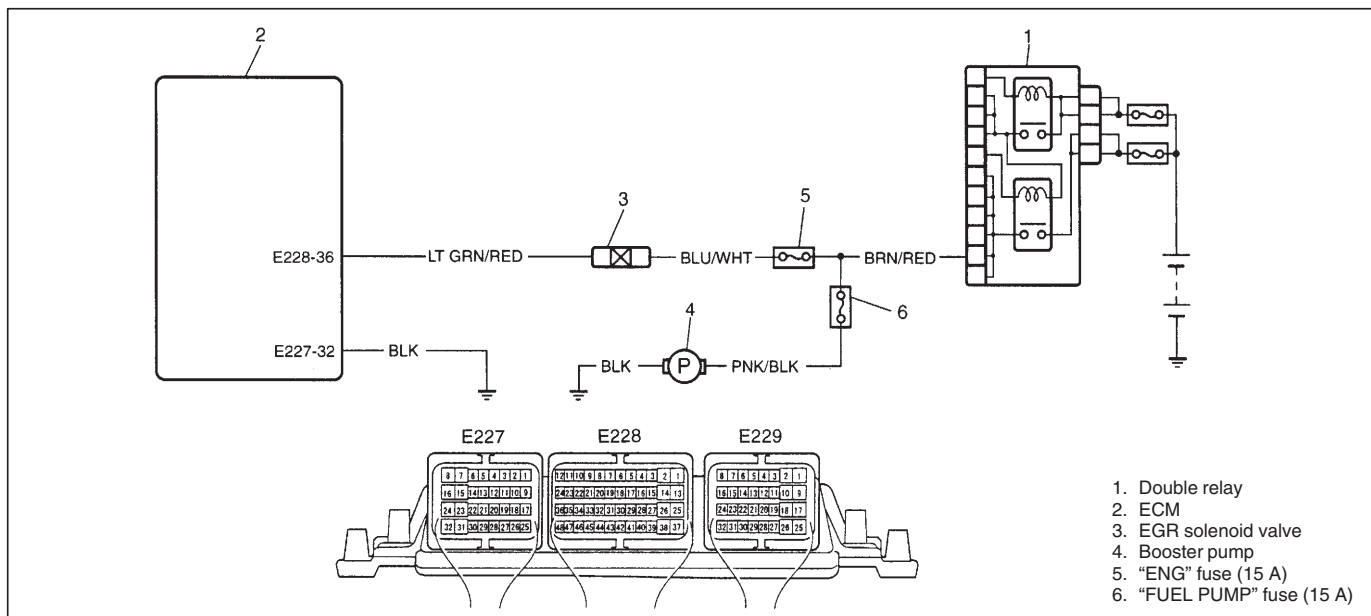

DTC CONFIRMATION PROCEDURE

- 1) Connect scan tool to DLC with ignition switch OFF.
- 2) Turn ON ignition switch and clear DTC, pending DTC and freeze frame data by using scan tool.
- 3) Check DTC and pending DTC by using scan tool.

TROUBLESHOOTING

STEP	ACTION	YES	NO
1	Was "ENGINE DIAG. FLOW TABLE" performed?	Go to Step 2.	Go to "ENGINE DIAG. FLOW TABLE".
2	Is operating sound heard from fuel pump?	Go to Step 3.	Proceed to DTC P0230 Diag. Flow table.
3	Check Wire Harness 1) Disconnect EGR solenoid valve connector with ignition switch turned OFF. 2) With ignition switch ON, check voltage between "BLU/WHT" wire terminal of solenoid valve connector and ground. ● Within 5 sec. after ignition switch ON: 10 – 14 V ● Over 5 sec. after ignition switch ON: about 0 V Is check result as specified?	Go to Step 4.	"BLU/WHT" wire open, shorted to power/ground or fuse broken.
4	Check EGR Solenoid Valve 1) Check solenoid valve referring to Section 6E3. Is it in good condition?	● "LT GRN/RED" wire open or shorted to power/ground ● Poor E228-36 connection If wire and connection are OK, substitute a known-good ECM and recheck.	Faulty EGR solenoid valve.

DTC P0561 (P0560) STABILIZATION OF SENSOR SUPPLY
DTC P0603/P0606/P1171/P1617 ECM FUNCTION
DTC P1169 (P0170) CONDENSER VOLTAGE FUNCTION 1
DTC P1170 (P0170) CONDENSER VOLTAGE FUNCTION 2
DTC P1101 (P0105) BAROMETRIC PRESSURE SENSOR CIRCUIT MALFUNCTION

WIRING DIAGRAM

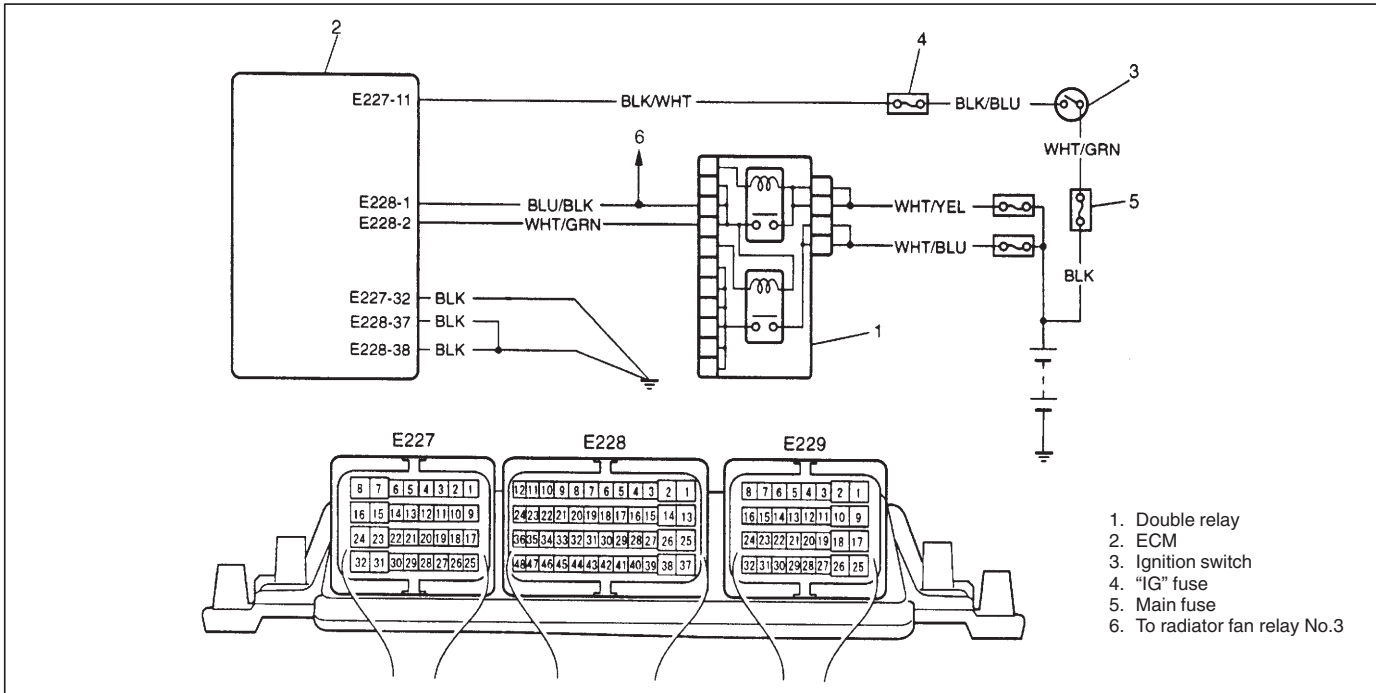

DTC CONFIRMATION PROCEDURE

- 1) Connect scan tool to DLC with ignition switch OFF.
- 2) Turn ON ignition switch and clear DTC, pending DTC and freeze frame data by using scan tool.
- 3) Run engine at idle speed for 10 sec.
- 4) Check DTC and pending DTC by using scan tool.

TROUBLESHOOTING

STEP	ACTION	YES	NO
1	Was "ENGINE DIAG. FLOW TABLE" performed?	Substitute a known-good ECM and recheck. (See NOTE.)	Go to "ENGINE DIAG. FLOW TABLE".

NOTE:

If DTC is checked using generic scan tool only and DTC P1614 (P0560) and DTC P0560 (P0560) Diag. Flow Tables are not performed yet, go to the table before ECM replacement.

DTC P1108 RADIATOR FAN HIGH SPEED CIRCUIT MALFUNCTION WIRING DIAGRAM

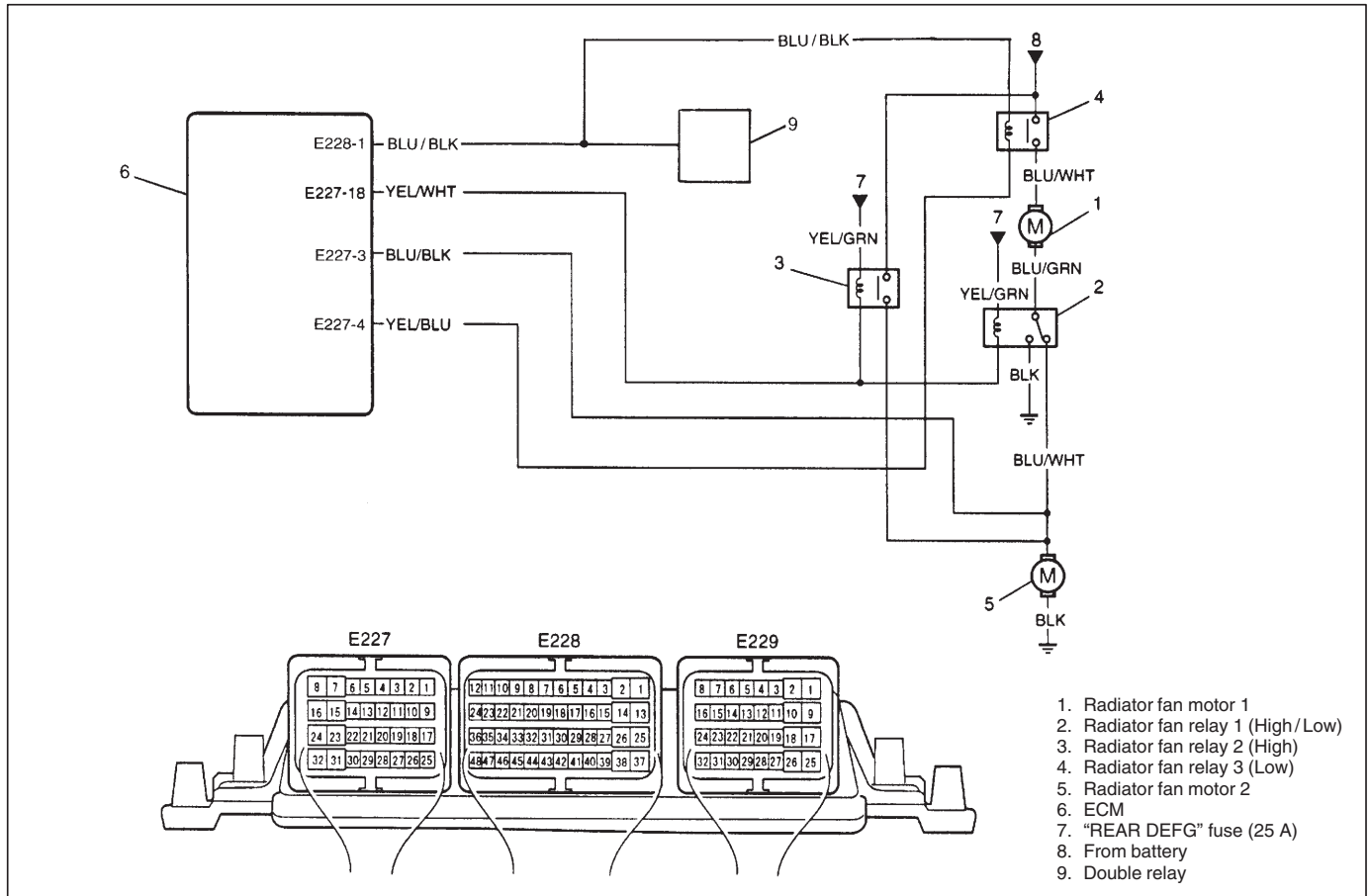

DTC CONFIRMATION PROCEDURE

- 1) Connect scan tool to DLC with ignition switch OFF.
- 2) Turn ON ignition switch and clear DTC, pending DTC and freeze frame data by using scan tool.
- 3) Start engine and warm up completely.
- 4) Check DTC and pending DTC by using scan tool.

TROUBLESHOOTING

STEP	ACTION	YES	NO
1	Was "ENGINE DIAG. FLOW TABLE" performed?	Go to Step 2.	Go to "ENGINE DIAG. FLOW TABLE".
2	Check Wire Harness 1) Disconnect connector at ECM. 2) Check voltage between E227-18 and ground with ignition switch ON. Is it about 12 V?	Poor C51-25 connection.	Go to Step 3.
3	Check Radiator Fan Relay 1) Check radiator fan relay 1 and 2 referring to Section 6E3. Are they in good condition?	<ul style="list-style-type: none"> ● "YEL/WHT" wire open or short to ground, ● "YEL/GRN" wire open or short to ground, ● Fuse broken 	Faulty radiator fan relay 1 or 2.

DTC P1109 RADIATOR FAN LOW SPEED CIRCUIT MALFUNCTION**WIRING DIAGRAM**

Refer to DTC P1108.

DTC CONFIRMATION PROCEDURE

- 1) Connect scan tool to DLC with ignition switch OFF.
- 2) Turn ON ignition switch and clear DTC, pending DTC and freeze frame data by using scan tool.
- 3) Start engine and warm up completely.
- 4) Check DTC and pending DTC by using scan tool.

TROUBLESHOOTING

STEP	ACTION	YES	NO
1	Was "ENGINE DIAG. FLOW TABLE" performed?	Go to Step 2.	Go to "ENGINE DIAG. FLOW TABLE".
2	Check Wire Harness 1) Disconnect connector at ECM. 2) Check voltage between E227-3 and ground with ignition switch ON. Is it about 12 V?	Poor E227-3 connection.	Go to Step 3.
3	Check Radiator Fan Relay 1) Check radiator fan relay 3 referring to Section 6E3. Is it in good condition?	<ul style="list-style-type: none"> ● "YEL/BLU" wire open or short to ground, ● Fuse broken 	Faulty radiator fan relay 3.

DTC P1110 A/C SIGNAL CIRCUIT MALFUNCTION WIRING DIAGRAM

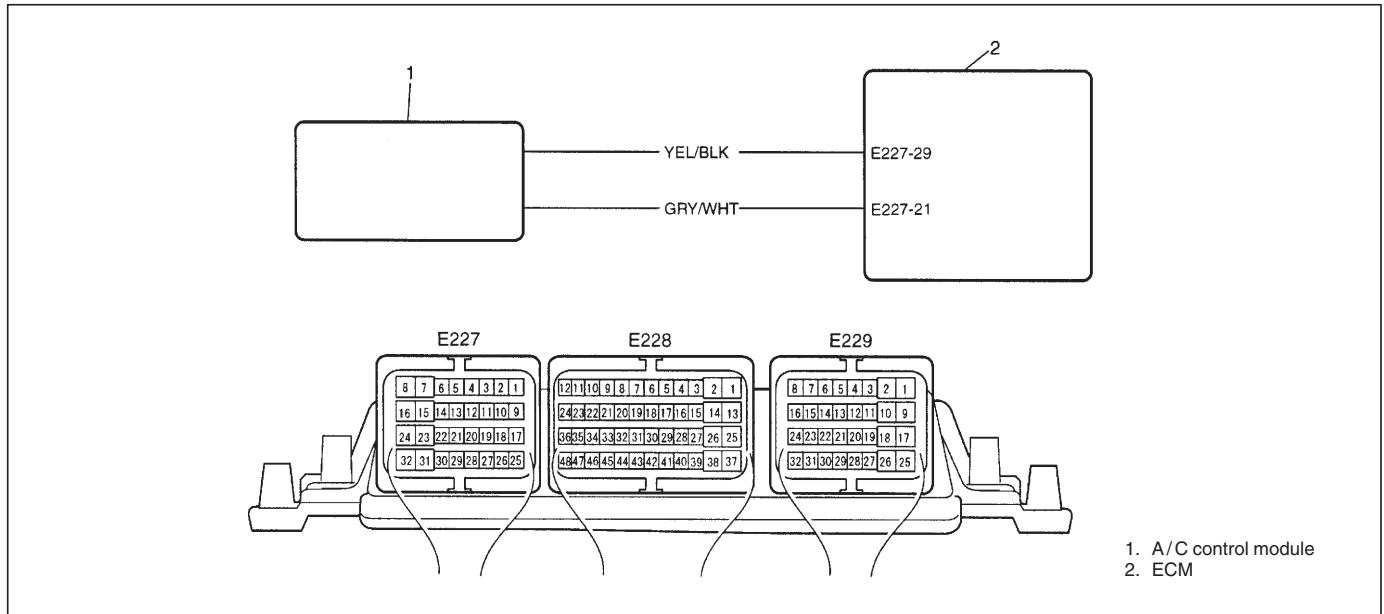

DTC CONFIRMATION PROCEDURE

- 1) Connect scan tool to DLC with ignition switch OFF.
- 2) Turn ON ignition switch and clear DTC, pending DTC and freeze frame data by using scan tool.
- 3) Start engine and turn on A/C switch and heater blower fan switch.
- 4) Check DTC and pending DTC by using scan tool.

TROUBLESHOOTING

STEP	ACTION	YES	NO
1	Was "ENGINE DIAG. FLOW TABLE" performed?	Go to Step 2.	Go to "ENGINE DIAG. FLOW TABLE".
2	<p>Check Wire Harness</p> <p>1) Remove ECM cover from ECM referring to "Voltage Check" in this section.</p> <p>2) Check voltage between E227-21 and ground at engine idling.</p> <p>Are they as follows?</p> <ul style="list-style-type: none"> ● A/C switch and heater blower switch OFF: 0 V ● A/C switch and heater blower switch ON: about 12 V 	<p>Poor E227-21 connection.</p> <p>If OK, substitute a known-good ECM and recheck.</p>	<ul style="list-style-type: none"> ● "YEL/BLK" wire open or short or ● Poor A/C control module connector connection <p>If all are in good condition, substitute a known-good A/C control module and recheck.</p>

DTC P1135 3RD PISTON DEACTIVATOR (INJECTION PUMP SOLENOID VALVE) CIRCUIT MALFUNCTION

WIRING DIAGRAM

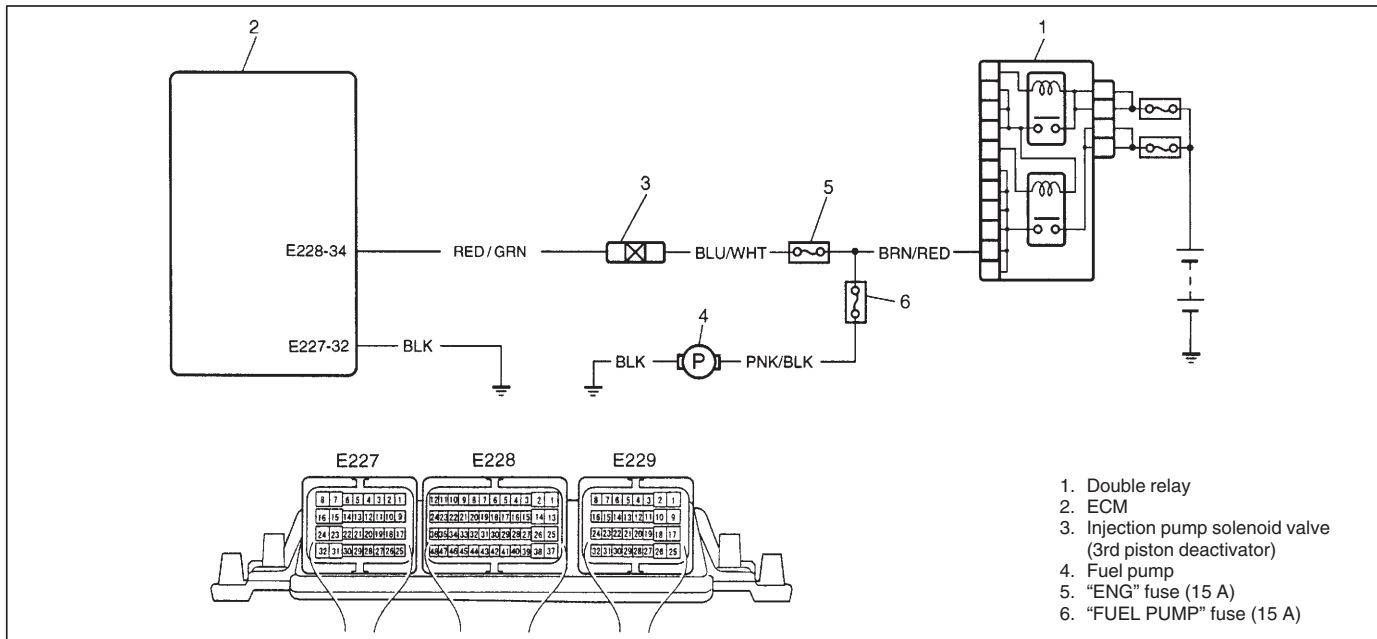

DTC CONFIRMATION PROCEDURE

- 1) Connect scan tool to DLC with ignition switch OFF.
- 2) Turn ON ignition switch and clear DTC, pending DTC and freeze frame data by using scan tool.
- 3) Run engine at idle speed.
- 4) Check DTC and pending DTC by using scan tool.

TROUBLESHOOTING

STEP	ACTION	YES	NO
1	Was "ENGINE DIAG. FLOW TABLE" performed?	Go to Step 2.	Go to "ENGINE DIAG. FLOW TABLE".
2	Is operating sound heard from fuel pump?	Go to Step 3.	Proceed to DTC P0230 Diag. Flow table.
3	Check Wire Harness 1) Disconnect injection pump solenoid valve connector with ignition switch turned OFF. 2) With ignition switch ON, check voltage between "BLU/WHT" wire terminal of solenoid valve connector and ground. • Within 5 sec. after ignition switch ON: 10 – 14 V • Over 5 sec. after ignition switch ON: about 0 V Is check result as specified?	Go to Step 4.	"BLU/WHT" wire open or short to ground.
4	Check Injector Pump Solenoid Valve Check resistance between "BLU/WHT" and "RED/GRN" terminal of valve. Is it between 25 – 30 Ω?	<ul style="list-style-type: none"> • "RED/GRN" wire open or shorted to power/ground. • Poor E228-34 connection. If wire and connection are OK, substitute a known-good ECM and recheck.	Faulty injection pump solenoid valve.

DTC P1138 (P0230) FUEL PRESSURE REGULATOR CIRCUIT MALFUNCTION WIRING DIAGRAM

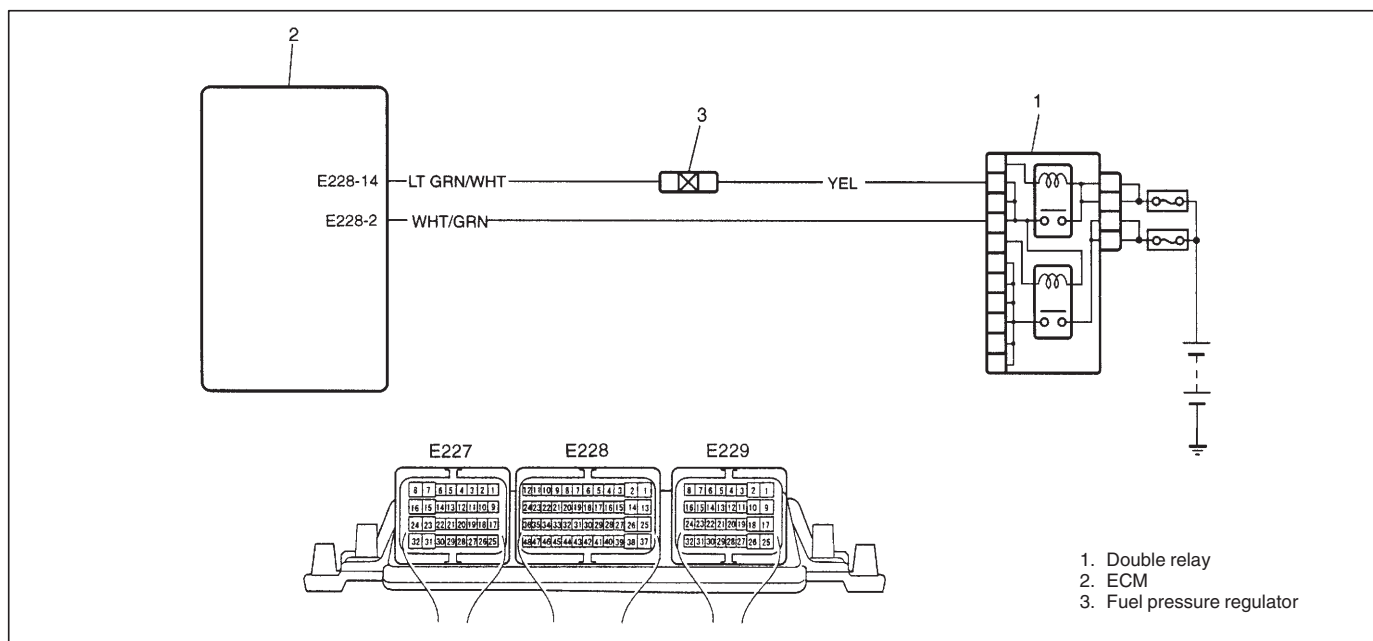

DTC CONFIRMATION PROCEDURE

- 1) Connect scan tool to DLC with ignition switch OFF.
- 2) Turn ON ignition switch and clear DTC, pending DTC and freeze frame data by using scan tool.
- 3) Run engine at idle speed for 10 sec. and stop it. Then, turn ignition switch ON.
- 4) Check DTC and pending DTC by using scan tool.

TROUBLESHOOTING

STEP	ACTION	YES	NO
1	Was "ENGINE DIAG. FLOW TABLE" performed?	Go to Step 2.	Go to "ENGINE DIAG. FLOW TABLE".
2	Check Wire Harness 1) Disconnect connector at fuel pressure regulator. 2) Check voltage between "YEL" terminal of regulator connector and ground with ignition switch ON. ● Ignition switch ON: 10 – 14 V ● Ignition switch OFF: about 0 V Is check result as specified?	Go to Step 3.	"YEL" wire open or shot to ground.
3	Check Fuel Pressure Regulator Check resistance between "YEL" and "LT GRN/WHT" terminal of valve. Is it between 2 and 3 Ω?	<ul style="list-style-type: none"> ● "LT GRN/WHT" wire open or shorted to power/ground, ● Poor E228-14 connection If wire and connection are OK, substitute a known-good ECM and recheck. (See NOTE.)	Faulty fuel pressure regulator.

NOTE:

If DTC is checked using generic scan tool only and DTC P0191 (P0230)/P1112 (P0230) Diag. Flow Table is not performed yet, go to the table before ECM replacement.

DTC P1402 (P0510) THROTTLE SOLENOID VALVE CIRCUIT MALFUNCTION

WIRING DIAGRAM

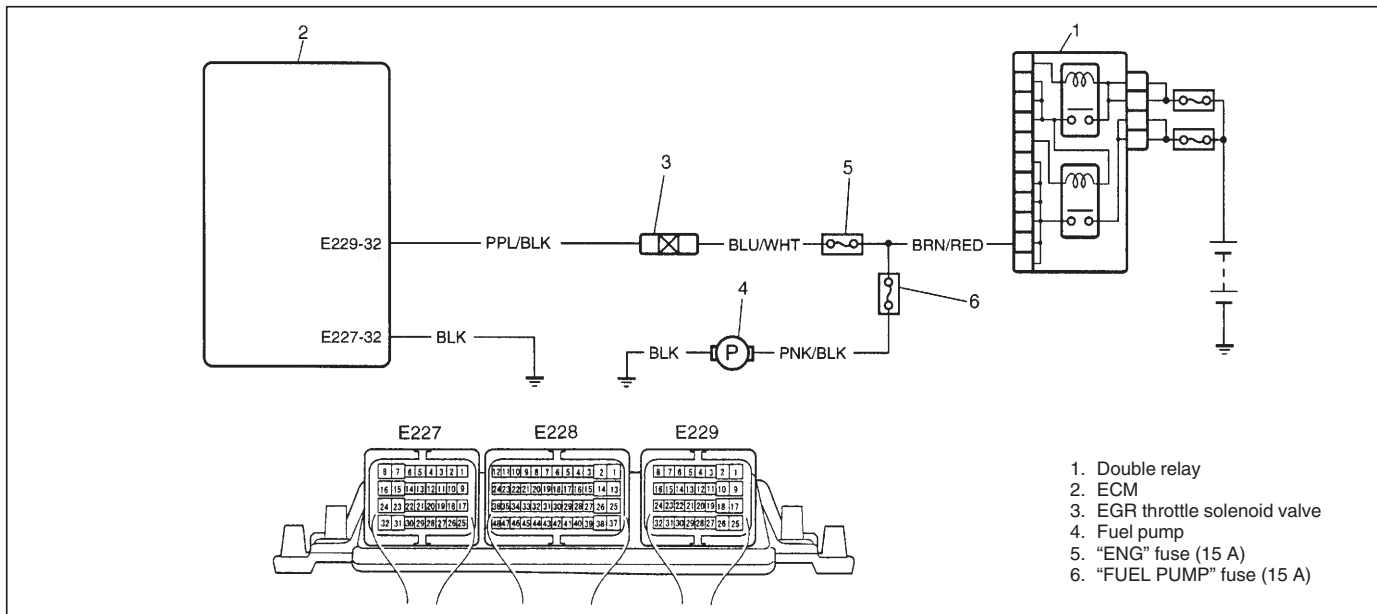

DTC CONFIRMATION PROCEDURE

- 1) Connect scan tool to DLC with ignition switch OFF.
- 2) Turn ON ignition switch and clear DTC, pending DTC and freeze frame data by using scan tool.
- 3) Turn off ignition switch and then on.
- 4) Check DTC and pending DTC by using scan tool.

TROUBLESHOOTING

STEP	ACTION	YES	NO
1	Was "ENGINE DIAG. FLOW TABLE" performed?	Go to Step 2.	Go to "ENGINE DIAG. FLOW TABLE".
2	Is operating sound heard from fuel pump?	Go to Step 3.	Proceed to DTC P0230 Diag. Flow table.
3	Check Wire Harness 1) Disconnect EGR throttle solenoid valve connector with ignition switch turned OFF. 2) With ignition switch ON, check voltage between "BLU/WHT" wire terminal of solenoid valve connector and ground. <ul style="list-style-type: none"> ● Within 5 sec. after ignition switch ON: 10 – 14 V ● Over 5 sec. after ignition switch ON: about 0 V Is check result as specified?	Go to Step 4.	"BLU/WHT" wire open, shorted to power/ground or fuse broken.
4	Check EGR Throttle Solenoid Valve 1) Check solenoid valve referring to Section 6E3. Is it in good condition?	<ul style="list-style-type: none"> ● "PPL/BLK" wire open or shorted to power/ground ● Poor E229-32 connection If wire and connection are OK, substitute a known-good ECM and recheck.	Faulty EGR solenoid valve.

DTC P1511 IGNITION SWITCH CIRCUIT MALFUNCTION WIRING DIAGRAM

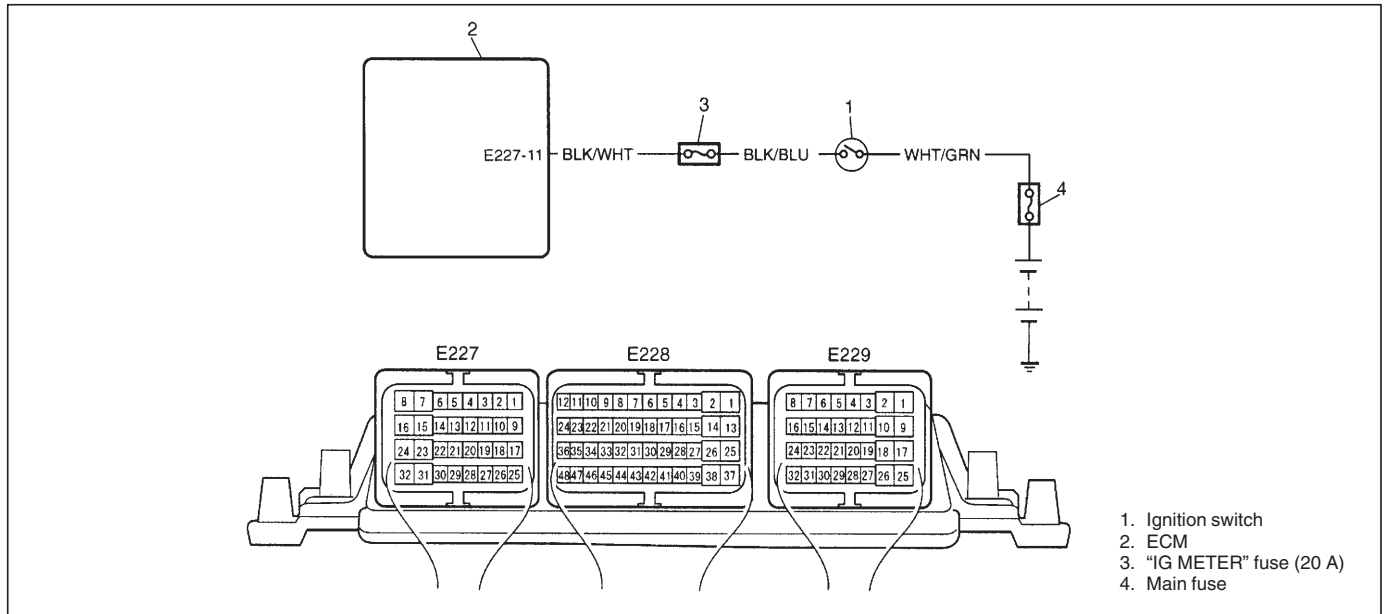

DTC CONFIRMATION PROCEDURE

- 1) Connect scan tool to DLC with ignition switch OFF.
- 2) Turn ON ignition switch and clear DTC, pending DTC and freeze frame data by using scan tool.
- 3) Turn off ignition switch and then on.
- 4) Check DTC and pending DTC by using scan tool.

TROUBLESHOOTING

STEP	ACTION	YES	NO
1	Was "ENGINE DIAG. FLOW TABLE" performed?	Go to Step 2.	Go to "ENGINE DIAG. FLOW TABLE".
2	Check Ignition Signal 1) Remove ECM cover referring to "Voltage Check" in this section. 2) Check voltage between E227-11 and ground. <ul style="list-style-type: none"> ● Ignition switch ON: 10 – 14 V ● Ignition switch OFF: 0 V Is it within specified value?	Poor E227-11 connection. If it is in good condition, substitute a known-good ECM and recheck.	"BLK/WHT" wire open or short.

DTC P1519 RADIATOR FAN CIRCUIT MALFUNCTION

WIRING DIAGRAM

Refer to DTC P1108/P1109.

TROUBLESHOOTING

Proceed to DTC P1108 and P1109 TROUBLESHOOTING.

DTC P1606 MIL CIRCUIT MALFUNCTION WIRING DIAGRAM

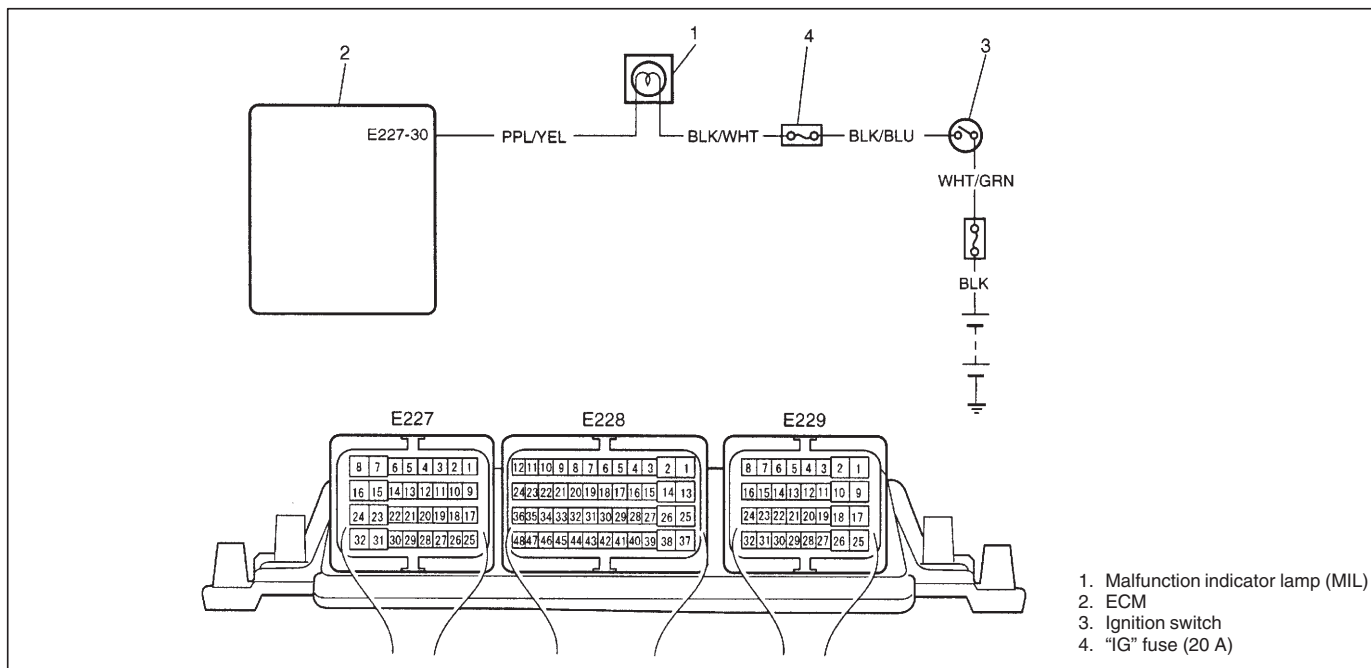

DTC CONFIRMATION PROCEDURE

- 1) Connect scan tool to DLC with ignition switch OFF.
- 2) Turn ON ignition switch and clear DTC, pending DTC and freeze frame data by using scan tool.
- 3) Turn off ignition switch and then on.
- 4) Check DTC and pending DTC by using scan tool.

TROUBLESHOOTING

STEP	ACTION	YES	NO
1	Was "ENGINE DIAG. FLOW TABLE" performed?	Go to Step 2.	Go to "ENGINE DIAG. FLOW TABLE".
2	MIL Circuit Check 1) Disconnect connector at ECM with ignition switch OFF. 2) Check voltage between "PPL/YEL" wire terminal of ECM connector and ground. • Ignition switch ON: 10 – 14 V • Ignition switch OFF: 0 V Is check result as specified?	Poor E227-30 connection. If it is in good condition, substitute a known-good ECM and recheck.	<ul style="list-style-type: none"> • "PPL/YEL" wire open or short to ground/battery or • Bulb burned out

DTC P1608 ECT WARNING LAMP CIRCUIT MALFUNCTION WIRING DIAGRAM

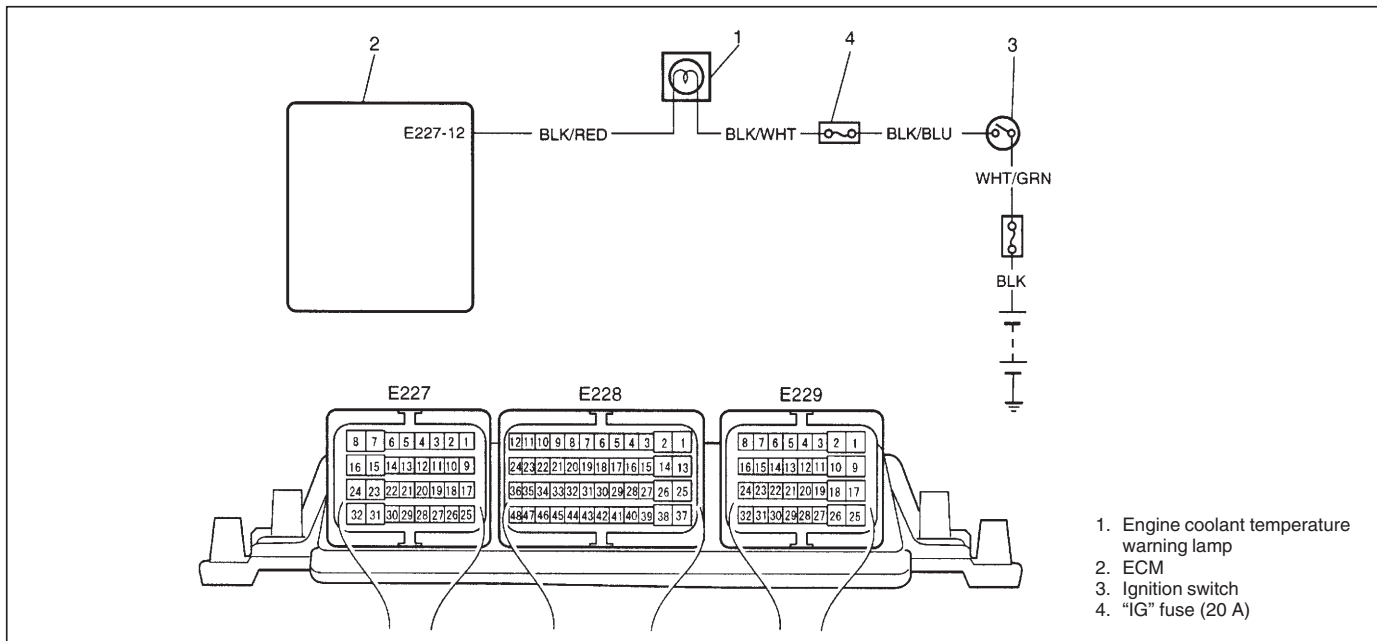

DTC CONFIRMATION PROCEDURE

- 1) Connect scan tool to DLC with ignition switch OFF.
- 2) Turn ON ignition switch and clear DTC, pending DTC and freeze frame data by using scan tool.
- 3) Turn off ignition switch and then on.
- 4) Check DTC and pending DTC by using scan tool.

TROUBLESHOOTING

STEP	ACTION	YES	NO
1	Was "ENGINE DIAG. FLOW TABLE" performed?	Go to Step 2.	Go to "ENGINE DIAG. FLOW TABLE".
2	Engine Coolant Warning Lamp Circuit Check 1) Disconnect connector at ECM with ignition switch OFF. 2) Check voltage between "BLK/RED" wire terminal of ECM connector and ground. <ul style="list-style-type: none"> ● Ignition switch ON: 10 – 14 V ● Ignition switch OFF: 0 V Is check result as specified?	Poor E227-12 connection. If it is in good condition, substitute a known-good ECM and recheck.	<ul style="list-style-type: none"> ● "BLK/RED" wire open or short to ground/battery or ● Bulb burned out

DTC P1614 (P0560) SENSOR SUPPLY FUNCTION WIRING DIAGRAM

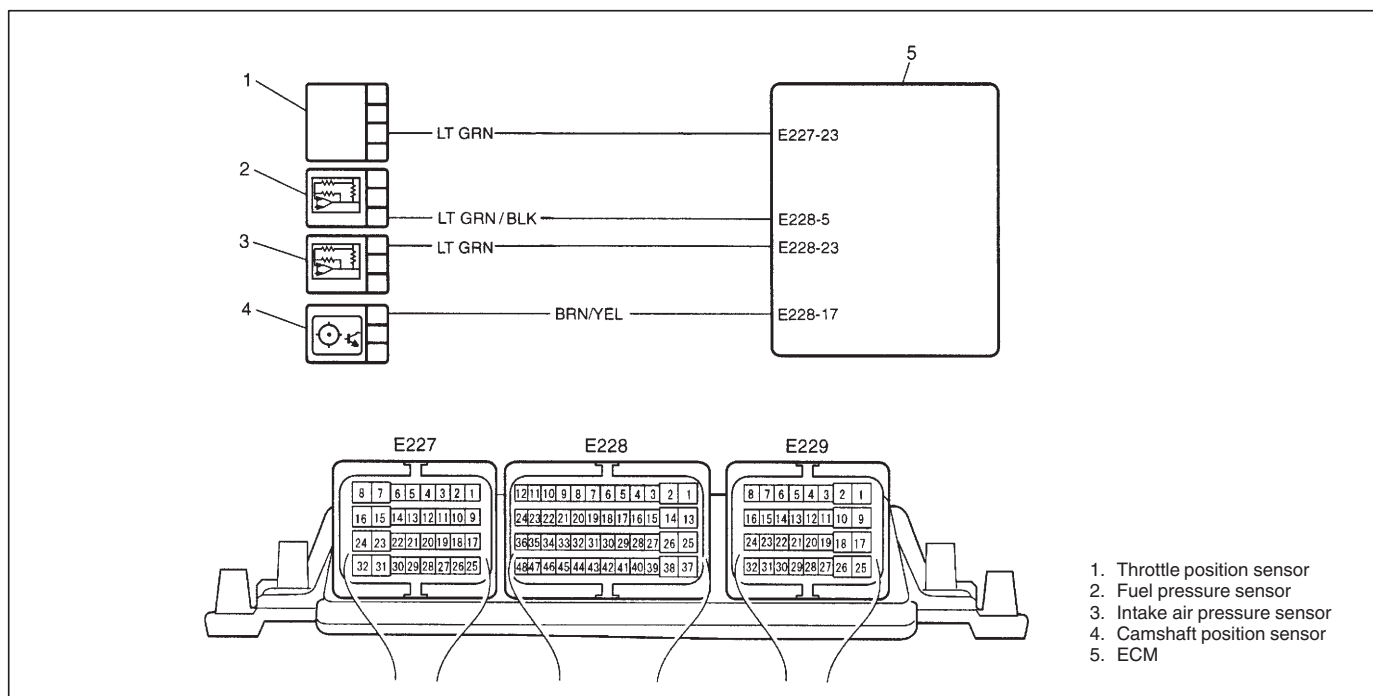

DTC CONFIRMATION PROCEDURE

- 1) Connect scan tool to DLC with ignition switch OFF.
- 2) Turn ON ignition switch and clear DTC, pending DTC and freeze frame data by using scan tool.
- 3) Check DTC and pending DTC by using scan tool.

TROUBLESHOOTING

STEP	ACTION	YES	NO
1	Was "ENGINE DIAG. FLOW TABLE" performed?	Go to Step 2.	Go to "ENGINE DIAG. FLOW TABLE".
2	Check TP Sensor Circuit 1) Disconnect connector from TP sensor with ignition switch turned OFF. 2) Turn ON ignition switch. 3) Check voltage between "LT GRN" wire terminal in TP sensor harness connector and vehicle body ground. Is voltage about 5.1 V to 4.88 V?	Go to Step 3.	"LT GRN" wire shorted to other circuits. If wire are OK, substitute a known-good ECM and recheck.
3	Check TP Sensor Circuit 1) Connect connector to TP sensor with ignition switch turned OFF. 2) Turn ON ignition switch. 3) Check voltage between "E227-23" terminal wire in ECM harness connector and vehicle body ground. Is voltage about 5.1 V to 4.88 V?	Go to Step 4.	Faulty TP sensor.

STEP	ACTION	YES	NO
4	<p>Check Fuel Pressure Sensor Circuit</p> <ol style="list-style-type: none"> 1) Disconnect connector from fuel pressure sensor with ignition switch turned OFF. 2) Turn ON ignition switch. 3) Check voltage between "LT GRN/BLK" wire terminal in fuel pressure sensor harness connector and vehicle body ground. <p>Is voltage about 5.1 V to 4.88 V?</p>	Go to Step 5.	"LT GRN/BLK" wire shorted to other circuits. If wire are OK, substitute a known-good ECM and recheck.
5	<p>Check Fuel Pressure Sensor Circuit</p> <ol style="list-style-type: none"> 1) Connect connector to fuel pressure sensor with ignition switch turned OFF. 2) Turn ON ignition switch. 3) Check voltage between "E228-5" terminal wire in ECM harness connector and vehicle body ground. <p>Is voltage about 5.1 V to 4.88 V?</p>	Go to Step 6.	Faulty fuel pressure sensor.
6	<p>Check Intake Air Pressure Sensor Circuit</p> <ol style="list-style-type: none"> 1) Disconnect connector from intake air pressure sensor with ignition switch turned OFF. 2) Turn ON ignition switch. 3) Check voltage between "LT GRN" wire terminal in intake air pressure sensor harness connector and vehicle body ground. <p>Is voltage about 5.1 V to 4.88 V?</p>	Go to Step 7.	"LT GRN" wire shorted to other circuits. If wire are OK, substitute a known-good ECM and recheck.
7	<p>Check Intake Air Pressure Sensor Circuit</p> <ol style="list-style-type: none"> 1) Connect connector to intake air pressure sensor with ignition switch turned OFF. 2) Turn ON ignition switch. 3) Check voltage between "E228-23" terminal wire in ECM harness connector and vehicle body ground. <p>Is voltage about 5.1 V to 4.88 V?</p>	Go to Step 8.	Faulty intake air pressure sensor.
8	<p>Check CMP Sensor Circuit</p> <ol style="list-style-type: none"> 1) Disconnect connector from CMP sensor with ignition switch turned OFF. 2) Turn ON ignition switch. 3) Check voltage between "BRN/YEL" wire terminal in CMP sensor harness connector and vehicle body ground. <p>Is voltage about 5.1 V to 4.88 V?</p>	Go to Step 9.	"BRN/YEL" wire shorted to other circuits. If wire are OK, substitute a known-good ECM and recheck.
9	<p>Check Intake CMP Sensor Circuit</p> <ol style="list-style-type: none"> 4) Connect connector to CMP sensor with ignition switch turned OFF. 5) Turn ON ignition switch. 6) Check voltage between "E228-17" terminal wire in ECM harness connector and vehicle body ground. <p>Is voltage about 5.1 V to 4.88 V?</p>	Faulty ECM, substitute a known-good ECM and recheck.	Faulty CMP sensor.

DTC P0221 (P0220) THROTTLE POSITION RANGE/PERFORMANCE PROBLEM 2**WIRING DIAGRAM**

Refer to DTC P0121.

DTC CONFIRMATION PROCEDURE

- 1) Connect scan tool to DLC with ignition switch OFF.
- 2) Turn ON ignition switch and clear DTC, pending DTC and freeze frame data by using scan tool.
- 3) Run engine at idle speed for 10 sec. or more.
- 4) Check DTC and pending DTC by using scan tool.

TROUBLESHOOTING

STEP	ACTION	YES	NO
1	Was "ENGINE DIAG. FLOW TABLE" performed?	Go to Step 2.	Go to "ENGINE DIAG. FLOW TABLE".
2	Check Sensor Power Supply Circuit 1) Connect scan tool to DLC with ignition switch OFF and then turn ignition switch ON. 2) Does scan tool indicate DTC as shown below? <Using Suzuki mode of Suzuki Scan tool> P1614 <Using Generic Scan tool or Euro mode of Suzuki Scan tool> P0560	Go to DTC P1614 (P0560) Diag. Flow Table.	Go to Step 3.
3	Check Wire Harness 1) Disconnect connector from TP sensor with ignition switch OFF. 2) Check for proper connection to TP sensor at each terminal. 3) If OK, then with ignition switch ON, check voltage between "LT GRN" wire and "BRN" wire terminals at connector of TP sensor. Is voltage about 5 V?	Go to Step 4.	"LT GRN" wire open, "BRN" wire open, poor E227-23 connection, or poor E227-16 connection. If wire and connection are OK, substitute a known-good ECM and recheck.
4	Check TP Sensor Output Voltage 1) Remove ECM cover referring to "Voltage Check" in this section. 2) With ignition switch ON, check voltage between E227-19 and ground, when accelerator pedal is at idle position to fully depressed position. Is voltage 0.2 – 1.6 V?	Substitute a known-good ECM and recheck.	"GRY/BLU" wire open, "GRY/BLU" wire shorted to ground/battery or poor TP sensor connector. If wire and connection are OK, substitute a known-good TP sensor and recheck.

DTC P0335 (P0335) CRANKSHAFT POSITION SENSOR CIRCUIT MALFUNCTION WIRING DIAGRAM

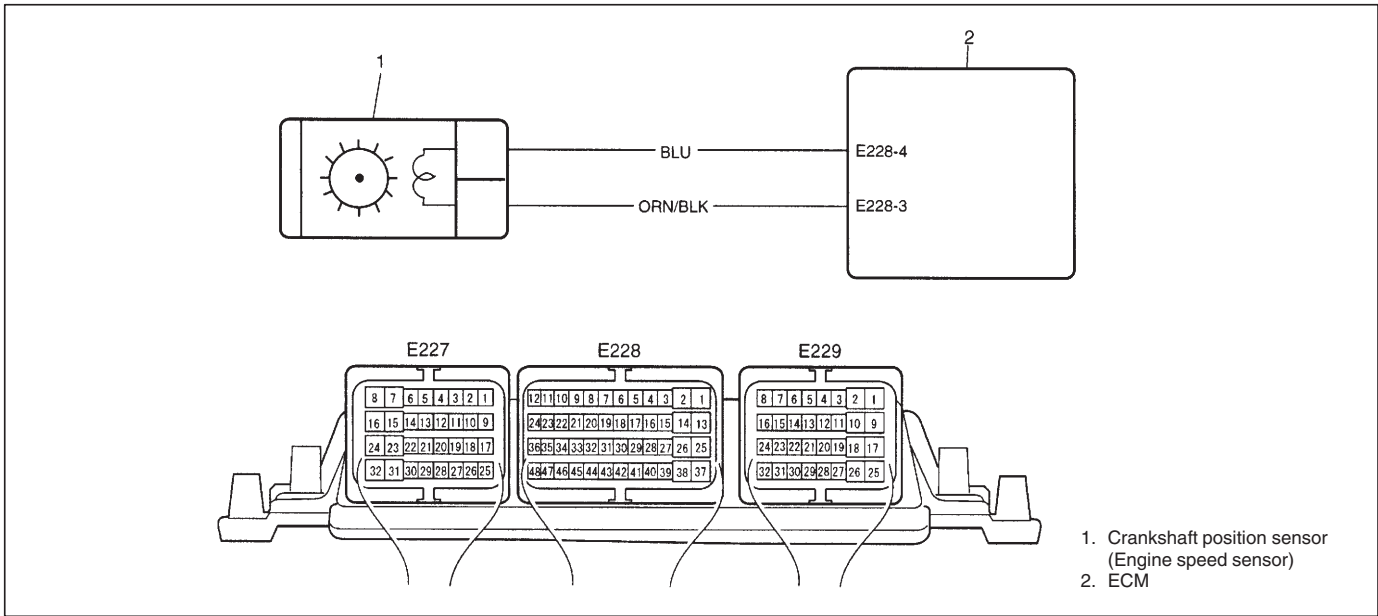

DTC CONFIRMATION PROCEDURE

- 1) Connect scan tool to DLC with ignition switch OFF.
- 2) Turn ON ignition switch and clear DTC, pending DTC and freeze frame data by using scan tool and run engine at idle speed for 10 sec.
- 3) Check DTC and pending DTC by using scan tool.

TROUBLESHOOTING

STEP	ACTION	YES	NO
1	Was "ENGINE DIAG. FLOW TABLE" performed?	Go to Step 2.	Go to "ENGINE DIAG. FLOW TABLE".
2	CKP Sensor and Its Circuit Resistance Check: 1) With ignition switch OFF, disconnect ECM coupler (E228). 2) Check for proper connection to ECM at E228-3 and E228-4 terminals. 3) If OK, check resistance of followings. Resistance between E228-3 and E228-4 terminals: 315 – 405 Ω at 20°C, 68°F Resistance between each terminal and ground: 1M Ω or more Is check result satisfactory?	Go to Step 4.	Go to Step 3.
3	CKP Sensor Resistance Check: 1) With ignition switch OFF, disconnect CKP sensor coupler and remove CKP sensor. 2) Check resistance between terminals of CKP sensor. (See Fig.) Were measured resistance values as specified in Step 2?	Faulty "ORN/BLK" wire or "BLU" wire.	Faulty CKP sensor.
4	CKP Sensor Visual Inspection: 1) Check visually CKP sensor and sensing rotor for the followings. (See Fig.) – Damage – No foreign material attached – Correct installation Are they in good condition?	Intermittent trouble or faulty ECM. Recheck for intermittent referring to "Intermittent and Poor Connection" in Section 0A. (See NOTE.)	Replace or reinstall.

NOTE:

If DTC is checked using generic scan tool only and DTC P0340 (P0335/P0340) Diag. Flow Table is not performed yet, go to the table before ECM replacement.

Fig. for Step 3

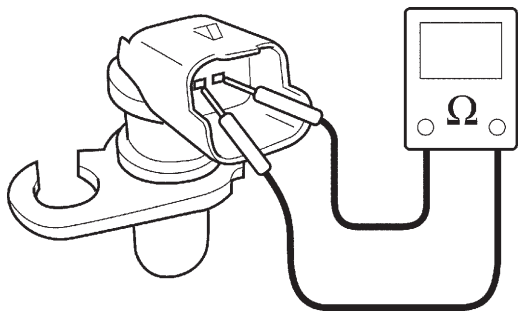

Fig. for Step 4

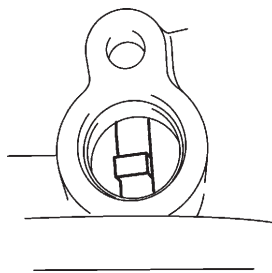
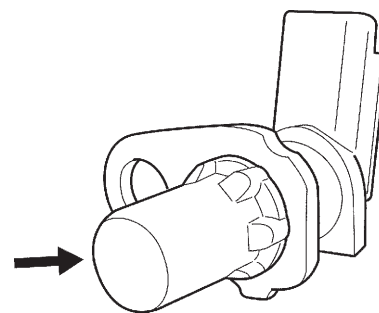
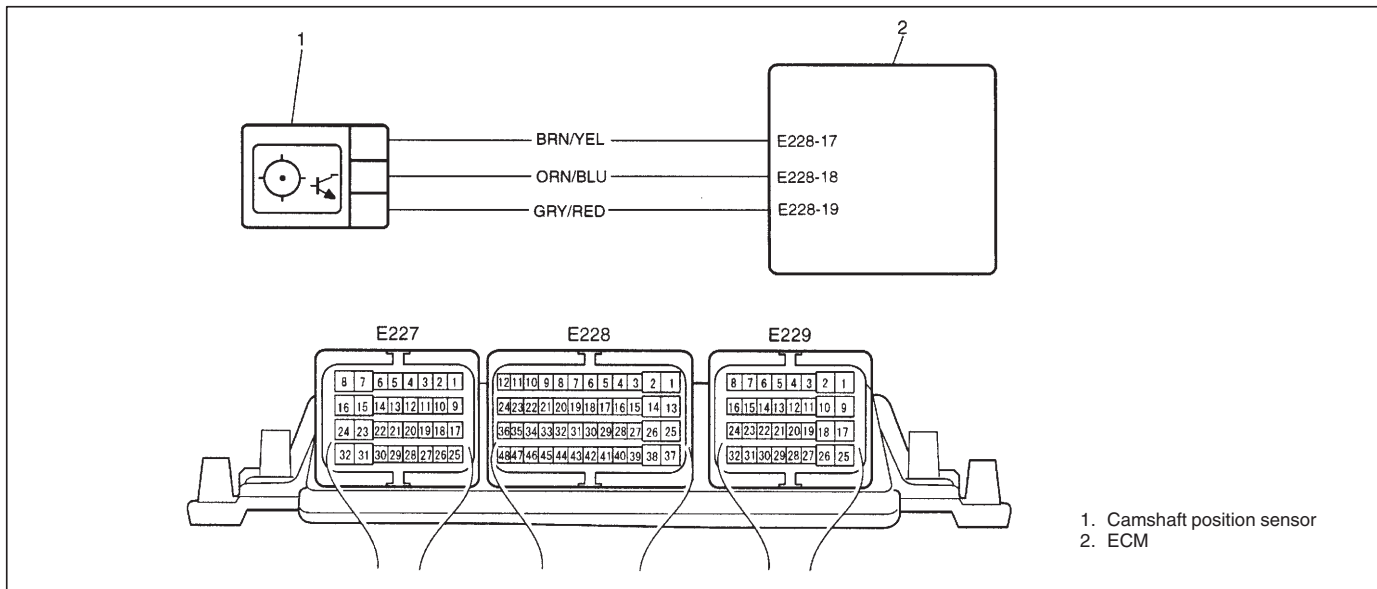

Fig. for Step 4.



DTC P0340 (P0335/P0340) CAMSHAFT POSITION SENSOR CIRCUIT MALFUNCTION WIRING DIAGRAM



DTC CONFIRMATION PROCEDURE

- 1) Connect scan tool to DLC with ignition switch OFF.
- 2) Turn ON ignition switch and clear DTC, pending DTC and freeze frame data by using scan tool.
- 3) Crank engine for 3 seconds or more and keep it at idle for 1 min. if engine start.
- 4) Check DTC and pending DTC by using scan tool.

TROUBLESHOOTING

STEP	ACTION	YES	NO
1	Was "ENGINE DIAG. FLOW TABLE" performed?	Go to Step 2.	Go to "ENGINE DIAG. FLOW TABLE".
2	Check Sensor Power Supply Circuit 1) Connect scan tool to DLC with ignition switch OFF and then turn ignition switch ON. 2) Does scan tool indicate DTC as shown below? <Using Suzuki mode of Suzuki Scan tool> P1614 <Using Generic Scan tool or Euro mode of Suzuki Scan tool> P0560	Go to DTC P1614 (P0560) Diag. Flow Table.	Go to Step 3.
3	Is engine cranked?	Go to Step 4.	Go to "CRANKING SYSTEM" section.
4	Is engine started?	Go to Step 5.	Check CKP sensor (Engine speed sensor) and its circuit according to DTC P0335 (P0335) Diag. Flow Table.
5	Check CMP Sensor and connector for proper installation. Is CMP sensor installed properly and connector connected securely?	Go to Step 6.	Correct.

STEP	ACTION	YES	NO
6	Check Wire Harness and Connection. 1) Disconnect connector from CMP sensor. 2) Check for proper connection to CMP sensor at each terminal. 3) If OK, turn ignition switch ON and check for voltage between "ORN/BLU" and "GRY/RED" terminals of sensor connector disconnected. Is voltage 10 – 14 V?	Go to Step 7.	"ORN/BLU" or "GRY/RED" wire open, short or poor connection.
7	Check for voltage between "BRN/YEL" and "GRY/RED" terminals of sensor connector disconnected. Is voltage about 5 V?	Go to Step 8.	"BRN/YEL" wire open, short or poor connection. If wire and connection are OK, substitute a known-good ECM and recheck. (See NOTE).
8	Check Camshaft Hub 1) Remove upper timing belt cover. 2) Check camshaft hub for the following. • Damage • No foreign material attached Is it in good condition?	Check CMP sensor air gap referring to Section 6E3. If check result is OK, substitute a known-good CMP sensor and recheck.	Clean surfaces of camshaft hub or replace camshaft hub.

NOTE:

If DTC is checked using generic scan tool only and DTC P0335 (P0335) Diag. Flow Table is not performed yet, go to the table before ECM replacement.

Fig. for Step 6 and 7

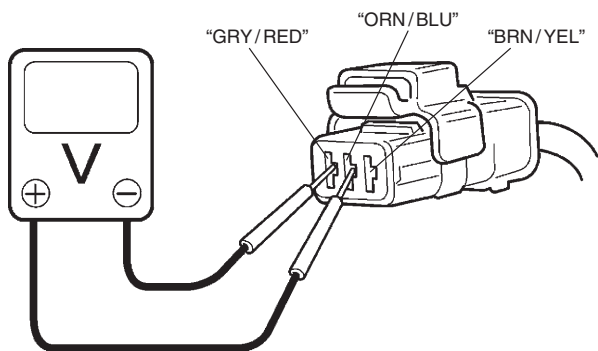

DTC P0500 (P0500) VEHICLE SPEED SENSOR CIRCUIT MALFUNCTION WIRING DIAGRAM

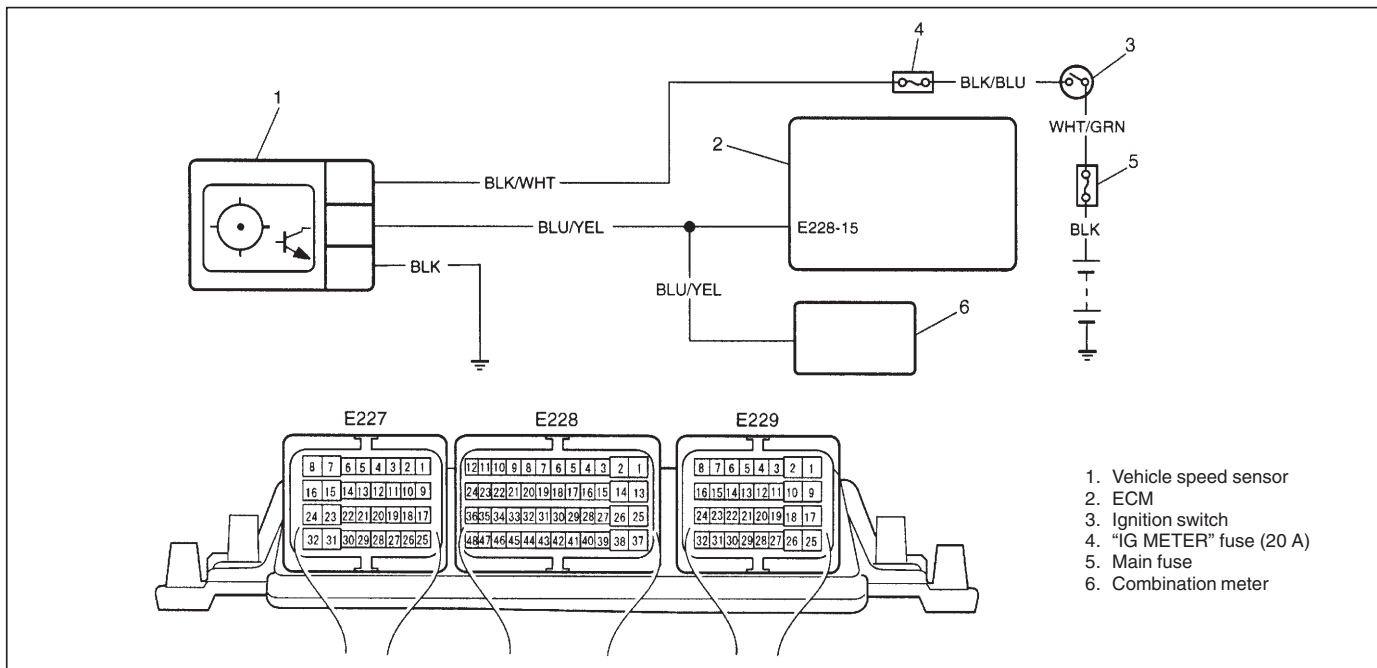

DTC CONFIRMATION PROCEDURE

WARNING:

- When performing a road test, select a place where there is no traffic or possibility of a traffic accident and be very careful during testing to avoid occurrence of an accident.
- Road test should be carried out with 2 persons, a driver and a tester, on a level road.

- 1) Connect scan tool to DLC with ignition switch OFF.
- 2) Turn ON ignition switch and clear DTC, pending DTC and freeze frame data by using scan tool and warm up engine completely.
- 3) Increase vehicle speed to 100 – 110 km/h (60 – 70 mph).
- 4) Release accelerator pedal and with engine brake applied, keep vehicle coasting and then stop vehicle.
- 5) Check DTC and pending DTC by using scan tool.

TROUBLESHOOTING

STEP	ACTION	YES	NO
1	Was "ENGINE DIAG. FLOW TABLE" performed?	Go to Step 2.	Go to "ENGINE DIAG. FLOW TABLE".
2	Does speedometer indicate vehicle speed?	Faulty "BLU/YEL" wire or poor E228-15 connection. If wire and connection are OK, intermittent trouble or faulty ECM. Check for intermittent referring to "Intermittent and Poor Connection" in Section 0A.	Go to Step 3.
3	VSS Power Supply Voltage Check: 1) With ignition switch OFF, remove VSS coupler. 2) With ignition switch ON leaving engine OFF, check voltage between "BLK/WHT" wire terminal and "BLK" wire terminal of VSS coupler. Is voltage 10 – 14 V?	Go to Step 4.	"BLK/WHT" or "BLK" wire open/short.
4	VSS Signal Harness Check: 1) With ignition switch ON leaving engine OFF, check voltage between "BLU/YEL" wire terminal and "BLK" wire terminal of VSS coupler. Is voltage 4 V or more?	Go to Step 5.	Go to Step 6.
5	VSS Visual Inspection: 1) Remove VSS referring to "TRANSFER" section. 2) Check VSS drive and driven gears for damage and excessive wear. Are they in good condition?	Poor VSS connection or VSS malfunction. If connection is OK, substitute a known-good VSS and recheck.	Replace VSS.
6	Speedometer Circuit Check: 1) With ignition switch OFF, disconnect G11 coupler from combination meter. 2) With ignition switch ON leaving engine OFF, check voltage between "BLU/YEL" wire terminal and "BLK" wire terminal of VSS coupler. Is voltage 4 V or more?	Substitute a known-good combination meter and recheck.	"BLU/YEL" wire open/short or faulty ECM. If wire and connection are OK, substitute a known-good ECM and recheck.

DTC P0235 (P0235) INTAKE AIR PRESSURE SENSOR CIRCUIT MALFUNCTION WIRING DIAGRAM

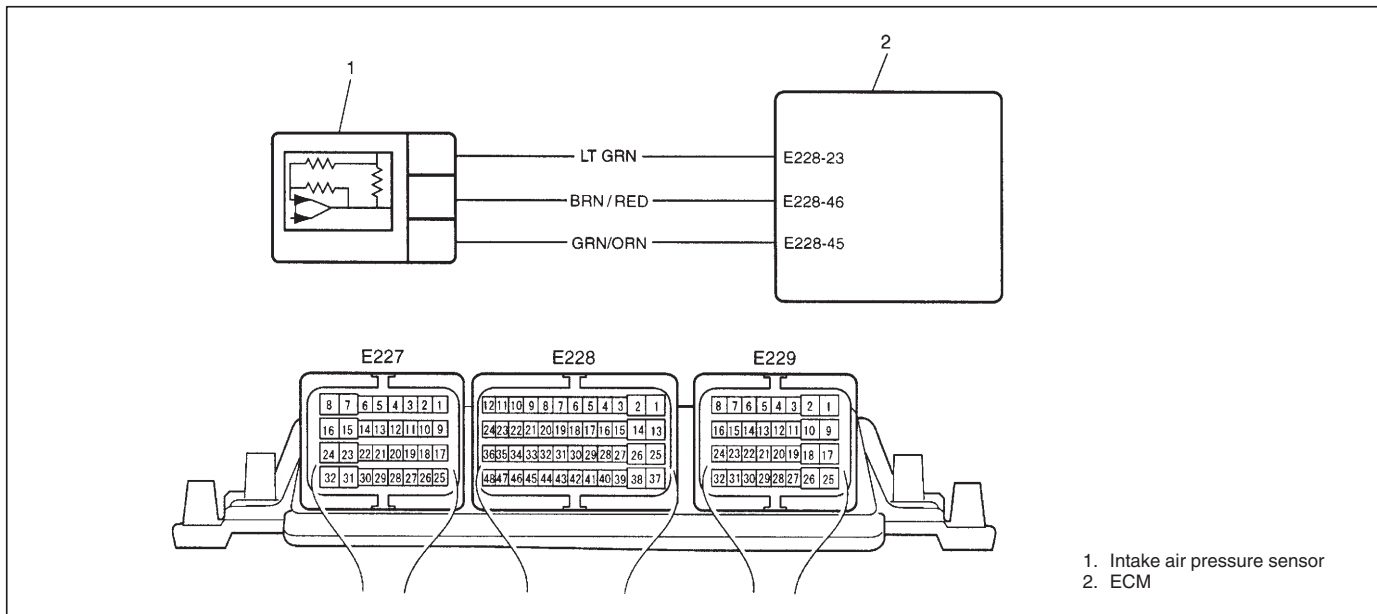

DTC CONFIRMATION PROCEDURE

WARNING:

- When performing a road test, select a place where there is no traffic or possibility of a traffic accident and be very careful during testing to avoid occurrence of an accident.
- Road test should be carried out with 2 persons, a driver and a tester, on a level road.

NOTE:

Check to make sure that the following conditions are satisfied when using this DTC CONFIRMATION PROCEDURE.

- Intake air temp.: 5°C, 41°F or higher
- Engine coolant temp.: -8 – 110°C (18 – 230°F)
- Altitude (barometric pressure): 2400 m, 8000 ft or less (560 mmHg, 75 kPa or more)

- 1) Connect scan tool to DLC with ignition switch OFF.
- 2) Turn ON ignition switch and clear DTC, pending DTC and freeze frame data by using scan tool.
- 3) Run engine at idle speed for 10 sec or more.
- 4) Check DTC and pending DTC by using scan tool.

TROUBLESHOOTING

STEP	ACTION	YES	NO
1	Was "ENGINE DIAG. FLOW TABLE" performed?	Go to Step 2.	Go to "ENGINE DIAG. FLOW TABLE".
2	<p>Check Sensor Power Supply Circuit</p> <p>1) Connect scan tool to DLC with ignition switch OFF and then turn ignition switch ON.</p> <p>2) Does scan tool indicate DTC as shown below?</p> <p><Using Suzuki mode of Suzuki Scan tool> P1614</p> <p><Using Generic Scan tool or Euro mode of Suzuki Scan tool> P0560</p>	Go to DTC P1614 (P0560) Diag. Flow Table.	Go to Step 3.
3	<p>Intake Air Pressure Sensor Signal Check:</p> <p>1) Remove ECM cover referring to "Voltage Check" in this section.</p> <p>2) Check voltage E228-45 and ground with ignition switch ON.</p> <p>Is it between 1 and 5 V?</p>	Intermittent trouble or faulty ECM. Check for intermittent referring to "Intermittent and Poor Connection" in Section 0A.	Go to Step 4.
4	<p>Intake Air Pressure Sensor Check:</p> <p>1) Disconnect connector from intake air pressure sensor.</p> <p>2) Check for proper connection to intake air pressure sensor at each terminal.</p> <p>3) If OK, check intake air pressure sensor for performance referring to "Intake Air Pressure Sensor Inspection" in Section 6E3.</p> <p>Is check result satisfactory?</p>	"LT GRN", "BRN" or "GRN/ORN" circuit open/short. If wire and connections are OK, substitute a known-good ECM and recheck.	Replace intake air pressure sensor.

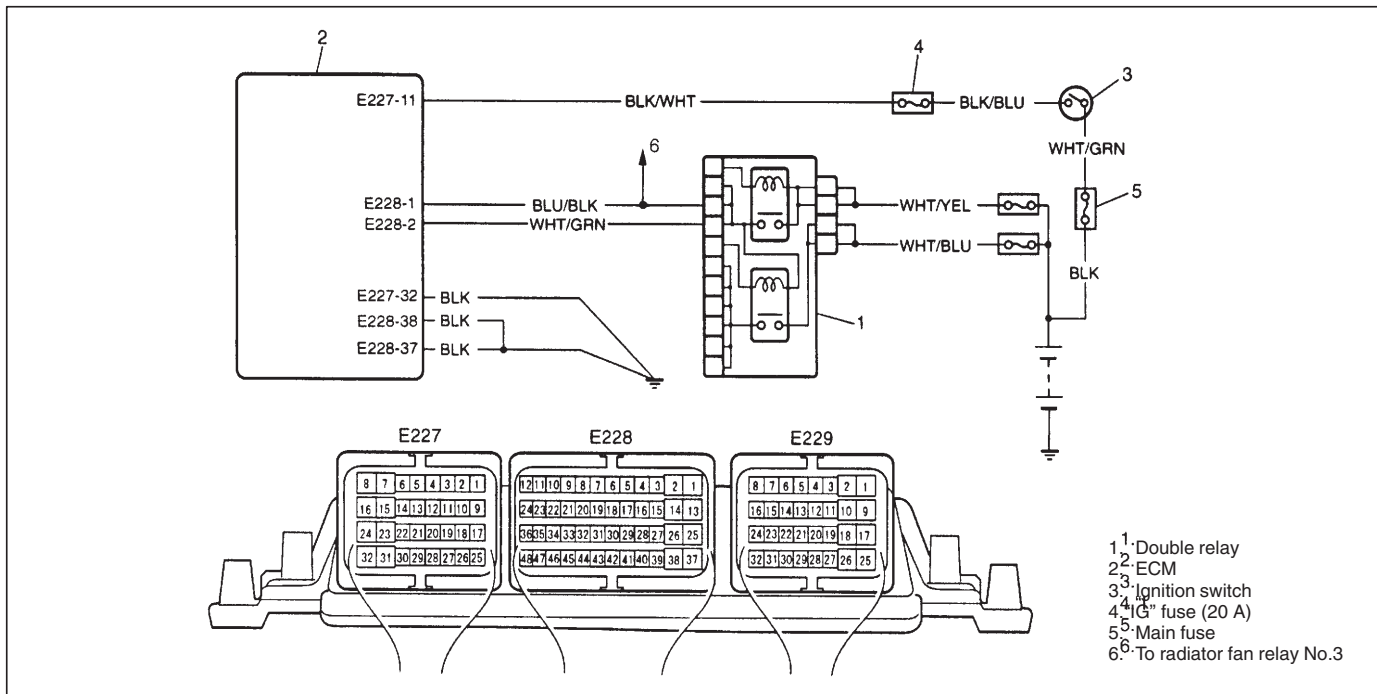
DTC P0560 (P0560) POWER SUPPLY CIRCUIT MALFUNCTION**WIRING DIAGRAM****DTC CONFIRMATION PROCEDURE**

- 1) Connect scan tool to DLC with ignition switch OFF.
- 2) Turn ON ignition switch and clear DTC/pending DTC and freeze frame data by using scan tool and run engine at idle speed for 1 min.
- 3) Check DTC and pending DTC by using scan tool.

TROUBLESHOOTING (DTC P1500)

STEP	ACTION	YES	NO
1	Was "ENGINE DIAG. FLOW TABLE" performed?	Go to Step 2.	Go to "ENGINE DIAG. FLOW TABLE".
2	<ol style="list-style-type: none"> 1) Remove ECM cover referring to "Voltage Check" in this section. 2) While engine running, check voltage between following terminals. E227-11 and ground E228-1 and ground E228-2 and ground Is each voltage between 7 and 17.5 V? 	Intermittent trouble. Check for intermittent referring to "INTERMITTENT AND POOR CONNECTION" in Section 0A. If wire and connections are OK, substitute a known-good ECM and recheck. (See NOTE.)	"BLK/WHT", "BLU/BLK" or "WHT/GRN" circuit open or short.

NOTE:

If DTC is checked using generic scan tool only and P1614 (P0560) Diag. Flow Table is not performed yet, go to the table before ECM replacement.

TABLE B-1 FUEL PUMP CIRCUIT INSPECTION WIRING DIAGRAM

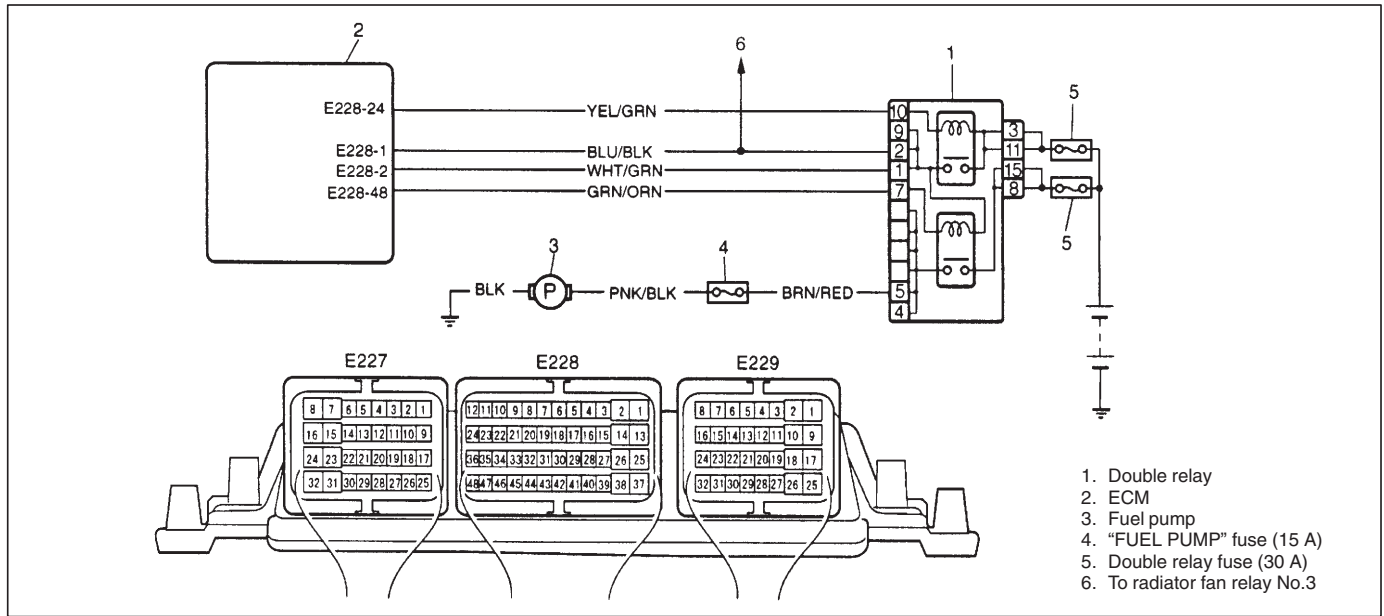

INSPECTION

STEP	ACTION	YES	NO
1	Fuel Pump Operation Check: 1) Turn ON ignition switch. Is fuel pump operation sound heard for 5 sec. after ignition switch ON?	Fuel pump circuit is in good condition.	Go to Step 2.
2	Fuel Pump Circuit Check: 1) With ignition switch OFF, remove double relay from connector. 2) Check for proper connection to relay at each terminal. 3) If OK, using service wire, connect terminals 8 and 5 of relay connector. <div style="border: 1px solid black; padding: 5px; width: fit-content; margin: 10px auto;"> <p>CAUTION: Check to make sure that connection is made between correct terminals. Wrong connection can cause damage to ECM, wire harness etc.</p> </div> Is fuel pump heard to operate at ignition switch ON?	Go to Step 3.	"BLK", "PNK/BLK" or "BRN/RED" circuit open or fuel pump malfunction.
3	Double Relay Check: 1) Check fuel pump relay referring to "Double Relay Inspection" in Section 6E3. Is it in good condition?	"GRN/ORN" circuit open.	Replace fuel pump.

**TABLE B-2 FUEL PRESSURE INSPECTION
SYSTEM DIAGRAM**

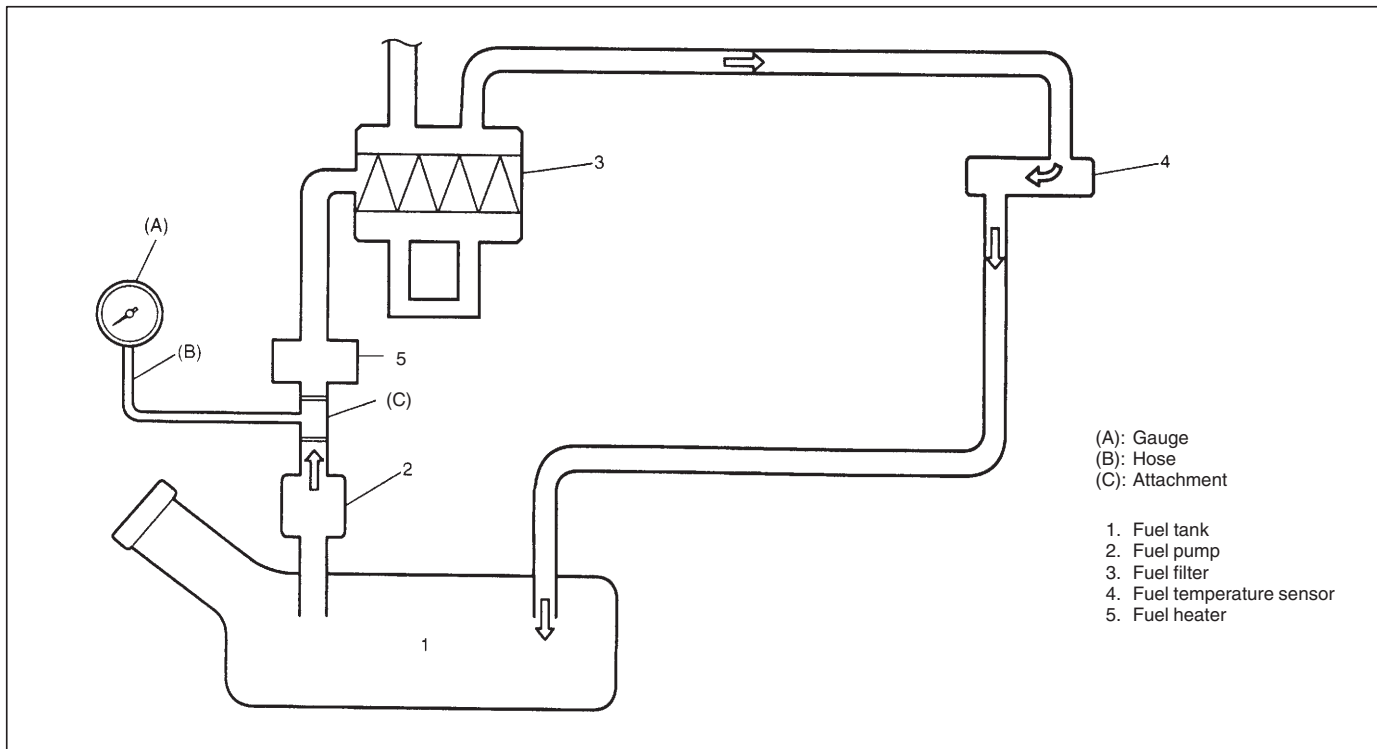

INSPECTION

NOTE:

Before using following flow table, check to make sure that battery voltage is higher than 11 V. If battery voltage is low, pressure becomes lower than specification even if fuel pump and line are in good condition.

STEP	ACTION	YES	NO
1	1) Install fuel pressure gauge, referring to "Low Pressure Fuel Supply System Inspection" in Section 6E3. 2) Operate fuel pump. Is fuel pressure then about 220 kPa (2.2 kg/cm ² , 31.3 psi)?	Normal fuel pressure.	Go to Step 2.
2	Was fuel pressure higher than spec. in Step 1?	Clogged fuel heater, fuel filter fuel temperature or fuel hose/pipe.	Go to Step 3.
3	Was no fuel pressure applied in Step 1?	<ul style="list-style-type: none"> ● Shortage of fuel or ● Fuel pump and its circuit defective. (Refer to Table B-1 "Fuel Pump Circuit Inspection".)	Fuel leakage from fuel line.

SPECIAL TOOLS

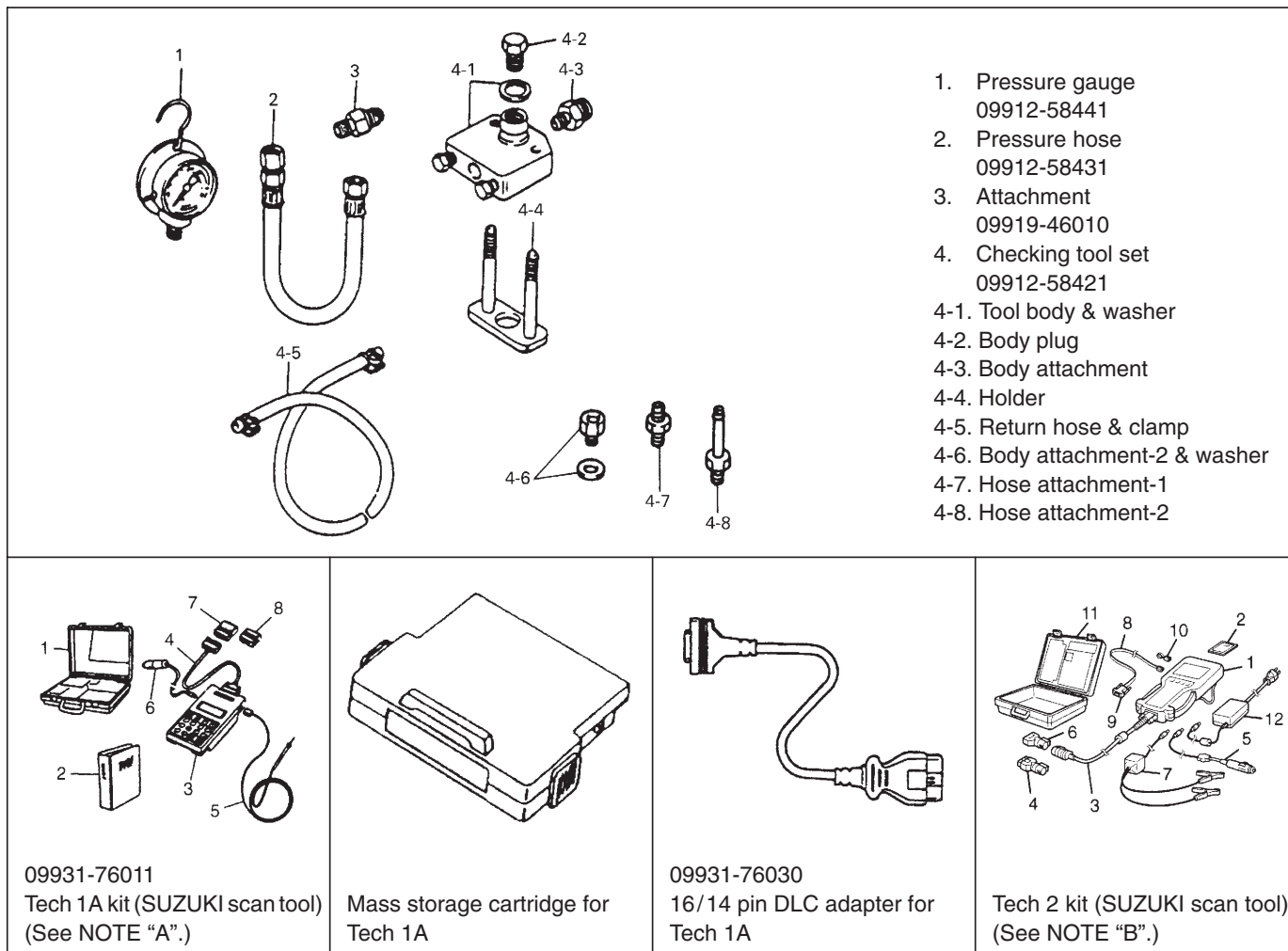

NOTE:

- "A": This kit includes the following items and substitutes for the Tech 2 kit.
 1. Storage case, 2. Operator's manual, 3. Tech 1A, 4. DLC cable (14/26 pin, 09931-76040), 5. Test lead/probe, 6. Power source cable, 7. DLC cable adaptor, 8. Self-test adaptor
- "B": This kit includes the following items and substitutes for the Tech 1A kit.
 1. Tech 2, 2. PCMCIA card, 3. DLC cable, 4. SAE 16/19 adapter, 5. Cigarette cable, 6. DLC loopback adaptor, 7. Battery power cable, 8. RS232 cable, 9. RS232 adaptor, 10. RS232 loopback connector, 11. Storage case, 12. Power supply

SECTION 6A3

ENGINE MECHANICAL (RHZ ENGINE)

WARNING:

For vehicles equipped with Supplemental Restraint (Air Bag) System:

- Service on and around the air bag system components or wiring must be performed only by an authorized SUZUKI dealer. Refer to “Air Bag System Components and Wiring Location View” under “General Description” in air bag system section in order to confirm whether you are performing service on or near the air bag system components or wiring. Please observe all WARNINGS and “Service Precautions” under “On-Vehicle Service” in air bag system section before performing service on or around the air bag system components or wiring. Failure to follow WARNINGS could result in unintentional activation of the system or could render the system inoperative. Either of these two conditions may result in severe injury.
- Technical service work must be started at least 90 seconds after the ignition switch is turned to the “LOCK” position and the negative cable is disconnected from the battery. Otherwise, the system may be activated by reserve energy in the Sensing and Diagnostic Module (SDM).

6A3

CAUTION:

Be sure to read “Precaution” in Section 6E before disconnecting fuel line or removing fuel system part(s). Failure to follow “Precaution” could result in unneeded fuel system repairs.

CONTENTS

MAINTENANCE	6A3- 2
Oil Level Check, Oil Change and Oil Filter Change	6A3- 2
ON-VEHICLE SERVICE	6A3- 2
Compression Check	6A3- 2
Air Cleaner Element	6A3- 3
Cylinder Head Cover	6A3- 4
Intake Manifold	6A3- 6
Exhaust Manifold	6A3- 7
Timing Belt and Belt Tensioner (Engine with Camshaft Hub)	6A3- 8
Timing Belt and Belt Tensioner (Engine without Camshaft Hub)	6A3-14
Oil Pressure Switch	6A3-20
Oil Cooler	6A3-20
Oil Pan and Oil Pump Strainer	6A3-21
Oil Pump	6A3-26
Camshaft and Valve Lash Adjusters	6A3-30
Valves and Cylinder Head	6A3-32
Piston, Piston Rings, Connecting Rods and Cylinders	6A3-42
UNIT REPAIR OVERHAUL	6A3-47
Engine Assembly	6A3-47
Main Bearings, Crankshaft and Cylinder Block	6A3-50
SPECIAL TOOLS	6A3-57
REQUIRED SERVICE MATERIALS	6A3-58
TIGHTENING TORQUE SPECIFICATION	6A3-59

NOTE:

For what each abbreviation stands for (i.e., full term), refer to SECTION 0A.

MAINTENANCE

OIL LEVEL CHECK, OIL CHANGE AND OIL FILTER CHANGE

Refer to "ENGINE" in Section 0B.

ON-VEHICLE SERVICE

COMPRESSION CHECK

- 1) Cool off engine if it is hot.
- 2) Disconnect negative cable at battery.
- 3) Disconnect ECM connector from ECM.
- 4) Remove all glow plugs referring to "GLOW PLUG" in Section 6E3.
- 5) Install special tool to glow plug hole.

Special Tool

(A): 09912-57820

(B): 09916-96520

- 6) Connect negative cable at battery.
- 7) Disengage clutch (to lighten starting load on engine) for M/T vehicle.
- 8) Crank engine and inspect compression pressure.

Compression pressure specification

(at cranking engine (engine speed is 250 rpm or more)):

Minimum: 2.5 MPa (25 kg/cm², 356 psi)

Maximum difference between cylinders:

0.5 MPa (5 kg/cm², 72 psi)

- 9) Perform above check for each cylinder.

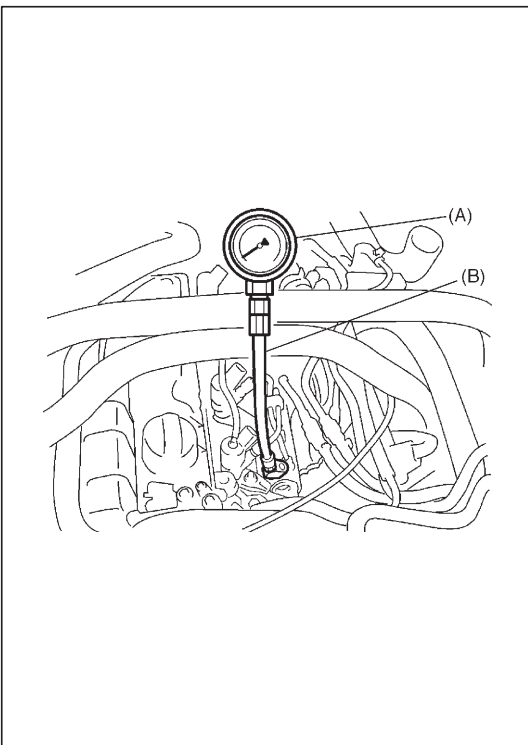

- 10) If compression in one or more cylinders is low, pour a small amount of engine oil into the cylinder and recheck compression.
 - If compression increases, piston, piston rings or cylinder wall may be worn.
 - If compression stays low, valve may be stuck or seating improperly.
 - If compression in adjacent cylinders stays low, cylinder head gasket may be damaged or cylinder head distorted.

- 11) Disconnect negative cable at battery.
- 12) Remove special tool and install all glow plugs referring to "GLOW PLUG" in Section 6E3.
- 13) Connect ECM connector to ECM.
- 14) Connect negative cable at battery.

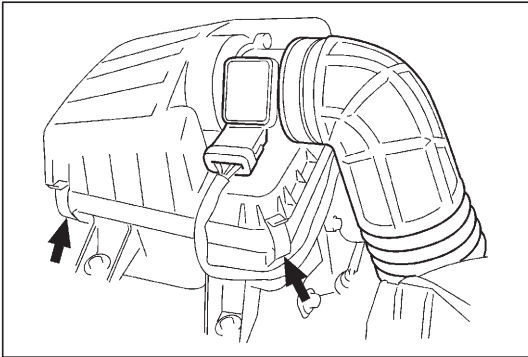

AIR CLEANER ELEMENT REMOVAL

- 1) Remove air cleaner case clamps.
- 2) Remove air cleaner element from case.

INSPECTION

Check air cleaner element for dirt. Replace excessively dirty element.

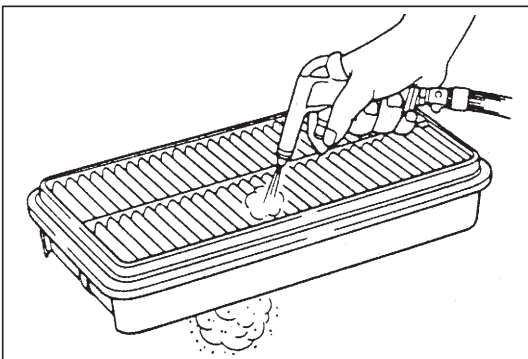

CLEAN

Blow off dust by compressed air from air outlet side of element.

INSTALLATION

Reverse removal procedure for installation.

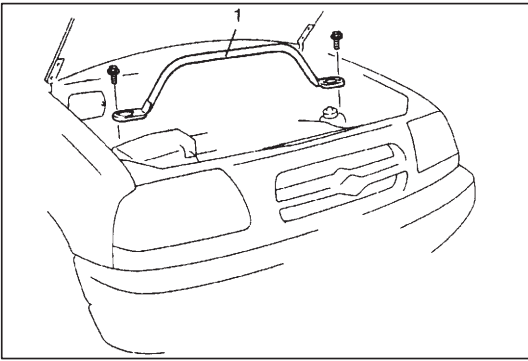

CYLINDER HEAD COVER

REMOVAL

- 1) Disconnect negative cable at battery.
- 2) Remove TP sensor (Accelerator stroke sensor) from air cleaner case and intake air pressure sensor from strut tower bar.
- 3) Remove strut tower bar (1).
- 4) Remove intercooler and intercooler inlet hose referring to "INTERCOOLER" in Section 6E3.

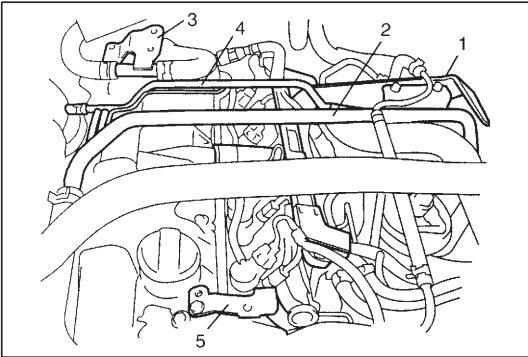

- 5) Remove intercooler bracket (1), heater outlet pipe (2), heater inlet pipe (3), vacuum pipe (4) and bracket (5).
- 6) Remove upper timing belt cover.

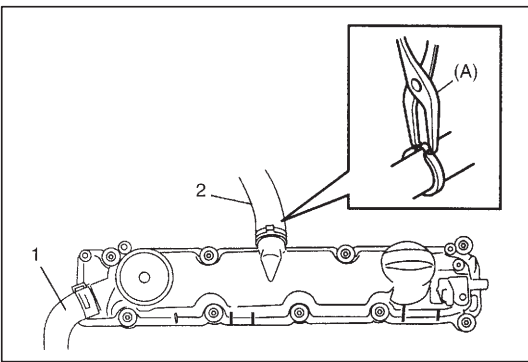

- 7) Disconnect breather hose (1) and PCV hose (2) from cylinder head cover.

Special Tool

(A): 09919-46510/OUT0000110

- 8) Disconnect CMP sensor connector. Remove CMP sensor, if necessary.

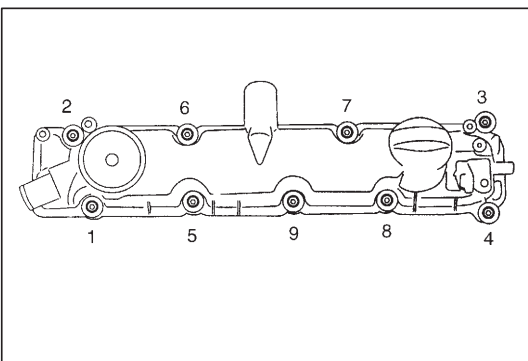

- 9) Loosen cylinder head cover bolts in such order as indicated in figure and remove them.
- 10) Remove cylinder head cover with its gasket.

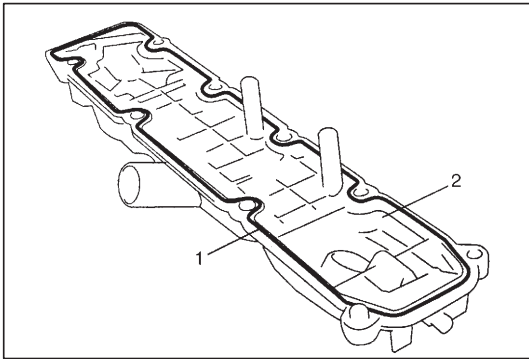

INSTALLATION

- 1) Install cylinder head cover gasket (1) to cylinder head cover (2).

NOTE:

Be sure to check cylinder head cover gasket for deterioration or any damage before installation and replace if found defective.

- 2) Install cylinder head cover to cylinder head.

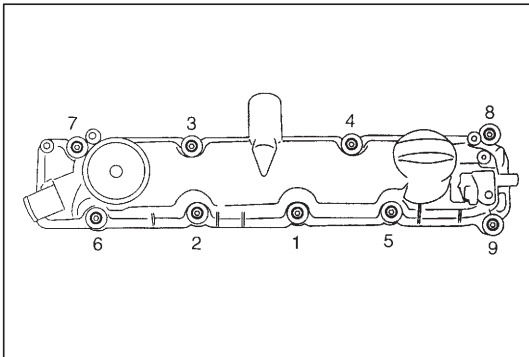

- 3) Tighten bolts in such order as indicated in figure a little at a time till they are tightened to specified torque.

Tightening Torque

Cylinder head cover bolt: 10 N·m (1.0 kg-m, 7.5 lb-ft)

NOTE:

When installing cylinder head cover, use care so that cylinder head cover gasket will not get out of place or fall off.

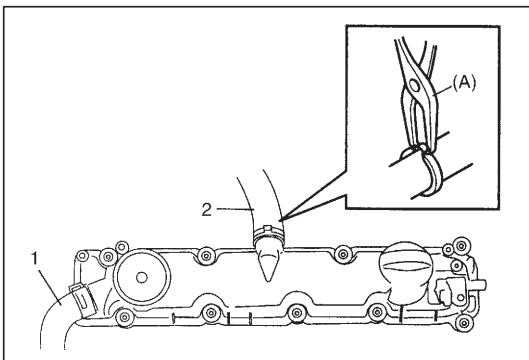

- 4) Connect breather hose (1) and PCV hose (2) to cylinder head cover.

Special Tool

(A): 09919-46510/OUT0000110

- 5) Install CMP sensor, if removed.
- 6) Check CMP sensor air gap referring to "CAMSHAFT POSITION SENSOR" in Section 6E3.

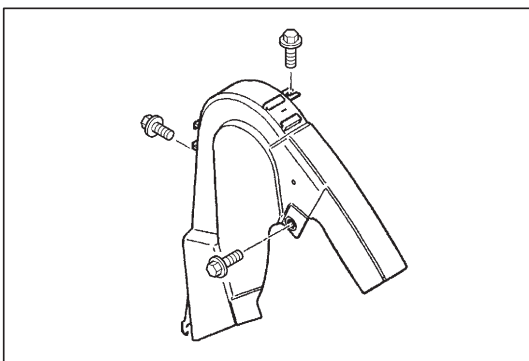

- 7) Install upper timing belt cover.

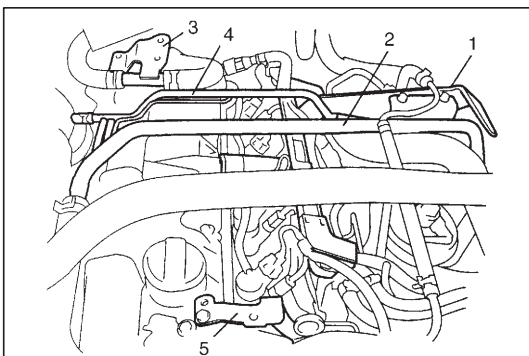

- 8) Install intercooler bracket (1), heater outlet pipe (2), heater inlet pipe (3), vacuum pipe (4) and bracket.
- 9) Install intercooler inlet hose and intercooler.
- 10) Install strut tower bar, TP sensor (Accelerator stroke sensor) and intake air pressure sensor.

CAUTION:

Before installing intake air pressure sensor hose, degrease connect part of hose and intercooler outlet hose. Otherwise hose may become detached and cause turbo system failure.

- 11) Connect negative cable at battery.

INTAKE MANIFOLD

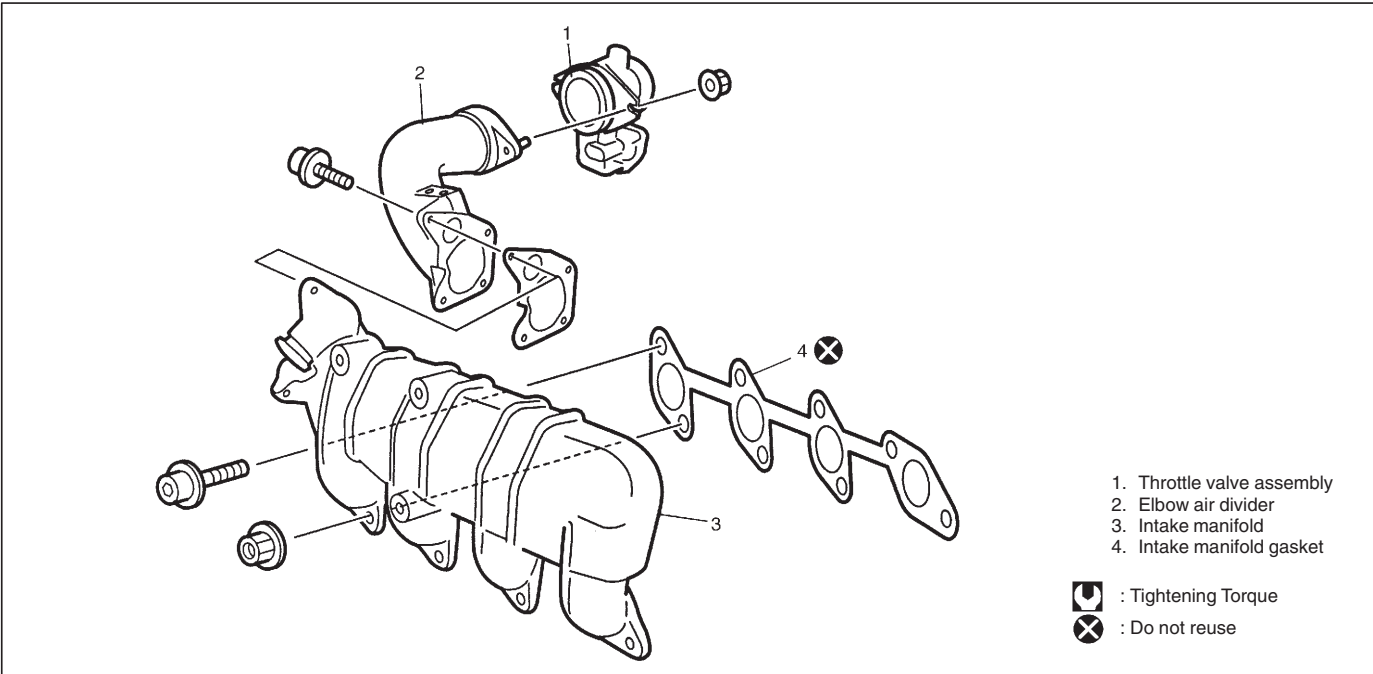

REMOVAL

- 1) Remove exhaust manifold with turbocharger referring to "TURBOCHARGER" in Section 6E3.
- 2) Remove throttle valve assembly referring to "THROTTLE VALVE ASSEMBLY" in Section 6E3.

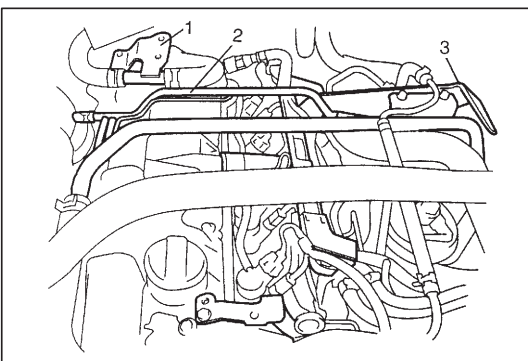

- 3) Remove heater inlet pipe (1), vacuum pipe (2) and intercooler bracket (3).

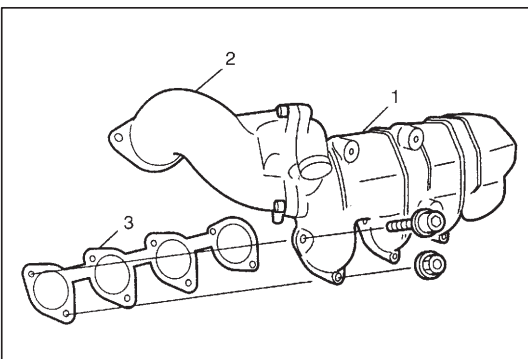

- 4) Remove intake manifold (1) with elbow air divider (2) from cylinder head and then its gasket (3).
- 5) Remove elbow air divider from intake manifold.

INSTALLATION

Reverse removal procedure for installation noting following points.

- Clean mating surfaces of intake manifold and cylinder head.
- Use new intake manifold gasket.
- Check to ensure that all removed parts are back in place. Reinstall any necessary parts which have not been reinstalled.
- Install exhaust manifold with turbocharger referring to “TURBOCHARGER” in Section 6E3.
- Install throttle valve assembly referring to “THROTTLE VALVE ASSEMBLY” in Section 6E3.

EXHAUST MANIFOLD**REMOVAL/INSTALLATION**

Refer to “TURBOCHARGER” in Section 6E3.

TIMING BELT AND BELT TENSIONER (ENGINE WITH CAMSHAFT HUB)

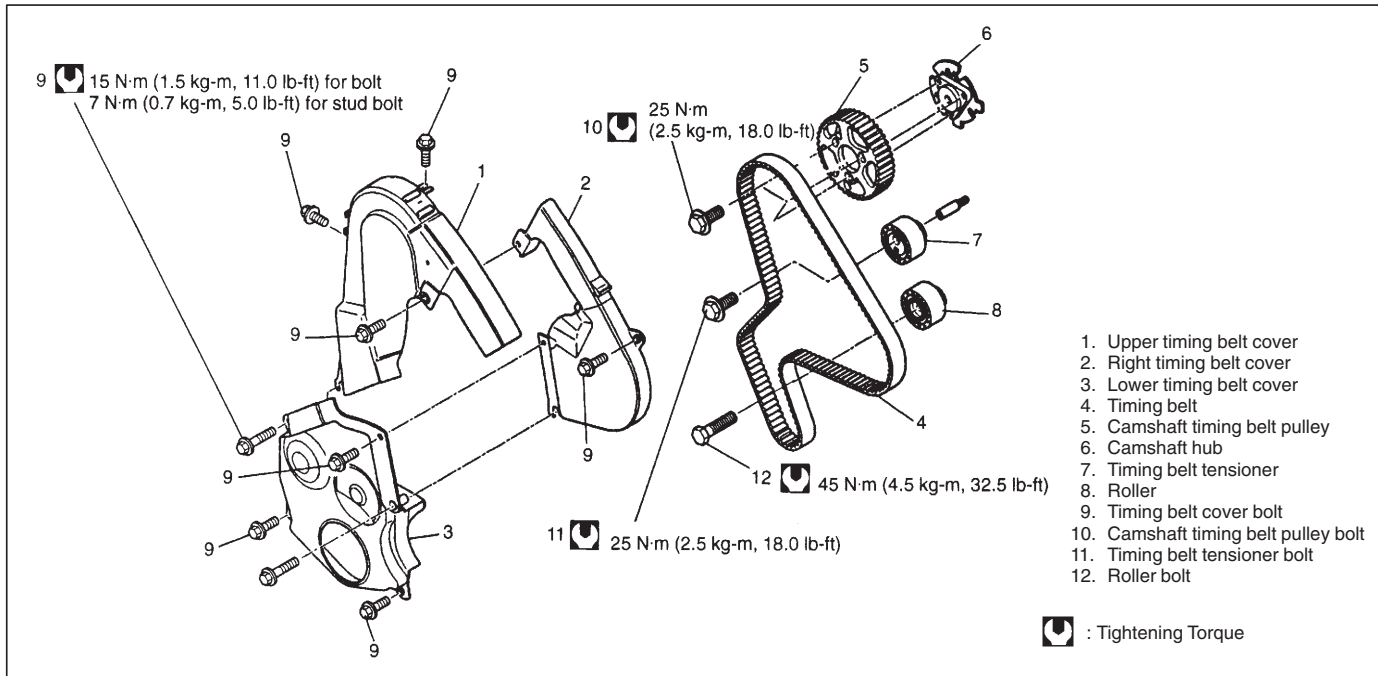

REMOVAL

- 1) Disconnect negative cable at battery.
- 2) Remove A/C compressor belt, if equipped.
- 3) Remove generator belt referring to "GENERATOR BELT" in Section 6H.
- 4) Remove radiator referring to "RADIATOR" in Section 6B.

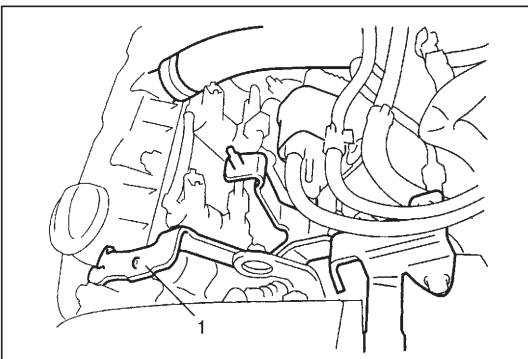

- 5) Remove bracket (1).

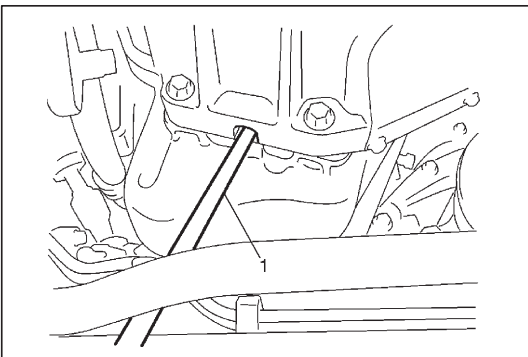

- 6) Remove crankshaft pulley bolt with crankshaft locked by using flat end rod (1) or the like as shown in figure.

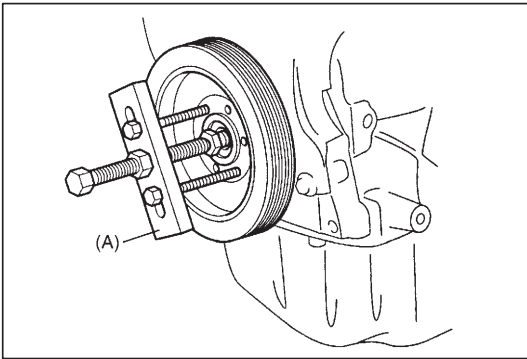

- 7) Remove crankshaft pulley.
If it is hard to remove, install crankshaft pulley bolt without washer and use special tools.

Special Tool
(A): 09944-36011

- 8) Remove timing belt covers.

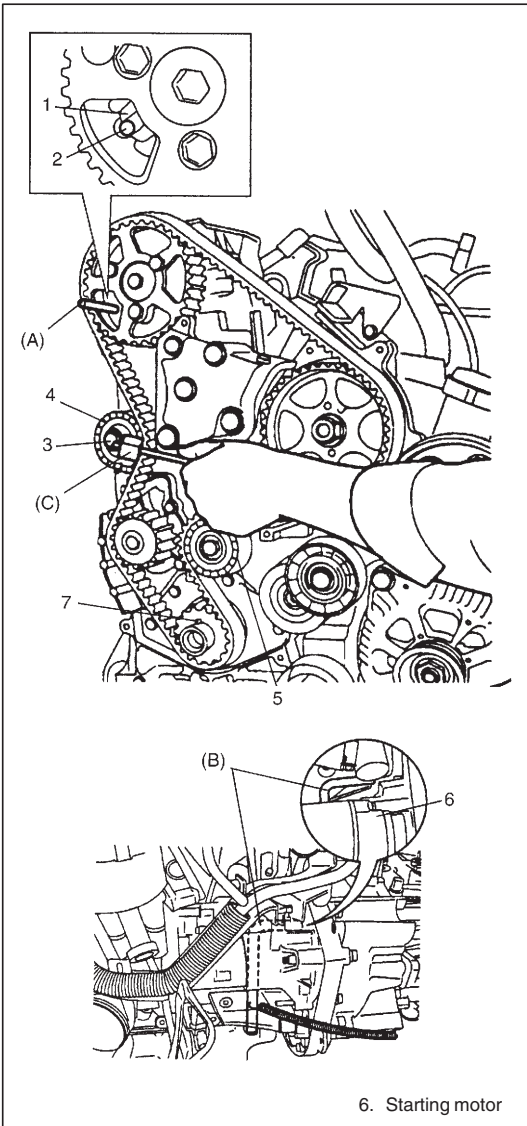

- 9) Remove fuel filter assembly.
10) Turn crankshaft so that crank timing pulley key (7) turns up, and then lock camshaft hub (1) inserting special tool (A) into cylinder head hole (2) as shown in figure.

Special Tool
(A): 09910-26540/OUT0000151

- 11) Lock flywheel (MT) or drive plate (AT) inserting special tool (B) into holes in both cylinder block and flywheel (MT) (or drive plate (AT)) with crank timing pulley key turned up.

Special Tool
(B): 09910-26530/OUT0000160

- 12) Loosen timing belt tensioner bolt (3). Then remove timing belt turning timing belt tensioner (4) clockwise with special tool (C).

Special Tool
(C): 09919-56550/OUT0000141

- 13) Remove timing belt tensioner and roller (5).

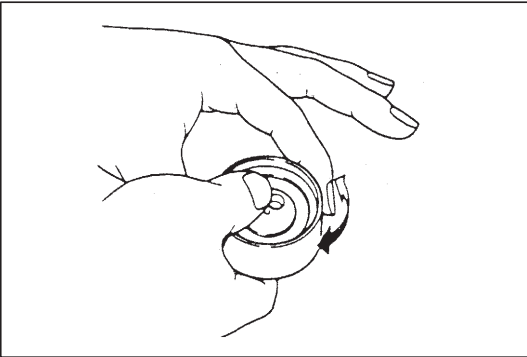
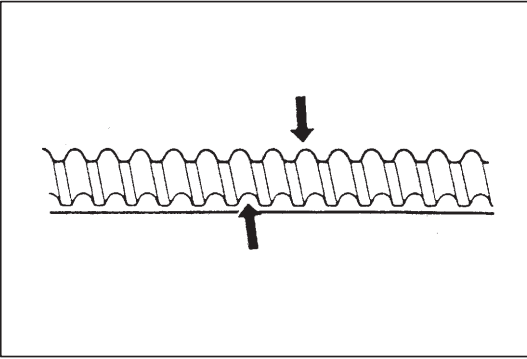

INSPECTION

- Inspect timing belt for wear or crack.
Replace it as necessary.
- Inspect timing belt tensioner and roller for smooth rotation.

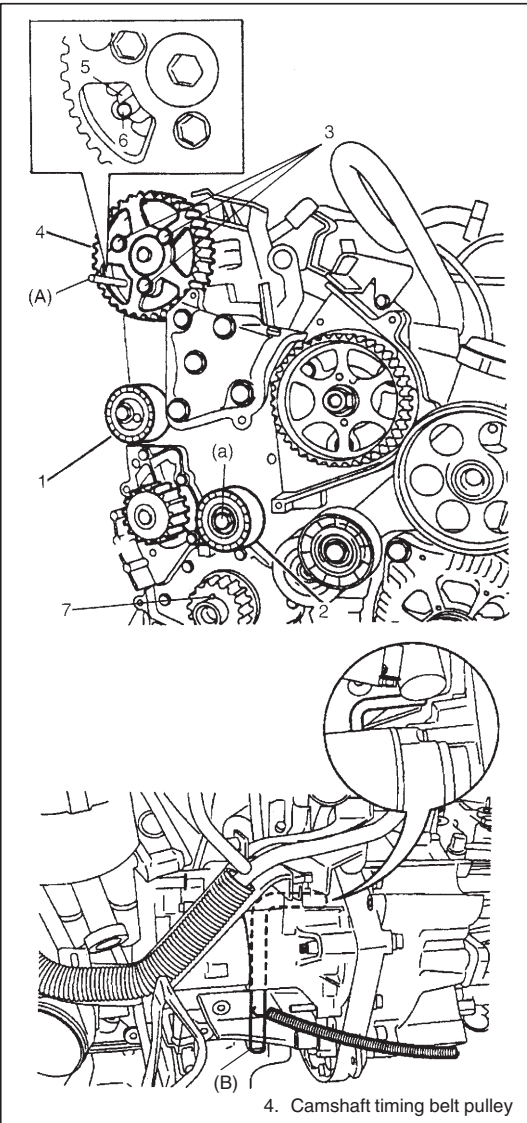

INSTALLATION

- 1) Install timing belt tensioner (1) and roller (2).
Do not tighten timing belt tensioner bolt with wrench yet. Tighten by hand only at this time.

Tightening Torque

Roller bolt (a): 45 N·m (4.5 kg-m, 32.5 lb-ft)

- 2) Check that camshaft hub (5) is locked inserting special tool (A) into cylinder head hole (6) as shown in figure.

Special Tool

(A): 09910-26540/OUT0000151

- 3) Check that flywheel (MT) or drive plate (AT) is locked inserting special tool (B) into holes in both cylinder block and flywheel (MT) (or drive plate (AT)) with crank timing pulley key (7) turned up.

Special Tool

(B): 09910-26530/OUT0000160

- 4) Loosen camshaft timing belt pulley bolts (3).

NOTE:

Do not remove camshaft timing belt pulley bolts (3).

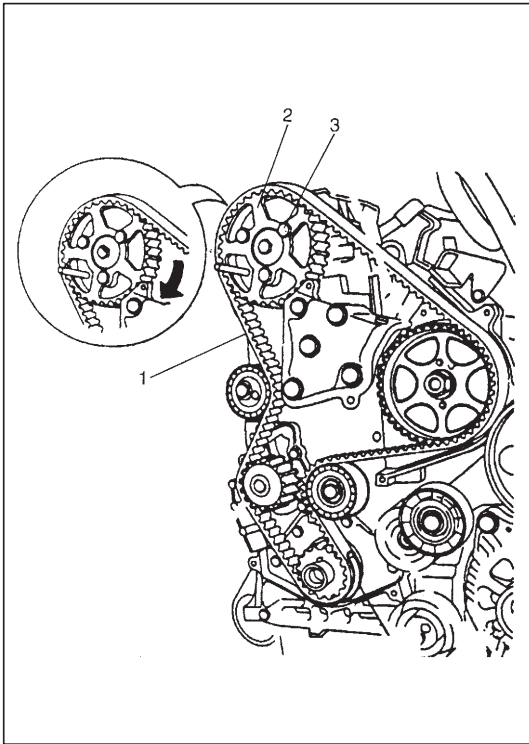

- 5) Install timing belt (1) with camshaft timing belt pulley (2) turned clockwise within oblong hole (3) of camshaft timing belt pulley as shown in figure.

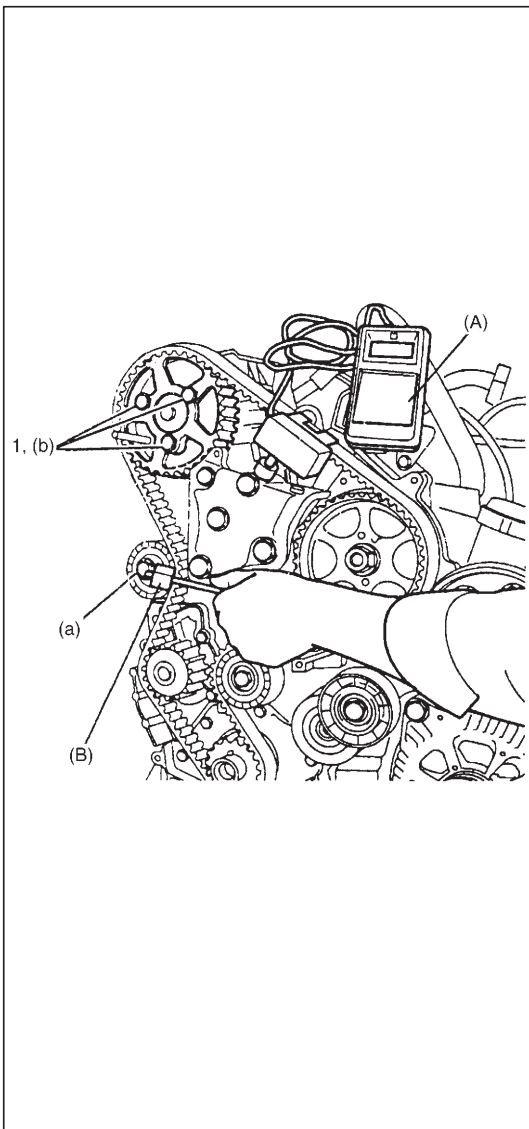

- 6) Fit special tool as shown in figure.

Special Tool

(A): 09919-56560/OUT0000138

- 7) Turn timing belt tensioner counterclockwise using special tool (B) until special tool (A) indicates 98 ± 2 . Then tighten timing belt tensioner bolt to specified torque.

Special Tool

(B): 09919-56550/OUT0000141

Tightening Torque

**Timing belt tensioner bolt (a):
25 N·m (2.5 kg·m, 18.0 lb·ft)**

- 8) By removing camshaft timing belt pulley bolt (1), check to make sure that bolt is not at the limit of bolt slot in pulley.
9) Install camshaft timing belt pulley bolts on camshaft timing belt pulley.
Tighten bolts to specified torque.

Tightening Torque

**Camshaft timing belt pulley bolt (b):
20 N·m (2.0 kg·m, 14.5 lb·ft)**

- 10) Remove all special tools and then turn crankshaft eight rotations clockwise.
11) Install special tool referring to step 10) of "TIMING BELT AND BELT TENSIONER REMOVAL".

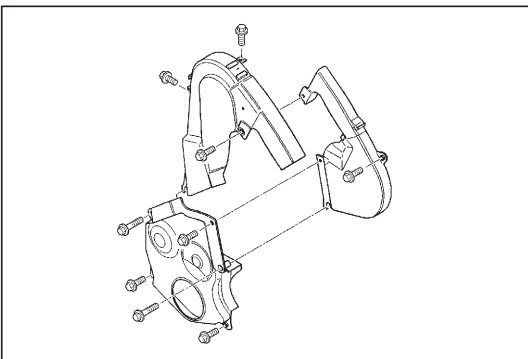
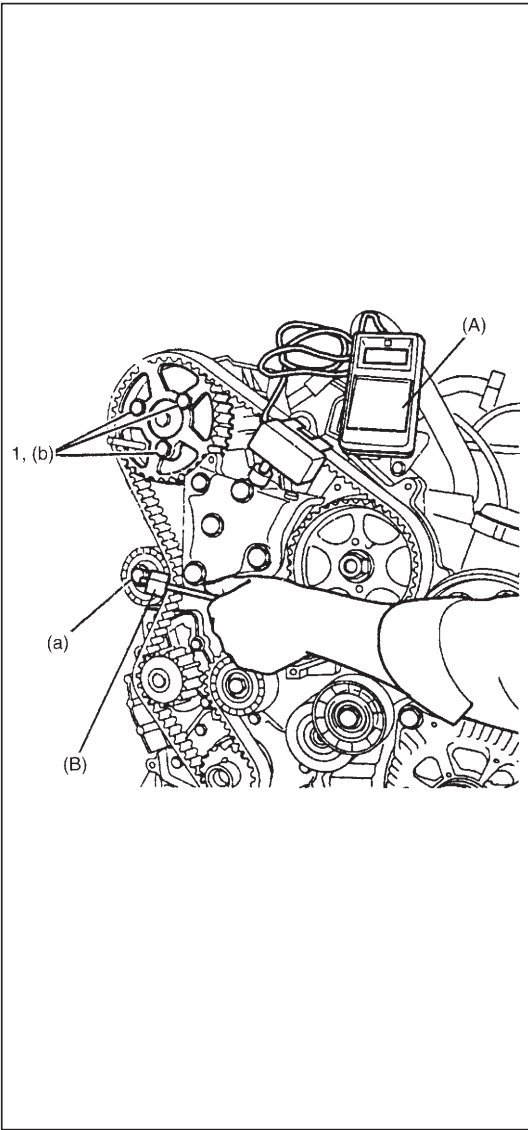

12) Loosen camshaft timing belt pulley bolts (1).

NOTE:

Do not remove camshaft timing belt pulley bolts (1).

13) Fit special tool as shown.

Special Tool

(A): 09919-56560/OUT0000138

14) Turn timing belt tensioner counterclockwise using special tool (B) until special tool (A) indicates 54 ± 2 . Then tighten timing belt tensioner bolt to specified torque.

Special Tool

(B): 09919-56550/OUT0000141

Tightening Torque

**Timing belt tensioner bolt (a):
25 N·m (2.5 kg-m, 18.0 lb-ft)**

15) Tighten camshaft timing belt pulley bolts to specified torque.

Tightening Torque

**Camshaft timing belt pulley bolt (b):
20 N·m (2.0 kg-m, 14.5 lb-ft)**

16) Remove special tool (A) and then install it again.

17) Check that special tool (A) indicates between 51 and 57. If indication of tool is out of specified value, perform step 4) to 14) again after loosening timing belt.

18) Remove special tools.

19) Install timing belt covers.

20) Install fuel filter assembly and connect fuel hoses securely.

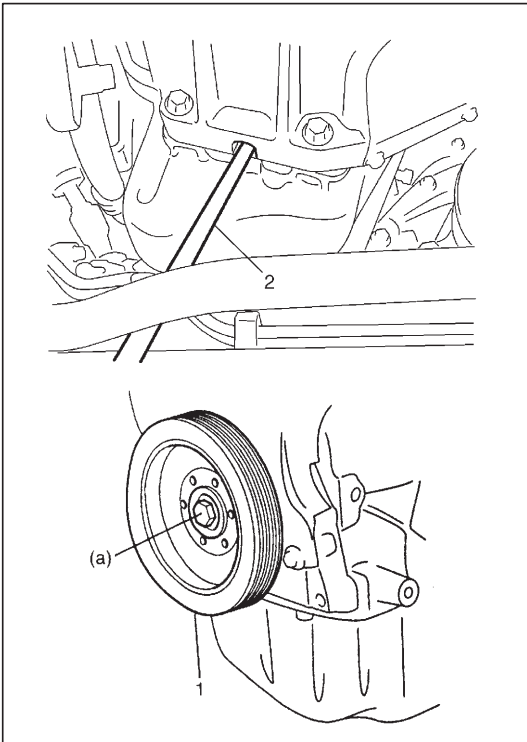

21) Install crankshaft pulley (1) with crankshaft locked by using flat end rod (2) or the like, apply sealant to crankshaft pulley bolt and tighten it gradually as follows.

- a) Tighten bolt to 40 N·m (4.0 kg-m, 29.0 lb-ft)
- b) Tighten bolt to 195 N·m (19.5 kg-m, 141 lb-ft) by turning it to about 50°.

Tightening Torque

Crankshaft pulley bolt (a): 195 N·m (19.5 kg-m, 141 lb-ft)

Sealant:

“A”: LOCTITE 273

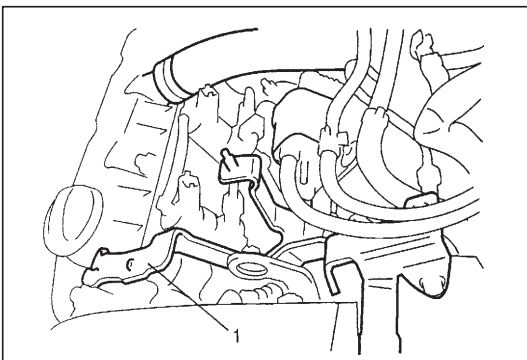

22) Install bracket (1).

23) Install radiator referring to “RADIATOR” in Section 6B.

24) Refill cooling system referring to Section 6B.

25) Install generator belt referring to “GENERATOR BELT” in Section 6H.

26) Connect negative cable to battery.

27) Check to make sure that there is no coolant leakage or fuel leakage at hose connection.

TIMING BELT AND BELT TENSIONER (ENGINE WITHOUT CAMSHAFT HUB)

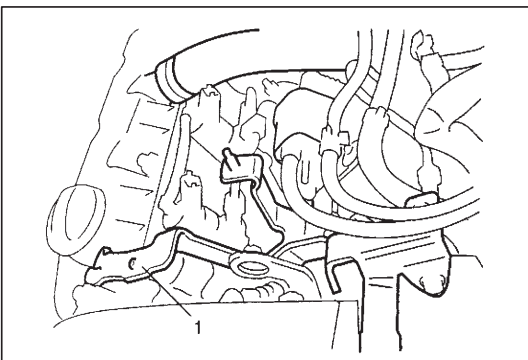
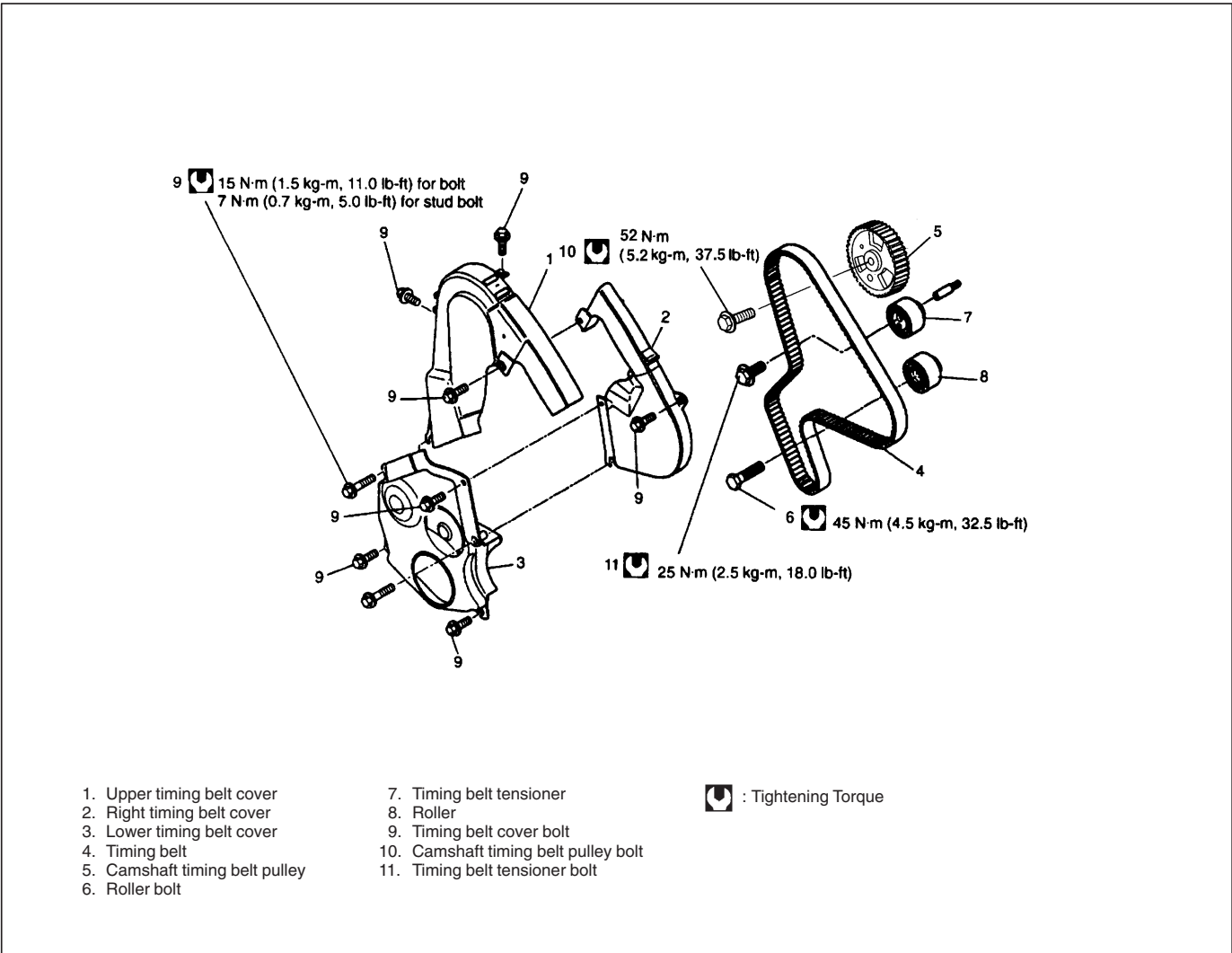

REMOVAL

- 1) Disconnect negative cable at battery.
- 2) Remove A/C compressor belt, if equipped.
- 3) Remove generator belt referring to "GENERATOR BELT" in Section 6H.
- 4) Remove radiator referring to "RADIATOR" in Section 6B.
- 5) Remove bracket (1).

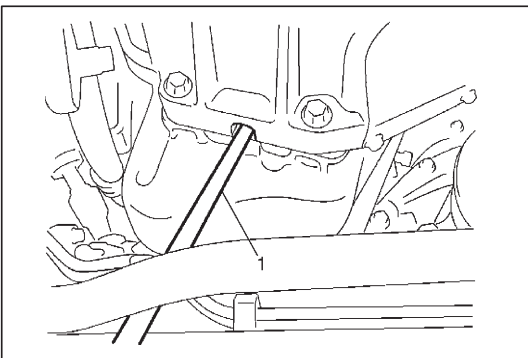

- 6) Remove crankshaft pulley bolt with crankshaft locked by using flat end rod (1) or the like as shown in figure.

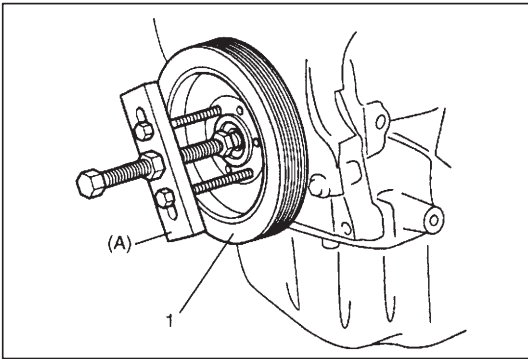

- 7) Remove crankshaft pulley (1).
If it is hard to remove, install crankshaft pulley bolt without washer and use special tools.

Special tool**(A): 09944-36011**

- 8) Remove timing belt covers.

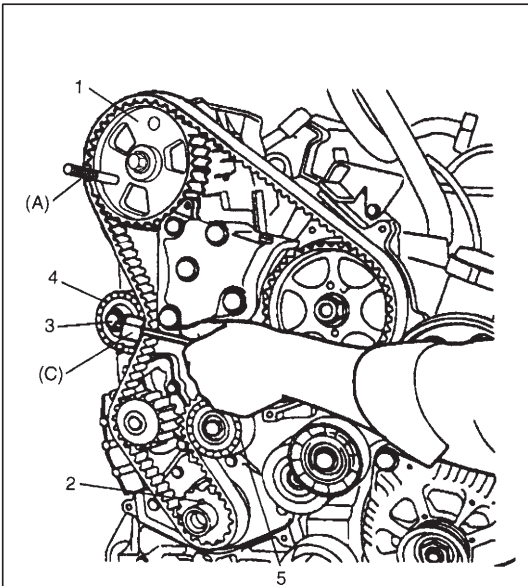

- 9) Turn crankshaft so that crank timing pulley key (2) turns up, and then lock camshaft timing belt pulley (1) inserting special tool (A) into cylinder head hole as shown in figure.

Special tool**(A): 09910-26540/OUT0000151**

- 10) Remove fuel filter assembly.

- 11) Lock flywheel (MT) or drive plate (AT) inserting special tool (B) into holes in both cylinder block and flywheel (MT) (or drive plate (AT)) with crank timing pulley key turned up.

Special tool**(B): 09910-26530/OUT0000160**

- 12) Loosen timing belt tensioner bolt (3). Then remove timing belt turning timing belt tensioner (4) clockwise with special tool (C).

Special tool**(C): 09919-56550/OUT0000141**

- 13) Remove timing belt tensioner (4) and roller (5).

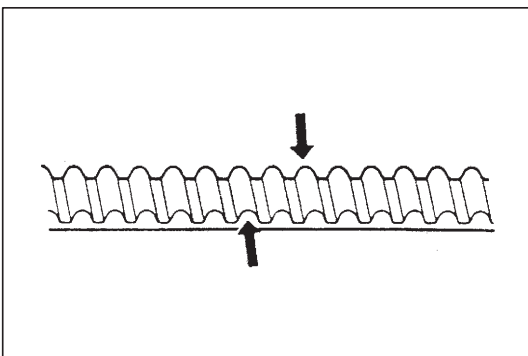
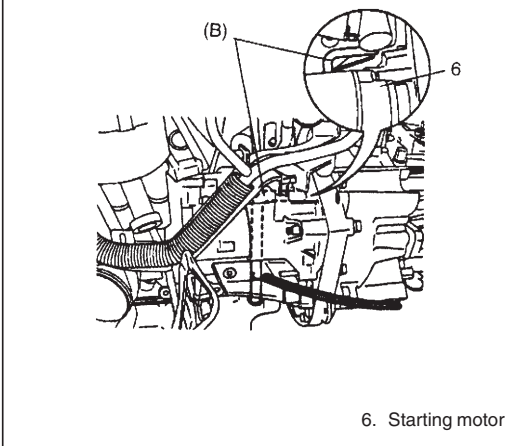
**INSPECTION**

- Inspect timing belt for wear or crack.
Replace it as necessary.

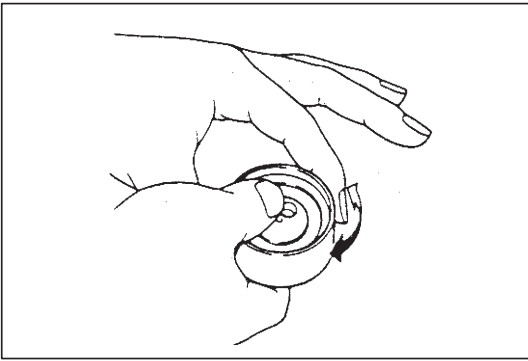

- Inspect timing belt tensioner and roller for smooth rotation.

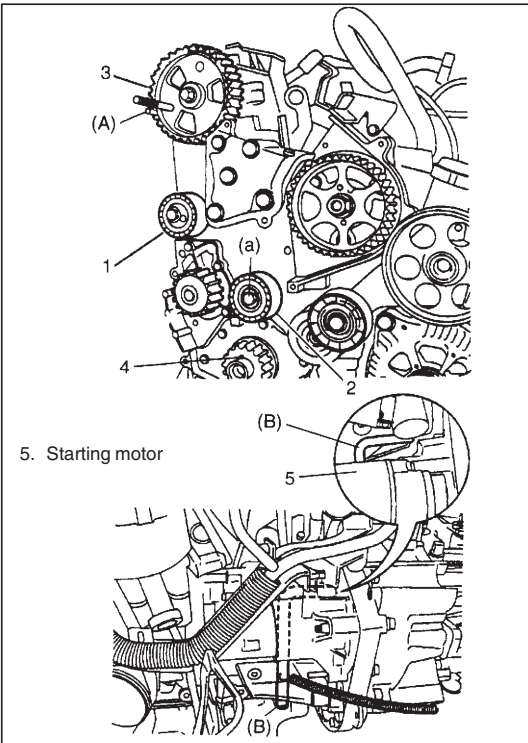

INSTALLATION

- 1) Check that camshaft timing belt pulley (3) is locked inserting special tool (A) into cylinder head hole as shown in figure.

Special tool

(A): 09910-26540/OUT0000151

- 2) Check that flywheel (MT) or drive plate (AT) is locked inserting special tool (B) into holes in both cylinder block and flywheel (MT) (or drive plate (AT)) with crank timing pulley key (4) turned up.

Special tool

(B): 09910-26530/OUT0000160

- 3) Install timing belt tensioner (1) and roller (2).
Do not tighten timing belt tensioner bolt with wrench yet.
Tighten by hand only at this time.

Tightening torque

Roller bolt (a): 45 N·m (4.5 kg-m, 32.5 lb-ft)

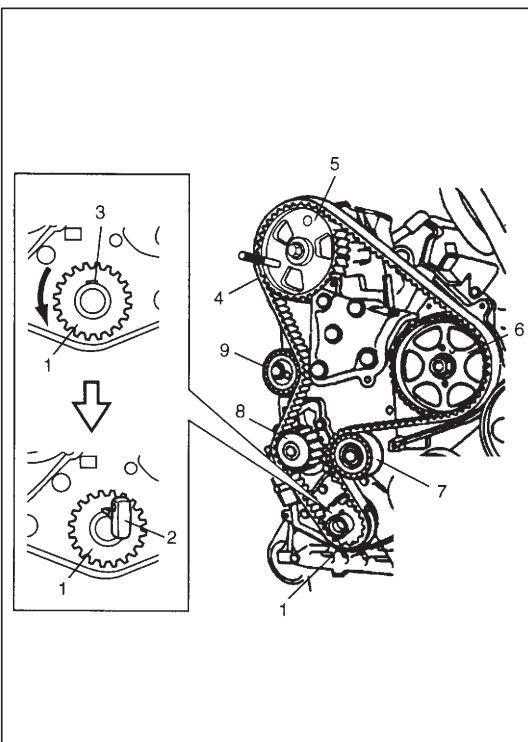

- 4) Turn crankshaft timing gear (1) to counterclockwise until groove end of crankshaft timing gear (1) attached to crankshaft timing gear key (3) end.
- 5) Insert a thickness gauge (2 mm (0.079 in.)) (2) or the like between crankshaft timing gear (1) and crankshaft timing gear key (3) as shown.
- 6) Install timing belt (4), fully taut, in the following order.
 - Camshaft timing belt pulley (5)
 - Injection pump pulley (6)
 - Roller (7)
 - Crankshaft timing gear (1)
 - Water pump drive gear (8)
 - Timing belt tensioner (9)

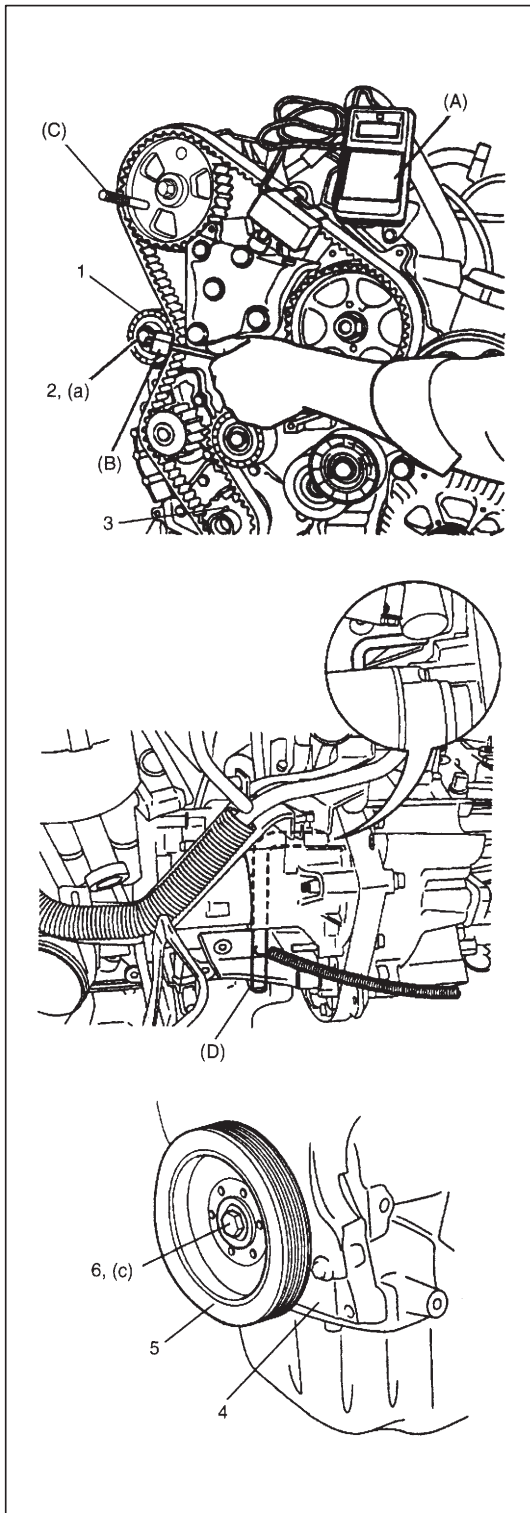

- 7) Remove thickness gauge (2) or the like from crankshaft timing gear (1).
- 8) Remove special tool (C) and (D).
- 9) Fit special tool (A) as shown in figure.

Special tool

(A): 09919-56560/OUT0000138

- 10) Turn timing belt tensioner (1) in counterclockwise using special tool (B) until special tool (A) indicates 98 ± 2 . Then tighten timing belt tensioner bolt (2) to specified torque.

Special tool

(B): 09919-56550/OUT0000141

Tightening torque

**Timing belt tensioner bolt (a):
20 N·m (2.0 kg·m, 14.5 lb-ft)**

- 11) Remove special tool (A).
- 12) Turn crankshaft so that crank timing pulley key (3) turns up, and then lock camshaft timing belt pulley (1) inserting special tool (C) into cylinder head hole as shown in figure.

Special tool

(C): 09910-26540/OUT0000151

- 13) Lock flywheel (MT) or drive plate (AT) inserting special tool (D) into holes in both cylinder block and flywheel (MT) (or drive plate (AT)) with crank timing pulley key turned up.

Special tool

(D): 09910-26530/OUT0000160

- 14) Install lower timing belt cover (4), and then Install crankshaft pulley (5) and tighten crankshaft pulley bolt (6) to specified torque.

Tightening torque

**Crankshaft pulley bolt (c):
45 N·m (4.5 kg·m, 32.5 lb-ft)**

- 15) Remove all special tools, and then turn crankshaft over eight rotations in clockwise.
- 16) Install the following special tools again referring to step 12) and 13).

Special tool

(C): 09910-26540/OUT0000151

(D): 09910-26530/OUT0000160

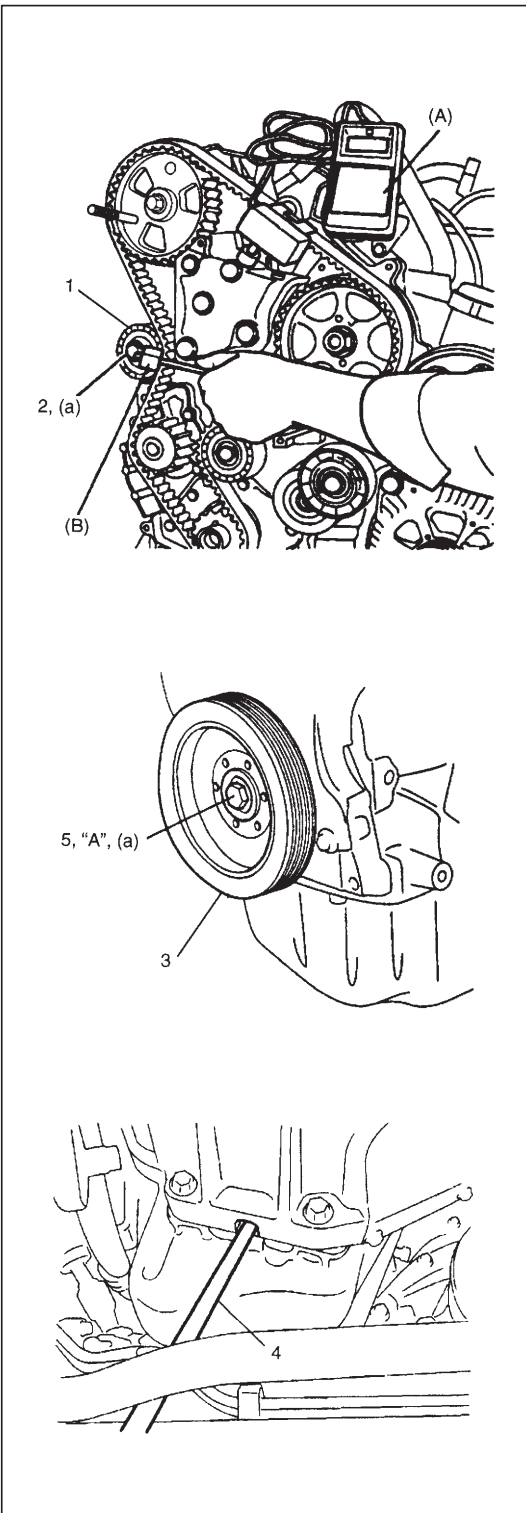

17) Loosen crankshaft pulley bolt.

NOTE:

Do not remove crankshaft pulley bolt.

18) Loosen timing belt tensioner bolt (2).

NOTE:

Do not remove timing belt tensioner bolt (2).

19) Fit special tool (A) as shown.

Special tool

(A): 09919-56560/OUT0000138

20) Turn timing belt tensioner (1) counterclockwise using special tool (B) until special tool (A) indicates 54 ± 2 . Then tighten timing belt tensioner bolt (2) to specified torque.

Special tool

(B): 09919-56550/OUT0000141

Tightening torque

Timing belt tensioner bolt (a): 20 N·m (2.0 kg·m, 14.5 lb-ft)

21) Remove crankshaft pulley bolt (5).

22) Install crankshaft pulley bolt (5) with crankshaft locked by using flat end rod (4) or the like, apply sealant to crankshaft pulley bolt (5) and tighten it gradually as follows.

a) Tighten crankshaft pulley bolt (5) to 40 N·m (4.0 kg·m, 29.0 lb-ft)

b) Tighten crankshaft pulley bolt (5) to 195 N·m (19.5 kg·m, 141 lb-ft) by turning it to about 50° .

Tightening torque

Crankshaft pulley bolt (b): 195 N·m (19.5 kg·m, 141 lb-ft)

Sealant:

"A": LOCTITE 273

23) Remove special tool (A) to release the internal forces.

24) Refit special tool (A) and check that special tool (A) indicates between 51 and 57.

If indication is out of specified value, perform step 1) to step 23) again after removing timing belt.

25) Remove all special tools.

26) Turn crankshaft 2 revolutions in clockwise.

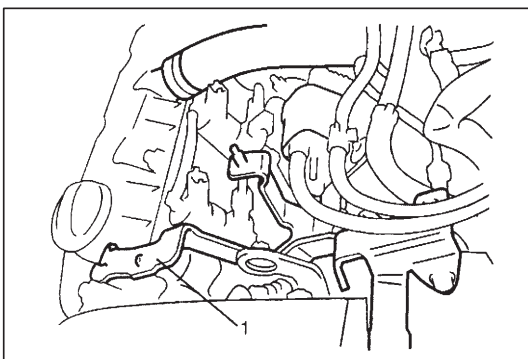
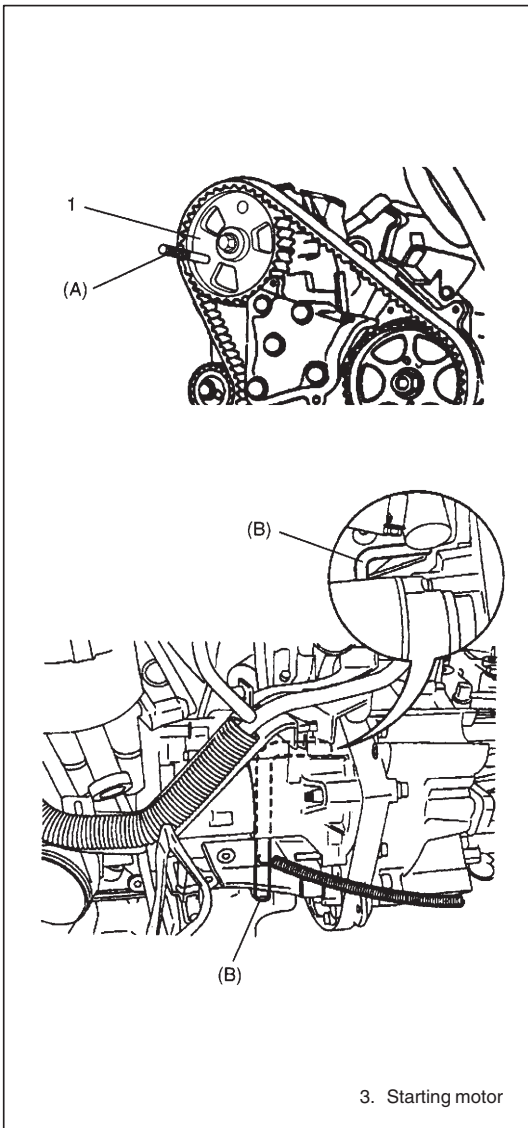

- 27) Check the following special tools installing procedures.
If special tool(s) can not install, perform step 1) to step 25) again after removing timing belt.

NOTE:

Camshaft and crankshaft have to be pegged by special tools when removing crankshaft pulley.

Otherwise, timing belt setting has to be reset.

- a) Camshaft timing belt pulley (1) is locked inserting special tool (A) into cylinder head hole as shown in figure.

Special tool

(A): 09910-26540/OUT0000151

- b) Flywheel (MT) or drive plate (AT) is locked inserting special tool (B) into holes in both cylinder block and flywheel (MT) (or drive plate (AT)).

Special tool

(B): 09910-26530/OUT0000160

- 28) Install upper timing belt covers.
29) Install fuel filter assembly and connect fuel hoses securely.

- 30) Install bracket (1).

- 31) Install radiator referring to "RADIATOR" in Section 6B.
32) Refill cooling system referring to Section 6B.
33) Install generator belt referring to "GENERATOR BELT" in Section 6H.
34) Connect negative cable to battery.
35) Check to make sure that there is no coolant leakage or fuel leakage at hose connection.

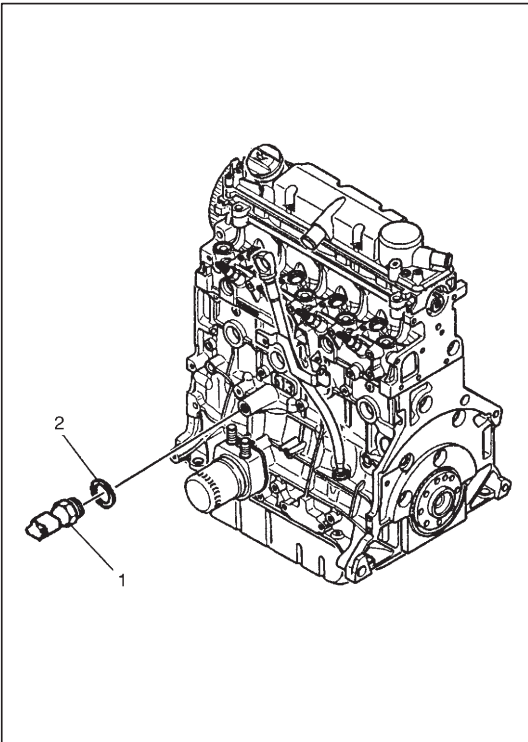

OIL PRESSURE SWITCH

REMOVAL

- 1) Detach degassing tank from its bracket.
- 2) Disconnect oil pressure switch connector.
- 3) Remove oil pressure switch (1).

INSTALLATION

- 1) Install oil pressure switch (1) with new gasket (2).
- 2) Tighten oil pressure switch.
- 3) Connect connector.
- 4) Install degassing tank to its bracket.
- 5) Start engine and check for oil leakage.

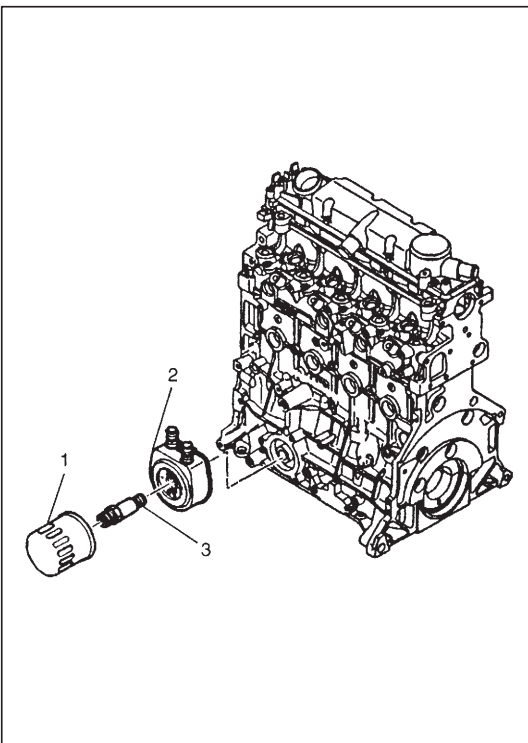

OIL COOLER

REMOVAL

- 1) Drain engine coolant.
- 2) Detach degassing tank from its bracket.
- 3) Remove oil filter (1).
- 4) Disconnect hoses and remove oil cooler (2).

INSTALLATION

- 1) Install oil cooler (2) with new gasket.
- 2) Tighten cooler stud stand (3).
- 3) Connect hoses and tighten oil filter (1).
- 4) Install degassing tank to its bracket.
- 5) Fill engine coolant.
- 6) Check engine oil level. Refer to section 0B.
- 7) Check for oil leakage.

OIL PAN AND OIL PUMP STRAINER

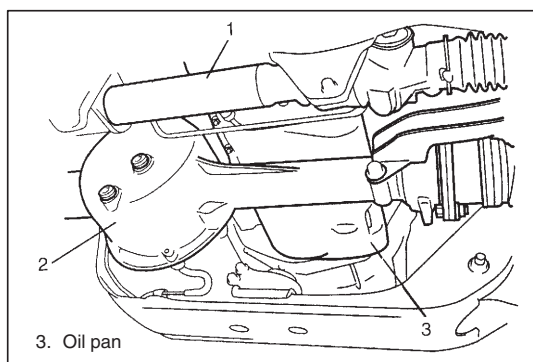
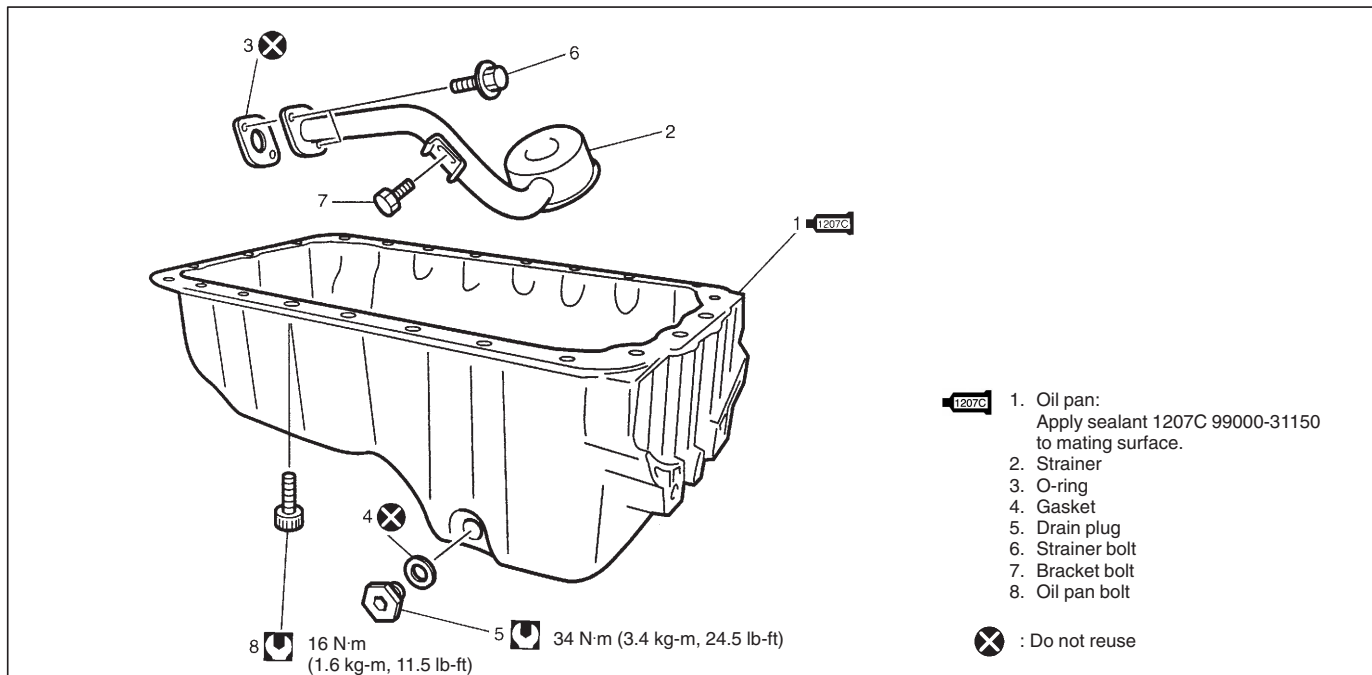

REMOVAL

- 1) Remove oil level gauge.
- 2) Raise vehicle and remove both front wheels.
- 3) Remove steering gear box (1) from vehicle referring to Section 3B1.
- 4) Remove front differential housing (2) with differential from chassis referring to Section 7E.

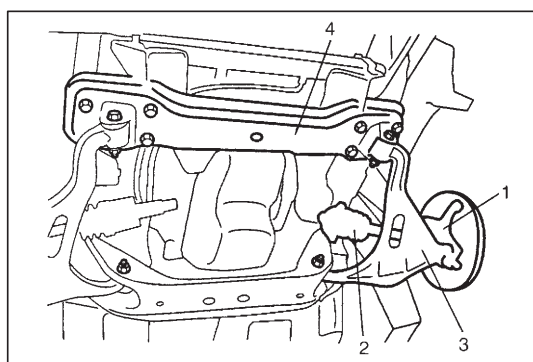

- 5) Remove knuckle (1), drive shaft (2) and suspension control arm (3) of either side after removing stabilizer bar. Refer to Section 3D of the Service Manual mentioned in FOREWORD of this manual.
- 6) Detach suspension frame (4) from chassis.

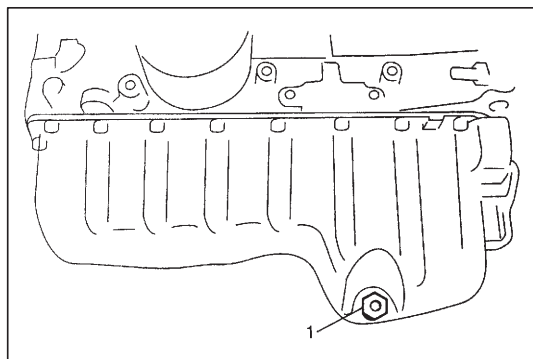

- 7) Drain engine oil by removing drain plug (1).

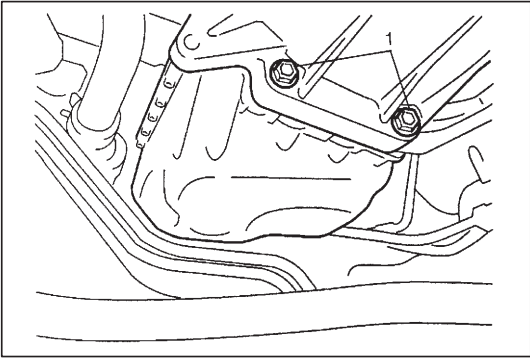

8) Remove transmission fastening bolts (1).

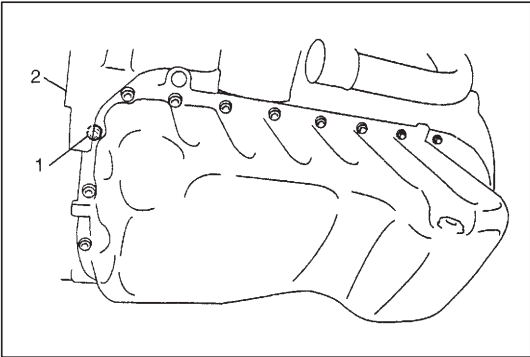

9) Remove oil pan bolts.

Bolt (1) at the rear of power steering pump bracket (2) should be loosened only. It is not possible to remove it due to interference with bracket.

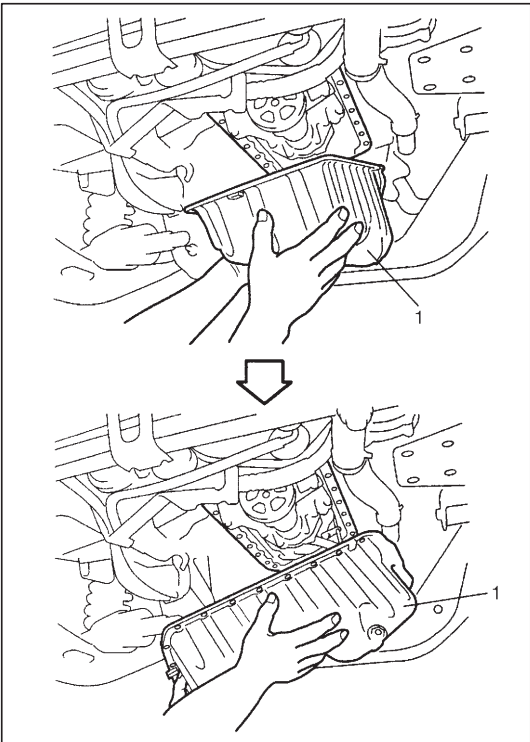

10) Remove oil pan (1) from cylinder block as shown.

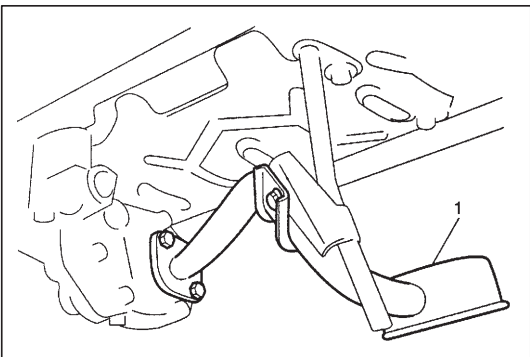

11) Remove oil pump strainer (1).

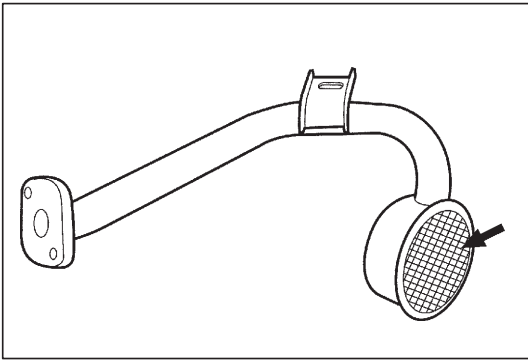

CLEANING

- Clean oil pump strainer screen.

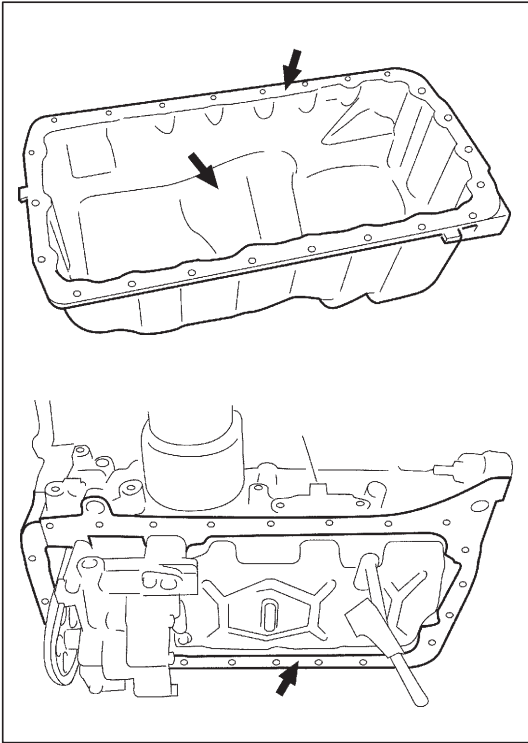

- Clean mating surfaces of oil pan and cylinder block. Remove oil, old sealant, and dust from mating surfaces and inside of oil pan.

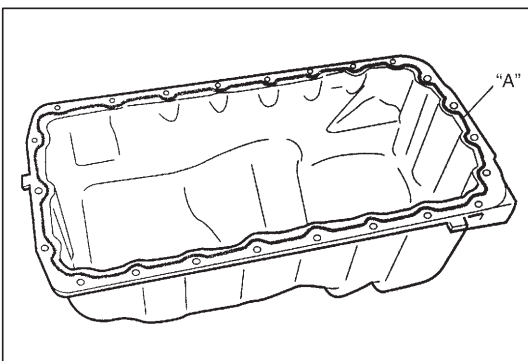

INSTALLATION

- 1) Apply sealant to oil pan mating surface continuously as shown in figure.

“A” Sealant: 99000-31150

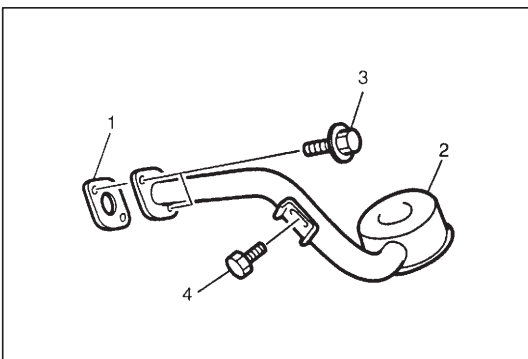

- 2) Using new gasket (1), install oil pump strainer (2) to oil pump. Tighten strainer bolt (3) first and then bracket bolt (4) to specified torque.

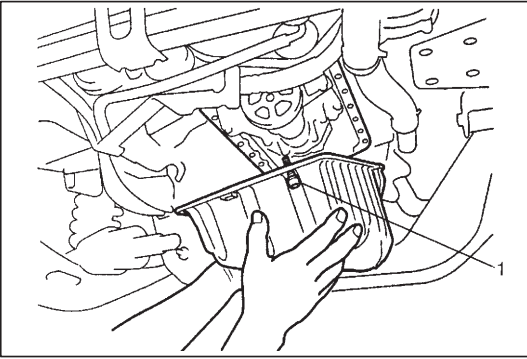

- 3) Fit oil pan to cylinder block using bolt (1) at the position as shown in figure.

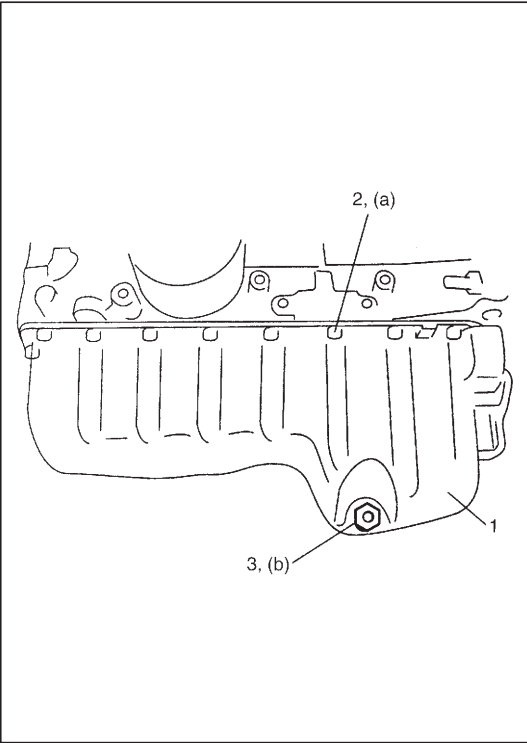

- 4) After fitting oil pan (1) to cylinder block, run in securing bolts (2) and start tightening at the center: move wrench outward, tightening one bolt at a time.
Tighten bolts to specified torque.

Tightening Torque

(a): 16 N·m (1.6 kg-m, 11.5 lb-ft)

- 5) Install new gasket and drain plug (3) to oil pan.
Tighten drain plug to specified torque.

Tightening Torque

(b): 34 N·m (3.4 kg-m, 24.5 lb-ft)

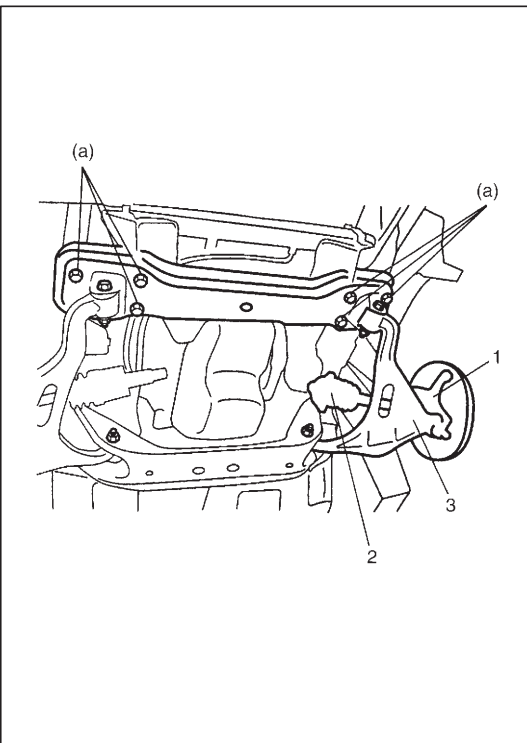

- 6) Install suspension frame to chassis.
Tighten bolts to specified torque.

Tightening Torque

(a): 85 N·m (8.5 kg-m, 61.5 lb-ft)

- 7) Install knuckle (1), drive shaft (2) and suspension control arm (3) referring to Section 3D.

- 8) Install front differential housing according to installation procedure described in Section 7E.
- 9) Refill front differential housing with gear oil, referring to Section 7E.
- 10) Install steering gear box to vehicle referring to Section 3B1.
- 11) Install oil level gauge.
- 12) Refill engine with engine oil, referring to item "ENGINE OIL CHANGE" in Section 0B.
- 13) Refill power steering system with specified fluid referring to Section 3B1.
- 14) Check to make sure that there is no engine oil leakage, differential oil leakage and power steering fluid leakage at each connection.

OIL PUMP

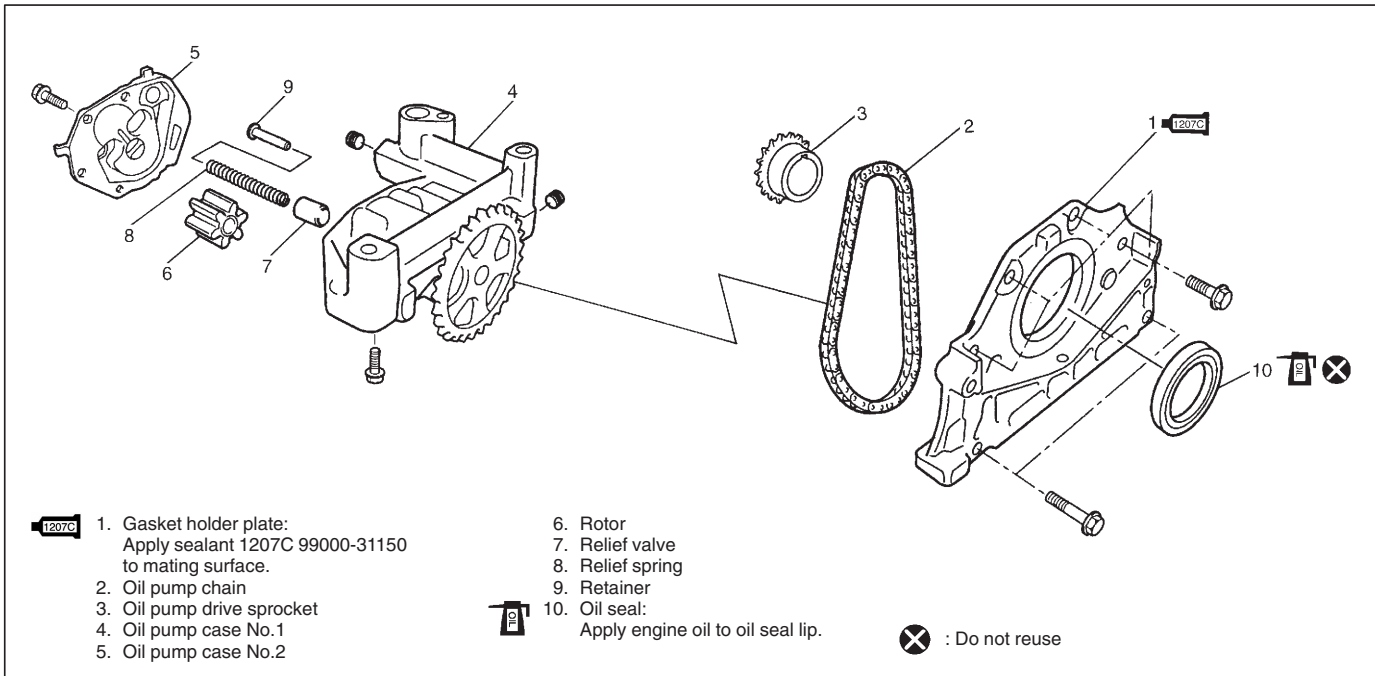

REMOVAL

- 1) Disconnect negative cable at battery.
- 2) Remove timing belt referring to "TIMING BELT AND BELT TENSIONER" in this section.
- 3) Remove oil pan and oil pump strainer referring to "OIL PAN AND OIL PUMP STRAINER" in this section.

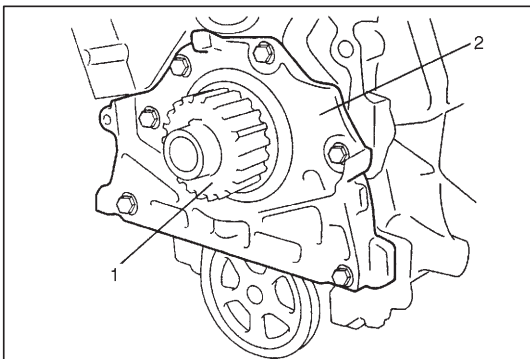

- 4) Remove crankshaft timing belt pulley (1) and then remove gasket holder plate (2).

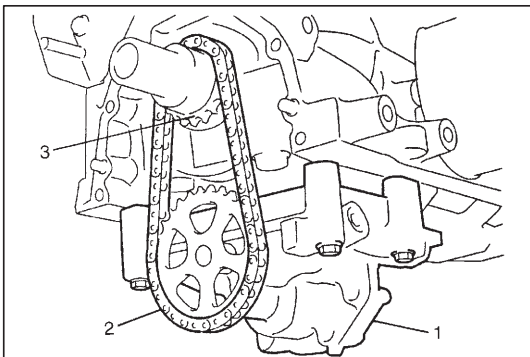

- 5) After removing sprocket key from crankshaft, remove oil pump (1), oil pump chain (2) and oil pump drive sprocket (3) all together.

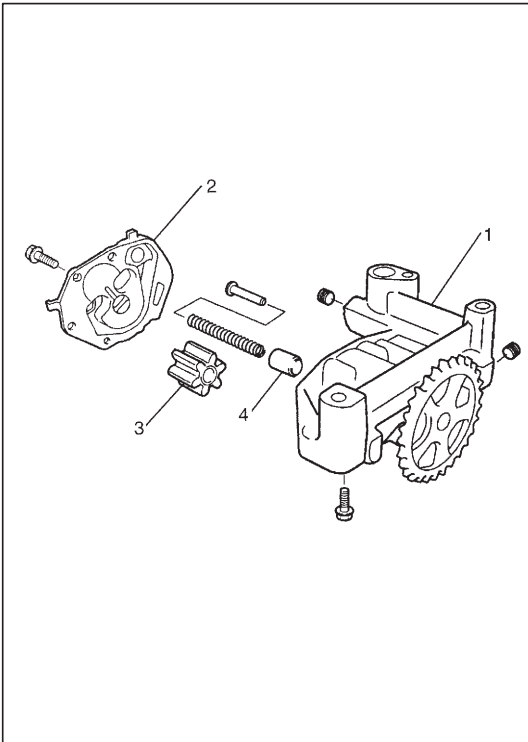

DISASSEMBLY

Disassemble oil pump as shown in figure.

CAUTION:

Do not remove oil pump sprocket.

Otherwise, oil pump sprocket and/or oil pump rotor shaft might be damaged.

INSPECTION

- Check rotor (3) and oil pump cases (1) (2) for excessive wear or damage.
- Check relief valve (4) for excessive wear or damage.

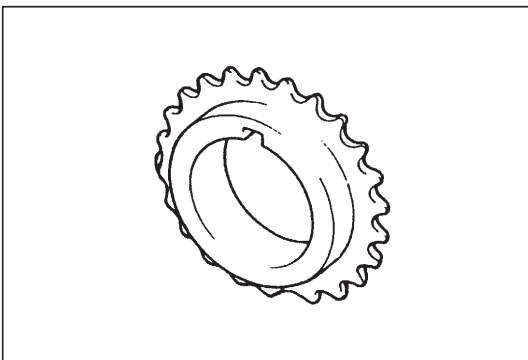

- Check teeth of oil pump drive sprocket for wear or damage.

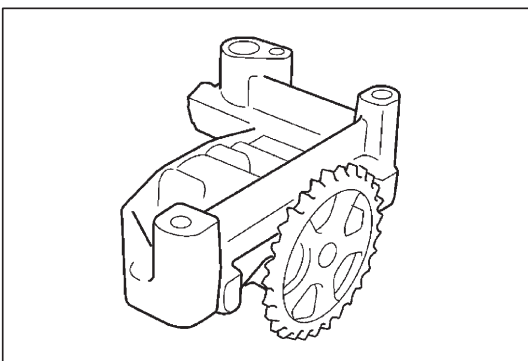

- Check teeth of oil pump sprocket for wear or damage.

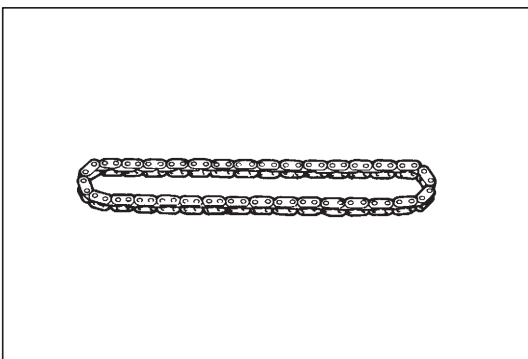

- Check oil pump chain for wear or damage.

ASSEMBLY

- 1) Wash, clean and then dry all disassembled parts.
- 2) Apply thin coat of engine oil to rotors and inside surface of each oil pump case.

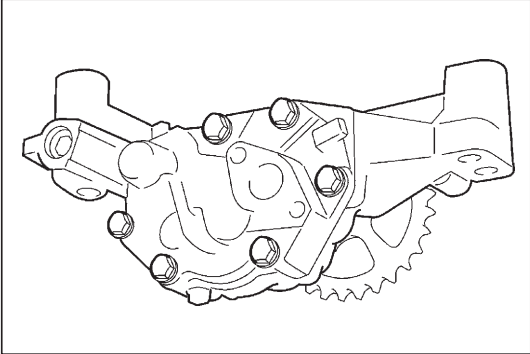

- 3) Assemble oil pump. After assembling oil pump, check to be sure that rotor turns smoothly by hand.

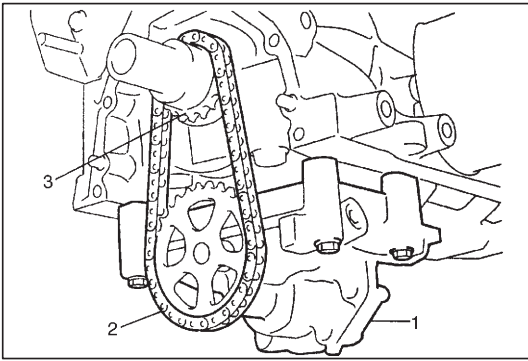

INSTALLATION

- 1) Install oil pump (1), oil pump chain (2) and oil pump drive sprocket (3) all together to cylinder block.
- 2) Install sprocket key.

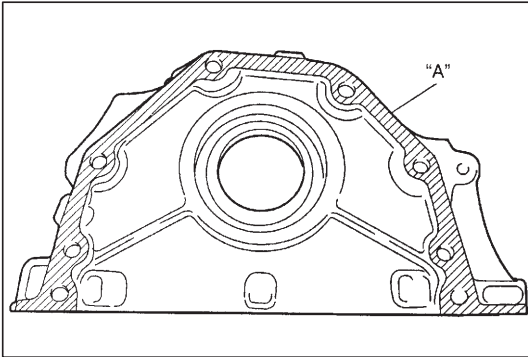

- 3) Apply sealant to mating surface of gasket holder plate.

“A” Sealant: 99000-31150

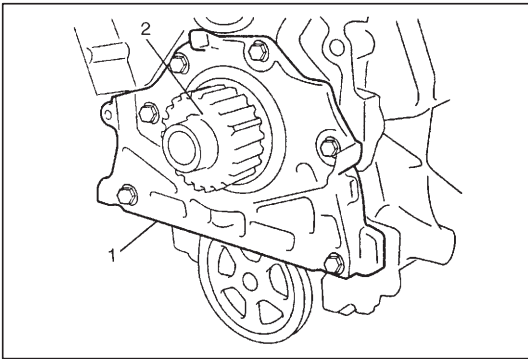

- 4) Install gasket holder plate (1) to cylinder block.
- 5) Install crankshaft timing belt pulley (2).

- 6) Install oil pump strainer and oil pan referring to “OIL PAN AND OIL PUMP STRAINER” in this section.
- 7) Install timing belt referring to “TIMING BELT AND BELT TENSIONER” in this section.
- 8) Connect negative cable at battery.

CAMSHAFT AND VALVE LASH ADJUSTERS

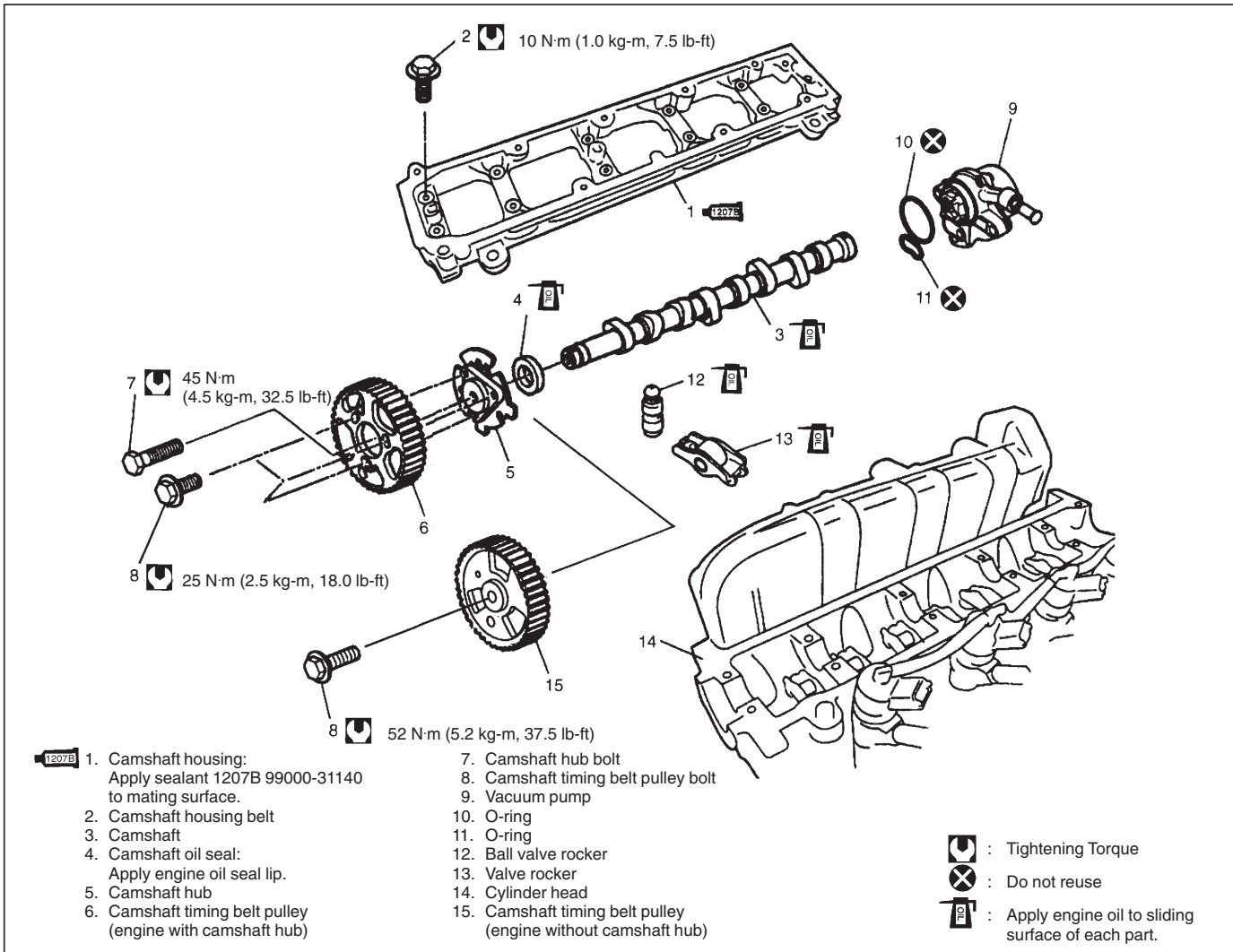

REMOVAL

- 1) Disconnect negative cable at battery.
- 2) Remove timing belt referring to "TIMING BELT AND BELT TENSIONER (ENGINE WITH CAMSHAFT HUB)" or "TIMING BELT AND BELT TENSIONER (ENGINE WITHOUT CAMSHAFT HUB)" in this section.
- 3) Remove cylinder head cover referring to "CYLINDER HEAD COVER" in this section.
- 4) Remove vacuum pump from cylinder head referring to "VACUUM PUMP" in Section 6E3.

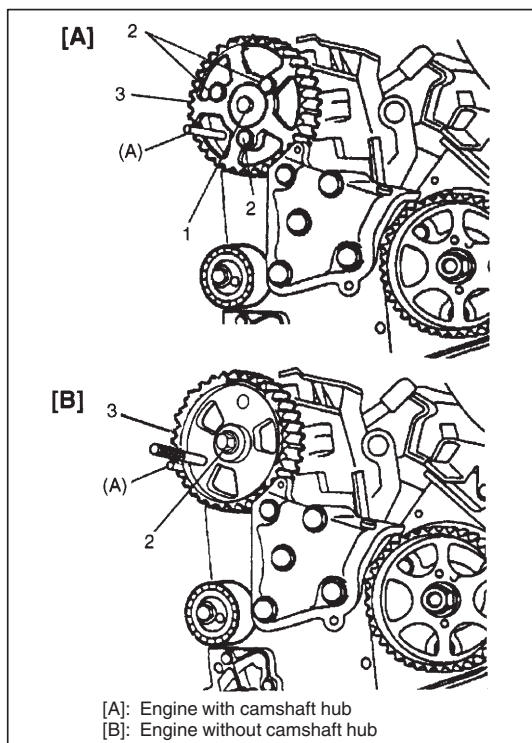

- 5) Remove camshaft timing belt pulley bolt(s) (2) or camshaft hub bolts (1) (if equipped) by using special tool.

Special Tool

(A): 09910-26540/OUT0000151

- 6) Remove camshaft timing belt pulley (3) and camshaft hub (if equipped).

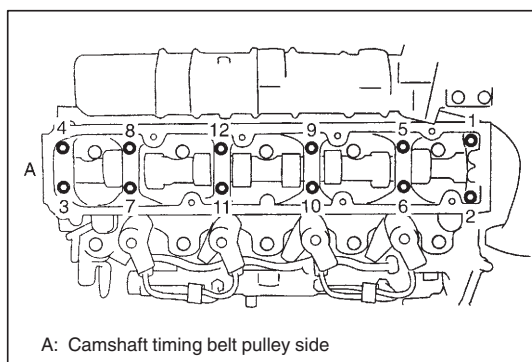

- 7) Loosen camshaft housing bolts in such order as indicated in figure and remove them.
8) Remove camshaft housing.
9) Remove camshaft and camshaft oil seal.

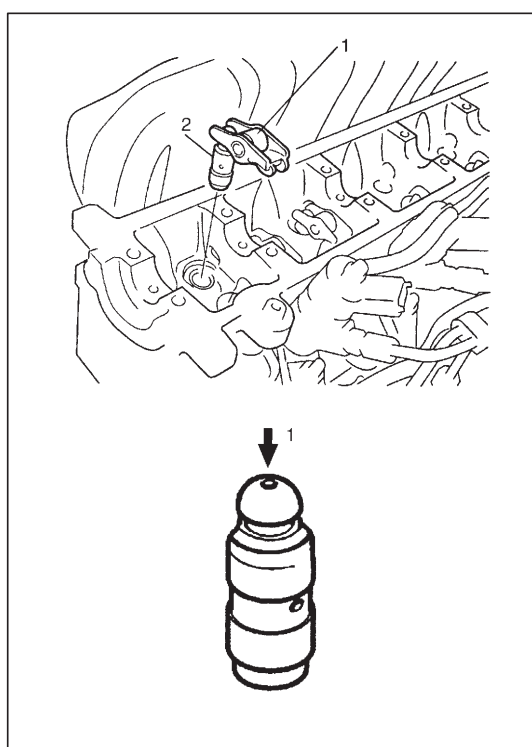

- 10) Remove valve rocker (1) with ball valve rocker (2).

NOTE:

- Never disassemble ball valve rocker.
- Don't apply force (1) to body of ball valve rocker, for oil in high pressure chamber in it will leak.
- Immerse removed ball valve rocker in clean engine oil and keep it there till reinstalling it so as to prevent oil leakage. If it is left in air, place it with its bucket body facing down. Don't place on its side or with bucket body facing up.

VALVES AND CYLINDER HEAD

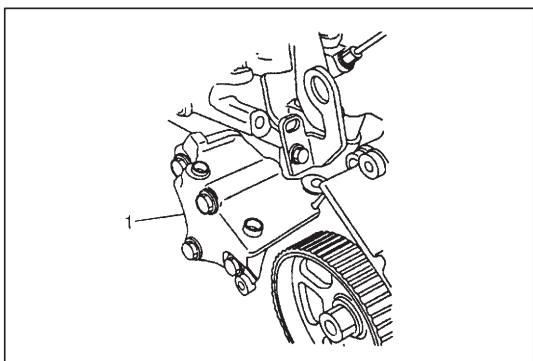
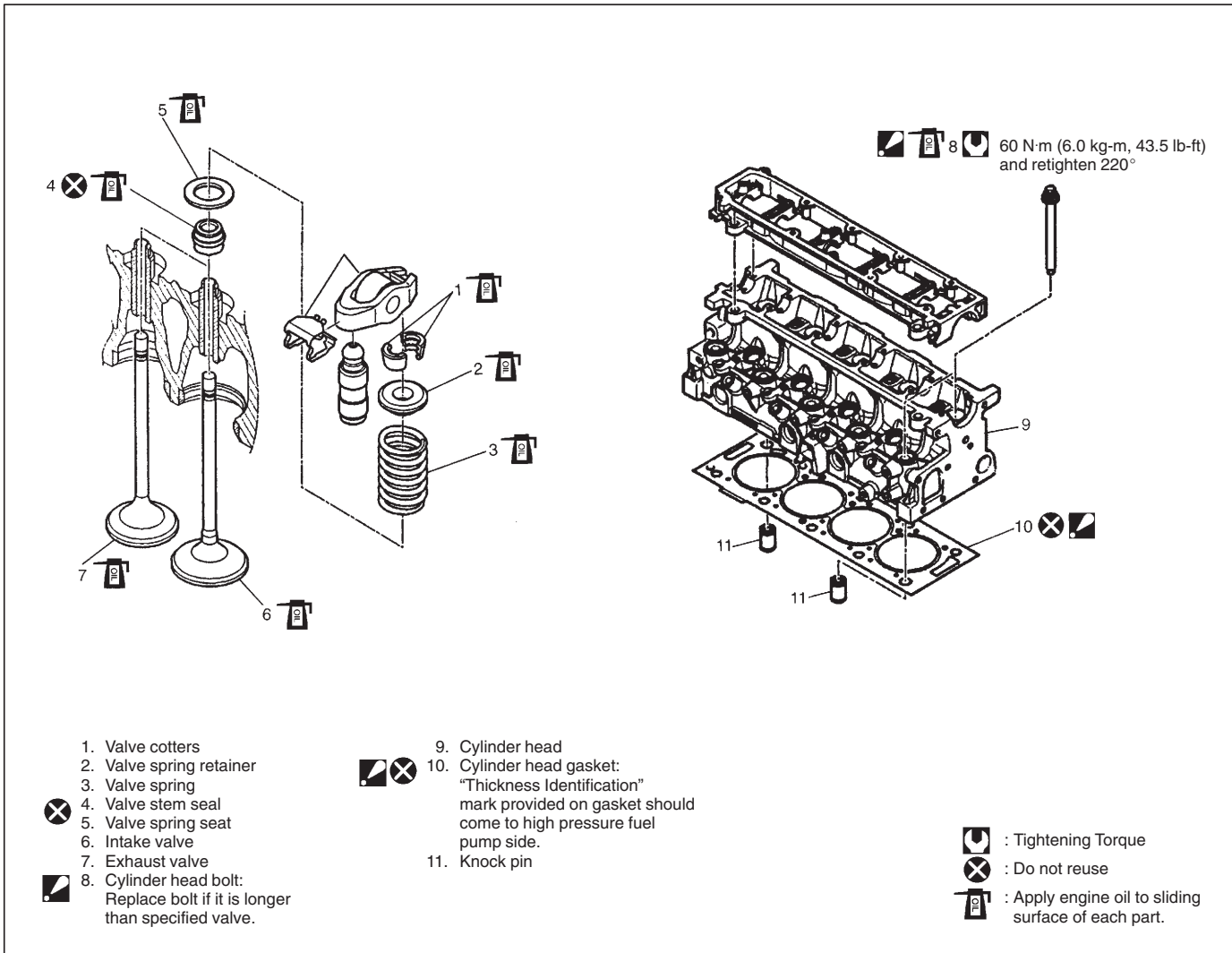

REMOVAL

- 1) Disconnect negative cable at battery.
- 2) Remove timing belt referring to "TIMING BELT AND BELT TENSIONER" in this section.
- 3) Remove engine bracket (1) from cylinder head and cylinder block.

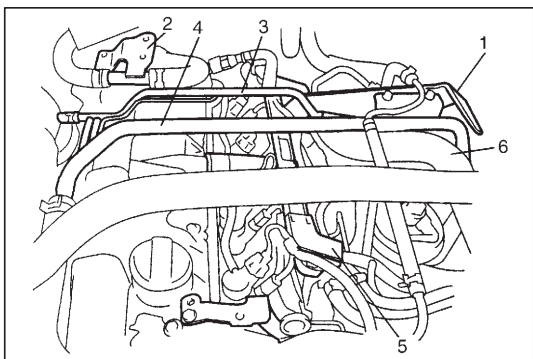

- 4) Remove intercooler bracket (1), radiator inlet hose (6), heater inlet pipe (2), vacuum pipe (3) and heater outlet pipe (4) with hoses.
- 5) Disconnect each connector and detach wire harness protector (5).

- 6) Remove intercooler air hoses.
- 7) Remove cylinder head cover referring to "CYLINDER HEAD COVER" in this section.
- 8) Disconnect vacuum hoses from throttle valve assembly, EGR valve and waste gate actuator.

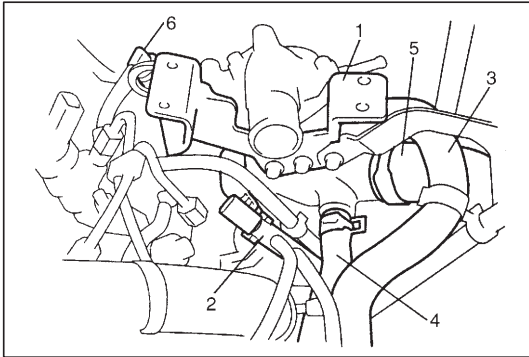

- 9) Remove bracket (1) from water outlet box.
- 10) Remove fuel temperature sensor (2).
- 11) Disconnect oil cooler inlet water hose (3), oil cooler outlet water hose (4), radiator outlet hose No.1 (5) and inlet fuel hoses (6) from water outlet box.
- 12) Remove oil level gauge upper guide bolt.
- 13) Disconnect fuel pressure sensor connector, ECT sensor connector and glow plug supply wire at the connector.

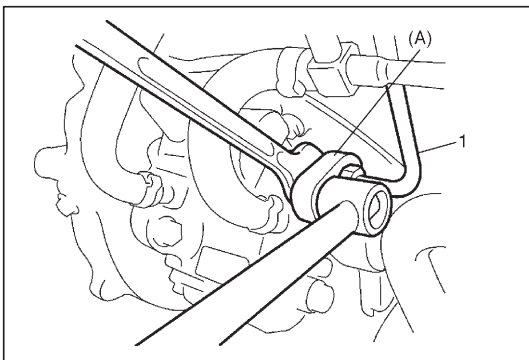

- 14) Remove high pressure supply pipe (1).
When loosening union nut of high pressure supply pipe, hold union nut of injection pump with wrench.

Special Tool

(A): 09950-76510/OUT0000148

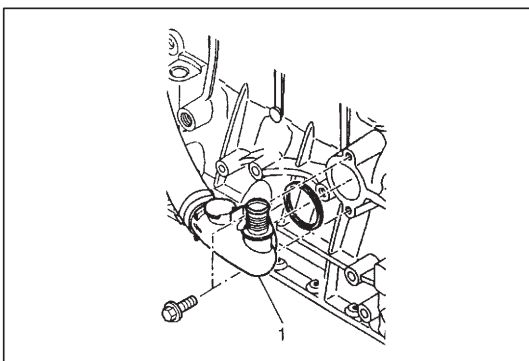

- 15) Detach water inlet box (1) from cylinder block.

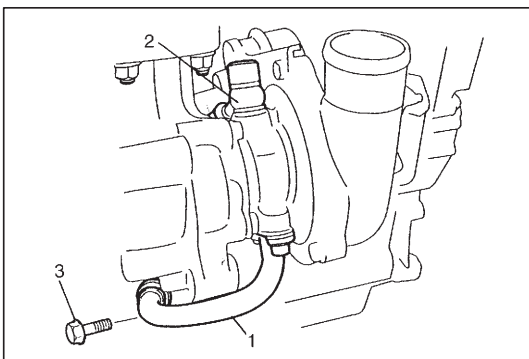

- 16) Disconnect oil return pipe (1) and lubrication pipe (2) from turbocharger.
- 17) Remove turbocharger bracket bolt (3).

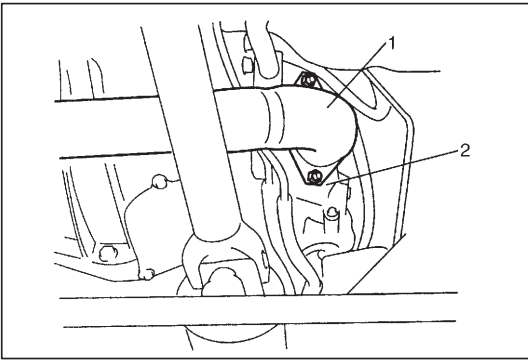

18) Disconnect exhaust No.1 pipe (1) from turbocharger outlet pipe (2).

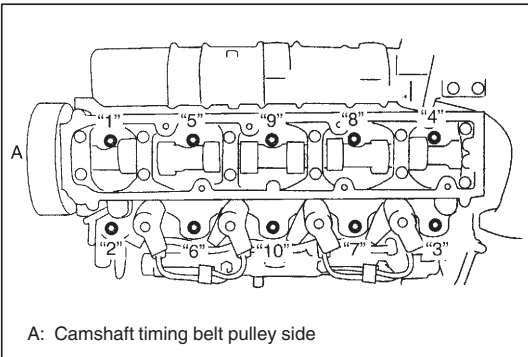

19) Loosen cylinder head bolts in such order as indicated in figure and remove them.

20) Check all around cylinder head for any other parts required to be removed or disconnected and remove or disconnect whatever necessary.

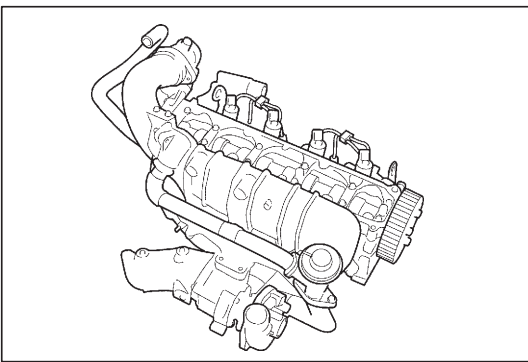

21) Remove cylinder head with intake manifold, exhaust manifold, turbocharger, water outlet box, injectors and common rail using lifting device.

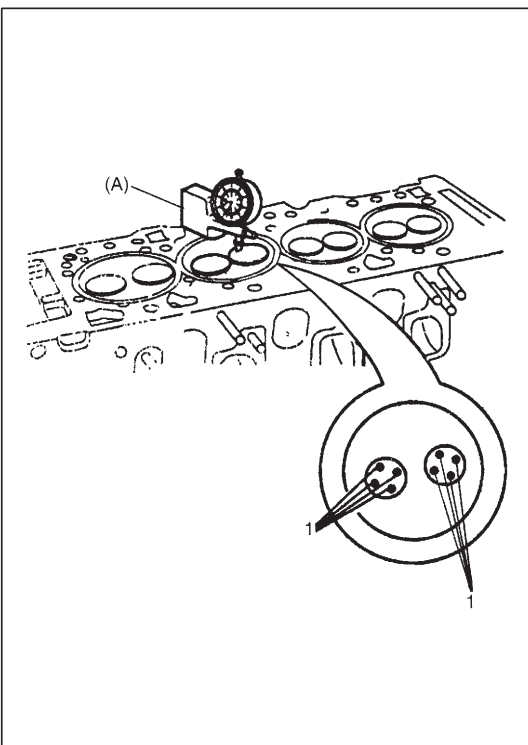

DISASSEMBLY

- 1) For ease in servicing cylinder head, remove intake manifold, exhaust manifold with turbocharger, water outlet box, injectors, common rail and glow plugs.
- 2) Remove camshaft and valve rockers referring to "CAMSHAFT AND VALVE ROCKERS" in this section.
- 3) Clean valve face and then measure protrusion at 4 points (1) of each valve using special tool as shown in figure.

Special Tool

(A): 09910-26510/OUT0000005

Average of values measured at 4 points	In	Max. 0.2 mm (0.008 in.)
	Ex	

If average is out of specification, grind valve seat and then lap valve on seat.

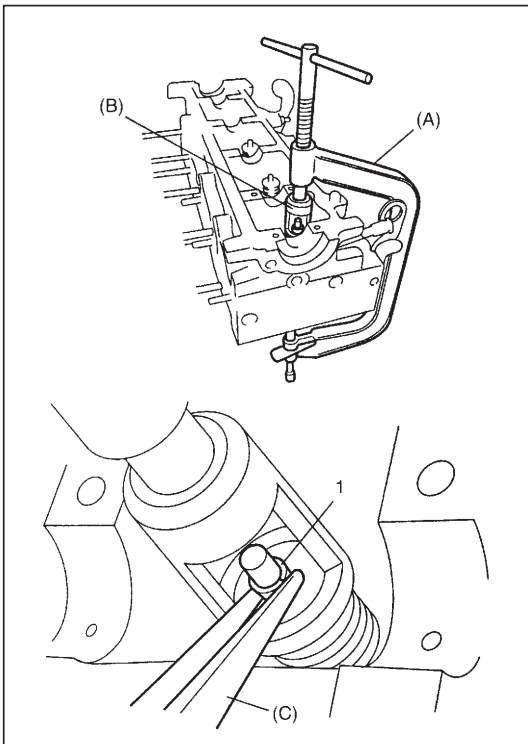

- 4) Using special tool (Valve lifter), compress valve springs and then remove valve cotters (1) by using special tool (Forceps) as shown.

Special Tool

(A): 09916-14510

(B): 09916-14910

(C): 09916-84511

- 5) Release special tool, and remove spring retainer and valve spring.
- 6) Remove valve from combustion chamber side.

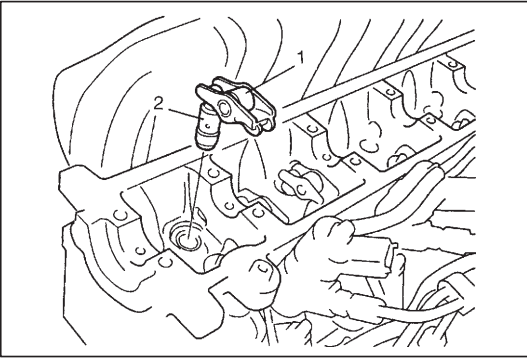

INSTALLATION

- 1) Install valve rocker (1) with ball valve rocker (2) to cylinder head. Apply engine oil around valve rocker and ball valve rocker and then install them to cylinder head.

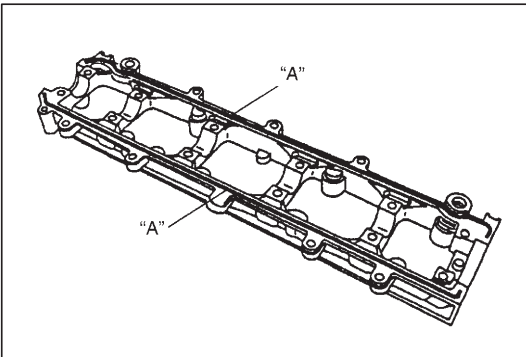

- 2) Apply sealant to mating surfaces of camshaft housing.

"A" Sealant: 99000-31140

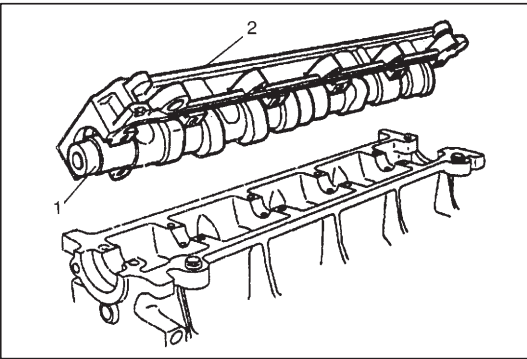

- 3) Apply engine oil to cams and journals on camshaft (1) and set camshaft to camshaft housing (2). Fit camshaft housing with camshaft to cylinder head.

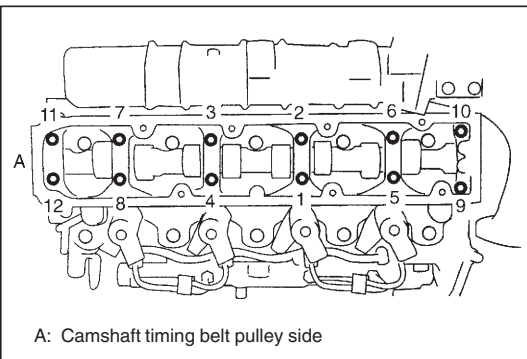

- 4) After applying oil to housing bolts, tighten them temporarily first. Then tighten them by following sequence as indicated in figure. Tighten a little at a time and evenly among bolts and repeat tightening sequence two or three times before they are tightened to specified torque.

Tightening Torque

10 N·m (1.0 kg-m, 7.5 lb-ft)

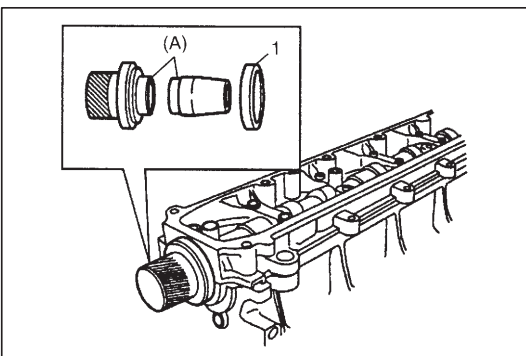

- 5) After applying grease to oil seal lip, fit camshaft oil seal (1) by using special tool.

Special Tool

(A): 09913-56510/OUT0000152

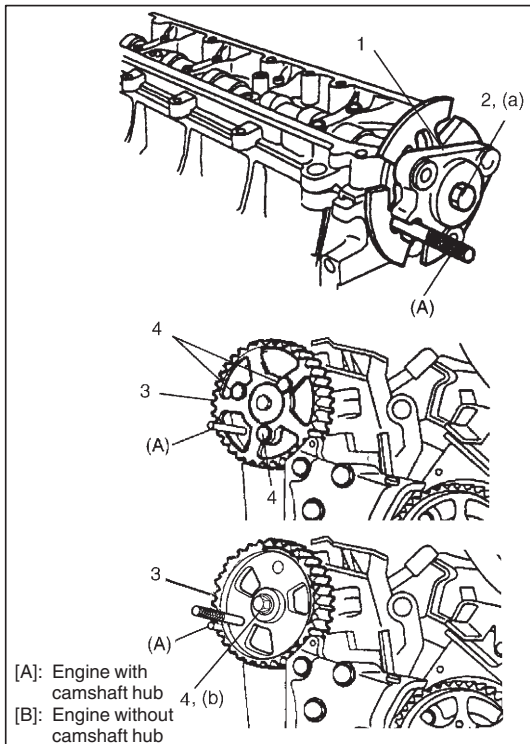

6) Install camshaft timing pulley as follows.

- For engine with camshaft hub
 - a) Install camshaft hub (1), if removed.
Tighten camshaft hub bolt (2) to specified torque by using special tool.

Special tool

(A): 09910-26540/OUT0000151

Tightening torque

Camshaft hub bolt (a): 45 N·m (4.5 kg·m, 32.5 lb·ft)

- b) Install camshaft timing belt pulley (3) and tighten camshaft timing belt pulley bolts (4) by hand.
- For engine without camshaft hub
 - a) Install camshaft timing belt pulley (3) and tighten camshaft timing belt pulley bolt (4) to specified torque.

Special tool

(A): 09910-26540/OUT0000151

Tightening torque

Camshaft timing pulley bolt (b): 52 N·m (5.2 kg·m, 37.5 lb·ft)

- 7) Install camshaft timing belt pulley and tighten bolts by hand.
- 8) Install vacuum pump to cylinder head referring to “VACUUM PUMP” in Section 6E3.
- 9) Install cylinder head cover referring to “CYLINDER HEAD COVER” in this section.
- 10) Install timing belt referring to referring to “TIMING BELT AND BELT TENSIONER (ENGINE WITH CAMSHAFT HUB)” or “TIMING BELT AND BELT TENSIONER (ENGINE WITHOUT CAMSHAFT HUB)” in this section.
- 11) Connect negative cable at battery.

Cylinder Head

- Remove all carbon from cylinder head surface.

NOTE:

Do not use any sharp-edged tool to scrape off carbon. Be careful not to scuff or nick metal surfaces when decarboning. The same applies to valves and valve seats, too.

- Check cylinder head for cracks in intake and exhaust ports, and head surface.

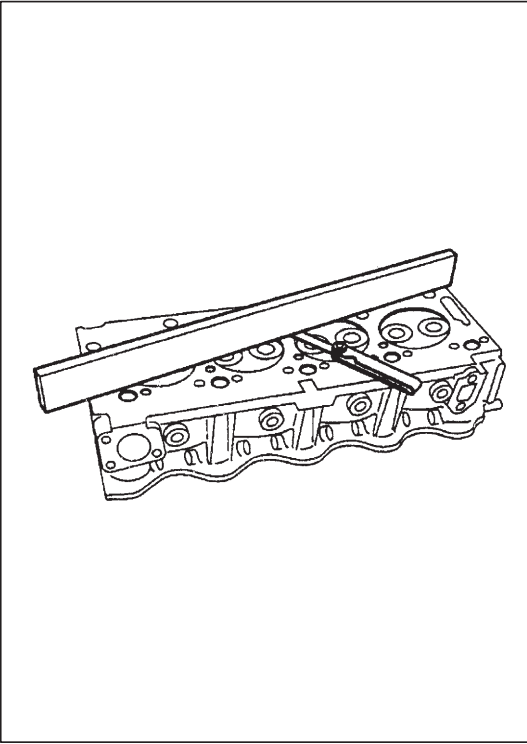

- Flatness of gasketed surface:

Using a straightedge and thickness gauge, check surface at 6 locations in total. If distortion limit, given below, is exceeded, correct gasketed surface with a surface plate and abrasive paper of about #400 (Waterproof silicon carbide abrasive paper): place paper on and over surface plate, and rub gasketed surface against paper to grind off high spots. Should this fail to reduce thickness gauge readings to within limit, replace cylinder head. Leakage of combustion gases from this gasketed joint is often due to warped gasketed surface: such leakage results in reduced power output.

Limit of distortion: 0.05 mm (0.002 in.)

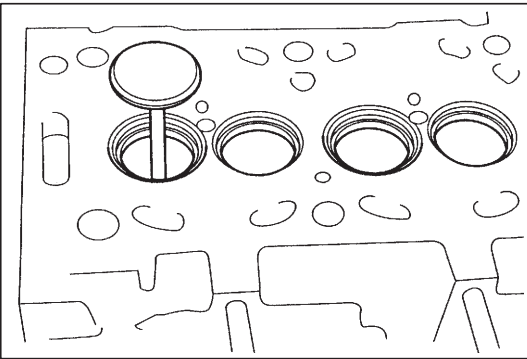

ASSEMBLY

- 1) Install valve to valve guide.

Before installing valve to valve guide, apply engine oil to stem seal, valve guide bore, and valve stem.

- 2) Install valve spring and spring retainer.

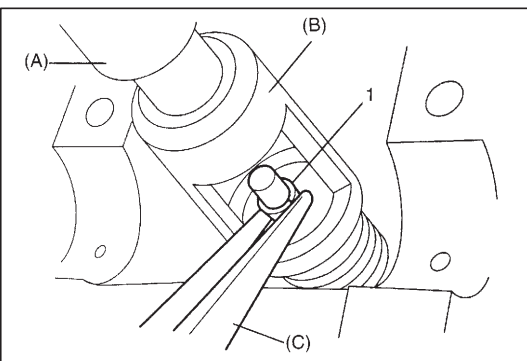

- 3) Using special tool (Valve lifter), compress valve spring and fit two valve cotters (1) into groove in valve stem.

Special Tool

(A): 09916-14510

(B): 09916-14910

(C): 09916-84511

- 4) Install valve rockers and camshaft referring to "CAMSHAFT AND VALVE ROCKERS" in this section.

- 5) Install intake manifold, exhaust manifold with turbocharger, water outlet box, injectors, common rail and glow plugs to cylinder head.

INSTALLATION

- 1) Clean mating surface of cylinder head and cylinder block.
Remove oil, old gasket and dust from mating surface.

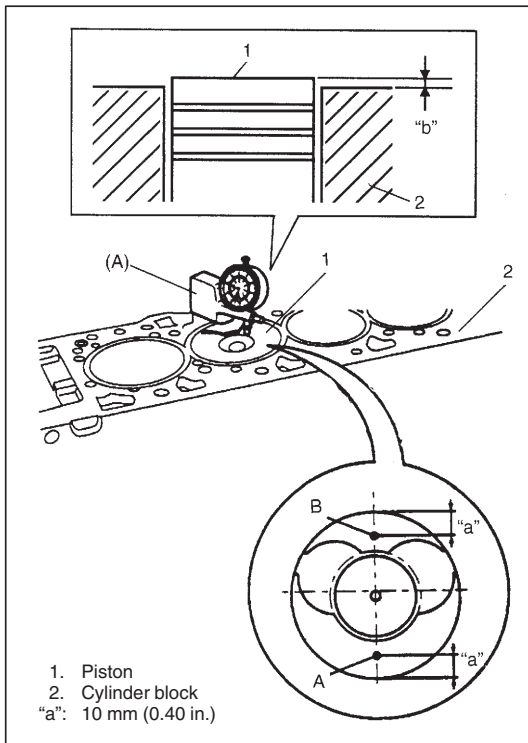

- 2) Prepare optimum cylinder head gasket according to following procedure.

- a) As shown in figure, piston projects above cylinder block when it reaches top dead center. Using special tool and dial gauge, measure projection "b" at two points "A" and "B" and take an average. Repeat this procedure with each piston.

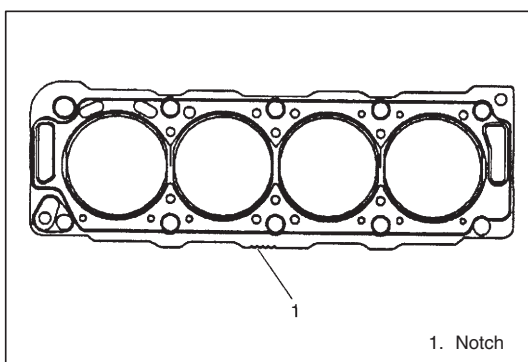
Special Tool**(A): 09910-26510/OUT 0000005**

- b) Using the largest value among averages obtained above, prepare optimum cylinder head gasket referring to table below.

Notch	Thickness of Gasket (mm (in.))	Measured Value (mm (in.))
1	1.24 – 1.36 (0.049 – 0.054)	0.470 – 0.604 (0.019 – 0.024)
2	1.29 – 1.41 (0.051 – 0.056)	0.605 – 0.654 (0.024 – 0.026)
3	1.34 – 1.46 (0.053 – 0.057)	0.655 – 0.704 (0.026 – 0.028)
4	1.39 – 1.51 (0.055 – 0.059)	0.705 – 0.754 (0.028 – 0.030)
5	1.44 – 1.56 (0.057 – 0.061)	0.755 – 0.830 (0.030 – 0.033)

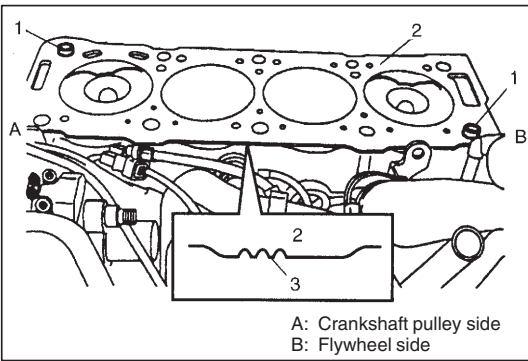

- 3) Install knock pins (1) to cylinder block.
- 4) Install new cylinder head gasket (2) to cylinder block. Thickness identification notch(es) (3) provided on gasket should come to oil filter side.

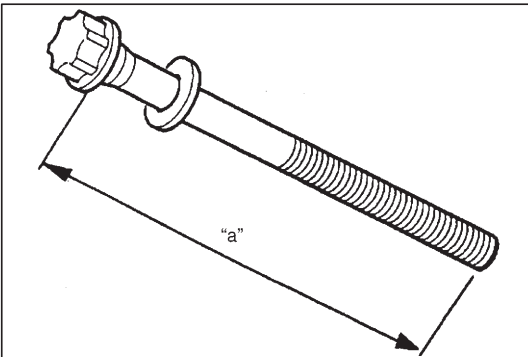

- 5) Check to make sure that length of cylinder head bolt as shown in figure does not exceed specified value.

“a”: Less than 133.4 mm (5.25 in.)

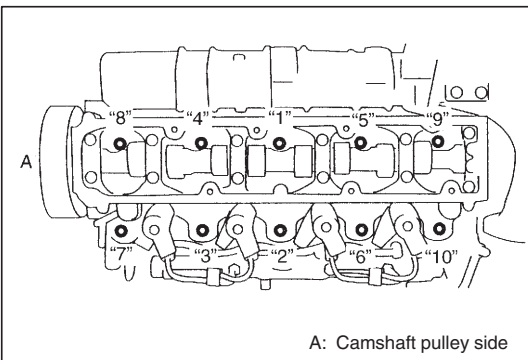

- 6) Apply engine oil to cylinder head bolts and tighten them gradually as follows.
 - a) Tighten all bolts to 20 N·m (2.0 kg-m, 14.5 lb-ft) according to numerical order in figure.
 - b) In the same manner as in Step a), tighten them to 60 N·m (6.0 kg-m, 43.5 lb-ft).
 - c) Retighten all bolts 220° according to numerical order in figure.

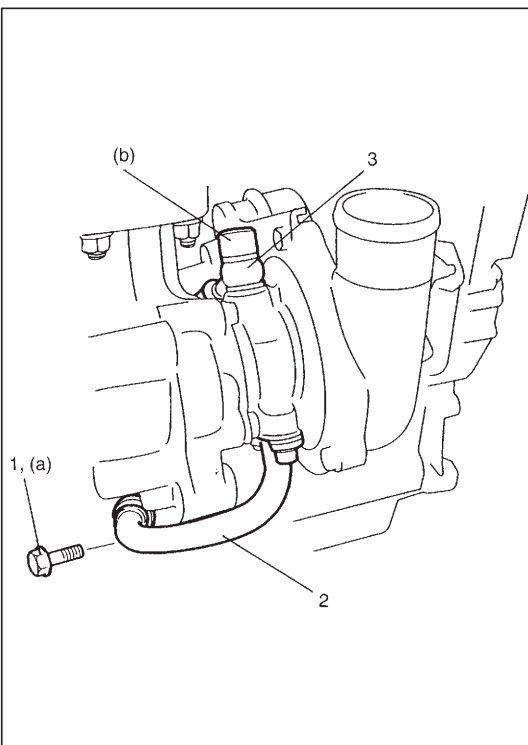

- 7) For installation, reverse removal procedure noting the following.
 - Install turbocharger bracket bolt (1). Tighten bolt to specified torque.

Tightening Torque

Turbocharger bracket bolt (a): 30 N·m (3.0 kg-m, 22.0 lb-ft)

- Using new gaskets, connect oil return pipe (2) and lubrication pipe (3) to turbocharger. Tighten bolt to specified torque.

Tightening Torque

Lubrication pipe union bolt (b): 20 N·m (2.0 kg-m, 14.5 lb-ft)

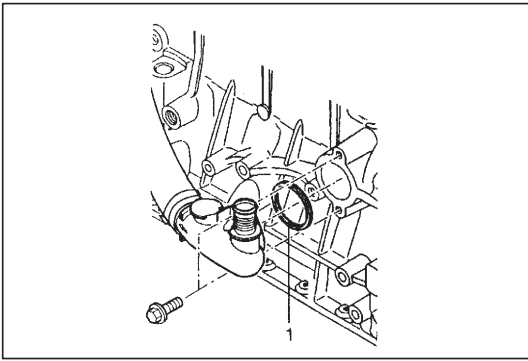

- Using new gasket (1), install water inlet box to cylinder block.

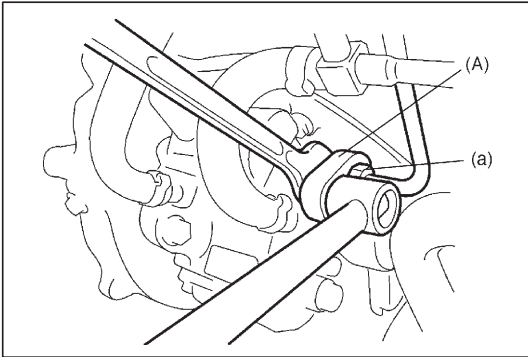

- Install high pressure supply pipe.
When tightening union nut, hold union nut of injection pump with special tool.

Special Tool

(A): 09950-76510/OUT0000148

Tightening Torque

High pressure supply pipe union nut (a):
20 N·m (2.0 kg-m, 14.5 lb-ft)

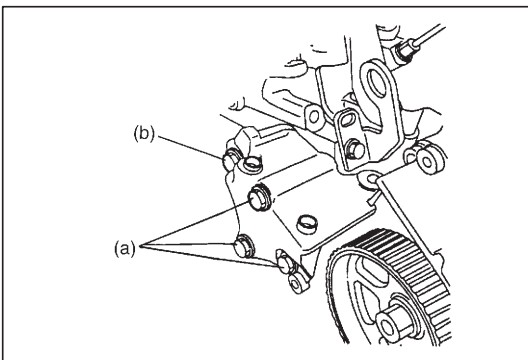

- Install engine bracket.

Tightening Torque

Engine bracket bolts No.1 (a): 45 N·m (4.5 kg-m, 32.5 lb-ft)
Engine bracket bolt No.2 (b): 20 N·m (2.0 kg-m, 14.5 lb-ft)

- Adjust generator belt tension referring to Section 6H.
- Adjust A/C compressor belt tension (if equipped) referring to Section 1B.
- Check to ensure that all removed parts are back in place. Reinstall any necessary parts which have not been reinstalled.
- Refill cooling system with coolant and A/T with specified A/T fluid (vehicle with A/T).
- Connect negative cable at battery.
- Check to make sure that there is no fuel leakage, coolant leakage, oil leakage, A/T fluid leakage (vehicle with A/T) and exhaust gas leakage at each connection.

PISTON, PISTON RINGS, CONNECTING RODS AND CYLINDERS

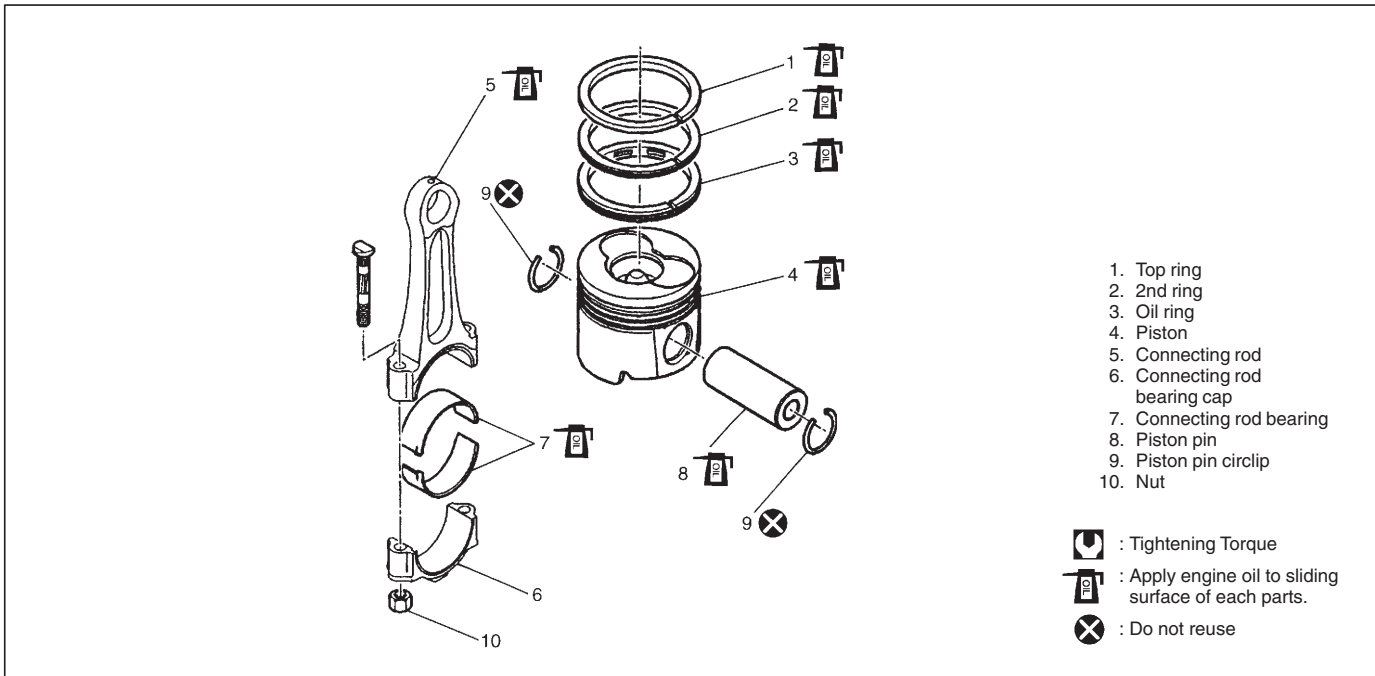

REMOVAL

- 1) Disconnect negative cable at battery.
- 2) Drain engine oil and engine coolant.
- 3) Remove oil pan and oil pump strainer referring to "OIL PAN AND OIL PUMP STRAINER" in this section.
- 4) Remove oil pump referring to "OIL PUMP" in this section.
- 5) Remove cylinder head referring to "VALVES AND CYLINDER HEAD" in this section.
- 6) Mark cylinder number on all pistons, connecting rods and rod bearing caps, using silver pencil or quick drying paint.
- 7) Remove oil level gauge lower guide (1) and oil partition (2).

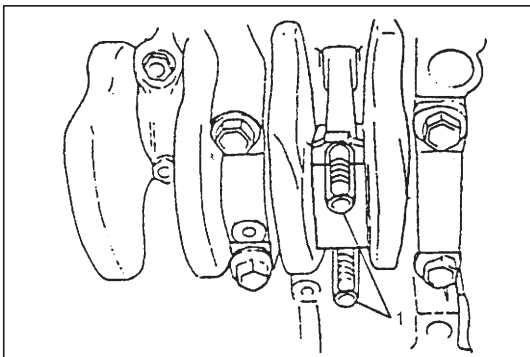
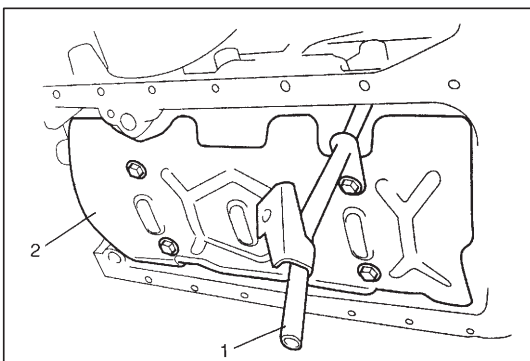

- 8) Remove rod bearing caps.
- 9) Install guide hose (1) over threads of rod bolts. This is to prevent damage to bearing journal and rod bolt threads when removing connecting rod.
- 10) Decarbon top of cylinder bore before removing piston from cylinder.
- 11) Push piston and connecting rod assembly out through the top of cylinder bore.

DISASSEMBLY

- 1) Using piston ring expander, remove two compression rings (Top and 2nd) and oil ring from piston.

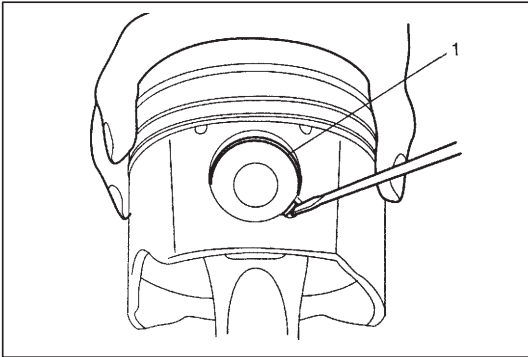

- 2) Remove piston pin from connecting rod.
 - Ease out piston pin circlips (1), as shown.

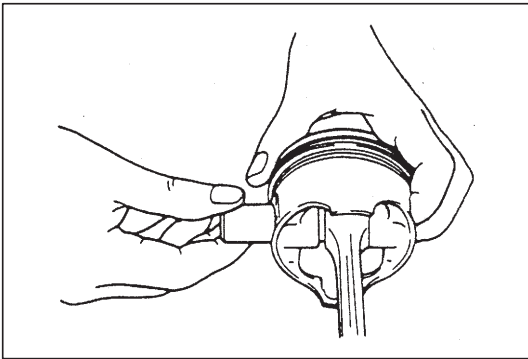

- Force piston pin out.

CLEANING

Clean carbon from piston head and ring grooves, using a suitable tool.

INSPECTION

Cylinders

- Inspect cylinder walls for scratches, roughness, or ridges which indicate excessive wear. If cylinder bore is very rough or deeply scratched, or ridged, rebore cylinder.

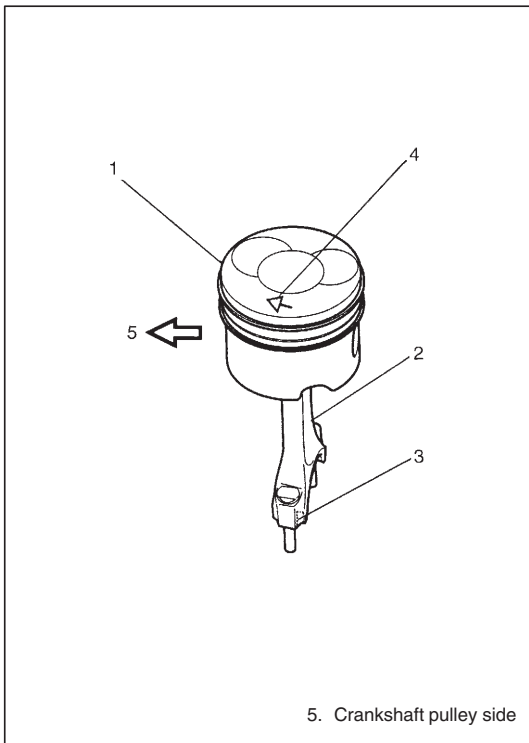

ASSEMBLY

- 1) Install piston pin to piston (1) and connecting rod (2):

After applying engine oil to piston pin and piston pin holes in piston and connecting rod, fit connecting rod to piston so that bearing lock tab (3) and arrow mark (4) come on the same side and insert piston pin to piston and connecting rod, and install piston pin circlips.

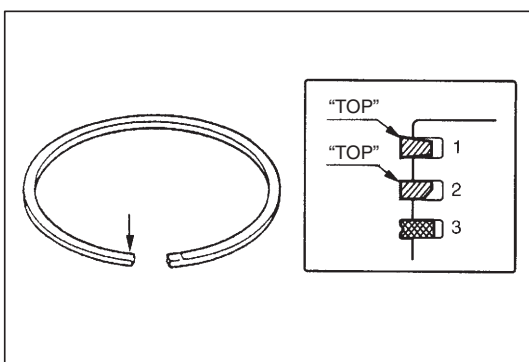

- 2) Install piston rings to piston:

- As indicated in figure at the left, 1st and 2nd rings have "TOP" mark respectively. When installing these piston rings to piston, direct marked side of each ring toward top of piston.
- 1st ring (1) differs from 2nd ring (2) in thickness, shape and color of surface contacting cylinder wall. Distinguish 1st ring from 2nd ring by referring to figure.
- When installing oil ring (3), install spacer first and then rail.

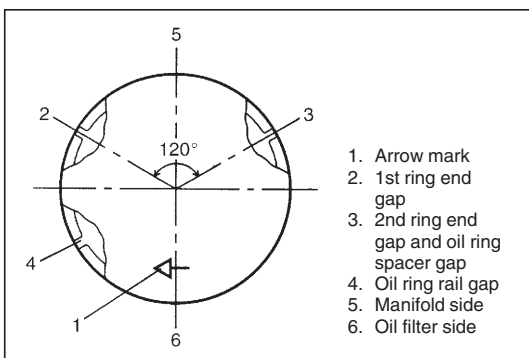

- 3) After installing three rings (1st, 2nd and oil rings), distribute their end gaps as shown in figure.

INSTALLATION OR CONNECTION

- 1) Apply engine oil to pistons, rings, cylinder walls, connecting rod bearings and crankpins.

NOTE:

Do not apply oil between connecting rod and bearing or between bearing cap and bearing.

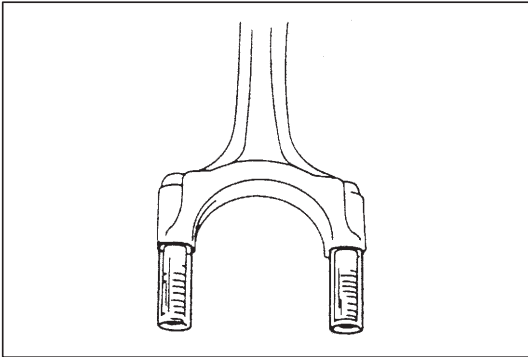

- 2) Install guide hoses over connecting rod bolts. These guide hoses protect crankpin and threads of rod bolt from damage during installation of connecting rod and piston assembly.

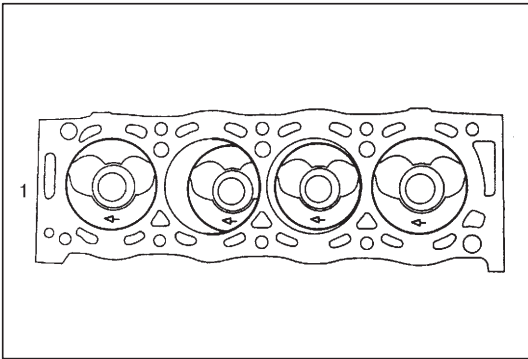

- 3) When installing piston and connecting rod assembly into cylinder bore, point arrow mark on piston head to crankshaft pulley side (1).

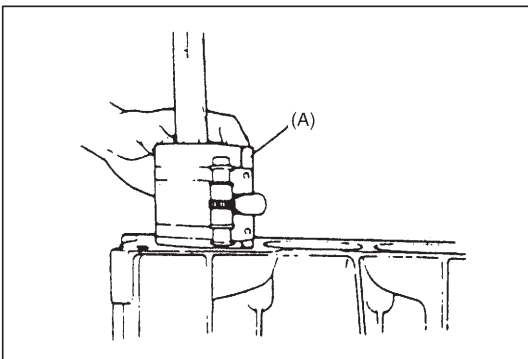

- 4) Install piston and connecting rod assembly into cylinder bore. Use special tool (Piston ring compressor) to compress rings. Guide connecting rod into place on crankshaft. Using a hammer handle, tap piston head to install piston into bore. Hold ring compressor firmly against cylinder block until all piston rings have entered cylinder bore.

Special Tool

(A): 09916-77310

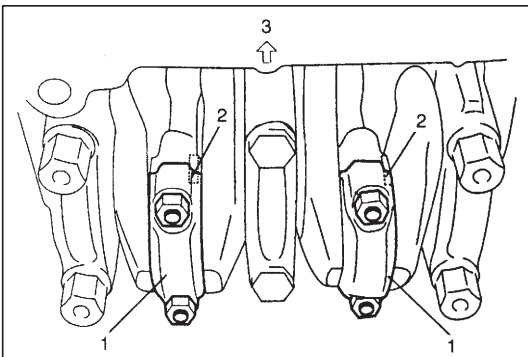

- 5) Install bearing cap (1): At this time, make sure that bearing lock tab (2) of bearing cap faces oil filter side (3).

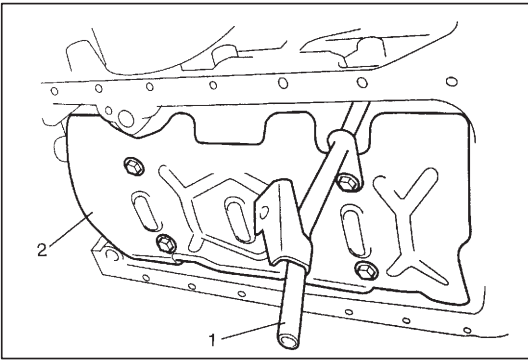

6) Install oil partition (2) and oil level gauge lower guide (1).

- 7) Reverse removal procedure for installation, as previously outlined.
- 8) Adjust generator belt tension, referring to Section 6H.
- 9) Adjust A/C compressor belt tension, if equipped. Refer to Section 1B.
- 10) Check to ensure that all removed parts are back in place. Reinstall any necessary parts which have not been reinstalled.
- 11) Refill engine with engine oil, referring to "ENGINE OIL CHANGE" in Section 0B.
- 12) Refill cooling system referring to "ENGINE COOLING" section.
- 13) Refill front differential housing with gear oil, referring to Section 7E of the Service Manual mentioned in this manual.
- 14) Connect negative cable at battery.
- 15) Check to make sure that there is no fuel leakage, coolant leakage, oil leakage and exhaust gas leakage at each connection.

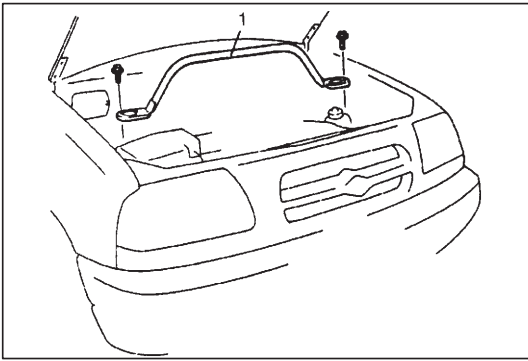

UNIT REPAIR OVERHAUL

ENGINE ASSEMBLY

REMOVAL

- 1) Disconnect negative cable at battery.
- 2) Remove engine hood after disconnecting windshield washer hose.
- 3) Remove TP sensor (Accelerator stroke sensor) and intake air pressure sensor, then remove strut tower bar (1).

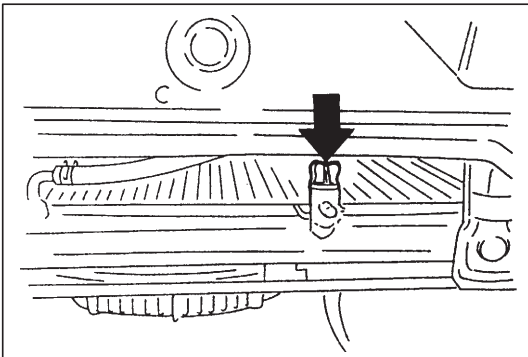

- 4) Drain cooling system.
- 5) Remove degassing tank and radiator with radiator fan motor assembly.
Refer to "ENGINE COOLING" section.
- 6) Remove air cleaner outlet hose.
- 7) Remove intercooler.
- 8) Remove transmission assembly referring to Section 7A or 7B.

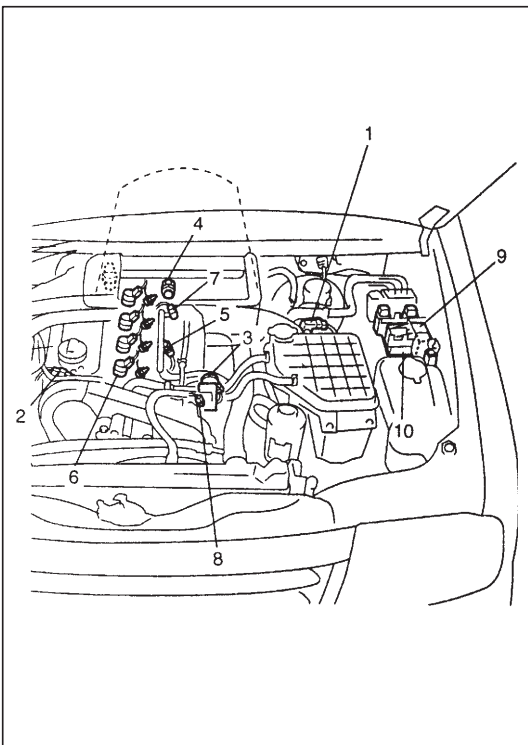

- 9) Disconnect following electric wires:
 - Intake air pressure sensor (1)
 - Camshaft position sensor (2)
 - Fuel pressure regulator (3)
 - Glow plug supply wire at the connector
 - Engine coolant temp. sensor (4)
 - Fuel pressure sensor (5) wire at the connector
 - Fuel injectors (6)
 - Fuel temp. sensor (7)
 - Injection pump solenoid valve (8)
 - Generator
 - Engine oil pressure switch
 - Double relay (9)
 - Pre post heating control unit (10)
 and then release wire harnesses from clamps.

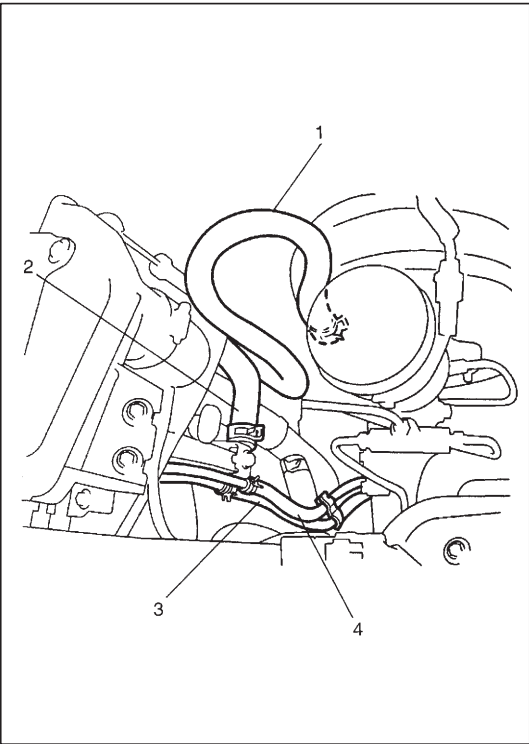

10) Disconnect following hoses:

- Brake booster hose (1) from vacuum pipe
- Vacuum hoses from solenoid valves
- Heater inlet and outlet hose (2) from pipe
- Fuel feed hose (3) and return hose (4) from each pipe
- A/T fluid hose clamp from bracket

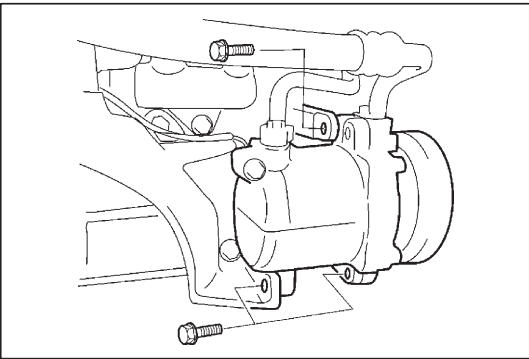

11) With hose connected, detach A/C compressor and power steering pump from bracket if equipped.

12) Drain engine oil if necessary.

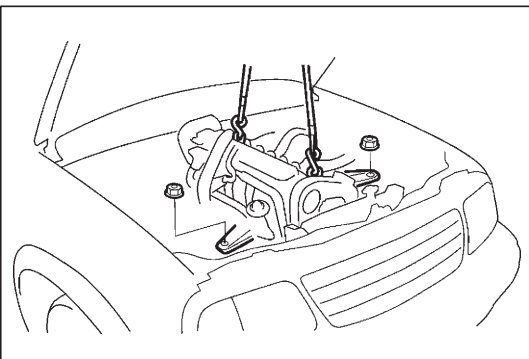

13) Install lifting device.

14) Remove engine mounting bracket nuts (R & L).

15) Before lifting engine, check to ensure all hoses, electric wires and cables are disconnected from engine.

16) Remove engine assembly from chassis.

With transmission disconnected, engine can be removed by lifting upwards.

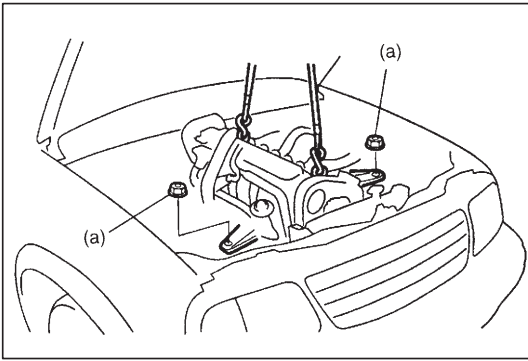

INSTALLATION

- 1) Lower engine assembly into engine compartment.
- 2) Tighten engine side mounting bracket nuts (R & L).

Tightening Torque

(a): 50 N·m (5.0 kg·m, 36.5 lb-ft)

- 3) Remove lifting device.
- 4) Reverse removal procedure for installation, noting following points.

CAUTION:

Before installing intake air pressure sensor hose, degrease connect part of hose and intercooler outlet hose. Otherwise hose may become detached and cause turbo system failure.

- Install transmission assembly referring to Section 7A or 7B.
- Adjust generator belt tension, referring to Section 6H.
- Adjust A/C compressor belt tension, if equipped. Refer to Section 0B.
- Check to ensure that all removed parts are back in place. Reinstall any necessary parts which have not been reinstalled.
- Refill engine with engine oil, referring to item "ENGINE OIL CHANGE" in Section 0B.
- Refill cooling system referring to "ENGINE COOLING" section.
- Check to make sure that there is no fuel leakage, coolant leakage and exhaust gas leakage at each connection.

MAIN BEARINGS, CRANKSHAFT AND CYLINDER BLOCK

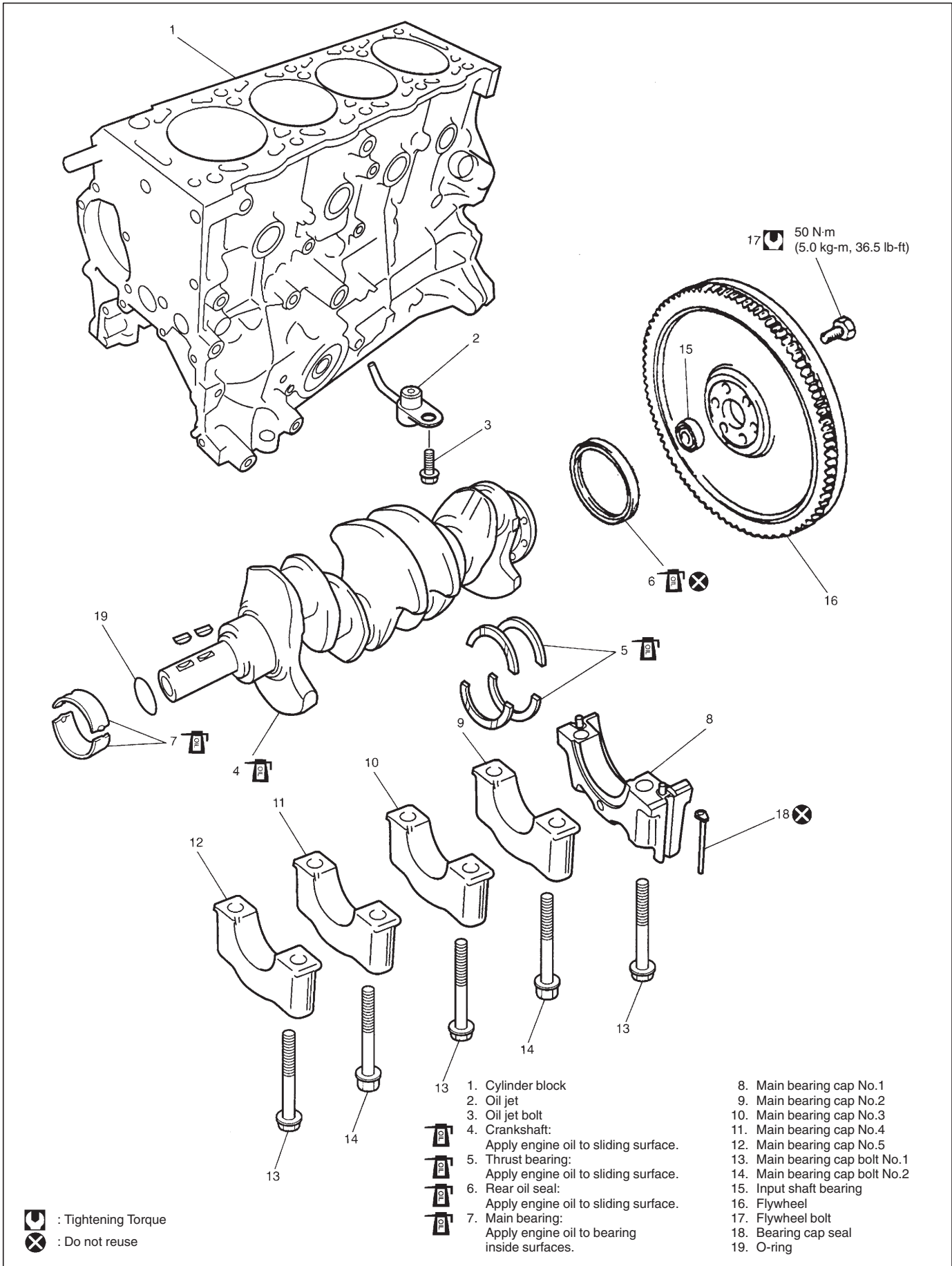

17 50 N-m
(5.0 kg-m, 36.5 lb-ft)

- 1. Cylinder block
- 2. Oil jet
- 3. Oil jet bolt
- 4. Crankshaft:
Apply engine oil to sliding surface.
- 5. Thrust bearing:
Apply engine oil to sliding surface.
- 6. Rear oil seal:
Apply engine oil to sliding surface.
- 7. Main bearing:
Apply engine oil to bearing inside surfaces.
- 8. Main bearing cap No.1
- 9. Main bearing cap No.2
- 10. Main bearing cap No.3
- 11. Main bearing cap No.4
- 12. Main bearing cap No.5
- 13. Main bearing cap bolt No.1
- 14. Main bearing cap bolt No.2
- 15. Input shaft bearing
- 16. Flywheel
- 17. Flywheel bolt
- 18. Bearing cap seal
- 19. O-ring

: Tightening Torque
 : Do not reuse

REMOVAL

- 1) Remove engine assembly from body as previously outlined.
- 2) Remove following parts from engine as previously outlined.
 - Oil pan and oil pump strainer
 - Intake manifold and exhaust manifold
 - Cylinder head cover
 - Timing belt cover
 - Timing belt, belt tensioner, roller and crankshaft timing belt pulley
 - Oil pump, oil pump drive sprocket and gasket holder plate
 - Cylinder head assembly
 - Piston and connecting rod

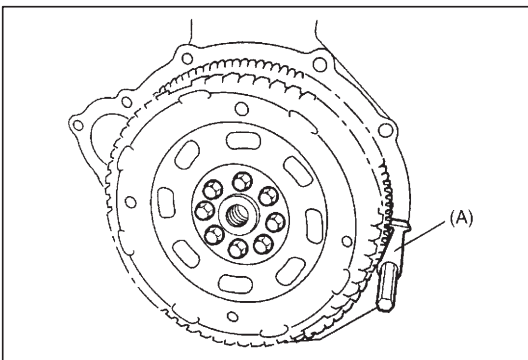

- 3) Remove clutch cover, clutch disc and flywheel (drive plate and CKP (Engine speed) sensor ring for A/T).

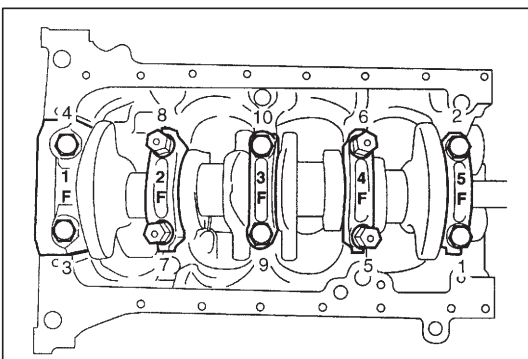
Special Tool**(A): 09924-17811**

- 4) Loosen crankshaft bearing cap bolts in such order as indicated in figure a little at a time and remove bearing caps.

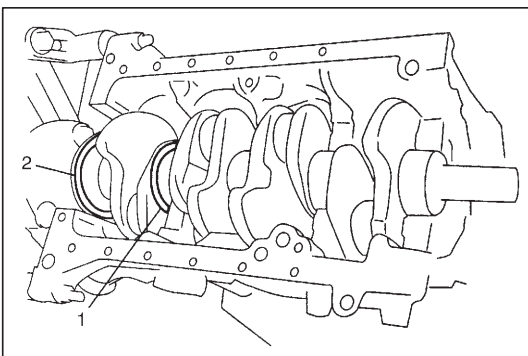

- 5) Remove thrust bearings (lower side) (1) and rear oil seal (2).
- 6) Remove crankshaft from cylinder block.
- 7) Remove thrust bearings (upper side).

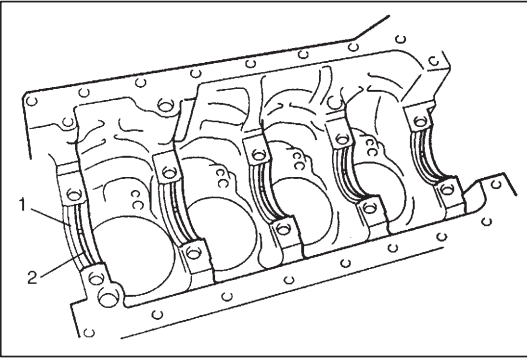

Main Bearings

General information

- Upper half of bearing (1) has oil groove (2) as shown in figure. Install this half with oil groove to cylinder block.

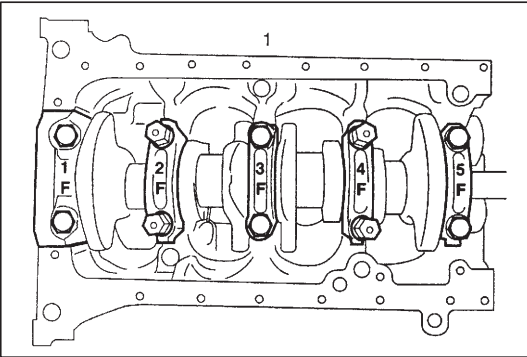

- On each main bearing cap, number is embossed as shown in figure.

When installing each bearing cap to cylinder block, point bearing lock tab toward oil filter side (1) and install each cap from that side to crankshaft pulley side in ascending order of numbers "1F", "2F", "3F", "4F" and "5F". Tighten cap bolts to specified torque.

Inspection

Check bearings for pitting, scratches, wear or damage.

If any malcondition is found, replace both upper and lower halves.

Never replace one half without replacing the other half.

Rear Oil Seal

Carefully inspect oil seal for wear or damage. If its lip is worn or damaged, replace it.

INSTALLATION**NOTE:**

- All parts to be installed must be perfectly clean.
- Be sure to apply oil to crankshaft journals, journal bearings, thrust bearings, crankpins, connecting rod bearings, pistons, piston rings and cylinder bores.
- Journal bearings, bearing caps, connecting rods, rod bearings, rod bearing caps, pistons and piston rings are in combination sets. Do not disturb such combination and make sure that each part goes back to where it came from, when installing.

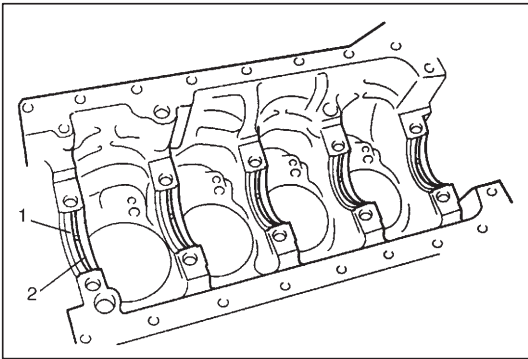

- 1) Install main bearings (1) to cylinder block.
One of two halves of main bearing, has an oil groove (2). Install it to cylinder block, and the other half without oil groove to bearing cap.

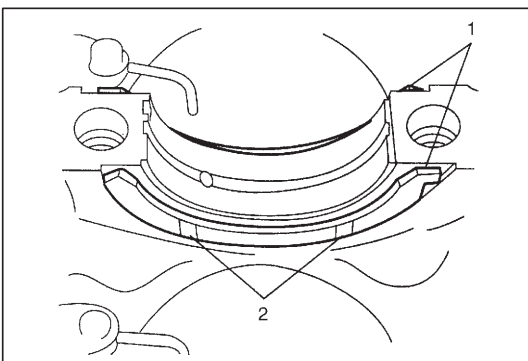

- 2) Install thrust bearings (1) to cylinder block between No.1 and No.2 cylinders. Face oil groove (2) sides to crank webs.
- 3) Install crankshaft to cylinder block.

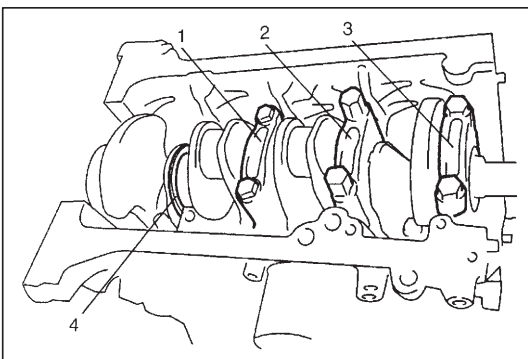

- 4) Install main bearing caps No.3 (1), No.4 (2) and No.5 (3).
- 5) Install thrust bearing (4) so that its oil groove faces flywheel side.

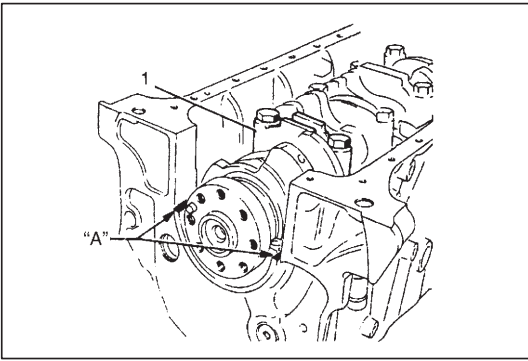

- 6) Install main bearing cap No.2 (1).
- 7) Apply sealant to the end of cylinder block as shown in figure.

“A” Sealant: 99000-31140

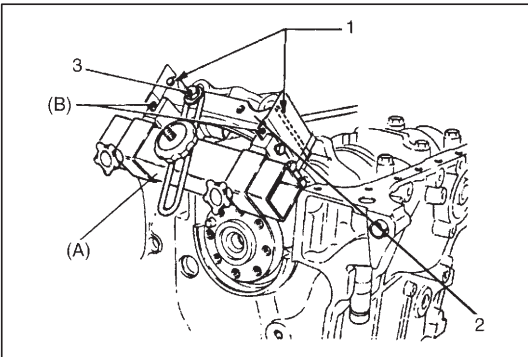

- 8) Fit new bearing cap seal (1) to main bearing cap No.1 (2).
- 9) Attach special tools (A) and (B) to main bearing cap No.1 by using bolt and washer (3).

Special Tool

(A): 09911-16510/OUT0000002

(B): 09913-96510/OUT0000012

- 10) Apply oil to shims and their contact surface on block.

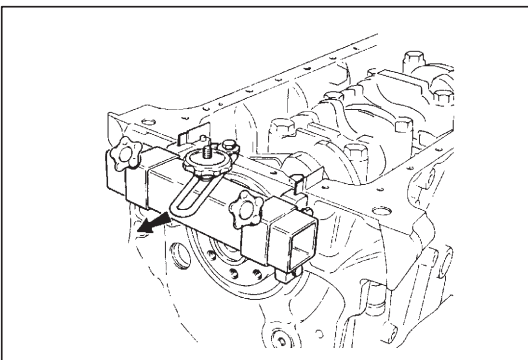

- 11) Install main bearing cap No.1 according to the following procedure.
 - a) Engage cap into block at a 45° angle.
 - b) Straighten it out.
 - c) Lower it slowly into block.
 - d) Remove bolt that holds special tool to cap.
 - e) Tighten both main bearing cap bolts temporarily.
 - f) Remove special tool straight out toward flywheel.

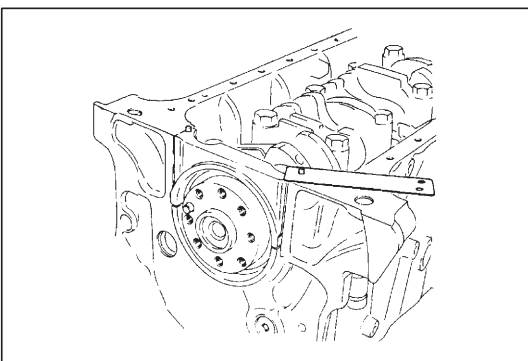

- 12) Cut side seals so that they protrude from cylinder block about 2 mm (0.08 in.).

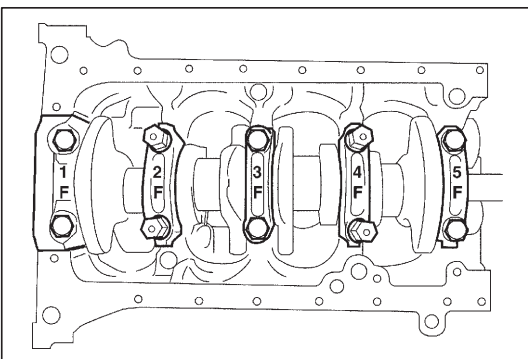

- 13) Tighten bearing cap bolts in such order as shown in figure a little at a time.

NOTE:

After tightening cap bolts, check to be sure that crankshaft rotates smoothly.

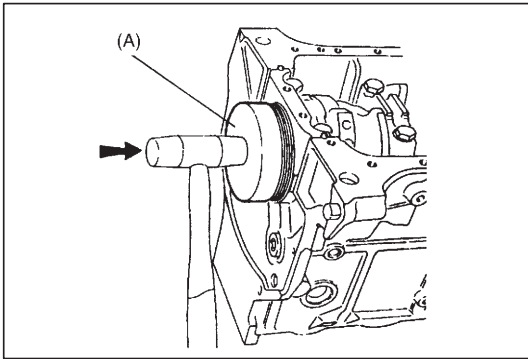

- 14) Place a new rear oil seal on special tool.

Special Tool

(A): 09911-16520/OUT0000011

- 15) Install rear oil seal, tapping it with plastic hammer until it fully seats.
 16) Remove special tool by turning and pulling it out in direction of engine rotation.
 17) Check that visible lip of rear oil seal faces outside.

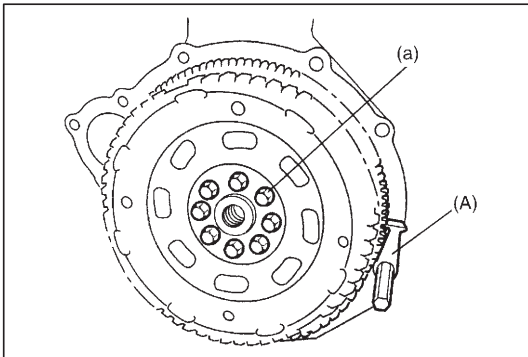

- 18) Install flywheel (M/T model) or drive plate and CKP (Engine speed) sensor ring (A/T model).
 Using special tool, lock flywheel or drive plate.

Special Tool

(A): 09924-17811

Tightening Torque

(a): 50 N·m (5.0 kg-m, 36.5 lb-ft)

- 19) Install following parts to engine as previously outlined.
- Piston and connecting rod
 - Cylinder head assembly
 - Oil pump, oil pump drive sprocket and gasket holder plate
 - Timing belt, belt tensioner, roller and crankshaft timing sprocket
 - Timing belt cover
 - Cylinder head cover
 - Intake manifold and exhaust manifold
 - Oil pan and oil pump strainer
- 20) Install clutch to flywheel (vehicle with M/T) referring to Section 7C.

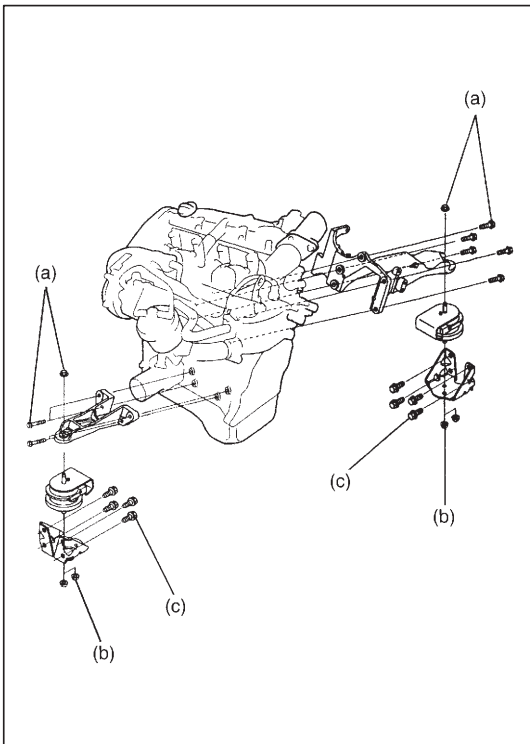

21) Install engine mounting brackets.

Tightening Torque

Engine side mounting nuts and bolts (a):

50 N·m (5.0 kg-m, 36.5 lb-ft)

Frame side mounting bracket nuts (b):

50 N·m (5.0 kg-m, 36.5 lb-ft)

Frame side mounting bracket bolts (c):

85 N·m (8.5 kg-m, 61.5 lb-ft)

22) Install engine assembly to vehicle as previously outlined.

SPECIAL TOOLS

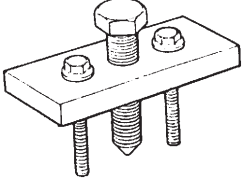
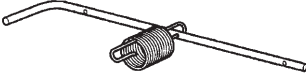
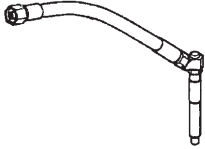
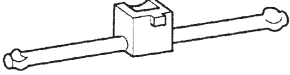
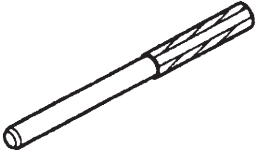
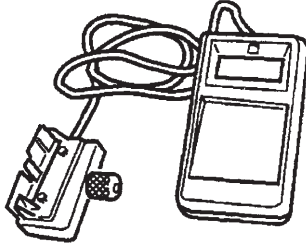
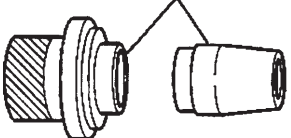
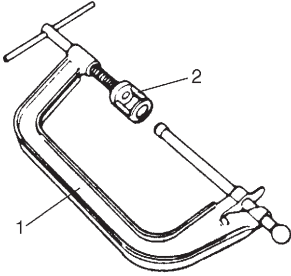
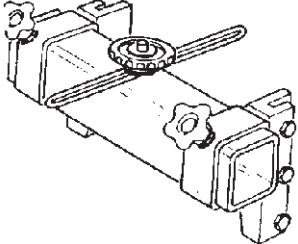
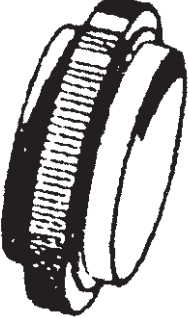
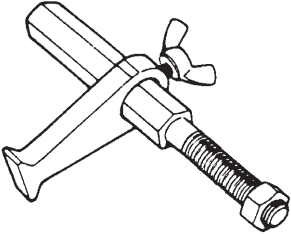
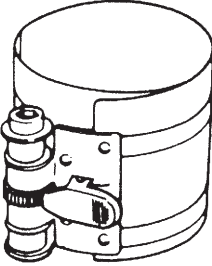
 <p>09919-46510 (OUT0000110) Clamp pliers</p>	 <p>09944-36011 Steering wheel remover</p>	 <p>09910-26530 (OUT0000160) TDC rod positioner</p>	 <p>09916-96520 Compression gauge attachment</p>
 <p>09919-56550 (OUT0000141) Tension lever</p>	 <p>09910-26540 (OUT0000151) Camshaft TDC positioner</p>	 <p>09919-56560 (OUT0000138) Tension measuring equipment</p>	 <p>09913-56510 (OUT0000152) Oil seal installer</p>
 <p>09910-26510 (OUT0000005) Dial gauge support</p>	 <p>1. 09916-14510 Valve lifter 2. 09916-14910 Valve lifter attachment</p>	 <p>09916-84511 Forceps</p>	 <p>09911-16510 (OUT0000002) Rear oil seal installer</p>
 <p>09911-16520 (OUT0000011) Rear main seal installer</p>	 <p>09924-17811 Flywheel holder</p>	 <p>09916-77310 Piston ring compressor</p>	 <p>09915-76530 (OUT0000057) Oil pressure gauge kit</p>

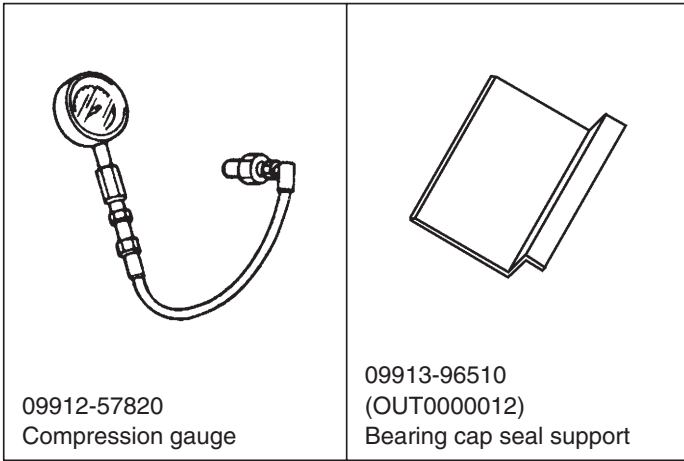

REQUIRED SERVICE MATERIALS

RECOMMENDED SUZUKI PRODUCT	USE
Sealant 1207C 99000-31150	<ul style="list-style-type: none"> ● To apply to mating surfaces of cylinder block and oil pan. ● To apply to mating surfaces of cylinder block and gasket holder plate.
Sealant 1207B 99000-31140	<ul style="list-style-type: none"> ● To apply to mating surface of camshaft housing cylinder head. ● To apply to mating surfaces of cylinder block and main bearing cap No.1.

TIGHTENING TORQUE SPECIFICATION

Fastening part	Tightening torque		
	N·m	kg-m	lb-ft
Camshaft housing bolts	10.0	1.0	7.5
Cylinder head cover bolts	10.0	1.0	7.5
Oil pan bolts	16.0	1.6	11.5
Oil pan drain plug bolt	34.0	3.4	24.5
Cylinder head bolts	a) Tighten 60 N·m b) Turn 220°	a) Tighten 6.0 kg-m b) Turn 220°	a) Tighten 43.5 lb-ft b) Turn 220°
Frame side mounting bracket bolts	85.0	8.5	61.5
Engine side mounting bracket bolts and nuts	50.0	5.0	36.5
Frame side mounting bracket nuts	50.0	5.0	36.5
Crankshaft pulley bolts	a) Tighten 40 N·m b) Tighten 195 N·m by turning about 50°	a) Tighten 4.0 kg-m b) Tighten 19.5 kg-m by turning about 50°	a) Tighten 29.0 lb-ft b) Tighten 141 lb-ft by turning about 50°
Flywheel bolts	50.0	5.0	36.5
Camshaft timing belt pulley bolt	25.0	2.5	18.0
Roller bolt	45.0	4.5	32.5
Timing belt tensioner bolt	25.0	2.5	18.0
Front suspension frame bolts	85.0	8.5	61.5
Camshaft hub bolts	45.0	4.5	32.5
Turbocharger bracket bolts	30.0	3.0	22.0
Lubrication pipe union bolt	20.0	2.0	14.5
High pressure supply pipe union nut	20.0	2.0	14.5
Engine bracket bolts No.1	45.0	4.5	32.5
Engine bracket bolt No.2	20.0	2.0	14.5

SECTION 6B

ENGINE COOLING

WARNING:

For vehicles equipped with Supplemental Restraint (Air Bag) System:

- Service on and around the air bag system components or wiring must be performed only by an authorized SUZUKI dealer. Refer to “System Components and Wiring Location View” under “General Description” in air bag system section in order to confirm whether you are performing service on or near the air bag system components or wiring. Please observe all WARNINGS and “Precautions” in air bag system section before performing service on or around the air bag system components or wiring. Failure to follow WARNINGS could result in unintentional activation of the system or could render the system inoperative. Either of these two conditions may result in severe injury.
- Technical service work must be started at least 90 seconds after the ignition switch is turned to the “LOCK” position and the negative cable is disconnected from the battery. Otherwise, the system may be activated by reserve energy in the Sensing and Diagnostic Module (SDM).

6B

NOTE:

For the description (items) not found in this section of this manual, refer to the same section of Service Manual mentioned in FOREWORD of this manual.

CONTENTS

GENERAL DESCRIPTION	6B- 2
DIAGNOSIS	6B- 5
MAINTENANCE	6B- 6
Coolant Level	6B- 6
Cooling System Service	6B- 6
Cooling System Flush and Refill	6B- 7
ON-VEHICLE SERVICE	6B- 9
Cooling System Draining	6B- 9
Cooling Water Pipes or Hoses	6B- 9
Thermostat	6B-10
Radiator	6B-11
Radiator Fan Relay	6B-12
Water Pump	6B-13
REQUIRED SERVICE MATERIALS	6B-14

GENERAL DESCRIPTION

The cooling system consists of the degassing tank cap, radiator, degassing tank, hoses, water pump, cooling fan, thermostat. The radiator is of tube-and-fin type.

COOLING SYSTEM CIRCULATION

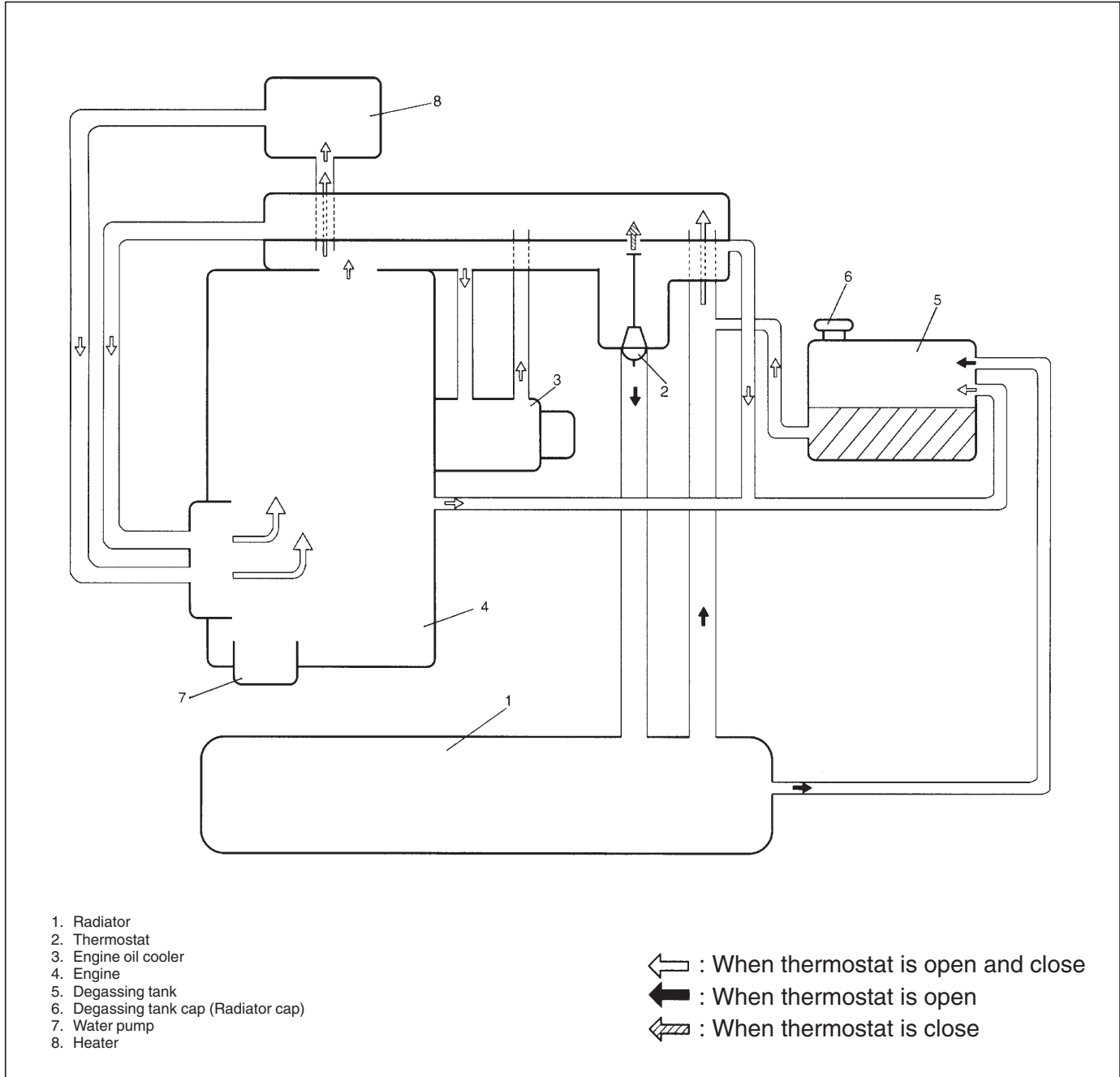

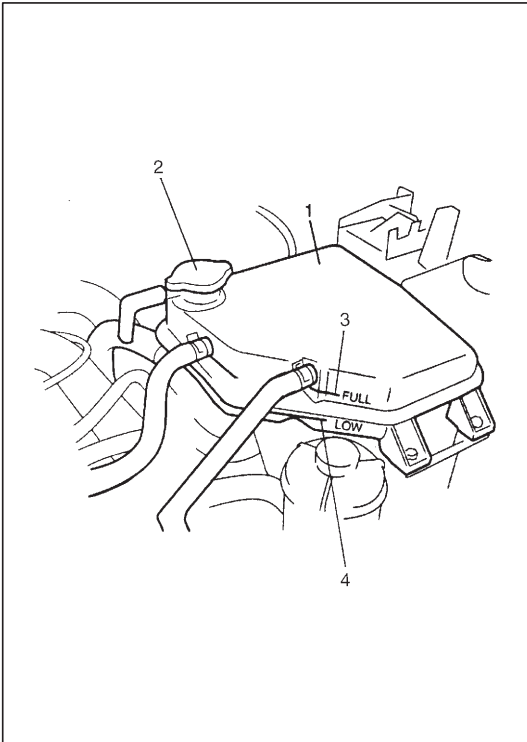

COOLANT DEGASSING TANK

The degassing tank (1) consists of a “see-through” plastic tank, a hose and a degassing tank cap (2).

During operation, the coolant circulates inside of the degassing tank constantly. As the coolant warms up and expands, the coolant level in the degassing tank rises. On the other hand, it lowers as the coolant cools down and contracts. When the pressure applied to the inside of the degassing tank constantly exceeds the specified value, the pressure is relieved through the degassing tank cap.

Thus, the radiator is kept filled with coolant to the desired level at all times, resulting in increased cooling efficiency.

Coolant level should be between “FULL” (3) and “LOW” (4) marks on the degassing tank.

Coolant should be added only to the degassing tank as necessary.

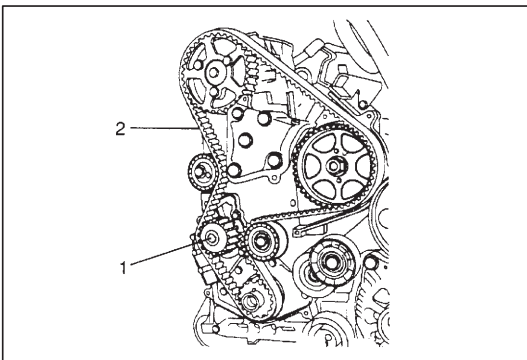

WATER PUMP

The water pump (1) is driven by timing belt (2).

The water pump can not be disassembled.

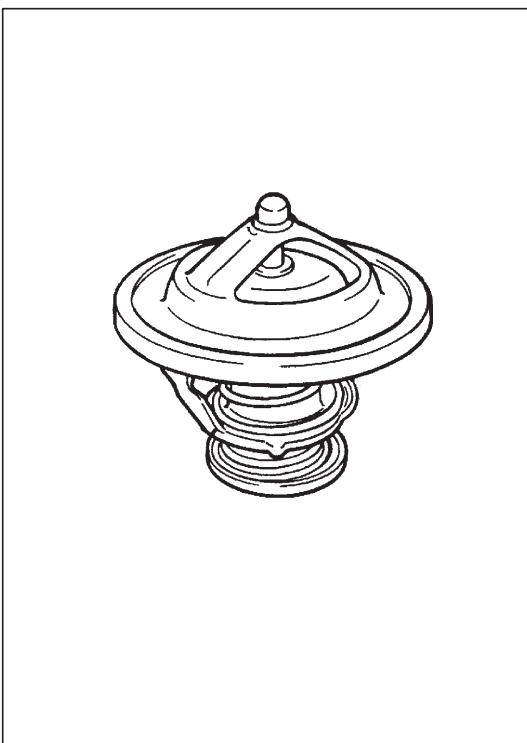

THERMOSTAT

A wax pellet type thermostat is used in the coolant outlet passage to control the flow of engine coolant, to provide fast engine warm up and to regulate coolant temperatures.

A wax pellet element is hermetically contained in a metal case, and expands when heated and contracts when cooled.

When the pellet is heated and expands, the metal case pushed down the valve to open it.

As the pellet is cooled, the contraction allows the spring to close the valve.

Thus, the valve remains closed while the coolant is cold, preventing circulation of coolant through the radiator.

At this point, coolant is allowed to circulate only throughout the engine to warm it quickly and evenly.

As the engine warms, the pellet expands and the thermostat valve opens, permitting coolant to flow through the radiator.

Thermostat functional spec. $\pm 1.5^{\circ}\text{C}$ (2.7°F)	
Temp. at which valve begins to open	83°C (181°F)
Temp. at which valve becomes fully open	95°C (203°F)

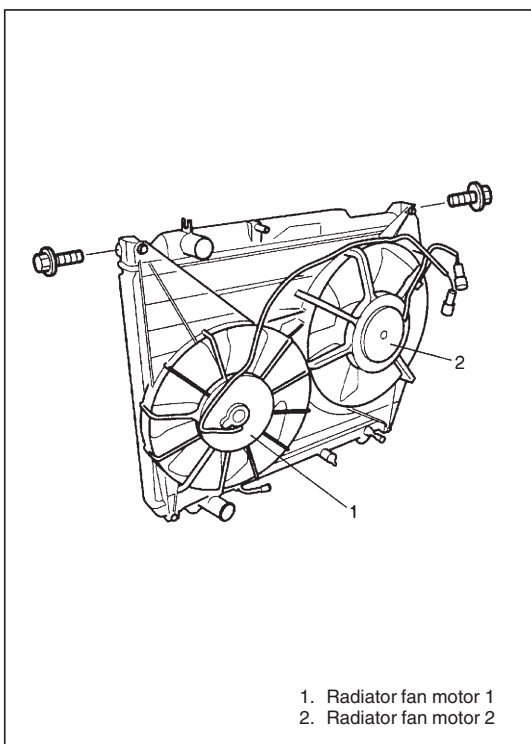

COOLING FAN

The cooling fan is driven by electric motor, and the motor is activated by ECM (and ECT sensor).

WARNING:

Keep hands, tools, and clothing away from engine cooling fan to help prevent personal injury. This fan is electric and can come on whether or not the engine is running. The fan can start automatically in response to the relays with the ignition switch in the "ON" position.

ANTI-FREEZE PROPORTIONING CHART

Freezing temperature	°C	-16	-36
	°F	3	-33
Antifreeze/ Anticorrosion coolant concentration	%	30	50
Ratio of compound to cooling water	ltr.	2.8/6.4	4.6/4.6
	US pt.	5.9/13.5	9.7/9.7
	Imp. pt.	4.9/11.3	8.1/8.1

COOLANT CAPACITY

Engine, radiator, heater and de- gassing tank etc.	9.2 liters (19.4/16.2 US/Imp.p.)
--	-------------------------------------

COOLANT

The cooling system has been filled at the factory with a quality coolant that is a 50/50 mixture of water and ethylene glycol antifreeze.

This 50/50 mixture coolant solution provides freezing protection to -36°C (-33°F).

- Maintain cooling system freeze protection at -36°C (-33°F) to ensure protection against corrosion and loss of coolant from boiling.

This should be done even if freezing temperatures are not expected.

- Add ethylene glycol base coolant when coolant has to be added because of coolant loss or to provide added protection against freezing at temperature lower than -36°C (-33°F).

NOTE:

- Alcohol or methanol base coolant or plain water alone should not be used in cooling system at any time as damage to cooling system could occur.
- Even in a market where no freezing temperature is anticipated, mixture 70% water and 30% ethylene glycol antifreeze (Antifreeze/Anticorrosion coolant) should be used for the purpose of corrosion protection and lubrication.
- "Hard water", if used, will foul up the cooling circuit by scale formation. Tap water available from city water supply is the best available water, in a practical sense, for the cooling system. Distilled water is ideal but is a luxury in most cases.

DIAGNOSIS

Condition	Possible cause	Correction
Engine overheats	<ul style="list-style-type: none"> ● Not enough coolant ● Faulty thermostat ● Faulty water pump ● Dirty or bent radiator fins ● Coolant leakage on cooling system ● Defective cooling fan motor ● Faulty fan motor control circuit ● Plugged radiator ● Faulty degassing tank cap ● Dragging brakes ● Slipping clutch 	<p>Check coolant level and add as necessary.</p> <p>Replace.</p> <p>Replace.</p> <p>Clean or remedy.</p> <p>Repair.</p> <p>Check and replace as necessary.</p> <p>Repair or replace</p> <p>Check and replace radiator as necessary.</p> <p>Replace.</p> <p>Adjust brake.</p> <p>Adjust or replace.</p>

MAINTENANCE

COOLANT LEVEL

To check level, lift hood and look at “see-through” degassing tank (1).

It is not necessary to remove degassing tank cap (2) to check coolant level.

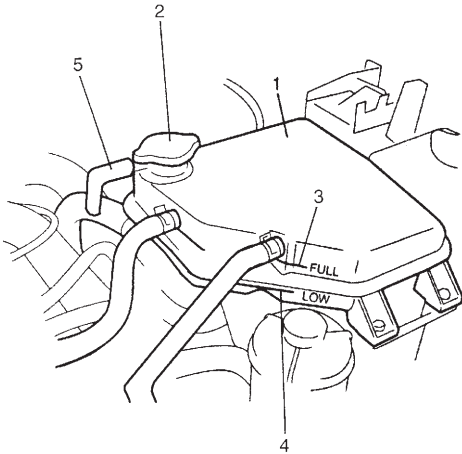

WARNING:

To help avoid danger of being burned:

- Do not remove degassing tank cap while coolant is “boiling”, and
- Do not remove degassing tank cap while engine and radiator are still hot.
- Scalding fluid and steam can be blown out under pressure if cap is taken off too soon.

When engine is cool, check coolant level in degassing tank.

A normal coolant level should be between “FULL” (3) and “LOW” (4) marks on degassing tank.

If coolant level is below “LOW” mark, remove degassing tank cap and add proper coolant to tank to bring coolant level up to “FULL” mark. Then, install degassing cap, making sure that the ear of cap lines up with degassing tank pipe (5).

NOTE:

If proper quality antifreeze is used, there is no need to add extra inhibitors or additives that claim to improve system. They may be harmful to proper operation of system, and are unnecessary expense.

COOLING SYSTEM SERVICE

WARNING:

To help avoid danger of being burned, do not remove radiator cap while engine and radiator are still hot. Scalding fluid and steam can be blown out under pressure if cap is taken off too soon.

Cooling system should be serviced as follows.

- 1) Check cooling system for leakage or damage.
- 2) Wash degassing tank cap and filler neck with clean water by removing degassing tank cap when engine is cold.
- 3) Check coolant for proper level and freeze protection.

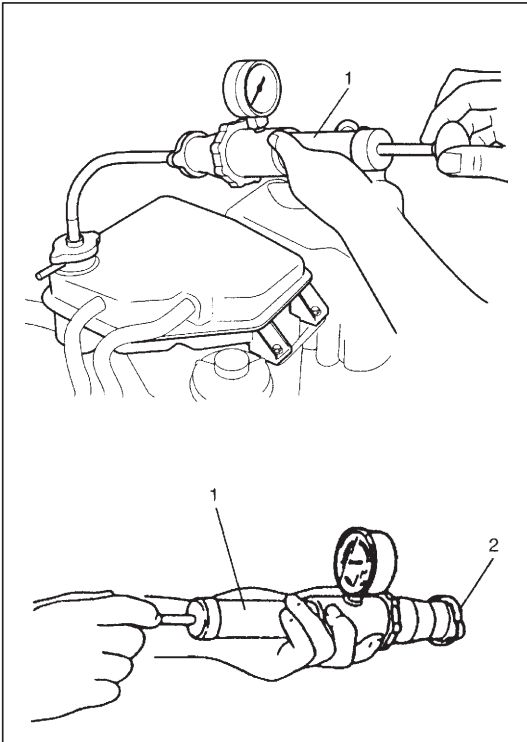

- 4) Using a pressure tester (1), check system and degassing tank cap (2) for proper pressure holding capacity 110 kpa (1.1 kg/cm², 15.6 psi). If replacement of cap is required, use proper cap specified for this vehicle.

NOTE:

After installing degassing tank cap to degassing tank, make sure that it is closed certainly as shown in figure. If not, turn cap more as shown figure.

- 5) Tighten hose clamps and inspect all hoses. Replace hoses whenever cracked, swollen or otherwise deteriorated.
6) Clean frontal area of radiator core.

COOLING SYSTEM FLUSH AND REFILL

- 1) Remove degassing tank cap when engine is cool.
Turn cap slowly to the left until it reaches a "stop" (Do not press down while turning it).
Wait until pressure is relieved (indicated by a hissing sound) then press down on cap and continue to turn it to the left.

WARNING:

To help avoid danger of being burned, do not remove degassing tank cap while engine and radiator are still hot. Scalding fluid and steam can be blown out under pressure if cap is taken off too soon.

- 2) With degassing tank cap removed, run engine until upper radiator hose is hot (this shows that thermostat is open and coolant is flowing through system).

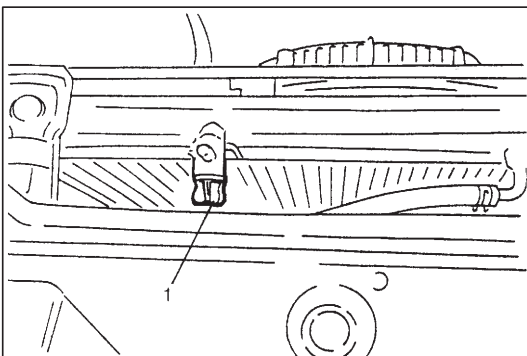

- 3) Stop engine and open radiator drain plug (1) to drain coolant.
4) Close drain plug.

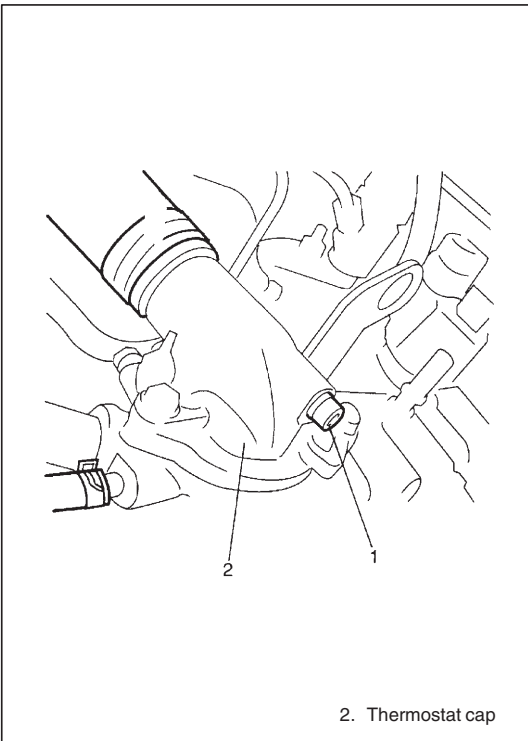

- 5) Fill the circuit slowly with water.
- 6) Loosen bleed screw (1) to bleed air and tighten it after confirmation of overflow.
- 7) Run engine until upper radiator hose is hot again.
- 8) Repeat steps 3) and 7) several times until drained liquid is nearly colorless.
- 9) Drain cooling system and then close radiator drain plug tightly.

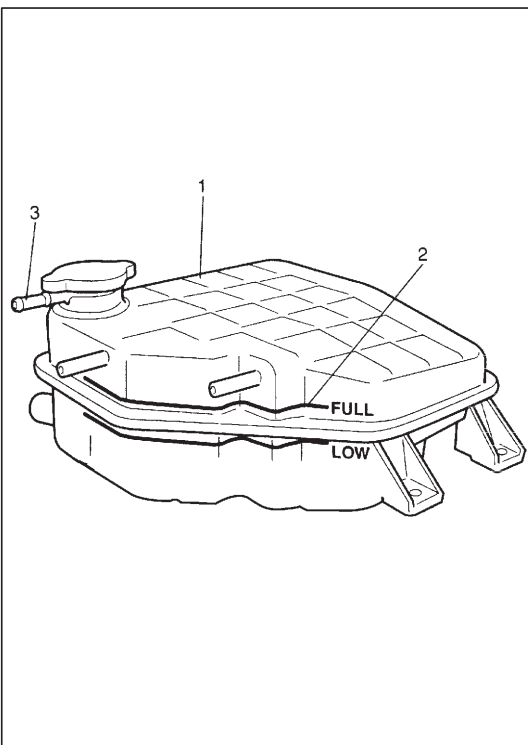

- 10) Disconnect hoses from degassing tank (1). Remove degassing tank and pour out any fluid. Scrub and clean inside of degassing tank with soap and water. Flush it well with clean water and drain.
Reinstall degassing tank and hose.
- 11) Add 50/50 mixture of good quality ethylene glycol antifreeze and water to degassing tank.
Fill to "FULL" level mark (2). Loosen bleed screw to bleed air and tighten it after confirmation of overflow.
- 12) Run engine, with degassing tank cap removed, until radiator upper hose is hot.
- 13) With engine idling, add coolant to degassing tank until level reaches "FULL" mark.
Install degassing tank cap, making sure that the ear of cap lines up with degassing tank pipe (3).

ON-VEHICLE SERVICE

WARNING:

- Check to make sure that engine coolant temperature is cold before removing any part of cooling system.
- Also be sure to disconnect negative cord from battery terminal before removing any part.

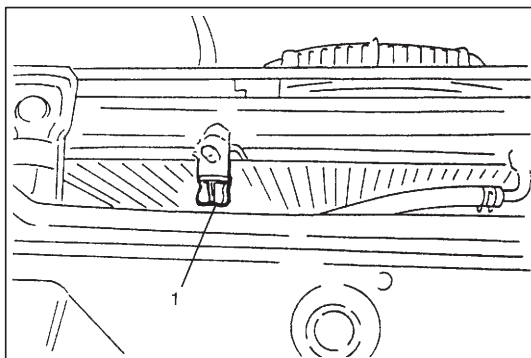

COOLING SYSTEM DRAINING

- 1) Remove degassing tank cap.
- 2) Loosen drain plug (1) on radiator to drain coolant.
- 3) After draining coolant, be sure to tighten drain plug securely.
- 4) Fill cooling system. Refer to "COOLANT" and steps 8) to 10) of "COOLING SYSTEM FLUSH AND REFILL" in this section.

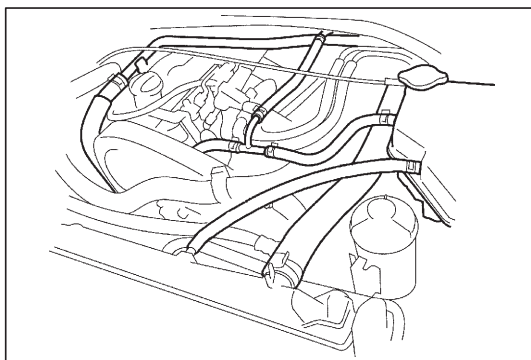

COOLING WATER PIPES OR HOSES

REMOVAL

- 1) Drain cooling system.
- 2) To remove these pipes or hoses, loosen clamp on each hose and pull hose end off.

INSTALLATION

Install removed parts in reverse order of removal procedure, noting the following.

- Tighten each clamp securely.
- Refill cooling system with proper coolant, referring to description on "COOLANT" and steps 8) to 10) of "COOLING SYSTEM FLUSH AND REFILL" in this section.

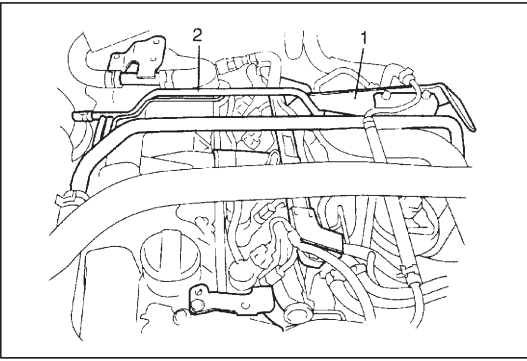

THERMOSTAT

REMOVAL

- 1) Disconnect negative cable at battery.
- 2) Drain cooling system and tighten drain plug.
- 3) Remove intercooler referring to "INTERCOOLER" in Section 6E3.
- 4) Remove intercooler bracket (1) and vacuum pipe (2).
- 5) Remove thermostat cap (1) from water outlet box (2).
- 6) Remove thermostat (3).

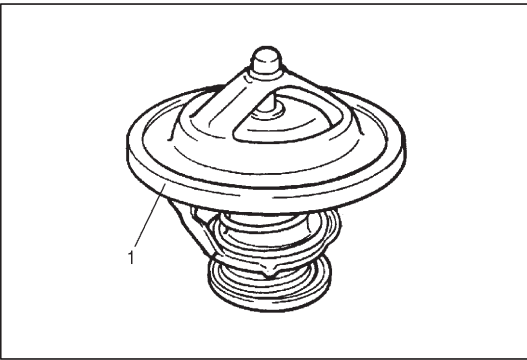
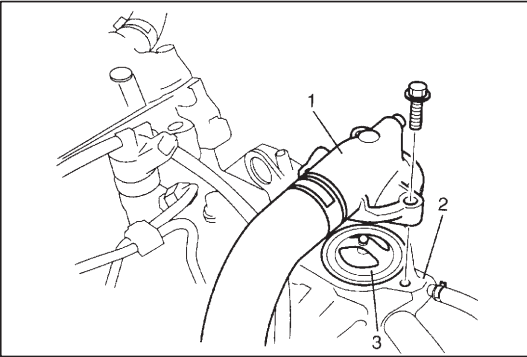

INSPECTION

- 1) Check to make sure that valve seat is free from foreign matters which would prevent valve from seating tight.
- 2) Check thermostat seal (1) for breakage, deterioration or any other damage.

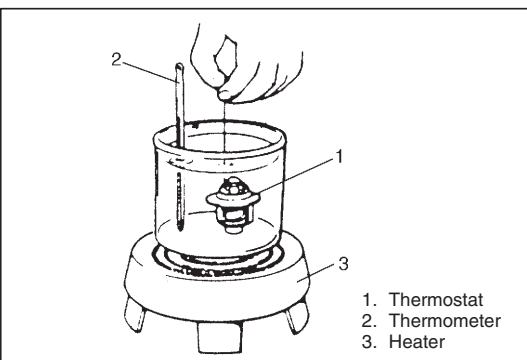

- 3) Check thermostatic movement of wax pellet as follows:
 - a) Immerse thermostat in water, and heat water gradually.
 - b) Check that valve starts to open at specific temperature.
 - c) If valve starts to open at a temperature substantially below or above specific temperature, thermostat unit should be replaced with a new one. Such a unit, if reused, will bring about overcooling or overheating tendency.

INSTALLATION

Reverse removal procedures.

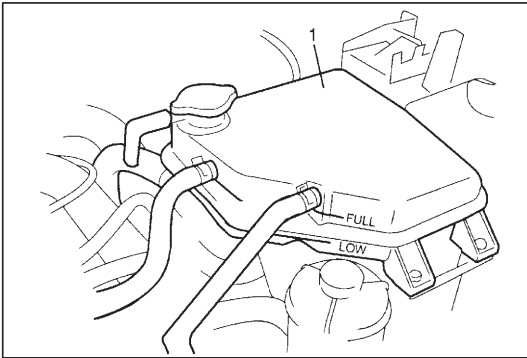

RADIATOR

REMOVAL

- 1) Disconnect negative cable at battery.
- 2) Drain cooling system by loosening drain plug of radiator.
- 3) Remove degassing tank (1) and its bracket.

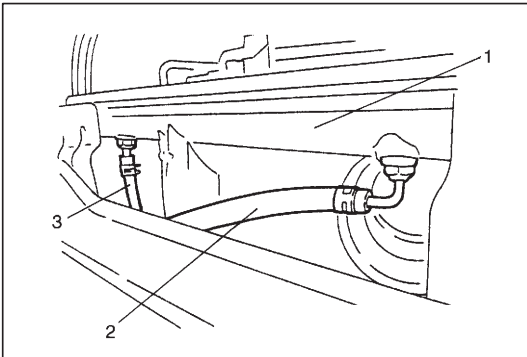

- 4) When servicing A/T vehicle, place oil pan under radiator (1) and disconnect A/T fluid hoses (2), (3) from radiator.

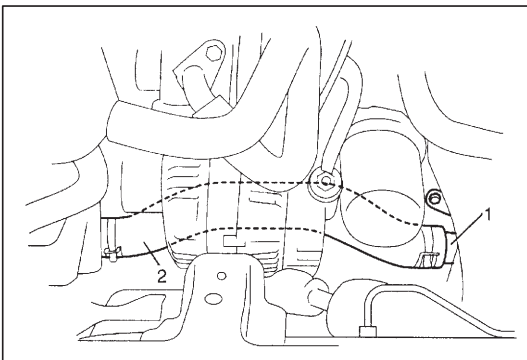

- 5) Detach water outlet pipe (1) from engine mounting bracket and disconnect radiator outlet hose (2) from radiator.

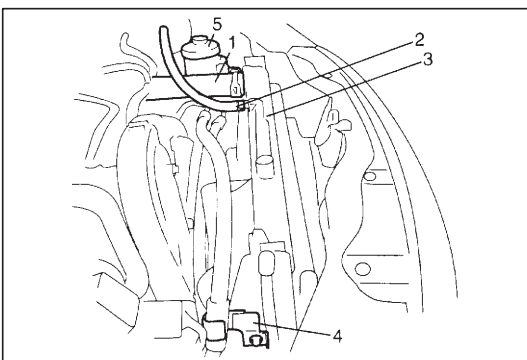

- 6) Disconnect radiator inlet hose (1) and degassing tank hose (2) from radiator (3).
- 7) Remove P/S high pressure hose clamp (4) and detach P/S fluid reservoir (5).

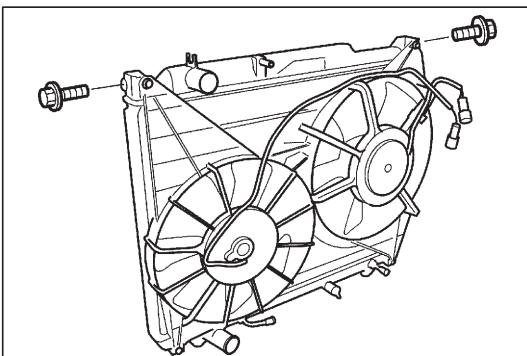

- 8) Disconnect radiator fan motor couplers and remove radiator with radiator fan motor assembly.
- 9) Remove radiator fan motor assembly from radiator.

INSPECTION

Check radiator for leakage or damage. Straighten bent fins, if any.

CLEANING

Clean frontal area of radiator cores.

INSTALLATION

Reverse removal procedures, noting the followings.

- Refill cooling system with proper coolant referring to “COOLANT” and steps 8) to 10) of “COOLING SYSTEM FLUSH AND REFILL” in this section.
- After installation, check each joint for leakage.
- With A/T vehicle, check A/T fluid level, referring to Section 7B1.

RADIATOR FAN RELAY

INSPECTION

Refer to “RADIATOR FAN CONTROL SYSTEM” in Section 6E3.

WATER PUMP

REMOVAL

- 1) Disconnect negative cable at battery.
- 2) Drain cooling system by loosening drain plug of radiator.
- 3) Remove timing belt referring to "TIMING BELT AND BELT TENSIONER" in Section 6A3.

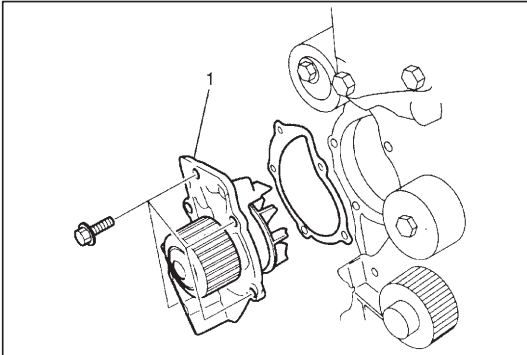

- 4) Remove water pump assembly (1).

CAUTION:

Do not disassemble water pump.

If any repair is required on pump, replace it as assembly.

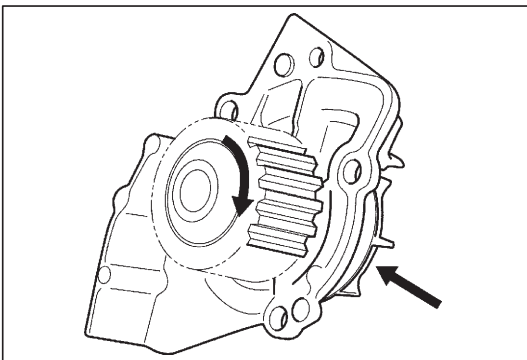

INSPECTION

- Rotate water pump by hand to check for smooth operation. If pump does not rotate smoothly or makes abnormal noise, replace it.
- Inspect water pump impeller for damage. Replace as necessary.

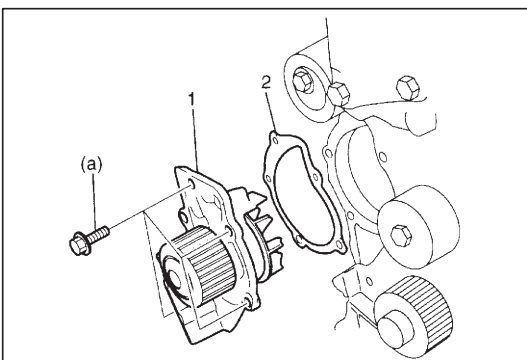

INSTALLATION

- 1) Install new pump gasket (2) to water pump (1).
- 2) Install water pump to cylinder block.

Tightening torque

Water pump bolt (a): 15 N·m (1.5 kg-m, 11.0 lb-ft)

- 3) Install timing belt and timing belt covers referring to "TIMING BELT AND BELT TENSIONER" in Section 6A3.
- 4) Connect negative cable at battery.
- 5) Fill coolant.
- 6) After installation, check each part for leakage.

REQUIRED SERVICE MATERIALS

MATERIALS	USE
Ethylene glycol base coolant (Anti-freeze/Anti-corrosion coolant)	Engine cooling system for improving cooling efficiency and for protection against rusting.

SECTION 6C

ENGINE FUEL

CAUTION:

Be sure to read "Precaution" in Section 6E before disconnecting fuel line or removing fuel system part(s). Failure to follow "Precaution" could result in unneeded fuel system repairs.

NOTE:

For the descriptions (items) not found in this section, refer to the same section of the Service Manual mentioned in FOREWORD of this manual.

CONTENTS

GENERAL DESCRIPTION	6C-1	Fuel Pump	6C-4
Fuel System	6C-1	Injection Pump	6C-4
ON-VEHICLE SERVICE	6C-2	2-way Check Valve	6C-5
Water Draining of Fuel System	6C-2	Fuel Tank	6C-5
Air Bleeding of Fuel System	6C-2	Fuel Level Gauge	6C-7
Fuel Filter Element	6C-2	Fuel Heater	6C-7

6C

GENERAL DESCRIPTION**FUEL SYSTEM**

The main components of the fuel system are fuel tank, fuel pump, high pressure fuel pump, fuel filter and fuel level gauge and it includes three lines and fuel feed line, fuel return line.

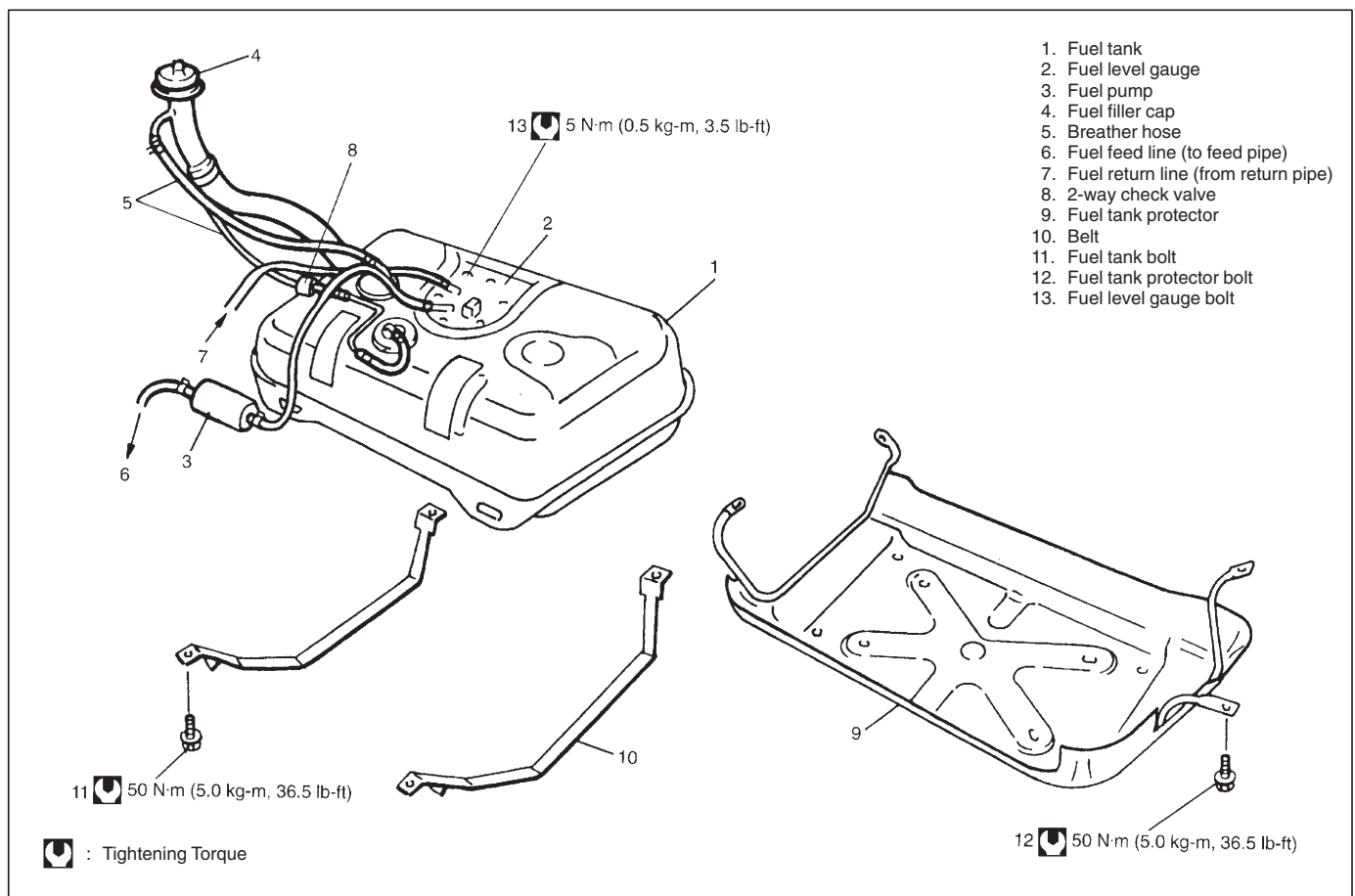

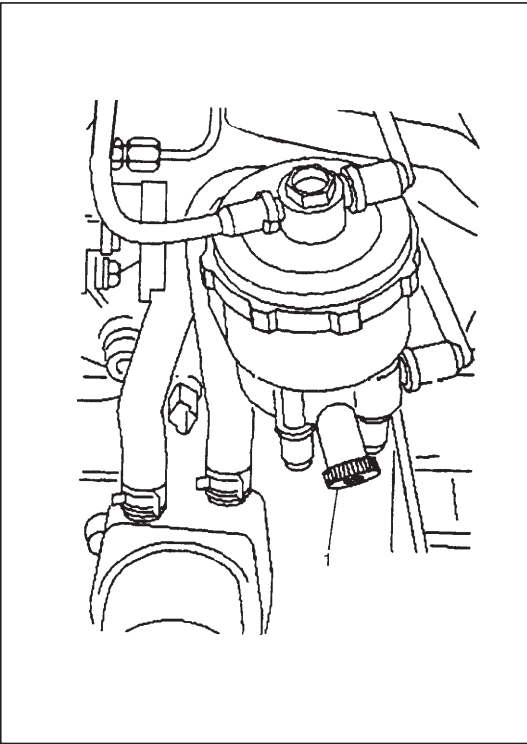

ON-VEHICLE SERVICE

WATER DRAINING OF FUEL FILTER

- 1) Loose bleed screw (1).
- 2) Drain water.
- 3) Tighten bleed screw.
- 4) Check for fuel leakage.

AIR BLEEDING OF FUEL SYSTEM

Air bleeding must be carried out when fuel system has been disassembled or when vehicle ran out of fuel.

Turn ignition switch ON to operate fuel pump and after about 5 seconds turn it OFF. Repeat this 6 times and then check engine starts.

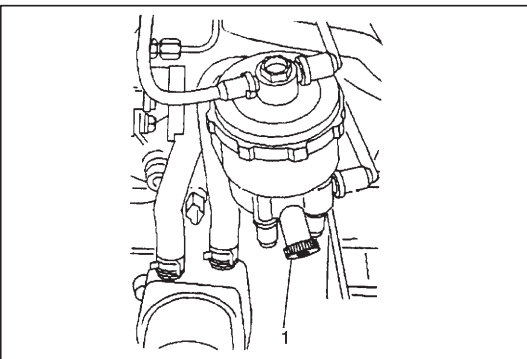

FUEL FILTER ELEMENT

REMOVAL

- 1) Disconnect negative cable at battery.
- 2) Loosen bleed screw (1) and drain fuel.

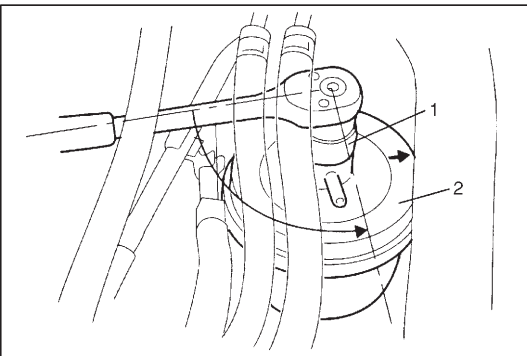

- 3) Turn cover (2) a quarter using a 22 mm socket (1).

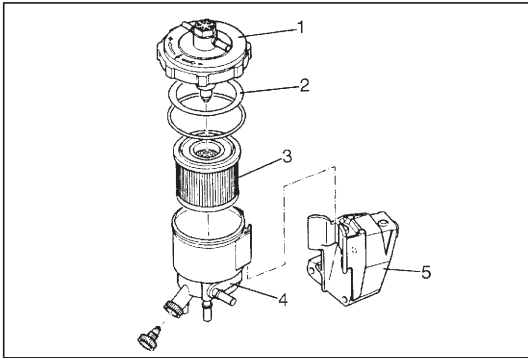

- 4) Remove cover (1), corrugated washer (2) and fuel filter element (3).
- 5) Remove fuel filter (4) from bracket (5) by unclipping and lifting fuel filter.
- 6) Clean fuel filter.

CAUTION:

Do not use compressed air to fuel filter and its element.

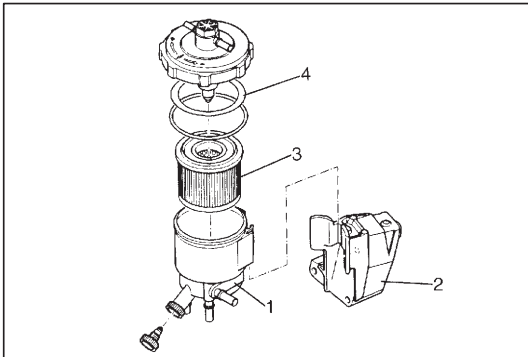
**INSTALLATION**

- 1) Install fuel filter (1) to bracket (2).
- 2) Set fuel filter element (3) and position it correctly.
- 3) Set corrugated washer (4) on fuel filter.

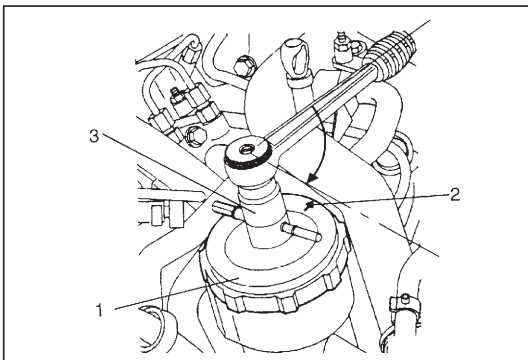

- 4) Set cover (1) so that arrow (2) on it is directed toward dash panel.
- 5) Tighten cover (1) a quarter turn using a 22 mm socket (3).

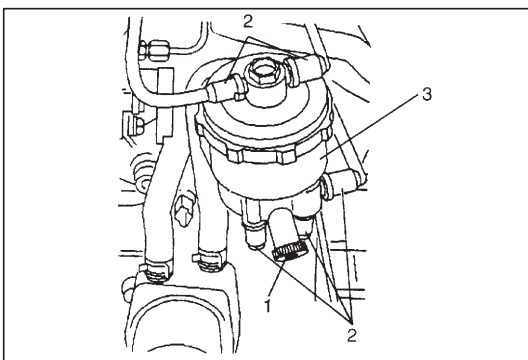

- 6) Connect fuel hoses (2) to fuel filter assembly (3).
- 7) Tighten bleed screw (1).
- 8) Connect negative cable at battery.
- 9) Bleed air in system referring to "AIR BLEEDING OF FUEL SYSTEM" in this section.
- 10) Start engine and check that there are no fuel leaks.

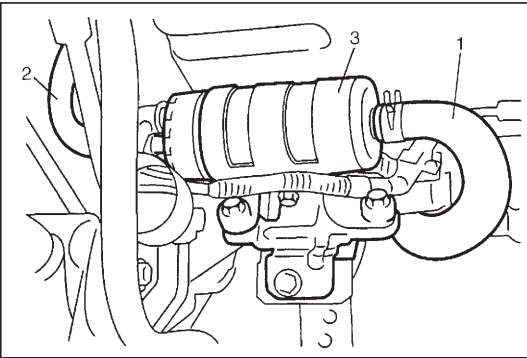

FUEL PUMP

REMOVAL

- 1) Remove fuel filler cap to release fuel pressure in fuel feed line.
- 2) Disconnect negative cable at battery.
- 3) Hoist vehicle.
- 4) Disconnect fuel pump wire harness.
- 5) Disconnect inlet hose (1) and outlet hose (2).
- 6) Remove fuel pump (3).



INSPECTION

Measure resistance between terminals “+” and “-” of pump. If found defective, replace.

Fuel pump resistance: About 2.1 Ω

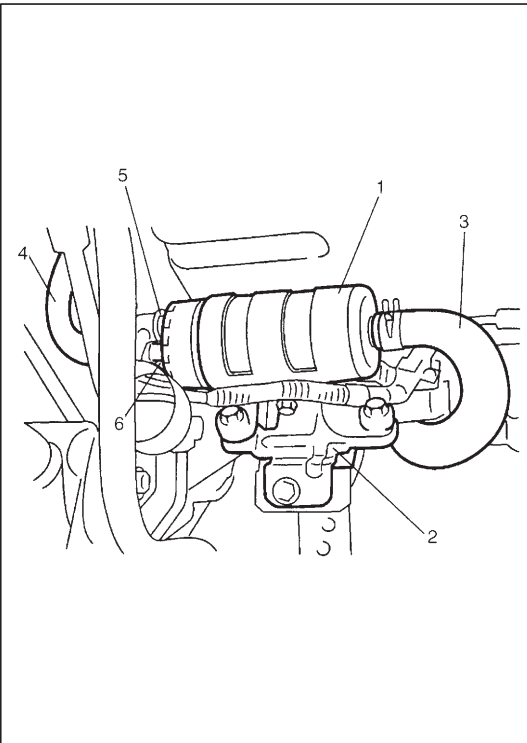

INSTALLATION

- 1) Install fuel pump (1) with its bracket (2) to chassis frame.
- 2) Connect inlet hose (3) and outlet hose (4).
- 3) Connect “PNK/BLK” wire terminal (5) and “BLK” wire terminal (6) to pump with nuts securely as shown in the left figure.
- 4) Lower hoist.
- 5) Connect negative cable at battery.
- 6) Install fuel filler cap.
- 7) Bleed air in system referring to “AIR BLEEDING OF FUEL SYSTEM” in this section.
- 8) Start engine and check that there are no fuel leaks.

INJECTION PUMP

For removal and installation, refer to “INJECTION PUMP” in Section 6E3.

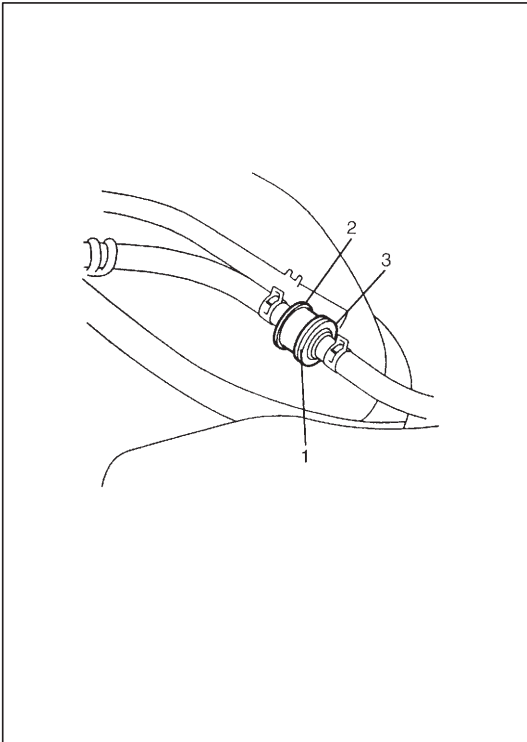

2-WAY CHECK VALVE (TANK PRESSURE CONTROL VALVE)

INSPECTION

- 1) Air should pass through 2-way check valve (1) smoothly from fuel tank side (Black side (2) of 2-way check valve) to Orange side (3) when blown hard.
- 2) From Orange side, even when blown softly, air should come out of Black side.
- 3) If air doesn't pass through valve in step 1) or hard blow is required in step 2), replace 2-way check valve.

WARNING:

DO NOT SUCK air through 2-way check valve.
Fuel vapor inside the valve is harmful.

FUEL TANK

REMOVAL

CAUTION:

This work must not be done when engine is hot. If done so, it may cause adverse effect to catalyst.

- 1) Disconnect negative cable at battery.
- 2) Remove fuel filter cap.
- 3) Insert hose of a hand operated pump into fuel filler hose (1) and drain fuel in space "A" in the figure (drain fuel through it till fuel stops).

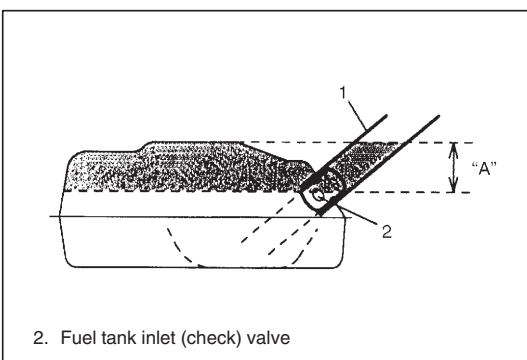

2. Fuel tank inlet (check valve)

CAUTION:

Do not force hose of a hand operated pump into fuel tank.
Doing so can damage inlet valve.

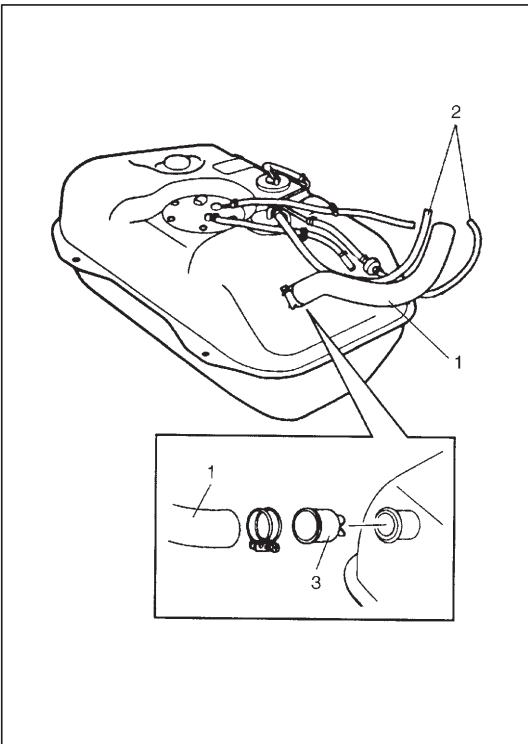

- 4) Disconnect filler hose (1) from fuel tank and breather hoses (2) from fuel filler neck.
- 5) Remove fuel tank inlet valve (3).
Use care not to damage inlet valve when removing.
- 6) Drain fuel tank by pumping fuel out through fuel tank filler.
Use hand operated pump device to drain fuel tank.

CAUTION:

Never drain or store fuel in an open container due to possibility of fire or explosion.

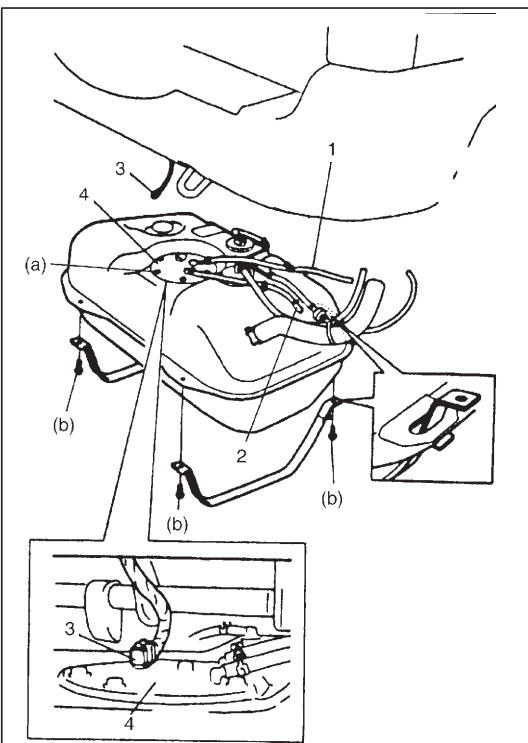

- 7) Disconnect fuel pump inlet hose (1) from fuel pump and fuel return hose (2) from pipes.
- 8) Remove fuel tank protector (if equipped) from vehicle.
- 9) Lower fuel tank gradually while holding it horizontally and pull out coupler (3) at fuel level gauge (4).

INSTALLATION

For installation, reverse removal procedure described above.
Tighten each bolt to specified torque.

Tightening Torque

Fuel level gauge bolt (a): 5.0 N·m (0.5 kg-m, 3.5 lb-ft)

Fuel tank bolt (b): 50 N·m (5.0 kg-m, 36.0 lb-ft)

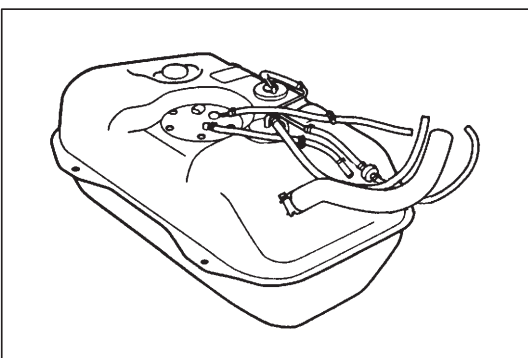
**INSPECTION**

After removing fuel tank, check hoses and pipes connected to fuel tank for leaks, loose connections, deterioration or damage. Also check fuel level gauge gaskets for leaks, visually inspect fuel tank for leaks and damage.

Replace any damaged or malfunctioning parts.

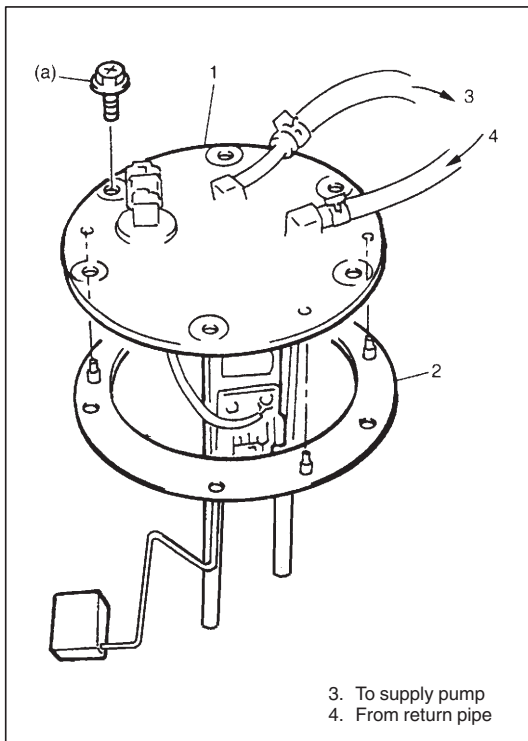

FUEL LEVEL GAUGE

REMOVAL

- 1) Remove fuel tank. Refer to "FUEL TANK" in this section.
- 2) Remove fuel level gauge (1) from fuel tank.

INSPECTION

Check fuel level gauge (1) for evidence of dirt and contamination. If present, clean and check for presence of dirt in fuel tank.

INSTALLATION

Reverse removal procedure for installation noting the followings.

- Use new gasket (2).
- Tighten fuel level gauge bolts to specified torque.

Tightening Torque

Fuel level gauge bolt (a): 5.0 N·m (0.5 kg·m, 3.5 lb·ft)

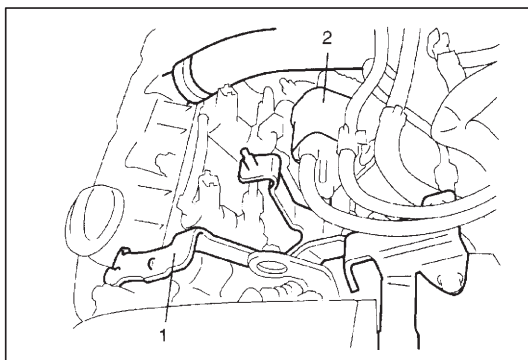

FUEL HEATER

REMOVAL

- 1) Disconnect negative cable at battery.
- 2) Disconnect fuel heater connector.
- 3) Disconnect fuel feed hose and inlet fuel hose from fuel heater.
- 4) Remove bracket (1) with fuel heater (2).

INSPECTION

Inspect for damage or deformation. If defective, replace.

INSTALLATION

Reverse removal procedure for installation.

SECTION 6E3

ENGINE AND EMISSION CONTROL SYSTEM (RHZ ENGINE)

WARNING:

For vehicles equipped with Supplemental Restraint (Air Bag) System:

- Service on and around the air bag system components or wiring must be performed only by an authorized SUZUKI dealer. Refer to “Air Bag System Components and Wiring Location View” under “General Description” in air bag system section in order to confirm whether you are performing service on or near the air bag system components or wiring. Please observe all WARNINGS and “Service Precautions” under “On-Vehicle Service” in air bag system section before performing service on or around the air bag system components or wiring. Failure to follow WARNINGS could result in unintentional activation of the system or could render the system inoperative. Either of these two conditions may result in severe injury.
- Technical service work must be started at least 90 seconds after the ignition switch is turned to the “LOCK” position and the negative cable is disconnected from the battery. Otherwise, the system may be activated by reserve energy in the Sensing and Diagnostic Module (SDM).

6E3

CONTENTS

GENERAL DESCRIPTION	6E3- 3	Fuel Heater	6E3-23
System Diagram	6E3- 3	Fuel Injector	6E3-24
Air Intake System	6E3- 4	Common Rail (High Pressure Fuel Injection Rail) ...	6E3-27
Fuel Delivery System	6E3- 5	Injection Pump	6E3-30
Electronic Control System	6E3- 6	Electronic Control System	6E3-32
System Location Diagram	6E3- 6	Engine Control Module (ECM)	6E3-32
System Wiring Diagram	6E3- 7	Mass Air Flow Sensor (MAF Sensor) ..	6E3-34
ON-VEHICLE SERVICE	6E3-11	Throttle Position Sensor (TP Sensor) (Accelerator Stroke Sensor)	6E3-35
Accelerator Cable Adjustment	6E3-11	Fuel Temperature Sensor Assembly ...	6E3-36
Idle Speed Inspection	6E3-11	Fuel (Rail) Pressure Sensor	6E3-38
Air Intake System	6E3-12	Engine Coolant Temperature Sensor (ECT Sensor)	6E3-39
Vacuum Hose Routing Diagram	6E3-12	VSS	6E3-40
Intercooler	6E3-13	Camshaft Position Sensor (CMP Sensor)	6E3-40
Throttle Valve Assembly	6E3-14	Crankshaft Position Sensor (Engine Speed Sensor)	6E3-41
EGR Throttle Solenoid Valve	6E3-15	Intake Air Pressure Sensor (Manifold Absolute Pressure Sensor)	6E3-42
Vacuum Pump	6E3-15	Radiator Fan Control System	6E3-43
Turbocharger	6E3-16	Double Relay	6E3-46
Boost Pressure Regulator Solenoid Valve	6E3-18	Pre Post Heating Relay (Control Unit)	6E3-47
Glow Plug	6E3-19		
Fuel Delivery System	6E3-20		
Precautions	6E3-20		
Low Pressure Fuel Supply System	6E3-22		
Fuel Pump	6E3-23		

EGR System 6E3-48
Vacuum Hose 6E3-48
EGR Valve 6E3-48
EGR Solenoid Valve 6E3-49

TIGHTENING TORQUE
SPECIFICATIONS 6E3-50
SPECIAL TOOLS 6E3-51

GENERAL DESCRIPTION

SYSTEM DIAGRAM

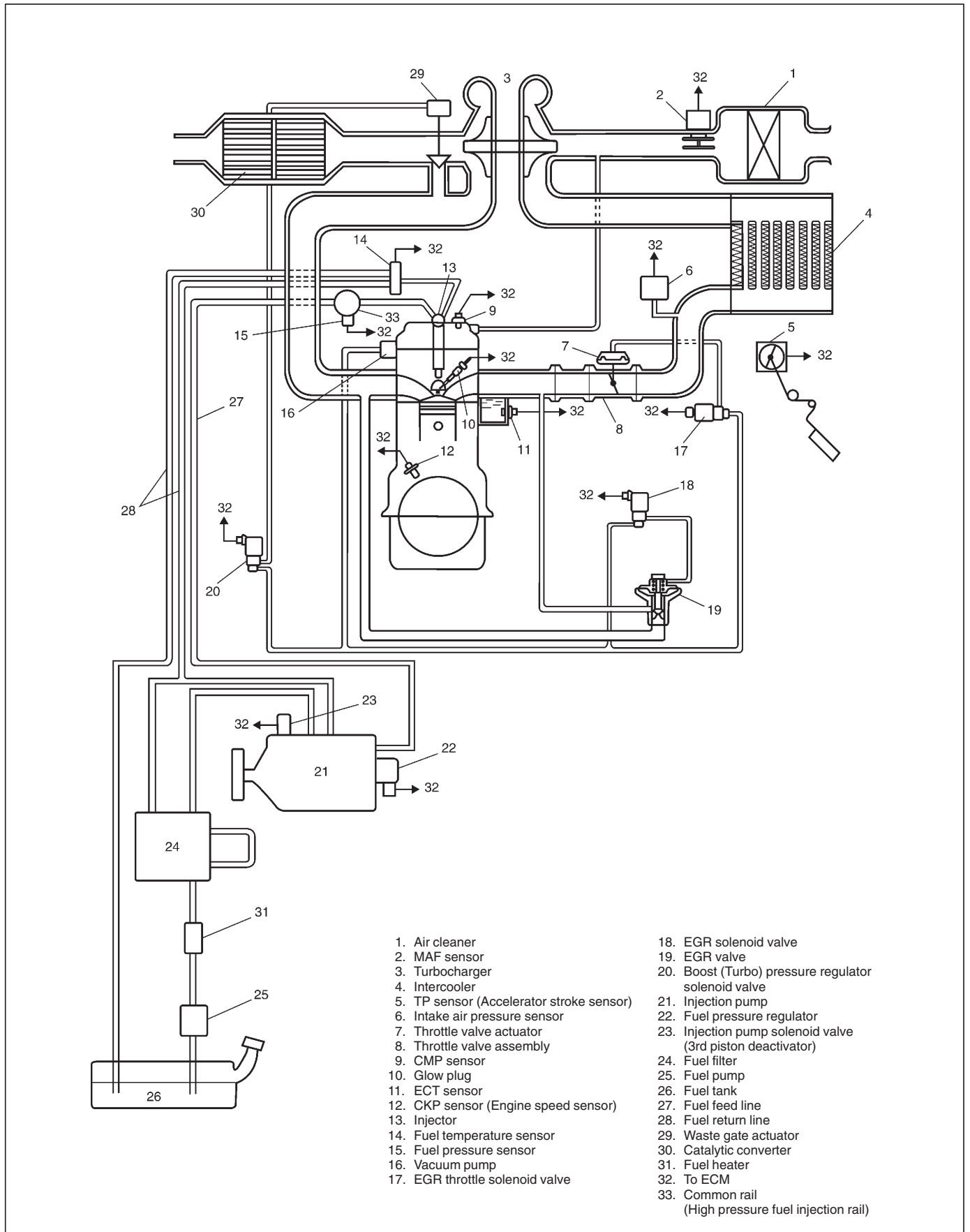

AIR INTAKE SYSTEM

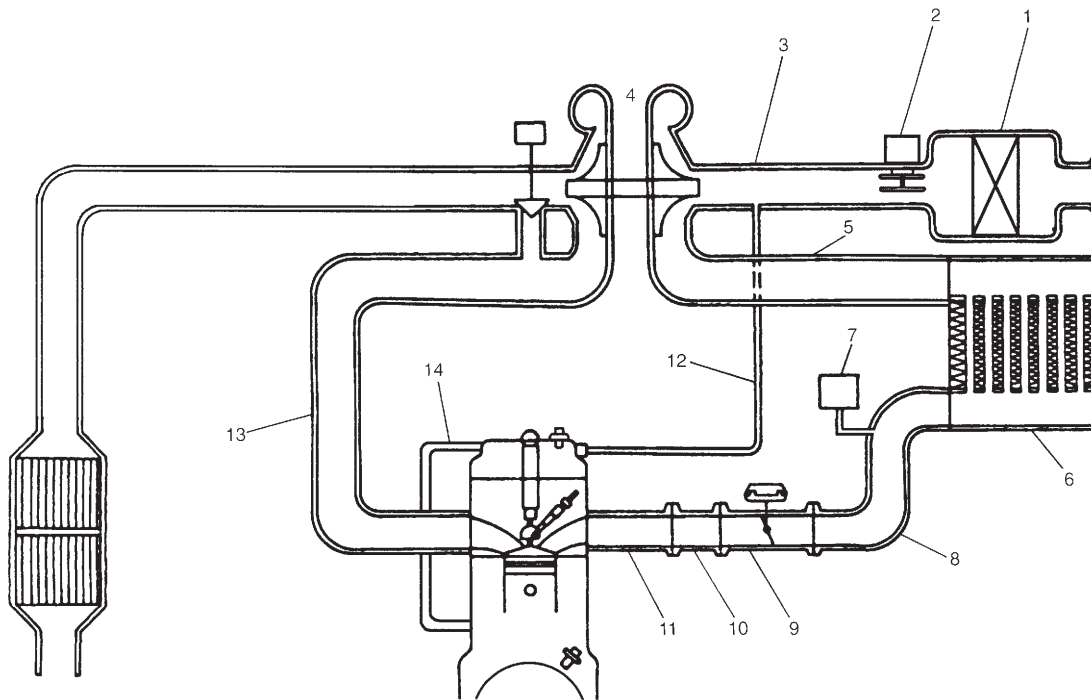

1. Air cleaner
2. MAF sensor
3. Air cleaner outlet hose
4. Turbocharger
5. Intercooler inlet hose
6. Intercooler
7. Intake air pressure sensor
8. Intercooler outlet hose
9. Throttle valve assembly
10. Elbow air divider
11. Intake manifold
12. Breather hose
13. Exhaust manifold
14. PCV hose

FUEL DELIVERY SYSTEM

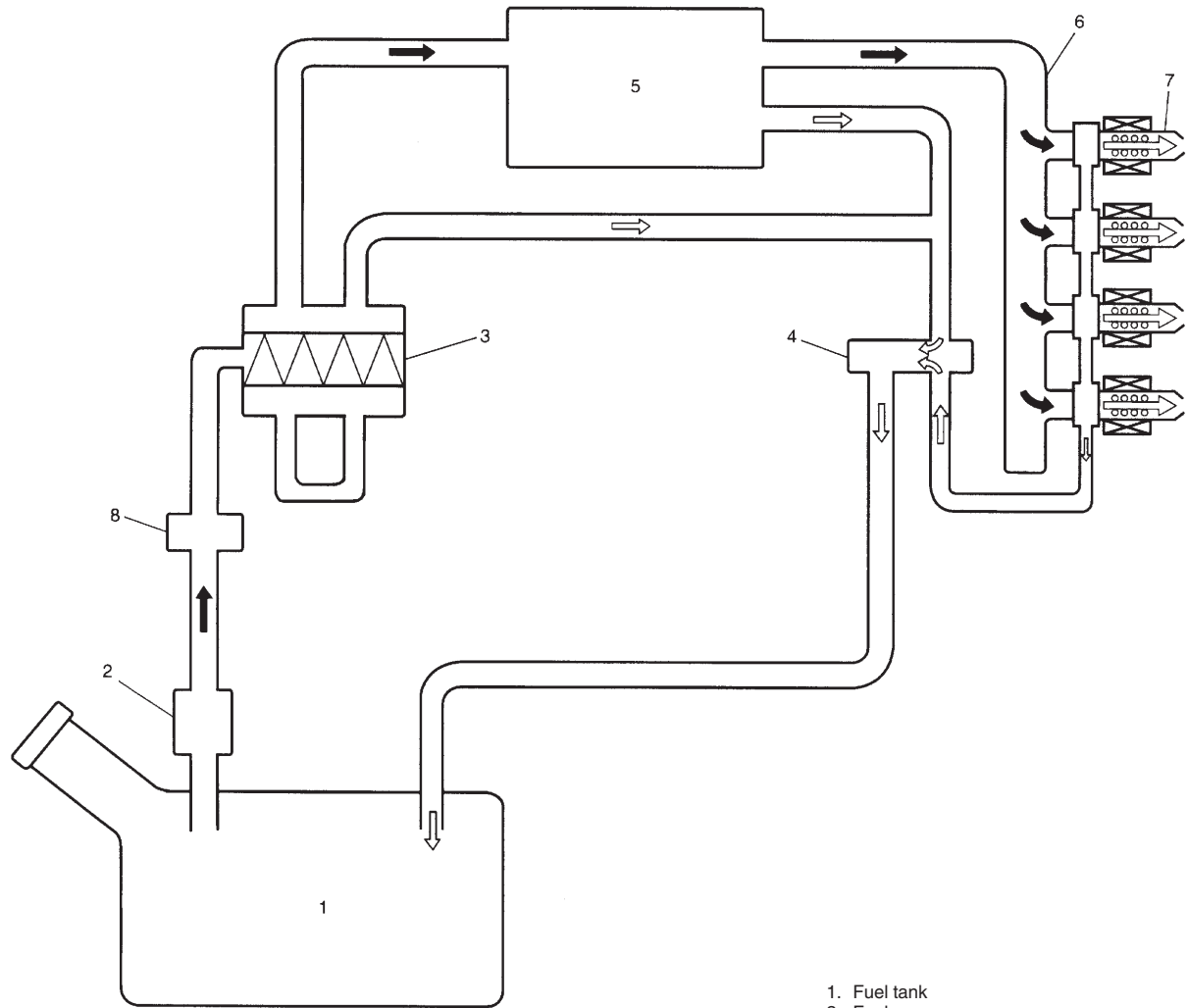

1. Fuel tank
2. Fuel pump
3. Fuel filter
4. Fuel temperature sensor
5. Injection pump
6. Common rail
(High pressure fuel injection rail)
7. Injector
8. Fuel heater

➡ : Fuel feed line

↩ : Fuel return line

ELECTRONIC CONTROL SYSTEM SYSTEM LOCATION DIAGRAM

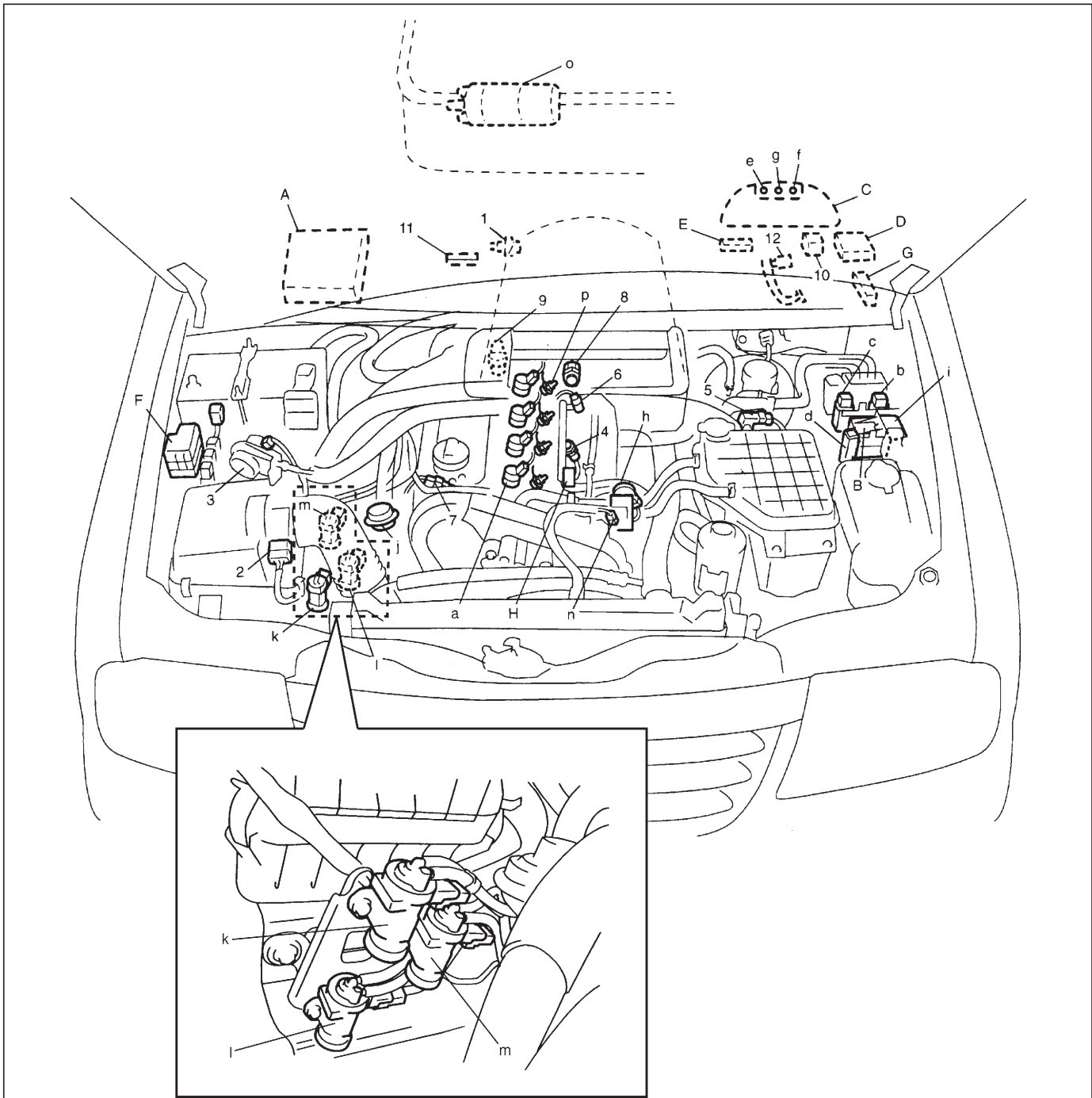

INFORMATION SENSORS

- 1. VSS (Installed on transfer)
- 2. MAF sensor (built-in intake air temp. sensor)
- 3. Accelerator stroke sensor
- 4. Fuel (rail) pressure sensor
- 5. Intake air pressure sensor
- 6. Fuel temperature sensor
- 7. CMP sensor
- 8. ECT sensor
- 9. CKP sensor (Engine speed sensor)
- 10. Immobilizer control module
- 11. A/C control module
- 12. Brake lamp switch

CONTROLLED DEVICES

- a: Injector
- b: Radiator fan relay 1 (High/Low)
- c: Radiator fan relay 2 (High)
- d: Radiator fan relay 3 (Low)
- e: Engine coolant temperature warning lamp
- f: Malfunction indicator lamp
- g: Glow indicator lamp
- h: Fuel pressure regulator
- i: Double relay
- j: EGR valve
- k: EGR solenoid valve
- l: Boost (Turbo) pressure regulator solenoid valve
- m: EGR throttle solenoid valve
- n: Injection pump solenoid valve (3rd piston deactivator)
- o: Fuel pump
- p: Glow plug

OTHERS

- A: ECM
- B: Pre post heating relay (control unit)
- C: Combination meter
- D: TCM
- E: Data link connector
- F: Main fuse box
- G: Fuse box
- H: Fuel heater

SYSTEM WIRING DIAGRAM

For Vehicle Equipped with Single-Connector ECM

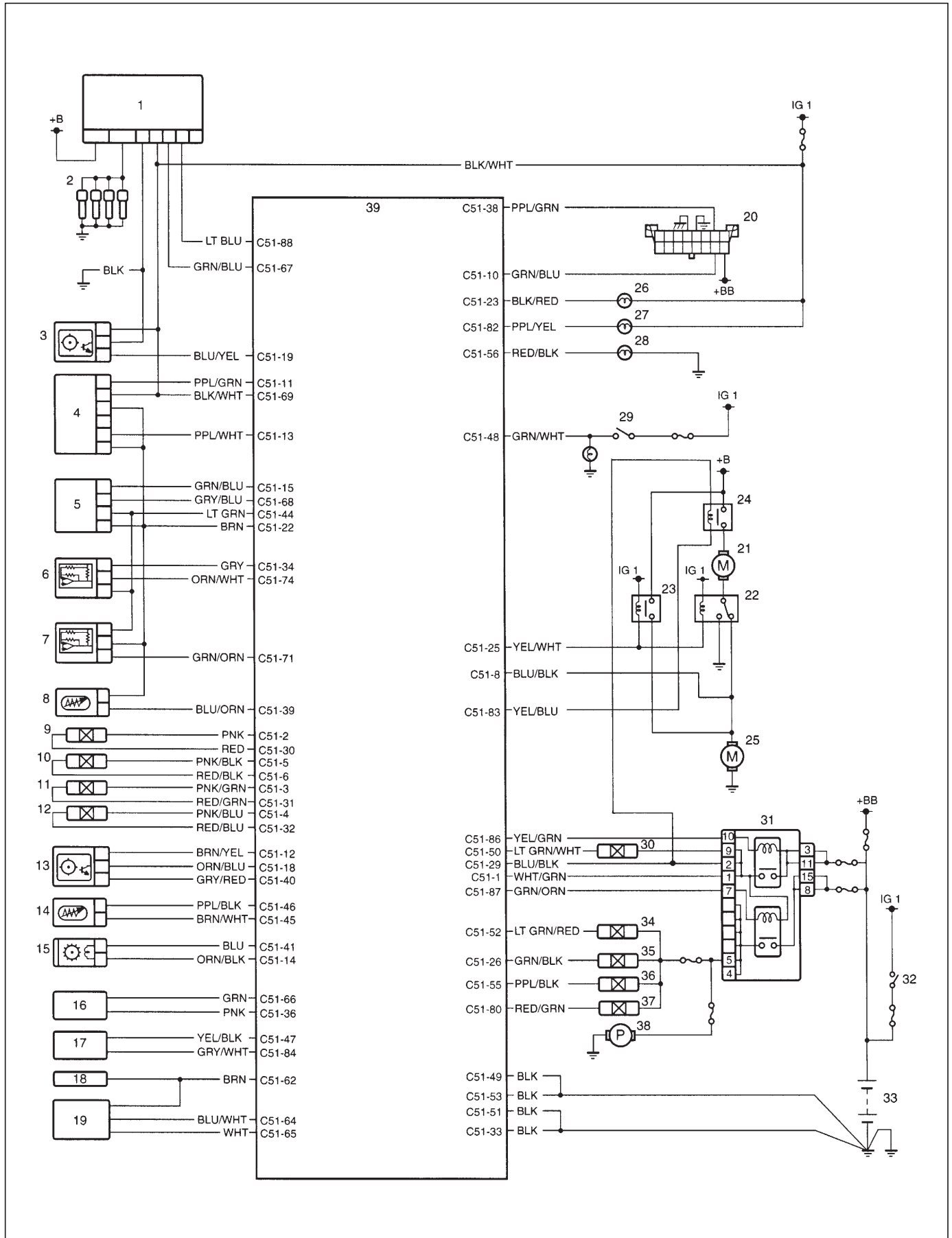

ECM CONNECTOR (TERMINAL ARRANGEMENT VIEWED FROM HARNESS SIDE)

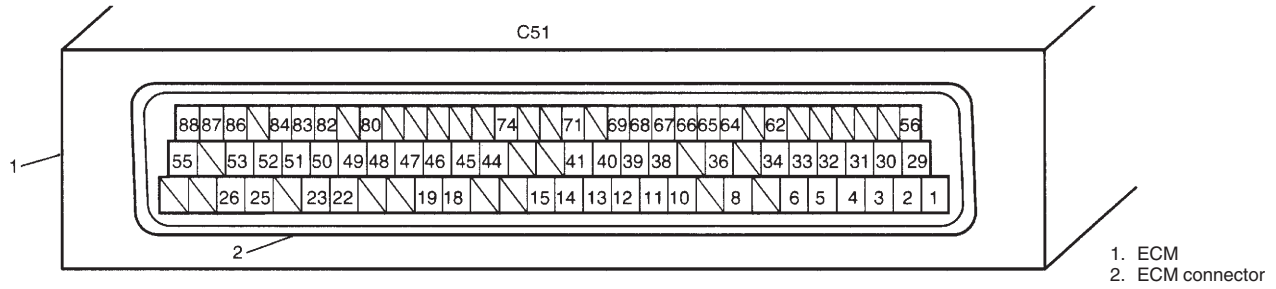

- | | | |
|--|--|--|
| 1. Pre post heating relay (control unit) | 14. Engine coolant temperature sensor | 28. Glow indicator lamp |
| 2. Glow plugs | 15. Crankshaft position sensor (Engine speed sensor) | 29. Brake lamp switch |
| 3. Vehicle speed sensor | 16. Immobilizer control module | 30. Fuel pressure regulator |
| 4. Mass air flow sensor (built-in intake air temp. sensor) | 17. A/C control module | 31. Double relay |
| 5. Throttle position sensor (Accelerator stroke sensor) | 18. Combination meter | 32. Ignition switch |
| 6. Fuel (rail) pressure sensor | 19. Transmission control module (TCM) | 33. Battery |
| 7. Intake air pressure sensor (MAP sensor) | 20. Data link connector | 34. EGR solenoid valve |
| 8. Fuel temperature sensor | 21. Radiator fan motor 1 (Left side) | 35. Boost (Turbo) pressure regulator solenoid valve |
| 9. Fuel injector No.1 | 22. Radiator fan relay 1 (High/Low) | 36. EGR throttle solenoid valve |
| 10. Fuel injector No.2 | 23. Radiator fan relay 2 (High) | 37. Injection pump solenoid valve (3rd piston deactivator) |
| 11. Fuel injector No.3 | 24. Radiator fan relay 3 (Low) | 38. Fuel pump |
| 12. Fuel injector No.4 | 25. Radiator fan motor 2 (Right side) | 39. Engine control module (ECM) |
| 13. Camshaft position sensor | 26. Engine coolant temperature warning lamp | |
| | 27. Malfunction indicator lamp | |

TERMINAL	CIRCUIT	TERMINAL	CIRCUIT	TERMINAL	CIRCUIT
C51-1	Double relay (Main relay)	C51-31	Fuel injector No.3 (-)	C51-61	-
C51-2	Fuel injector No.1 (+)	C51-32	Fuel injector No.4 (-)	C51-62	Engine speed signal (Combination meter)
C51-3	Fuel injector No.3 (+)	C51-33	Ground	C51-63	-
C51-4	Fuel injector No.4 (+)	C51-34	Ground for fuel pressure sensor	C51-64	Throttle position signal (A/T)
C51-5	Fuel injector No.2 (+)	C51-35	-	C51-65	Engine torque signal (A/T)
C51-6	Fuel injector No.2 (-)	C51-36	Immobilizer control module signal	C51-66	Immobilizer control module wake-up signal
C51-7	-	C51-37	-	C51-67	Pre heating diagnostic
C51-8	Radiator fan state	C51-38	Data link connector (K-line)	C51-68	Throttle position sensor
C51-9	-	C51-39	Fuel temperature sensor	C51-69	Power source for mass air flow sensor (Power source after ignition on)
C51-10	Data link connector 12 V (L-line)	C51-40	Ground for camshaft position sensor	C51-70	-
C51-11	Intake air temperature	C51-41	Crankshaft position (Engine speed) sensor (+)	C51-71	Intake air pressure sensor
C51-12	Camshaft position sensor (+)	C51-42	-	C51-72	-
C51-13	Mass air flow sensor	C51-43	-	C51-73	-
C51-14	Crankshaft position (Engine speed) sensor (-)	C51-44	Sensor supply 5 V	C51-74	Fuel (rail) pressure sensor
C51-15	Throttle position sensor (Accelerator stroke sensor)	C51-45	Engine coolant temperature sensor signal	C51-75	-
C51-16	-	C51-46	Engine coolant temperature sensor	C51-76	-
C51-17	-	C51-47	A/C control module	C51-77	-
C51-18	Camshaft position sensor	C51-48	Brake lamp switch	C51-78	-
C51-19	Vehicle speed sensor	C51-49	Ground	C51-79	-
C51-20	-	C51-50	Fuel pressure regulator	C51-80	Injection pump solenoid valve (3rd piston deactivator)
C51-21	-	C51-51	Ground	C51-81	-
C51-22	Sensor ground	C51-52	EGR solenoid valve	C51-82	Malfunction indicator lamp
C51-23	Engine coolant temp. warning lamp	C51-53	Ground	C51-83	Radiator fan relay (Low)
C51-24	-	C51-54	-	C51-84	A/C cut signal
C51-25	Radiator fan relay (High)	C51-55	EGR throttle solenoid valve	C51-85	-
C51-26	Boost (Turbo) pressure regulator solenoid valve	C51-56	Glow indicator lamp	C51-86	Double relay (Main relay)
C51-27	-	C51-57	-	C51-87	Double relay (fuel pump relay)
C51-28	-	C51-58	-	C51-88	Pre post heating relay
C51-29	Power source	C51-59	-		
C51-30	Fuel injector No.1 (-)	C51-60	-		

For Vehicle Equipped with Triple-Connector ECM

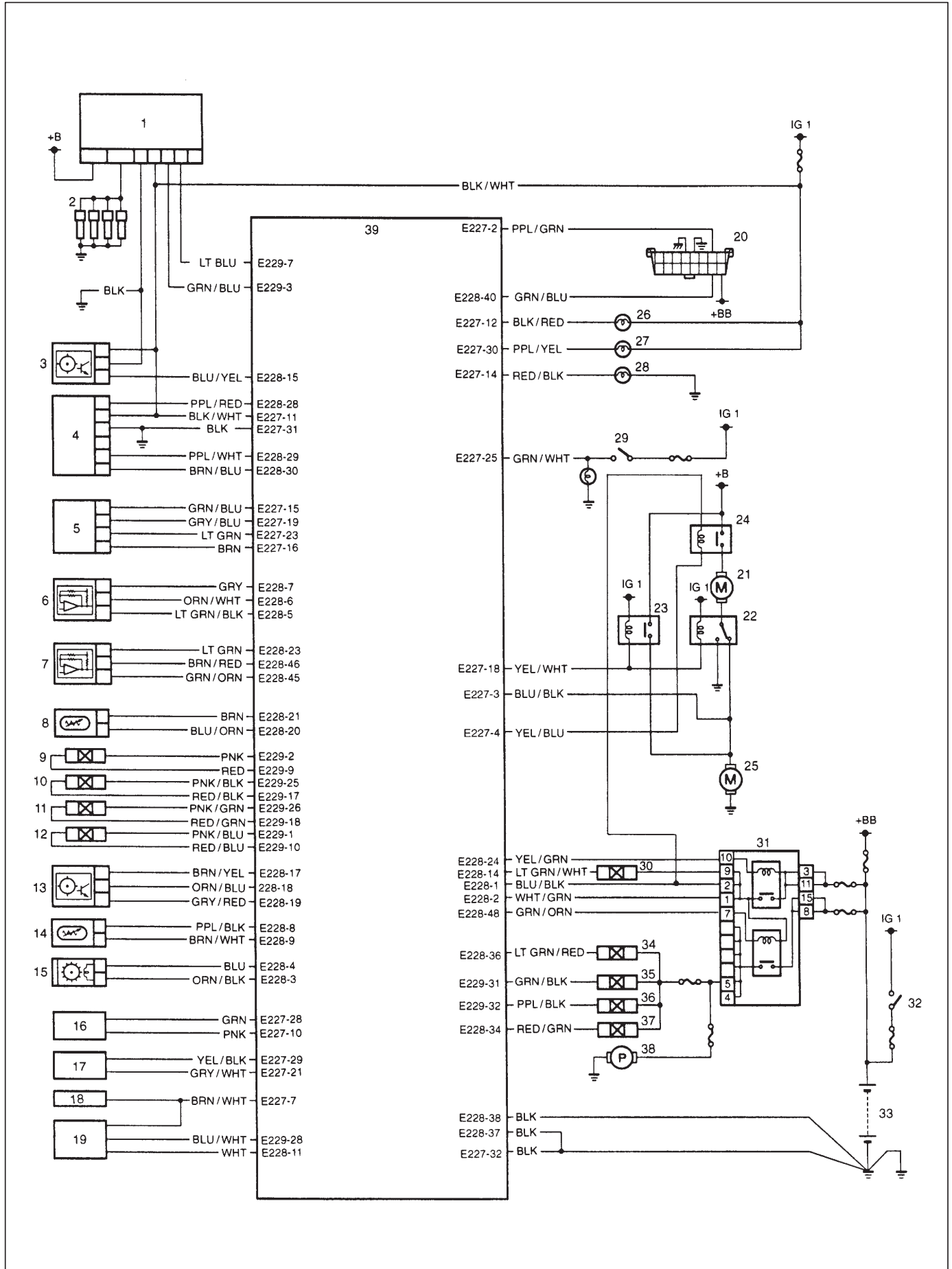

ECM CONNECTOR (TERMINAL ARRANGEMENT VIEWED FROM HARNESS SIDE)

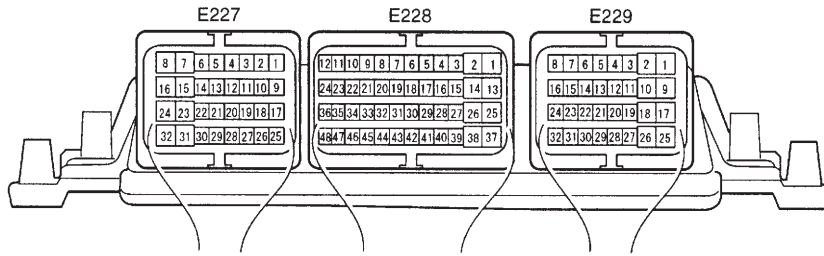

- | | | |
|--|--|--|
| 1. Pre post heating relay (control unit) | 14. Engine coolant temperature sensor | 28. Glow indicator lamp |
| 2. Glow plugs | 15. Crankshaft position sensor (Engine speed sensor) | 29. Brake lamp switch |
| 3. Vehicle speed sensor | 16. Immobilizer control module | 30. Fuel pressure regulator |
| 4. Mass air flow sensor (built-in intake air temp. sensor) | 17. A/C control module | 31. Double relay |
| 5. Throttle position sensor (Accelerator stroke sensor) | 18. Combination meter | 32. Ignition switch |
| 6. Fuel (rail) pressure sensor | 19. Transmission control module (TCM) | 33. Battery |
| 7. Intake air pressure sensor (MAP sensor) | 20. Data link connector | 34. EGR solenoid valve |
| 8. Fuel temperature sensor | 21. Radiator fan motor 1 (Left side) | 35. Boost (Turbo) pressure regulator solenoid valve |
| 9. Fuel injector No. 1 | 22. Radiator fan relay 1 (High/Low) | 36. EGR throttle solenoid valve |
| 10. Fuel injector No.2 | 23. Radiator fan relay 2 (High) | 37. Injection pump solenoid valve (3rd piston deactivator) |
| 11. Fuel injector No.3 | 24. Radiator fan relay 3 (Low) | 38. Fuel pump |
| 12. Fuel injector No.4 | 25. Radiator fan motor 2 (Right side) | 39. Engine control module (ECM) |
| 13. Camshaft position sensor | 26. Engine coolant temperature warning lamp | |
| | 27. Malfunction indicator lamp | |

TERMINAL	CURCUIT	TERMINAL	CURCUIT	TERMINAL	CURCUIT
E227	1	-	E228	7	Ground for fuel pressure sensor
	2	Data link connector (K-line)		8	Engine coolant temperature sensor (-)
	3	Radiator fan state		9	Engine coolant temperature sensor (+)
	4	Radiator fan relay (low)		10	-
	5	-		11	Engine torque signal (A/T)
	6	-		12	-
	7	Engine speed signal (Combination meter)		13	-
	8	-		14	Fuel pressure regulator
	9	-		15	Vehicle speed sensor
	10	Immobilizer control module signal		16	-
	11	Power supply for mass air flow sensor		17	Power supply for camshaft position sensor
	12	Engine coolant temperature warning lamp		18	Signal for camshaft position sensor
	13	-		19	Ground for camshaft position sensor
	14	Glow indicator lamp		20	Signal for fuel temperature sensor
	15	Throttle position sensor (+) (Accelerator stroke sensor)		21	Ground for fuel temperature sensor
	16	Sensor ground		22	-
	17	-		23	Power supply for intake air pressure sensor
	18	Radiator fan relay (high)		24	Double relay (Main relay)
	19	Throttle position sensor (-) (Accelerator stroke sensor)		25	-
	20	-		26	-
	21	Cut off signal for A/C control module		27	-
	22	-		28	Intake air temperature sensor
	23	5 V power supply output		29	Mass air flow sensor (+)
	24	-		30	Mass air flow sensor (-)
	25	Brake lamp switch		31	-
	26	-		32	-
	27	-		33	-
	28	Immobilizer control module wake-up signal		34	injection pump solenoid valve (3rd position deactivator)
	29	A/C control module signal		35	-
	30	Malfunction indicator lamp		36	ERG solenoid valve
	31	Ground for mass air flow sensor		37	Ground
	32	Ground		38	Ground
E228	1	Power source	39	-	
	2	Double relay (Main relay)	40	Data link connector 12 V (L-line)	
	3	Crankshaft position (Engine speed) sensor (-)	41	-	
	4	Crankshaft position (Engine speed) sensor (+)	42	-	
	5	Power supply for fuel pressure sensor	43	-	
	6	Signal for fuel pressure sensor	44	-	
E229	45	Signal for intake air pressure sensor	E229	45	Signal for intake air pressure sensor
	46	Ground for intake air pressure sensor		46	Ground for intake air pressure sensor
	47	-		47	-
	48	Double relay (Fuel pump relay)		48	Double relay (Fuel pump relay)
	1	Fuel injector No.4 (+)		1	Fuel injector No.4 (+)
	2	Fuel injector No.1 (+)		2	Fuel injector No.1 (+)
	3	Pre post heating diagnostic		3	Pre post heating diagnostic
	4	-		4	-
	5	-		5	-
	6	-		6	-
	7	Pre post heating relay		7	Pre post heating relay
	8	-		8	-
9	Fuel injector No.1 (-)	9	Fuel injector No.1 (-)		
10	Fuel injector No.4 (-)	10	Fuel injector No.4 (-)		
11	-	11	-		
12	-	12	-		
13	-	13	-		
14	-	14	-		
15	-	15	-		
16	-	16	-		
17	Fuel injector No.2 (-)	17	Fuel injector No.2 (-)		
18	Fuel injector No.3 (-)	18	Fuel injector No.3 (-)		
19	-	19	-		
20	-	20	-		
21	-	21	-		
22	-	22	-		
23	-	23	-		
24	-	24	-		
25	Fuel injector No.2 (+)	25	Fuel injector No.2 (+)		
26	Fuel injector No.3 (+)	26	Fuel injector No.3 (+)		
27	-	27	-		
28	Throttle position signal (A/T)	28	Throttle position signal (A/T)		
29	-	29	-		
30	-	30	-		
31	Boost (Turbo) pressure regulator solenoid valve	31	Boost (Turbo) pressure regulator solenoid valve		
32	ERG throttle solenoid valve	32	ERG throttle solenoid valve		

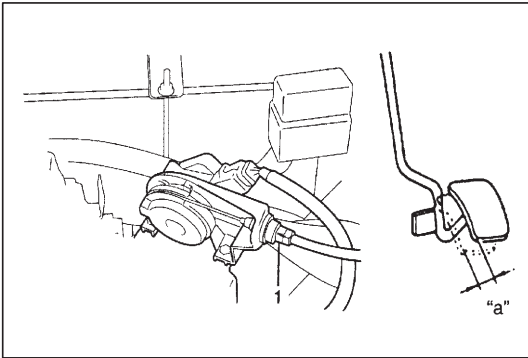

ON-VEHICLE SERVICE

ACCELERATOR CABLE ADJUSTMENT

- 1) Check accelerator pedal play which should be within following specification.

If measured value is out of specification, adjust it to specification with cable adjusting nut (1).

Pedal play "a": 2 – 7 mm (0.08 – 0.27 in.)

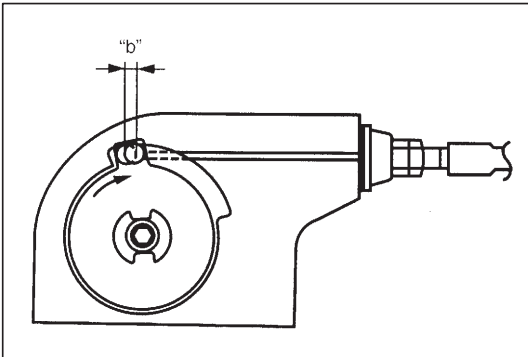

- 2) With accelerator pedal depressed fully, check clearance between throttle lever and lever stopper (throttle body) which should be within following specification.

**Clearance "b": 0.5 – 2.0 mm (0.02 – 0.07 in.)
(With pedal depressed fully)**

If measured value is out of specification, adjust it to specification by changing height of pedal stopper bolt.

IDLE SPEED INSPECTION

- 1) Shift transmission into Neutral (for M/T) or P range (for A/T).
- 2) Start engine and warm it up to normal operating temperature.
- 3) Turn all electrical loads off.
- 4) Using tachometer, verify that idle speed is within specification.

**Engine speed: 825 – 875 rpm (M/T)
795 – 845 rpm (A/T)**

- 5) Operate A/C and verify that engine speed is within specification.

Engine speed: 825 – 875 rpm (M/T or A/T)

- 6) If not, refer to troubleshooting "Improper engine idle" under "Engine Diagnosis Table" in following section.

- For vehicle equipped with single-connector ECM : Section 6
- For vehicle equipped with triple-connector ECM : Section 6-1

AIR INTAKE SYSTEM

VACUUM HOSE ROUTING DIAGRAM

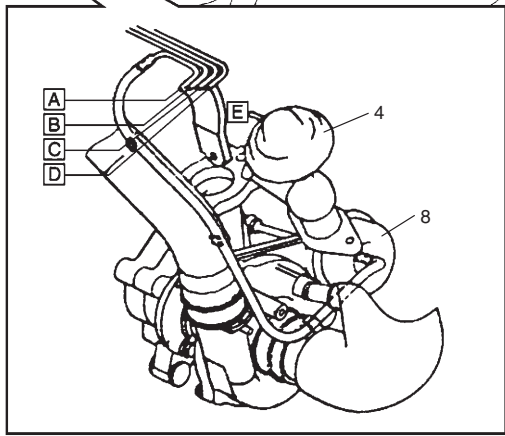
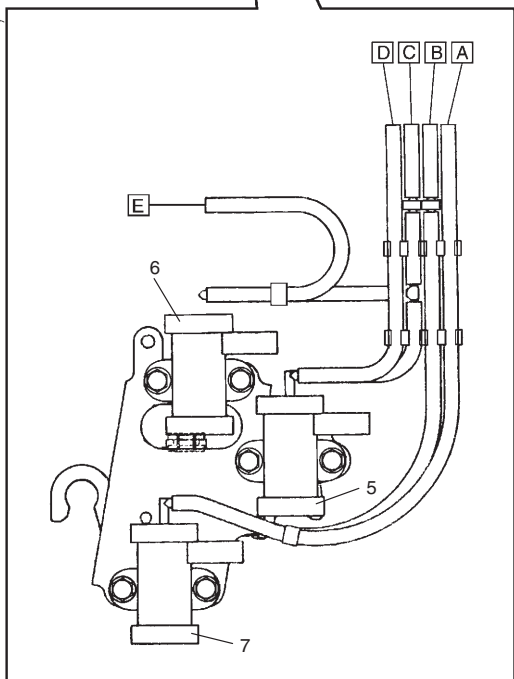
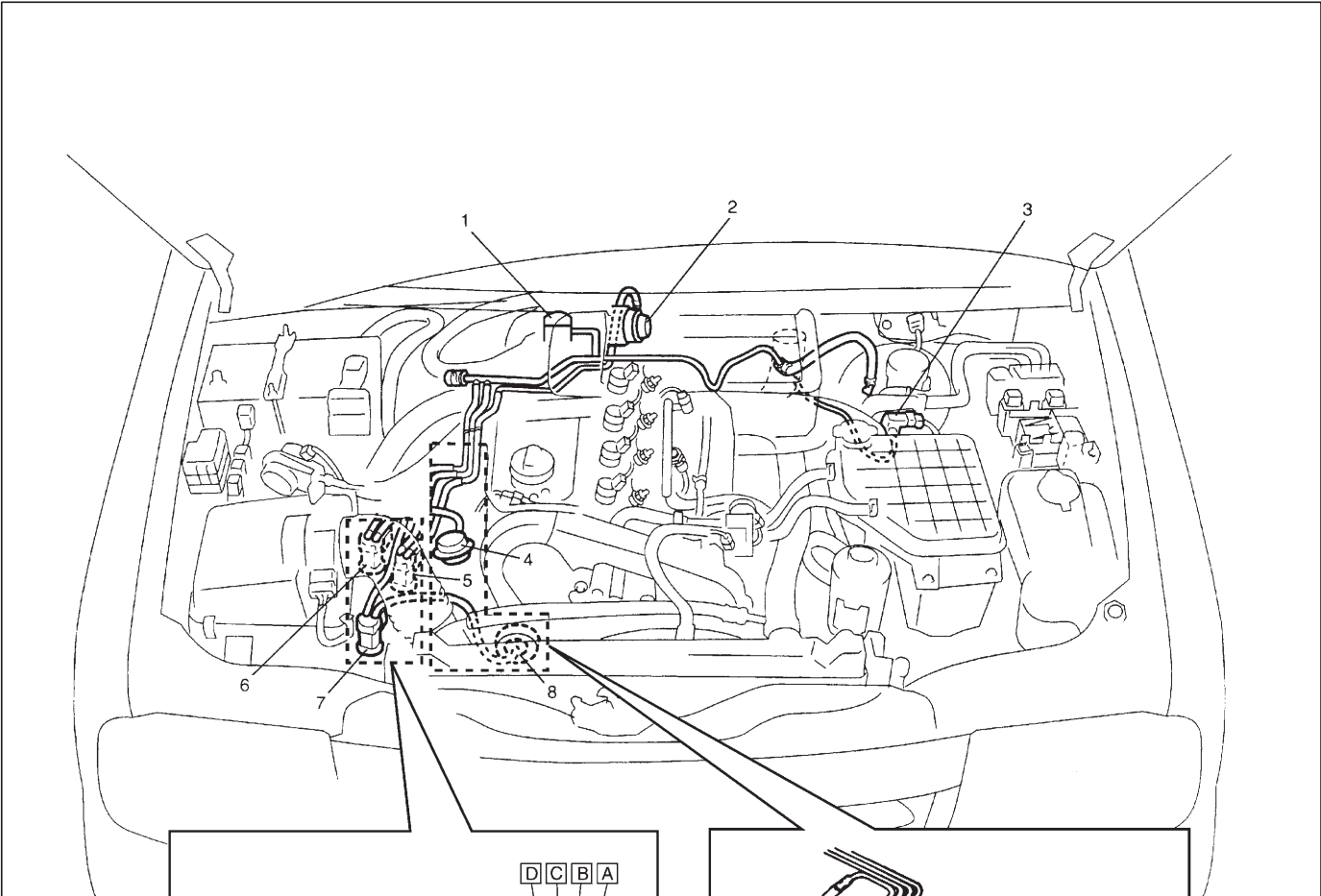

- 1. Vacuum pump
- 2. Throttle valve assembly
- 3. Intake air pressure sensor
- 4. EGR valve
- 5. EGR throttle solenoid valve
- 6. EGR solenoid valve
- 7. Boost (Turbo) pressure regulator solenoid valve
- 8. Waste gate actuator (Turbocharger)

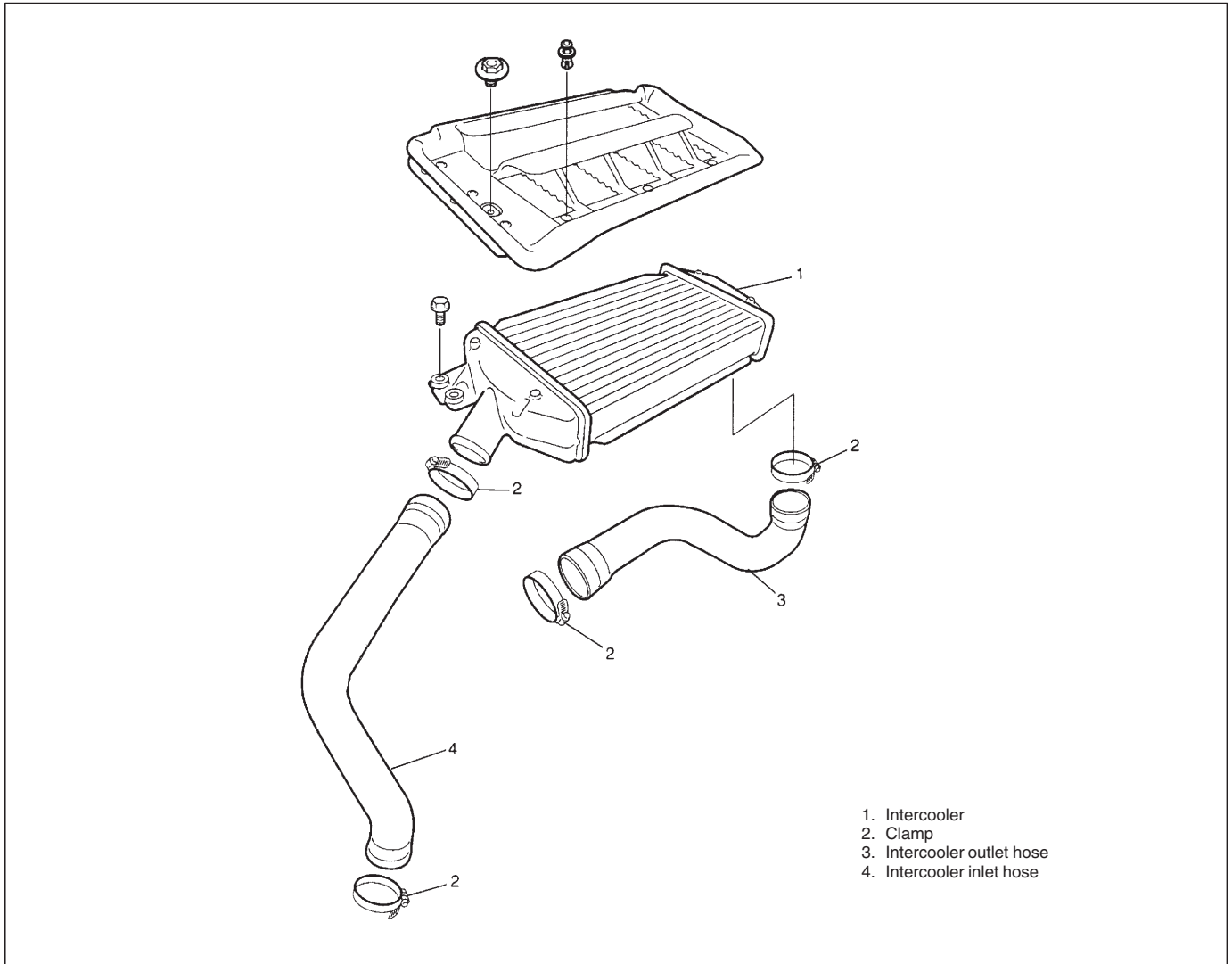
INTERCOOLER**REMOVAL**

- 1) Loosen intercooler hose clamps.
- 2) Remove intercooler.

INSTALLATION

For installation, reverse removal procedure.

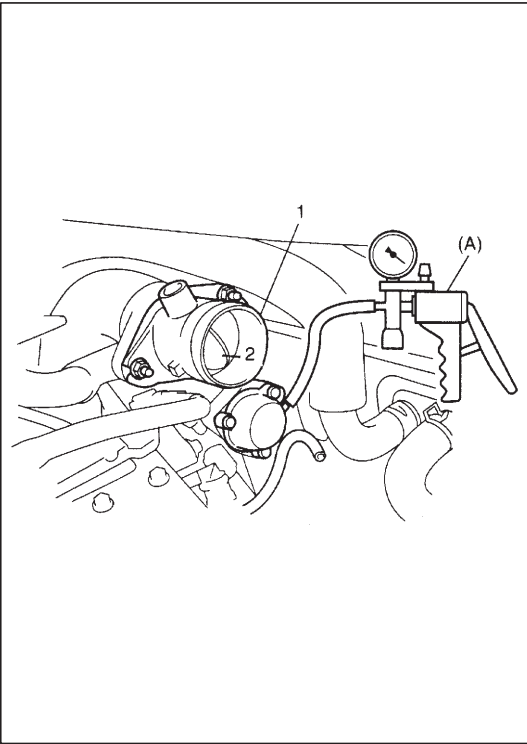

THROTTLE VALVE ASSEMBLY

INSPECTION

- 1) Remove intercooler and intercooler outlet hose.
- 2) Connect a vacuum pump gauge (Special Tool) to throttle valve assembly (1).

Special Tool

(A): 09917-47910

- 3) Gradually increase vacuum and check for throttle valve (2) operation.

If not as specified, replace throttle valve assembly (1).

Valve operation starting vacuum:

0 – About 10.7 kPa (80 mmHg)

Valve operation completion vacuum:

About 50.6 kPa (380 mmHg)

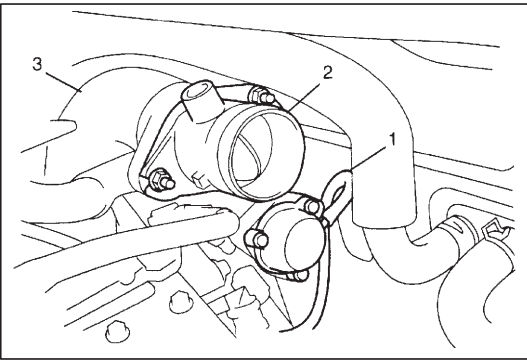

REMOVAL

- 1) Remove intercooler and intercooler outlet hose.
- 2) Disconnect vacuum hose (1) from throttle valve assembly (2).
- 3) Remove throttle valve assembly from elbow air divider (3).

CAUTION:

Don't disassemble throttle valve assembly.

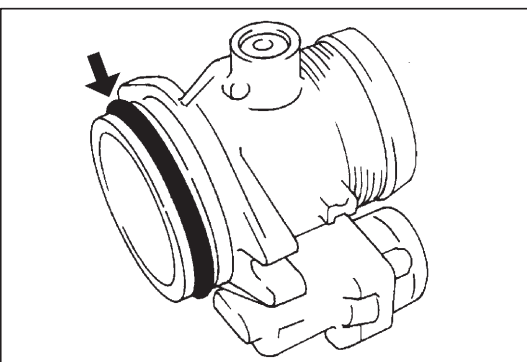

INSTALLATION

Reverse removal procedure for installation noting the following.

- Clean mating surfaces of throttle valve assembly and elbow air divider.
- Check O-ring for damage and replace throttle valve assembly if necessary.

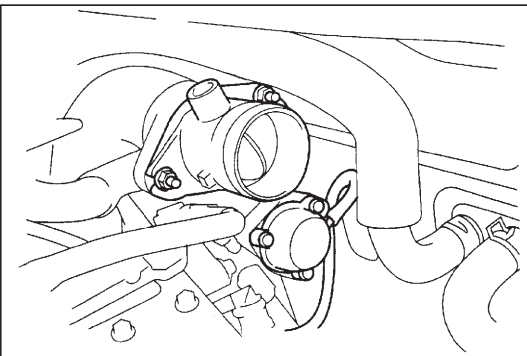

- Connect vacuum hose securely.

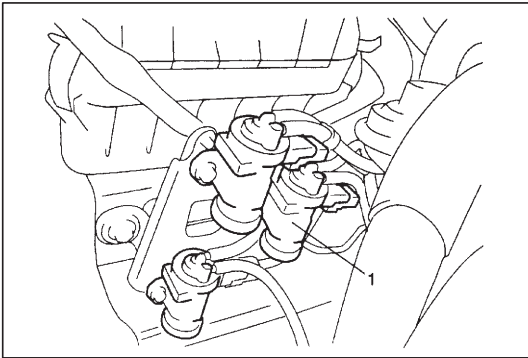

EGR THROTTLE SOLENOID VALVE

REMOVAL

- 1) Disconnect negative cable at battery.
- 2) Remove air cleaner outlet hose.
- 3) Disconnect connector from throttle solenoid valve (1).
- 4) Disconnect vacuum hoses from throttle solenoid valve.
- 5) Remove throttle solenoid valve from bracket.

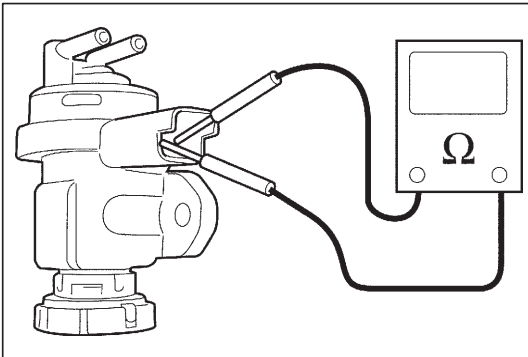

INSPECTION

Measure resistance between each two terminals.

If resistance is out of specification, replace throttle solenoid valve.

Throttle solenoid valve resistance: 15 – 20 Ω

INSTALLATION

For installation, reverse removal procedure.

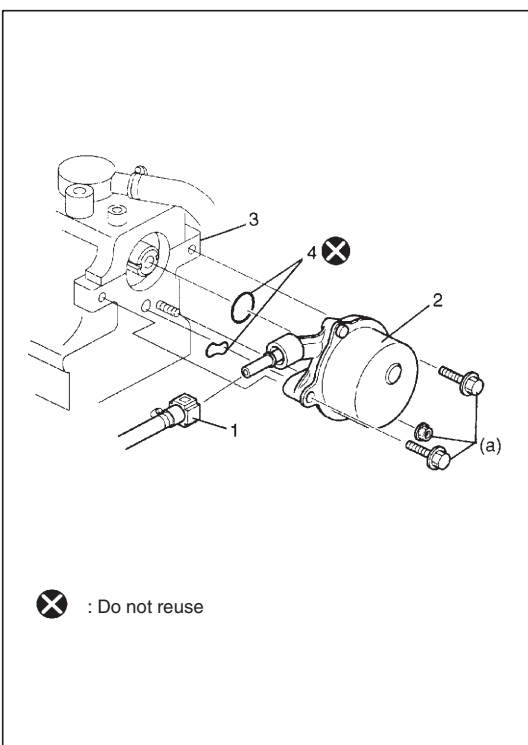

VACUUM PUMP

REMOVAL

- 1) Remove throttle valve assembly referring to “THROTTLE VALVE ASSEMBLY” in this section.
- 2) Remove elbow air divider.
- 3) Disconnect hose (1) from vacuum pump (2).
- 4) Remove vacuum pump from cylinder head (3).

INSTALLATION

For installation, reverse removal procedure noting the following.

- Fit the dogs of vacuum pump coupling into the slot of camshaft.

NOTE:

Use new O-rings (4).

- Install vacuum pump and tighten bolts and nut to specified torque.

Tightening torque

Vacuum pump bolt and nut (a): 20 N·m (2.0 kg·m, 14.5 lb-ft)

TURBOCHARGER

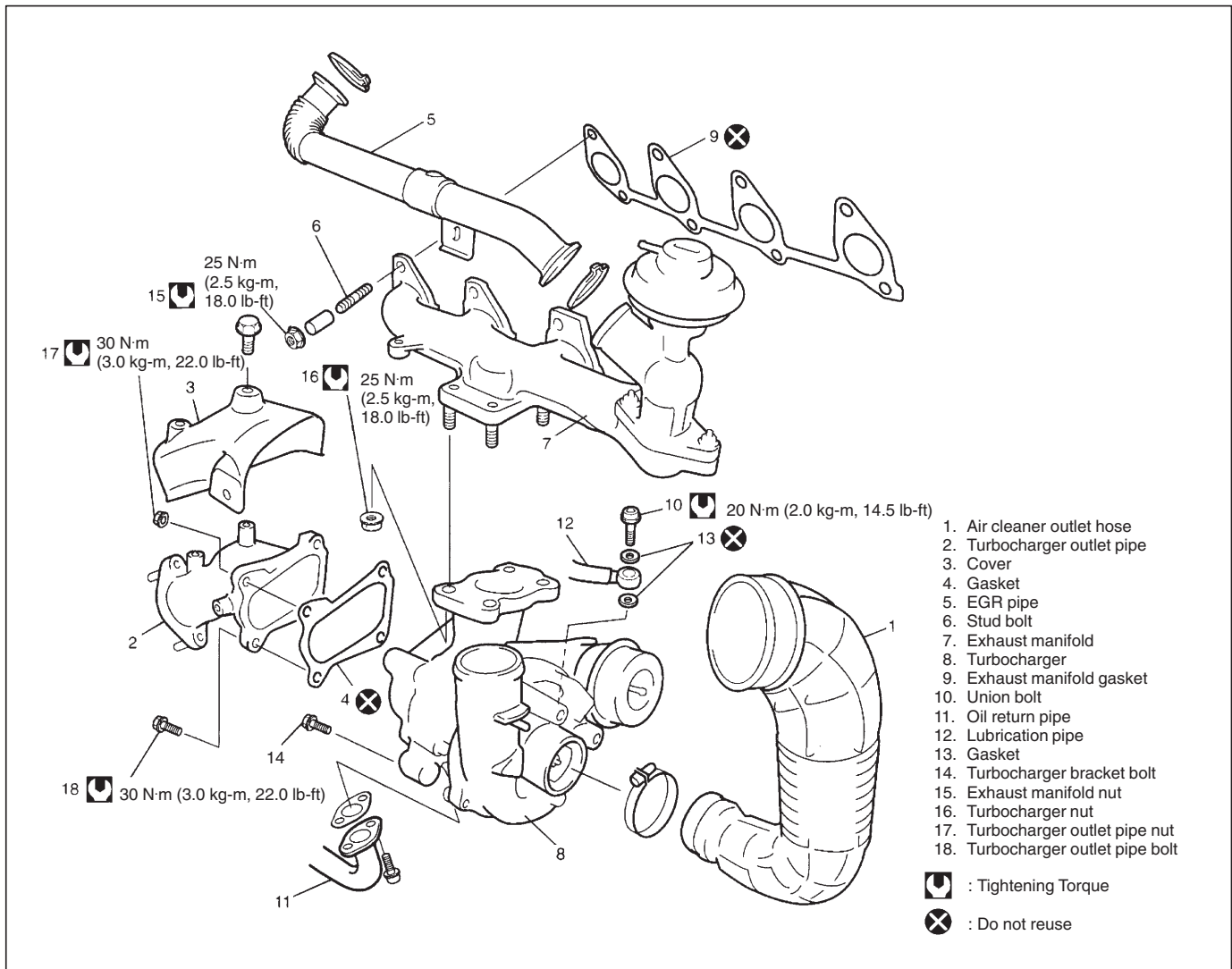

REMOVAL

- 1) Disconnect negative cable at battery.
- 2) Remove intercooler and intercooler inlet hose.
- 3) Remove air cleaner outlet hose and air cleaner case.
- 4) Disconnect vacuum hoses from waste gate actuator and EGR valve.

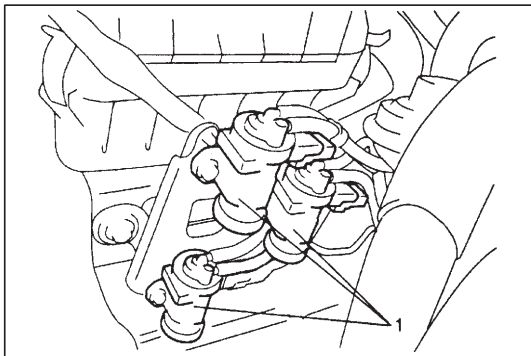

- 5) Detach solenoid valves (1) from its bracket.

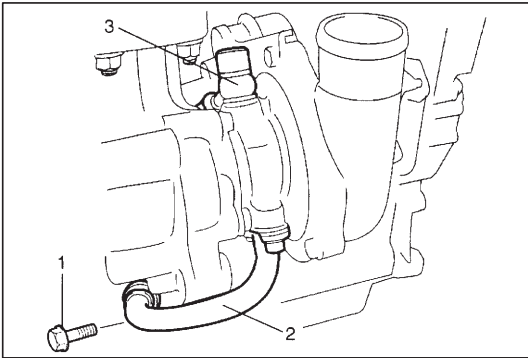

- 6) Remove turbocharger outlet pipe bolts and nuts.
- 7) Remove turbocharger bracket bolt (1).
- 8) Disconnect oil return pipe (2) and lubrication pipe (3) from turbocharger.
- 9) Remove EGR pipe referring to "EGR VALVE" in this section.

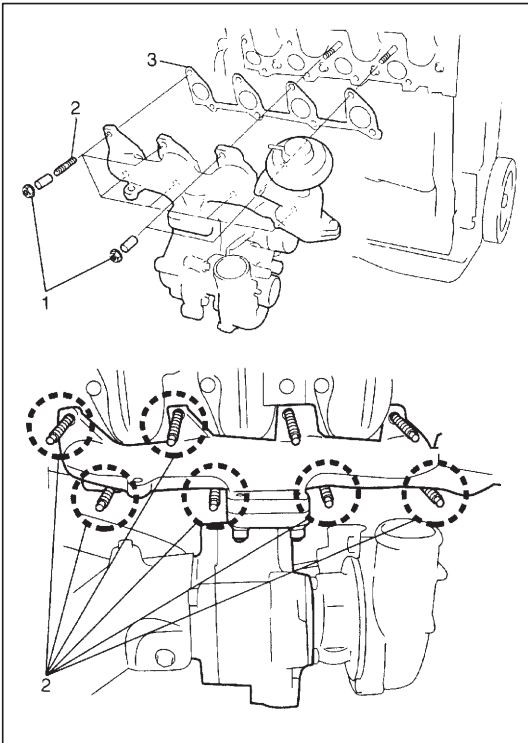

- 10) Remove exhaust manifold nuts (1).
- 11) Remove 6 stud bolts (2) using stud bolt remover.
- 12) Remove turbocharger with exhaust manifold and manifold gasket (3).
- 13) Remove turbocharger from exhaust manifold.

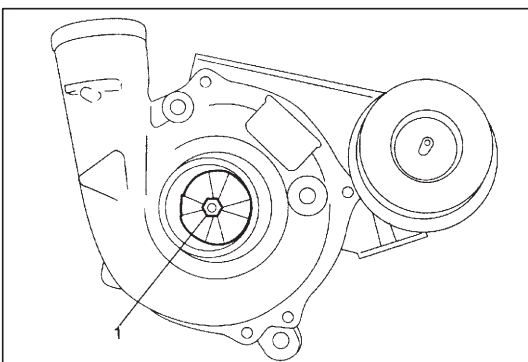

INSPECTION

Rotate turbine shaft (1) by hand and verify that it turns smoothly without any abnormal noise and excessive runout. If not as specified, replace the turbocharger.

INSTALLATION

For installation, reverse removal procedure noting the following.

- Clean mating surfaces of turbocharger, turbocharger outlet pipe, exhaust manifold and cylinder head.
- Use new gaskets.
- Tighten each nuts and bolts to specified torque referring to "TURBOCHARGER" in this section.

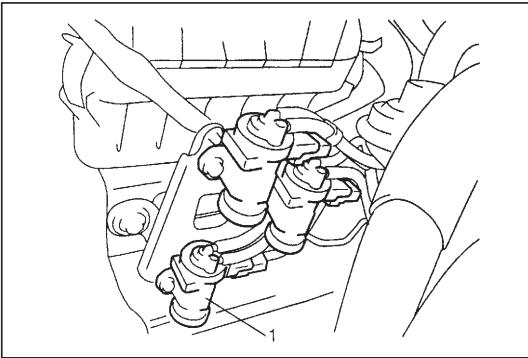

BOOST PRESSURE REGULATOR SOLENOID VALVE REMOVAL

- 1) Disconnect negative cable at battery.
- 2) Remove air cleaner outlet hose.
- 3) Disconnect connector from boost pressure regulator solenoid valve (1).
- 4) Disconnect vacuum hoses from boost pressure regulator solenoid valve.
- 5) Remove boost pressure regulator solenoid valve from bracket.

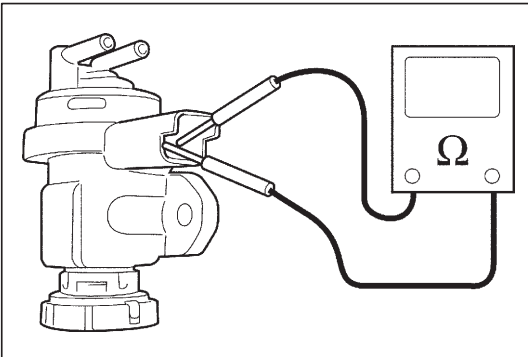

INSPECTION

Measure resistance between each two terminals.

If resistance is out of specification, replace boost pressure regulator solenoid valve.

Boost pressure regulator solenoid valve resistance: 15 – 20 Ω

INSTALLATION

For installation, reverse removal procedure.

GLOW PLUG REMOVAL

CAUTION:

- Do not damage heating section of the glow plug.
- Do not use glow plug that has been dropped from height of over 10 cm (4 in.).
- When removing glow plug, first loosen it by using a tool so that one or more screw threads remain engaged, then loosen and remove by hand.

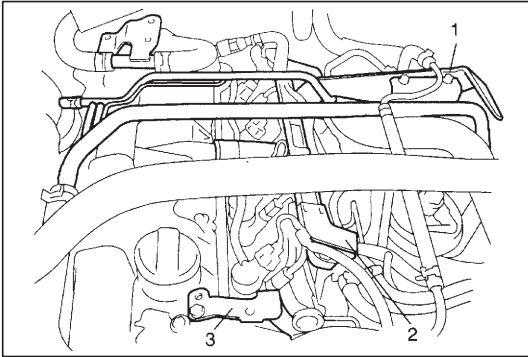

- 1) Disconnect negative cable at battery.
- 2) Remove intercooler and intercooler bracket (1).
- 3) Disconnect each coupler and install wire harness protector (2).
- 4) Remove bracket (3) with fuel heater.

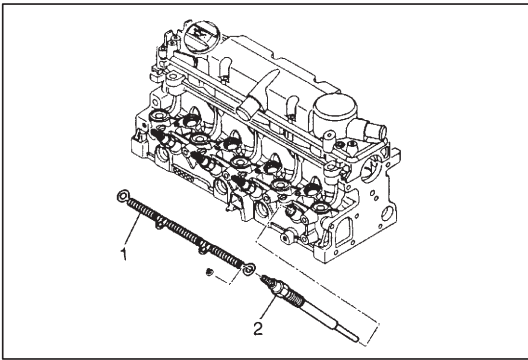

- 5) Disconnect glow plug cable (1) from glow plug (2).
- 6) Remove glow plug from cylinder head.

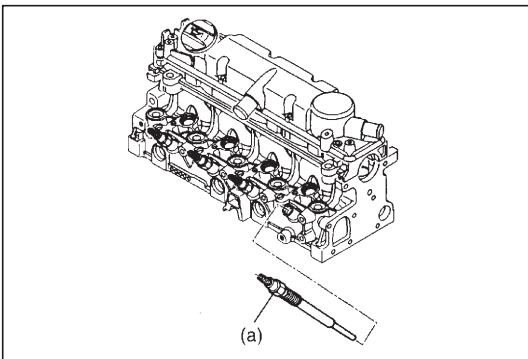

INSTALLATION

For installation, reverse removal procedure noting the following.

- Tighten glow plug to specified torque.

Tightening Torque

Glow plug (a): 10 N·m (1.0 kg-m, 7.5 lb-ft)

FUEL DELIVERY SYSTEM

WARNING

- Fuel vapor is hazardous. It can very easily ignite, causing serious injury and damage. Always keep sparks and flames away from fuel. Fuel line spills and leaks are dangerous. Fuel can ignite and cause serious injuries or death and damage.
- Fuel can also irritate skin and eyes. To prevent this, always complete following "Precautions".

PRECAUTIONS

- When disconnecting a fuel hose or pipe, wrap rag around it to protect against fuel leakage. Plug disconnected hose.
- Before disconnecting a fuel hose or pipe, wait 30 seconds to release pressure in fuel system.
- When disconnecting fuel line from injection pump, injector, delivery pipe and/or fuel filter, install new plug or new cap including in fuel system plug set (special tool) to fittings immediately in order to prevent its internal part from dust.

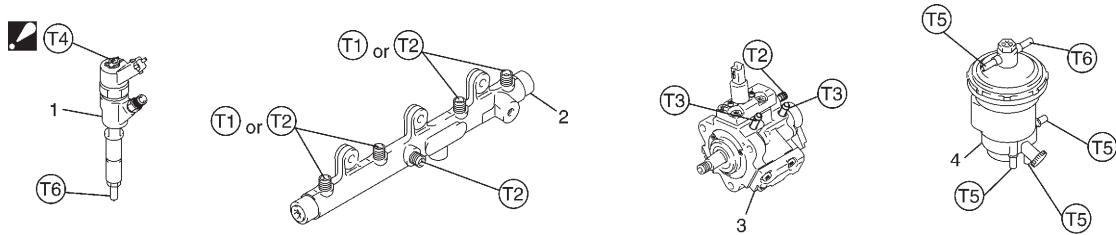

⊗ (A):

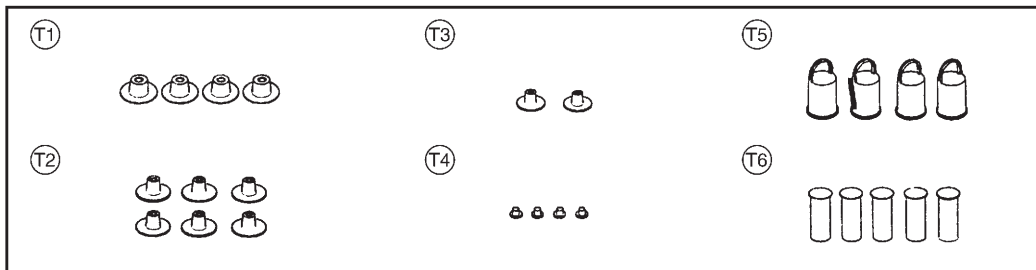

▣ : Fix special tool with injector hose clip.

⊗ : Do not reuse

1. Injector
2. Delivery pipe
3. Injection pipe
4. Fuel filter

Special Tool

(A): 09916-50010

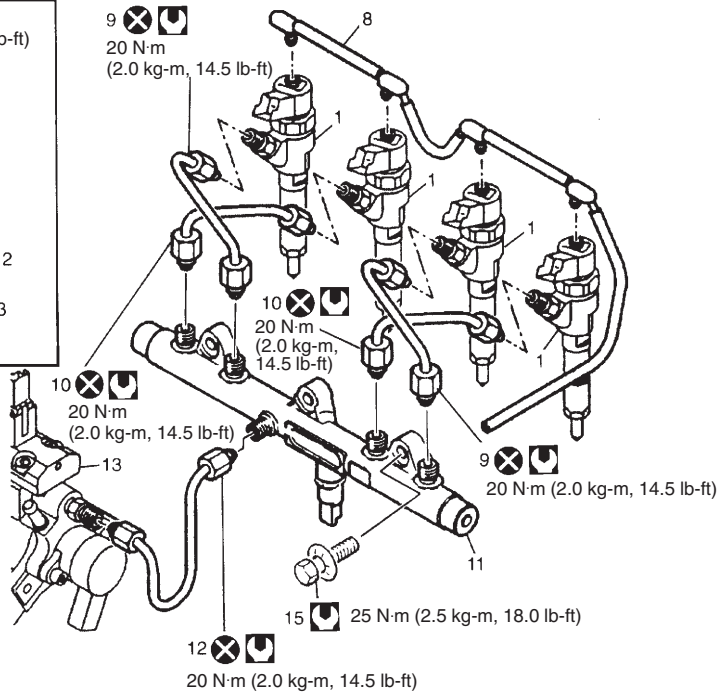
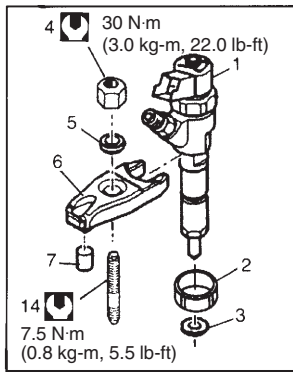
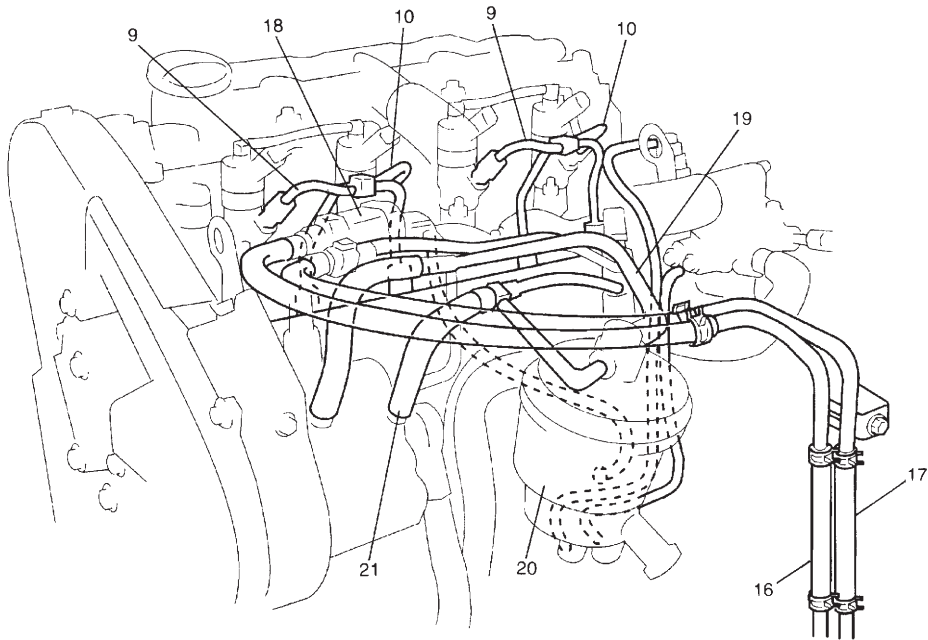

1. Fuel injector
2. Sealing ring
3. Copper seal
4. Nut
5. Washer
6. Injector clamp
7. Thrust button
8. Return hose
9. High pressure pipe (for No.2 & No.4)
10. High pressure pipe (for No.1 & No.3)
11. Common rail (High pressure fuel injection rail)
12. High pressure supply pipe
13. Injection pump
14. Stud bolt
15. Bolt
16. Fuel feed hose
17. Fuel return hose
18. Fuel heater
19. Inlet fuel hose
20. Fuel filter assembly
21. Return fuel hose

: Tightening Torque
 : Do not reuse

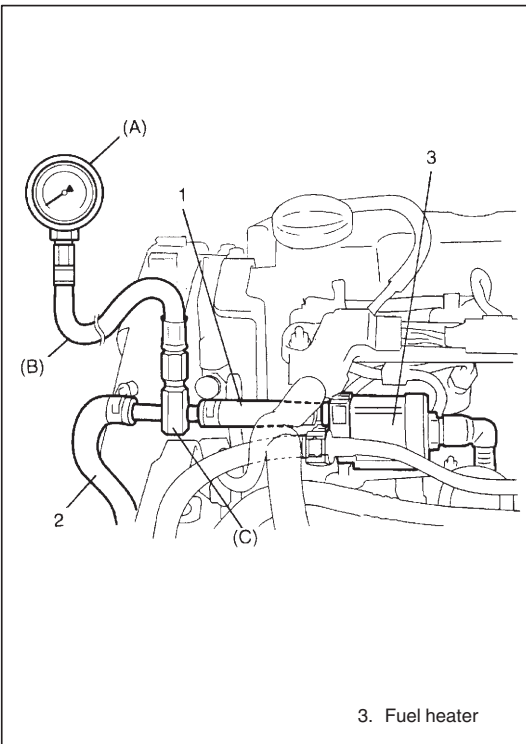

LOW PRESSURE FUEL SUPPLY SYSTEM INSPECTION

- 1) Disconnect fuel feed hose (1) from fuel feed pipe.

CAUTION:

A small amount of fuel may be released when fuel feed hose is removed. Place container under the fuel feed hose or fuel feed pipe with a shop cloth so that released fuel is caught in container or absorbed in cloth. Place that cloth in an approved container.

- 2) Connect special tools and hose (2) between fuel feed hose and fuel feed pipe as shown in figure, and clamp hose securely to ensure no leaks occur during checking.

Special Tool

(A): 09912-58441

(B): 09912-58431

(C): 09912-58490

- 3) Check that battery voltage is above 11 V.
- 4) Turn ignition switch ON to operate fuel pump and after 5 seconds turn it OFF. Repeat this 6 times and then check fuel pressure.
- 5) Start engine.
- 6) Measure fuel pressure at idling.
If measure pressure doesn't satisfy specification, refer to "Diagnostic Flow Table B-2" in Section 6 and check each possibly defective part. Replace if found defective.
- 7) After checking fuel pressure, remove special tools and hose from fuel feed pipe.
- 8) Connect fuel feed hose and clamp it securely.
- 9) With engine "OFF" and ignition switch "ON", check for fuel leaks.

CONDITION	FUEL PRESSURE
With fuel pump operating and engine stopped (Within about 5 seconds after ignition switch ON)	about 220 kPa 2.2 kg/cm ² 31.3 psi
At specified idle speed	about 280 kPa 2.8 kg/cm ² 39.8 psi
With fuel pump stopped	0 kPa 0 kg/cm ² 0 psi

FUEL PUMP

ON-VEHICLE INSPECTION

- 1) Check that fuel pump operating sound is heard from fuel pump for 5 seconds and then stop when turning on ignition switch.
If above check result is not satisfactory, advance to “Diagnostic Flow Table B-1” in Section 6.

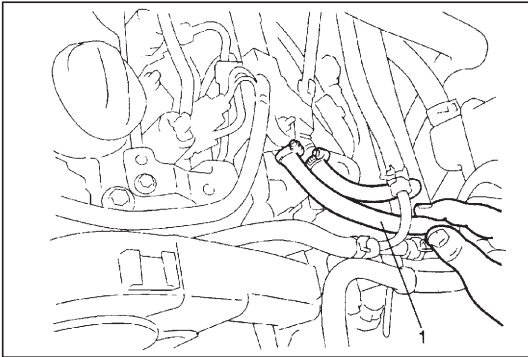

- 2) Check that fuel pressure is felt at fuel feed hose (1) for about 5 seconds after ignition switch ON.
If fuel pressure is not felt, advance to “Diagnostic Flow Table B-3” in following section.
 - For vehicle equipped with single-connector ECM : Section 6
 - For vehicle equipped with triple-connector ECM : Section 6-1

REMOVAL/INSPECTION/INSTALLATION

Refer to “FUEL PUMP” in Section 6C.

FUEL HEATER

Refer to “FUEL HEATER” in Section 6C.

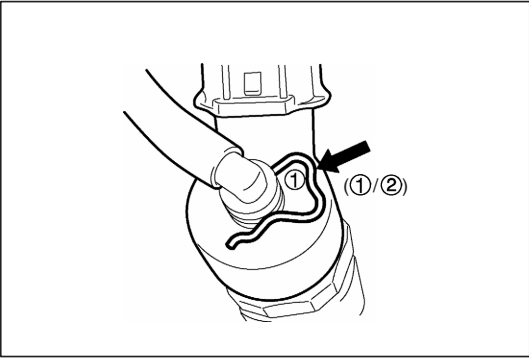

FUEL INJECTOR

NOTE:

There are two types of the fuel injector depending on the engine. When the fuel injector(s), one, two, three or all, is replaced, identify the fuel injector type by the identification mark "1" or "2" as shown in figure.

And then, replace the injector(s) with the same type of fuel injector as the original installed.

Never mix the types per engine or replace to the other type fuel injector from the original type fuel injector.

Otherwise engine noise and vibration are increases.

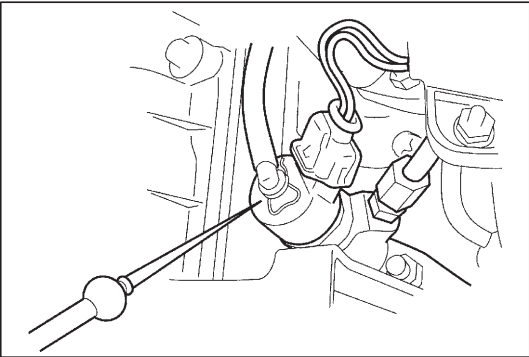

ON-VEHICLE INSPECTION

- 1) Using sound scope or such, check operating sound of injector when engine is running or cranking.

Cycle of operating sound should vary according to engine speed.

If no sound or an unusual sound is heard, check injector circuit (wire or coupler) or injector.

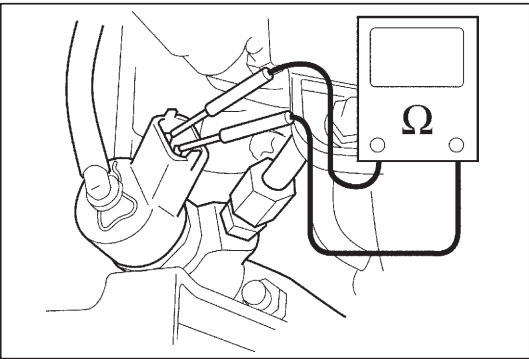

- 2) Disconnect coupler from injector, connect ohmmeter between terminals of injector and check resistance. If resistance is out of specification, replace.

Resistance of injector: 0.56 Ω (MAX.) (at 20°C, 68 °F)

- 3) Connect coupler to injector securely.

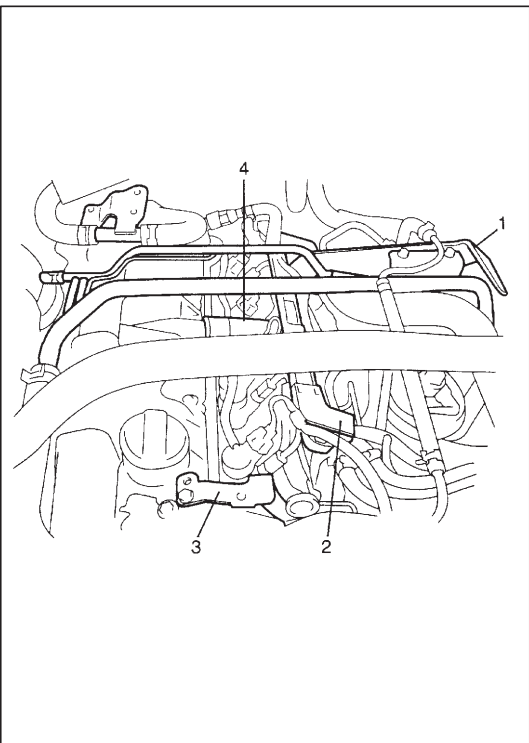

REMOVAL

- 1) Disconnect negative cable at battery.
- 2) Remove intercooler referring to "INTERCOOLER" in this section.
- 3) Remove intercooler bracket (1) and bracket (3) with fuel heater.
- 4) Disconnect fuel temperature sensor connector, injector connectors, CMP sensor connector and high pressure fuel pump solenoid valve connector. Then detach wire harness protector (2) and PCV hose (4).

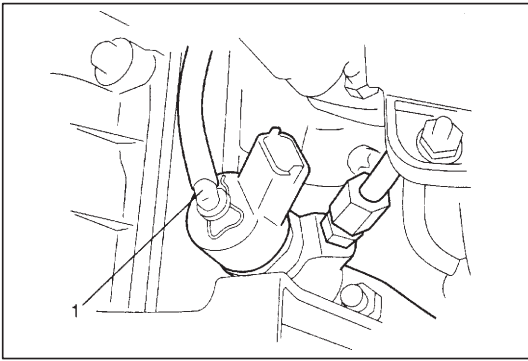

5) Disconnect return hose (1) from injector.

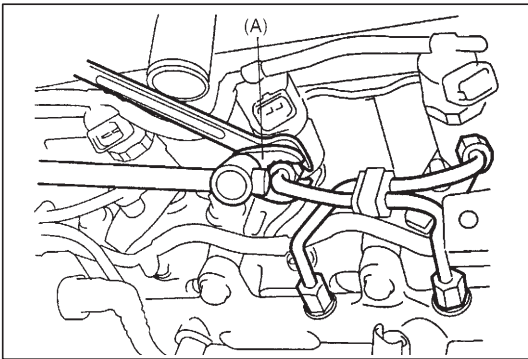

6) Remove high pressure pipe.
When loosening union nut of high pressure pipe, hold union nut of injector with wrench as shown.

Special Tool

(A): 09950-76510/OUT0000148

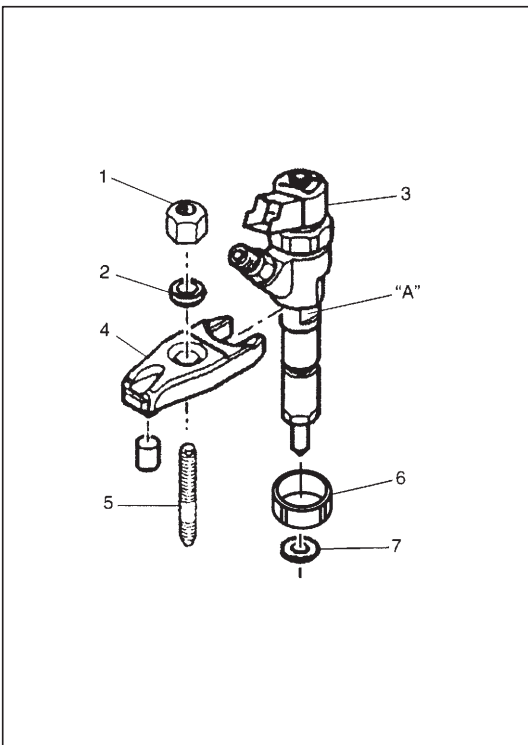

7) Remove nut (1) and washer (2), then remove injector (3) with its clamp (4).

NOTE:

If the injector cannot be removed, remove the stud bolt (5) by using stud bolt remover then, using an opened spanner, turn the injector at "A".

8) Remove sealing ring (6) and copper seal (7).

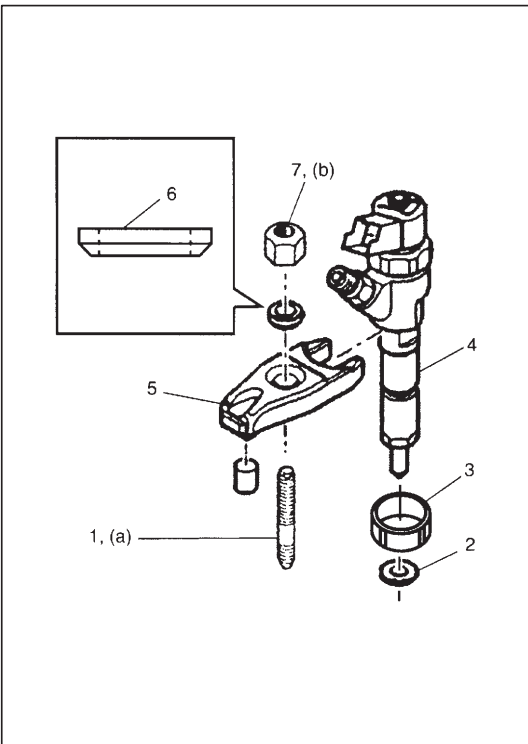

INSTALLATION

- 1) Install stud bolt (1) to cylinder head, if removed.

Tightening Torque

Fuel injector stud bolt (a): 7.5 N·m (0.8 kg-m, 5.5 lb-ft)

- 2) Install new copper seal (2) and new sealing ring (3).
- 3) Install injector (4) with its clamp (5) to cylinder head.
- 4) Install washer (6) in proper direction as shown in figure and then tighten nut (7) to specified torque.

Tightening Torque

Fuel injector nut (b): 30 N·m (3.0 kg-m, 22.0 lb-ft)

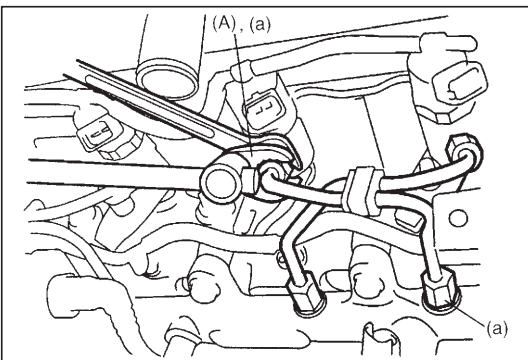

- 5) Install new high pressure pipe.
When tightening union nuts of high pressure pipe, hold union nut of injector with wrench as shown.

Special Tool

(A): 09950-76510/OUT0000148

Tightening Torque

**High pressure pipe union nut (a):
20 N·m (2.0 kg-m, 14.5 lb-ft)**

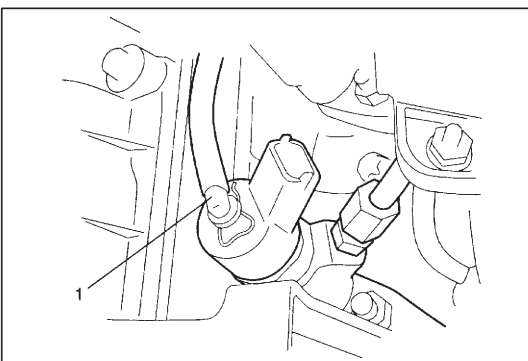

- 6) Connect return hose (1) to injector.
- 7) Connect coupler to injector.

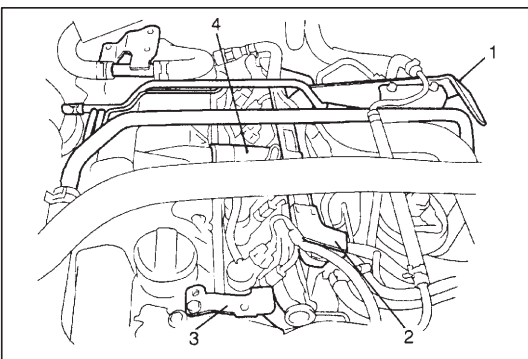

- 8) Install PCV hose (4) and wire harness protector (2), then connect each connector securely.
- 9) Install intercooler bracket (1) and bracket (3) with fuel heater.

- 10) Install intercooler referring to "INTERCOOLER" in this section.
- 11) Connect negative cable at battery.
- 12) Check that fuel is not leaking by performing the procedure below.
 - (1) Start engine and warm up to normal operating temperature.
 - (2) Check fuel leakage after turning off ignition switch.
 - (3) Again, start engine and accelerate the vehicle up to 3500 rpm with L range (AT) or 1st gear (MT). Then stop vehicle.
 - (4) Check fuel leakage after turning off ignition switch.

COMMON RAIL (HIGH PRESSURE FUEL INJECTION RAIL)

REMOVAL

- 1) Disconnect negative cable at battery.
- 2) Remove intercooler referring to "INTERCOOLER" in this section.
- 3) Remove fuel temperature sensor referring to "FUEL TEMPERATURE SENSOR" in this section.
- 4) Remove bracket (1) with fuel heater (2) and detach PCV hose (3).

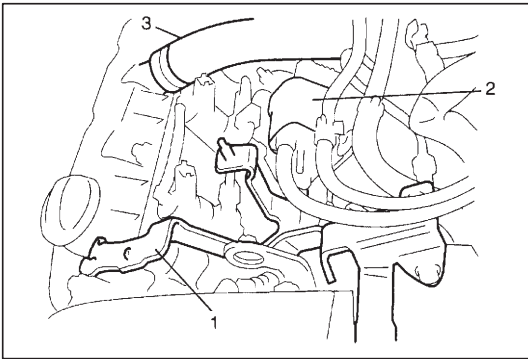

- 5) Remove high pressure pipes from injectors and common rail. When loosening union nut of high pressure pipe, hold union nut of injector with wrench as shown in figure.

Special Tool

(A): 09950-76510/OUT0000148

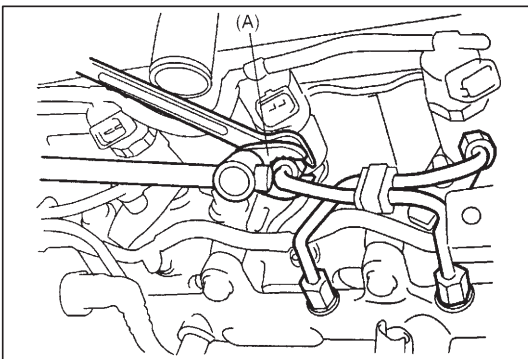

- 6) Remove high pressure supply pipe from injection pump and common rail. When loosening union nut of high pressure supply pipe, hold union nut of injection pump with wrench as shown in figure.

Special Tool

(A): 09950-76510/OUT0000148

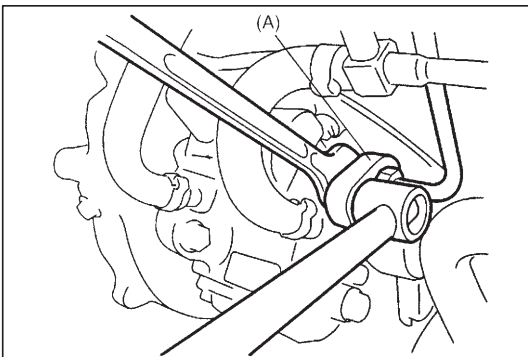

- 7) Disconnect connector from fuel pressure sensor.

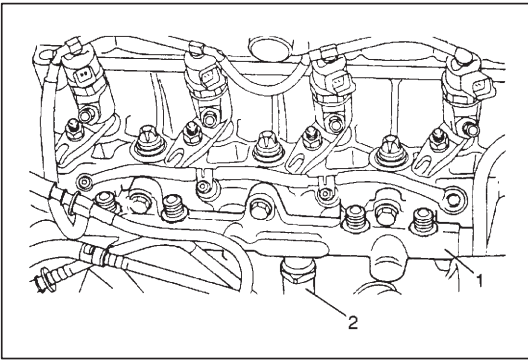

- 8) Remove common rail (1).
- 9) Remove fuel pressure sensor (2) from common rail.

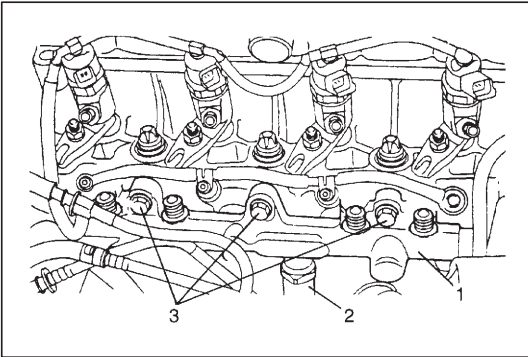

INSTALLATION

- 1) Install fuel pressure sensor (2) to common rail (1).
Tighten fuel pressure sensor to specified torque referring to "FUEL PRESSURE SENSOR" in this section.
- 2) Install common rail (1) and tighten bolts (3) temporarily by hand.
- 3) Connect connector to fuel pressure sensor.

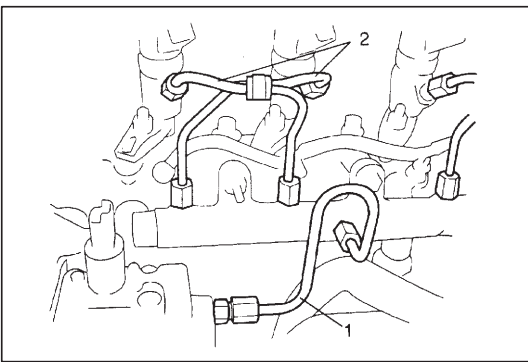

- 4) Install high pressure supply pipe (1) and high pressure pipes (2), tighten each union nuts temporarily by hand.

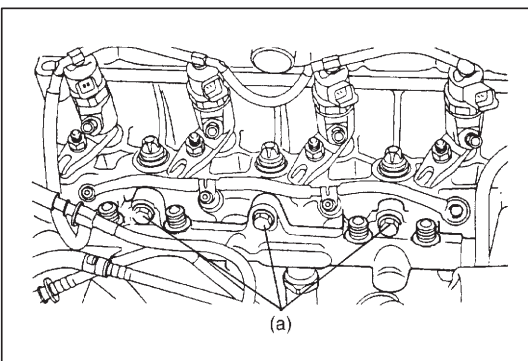

- 5) Tighten common rail bolts to specified torque.

Tightening Torque

Common rail bolt (a): 25 N·m (2.5 kg·m, 18.0 lb·ft)

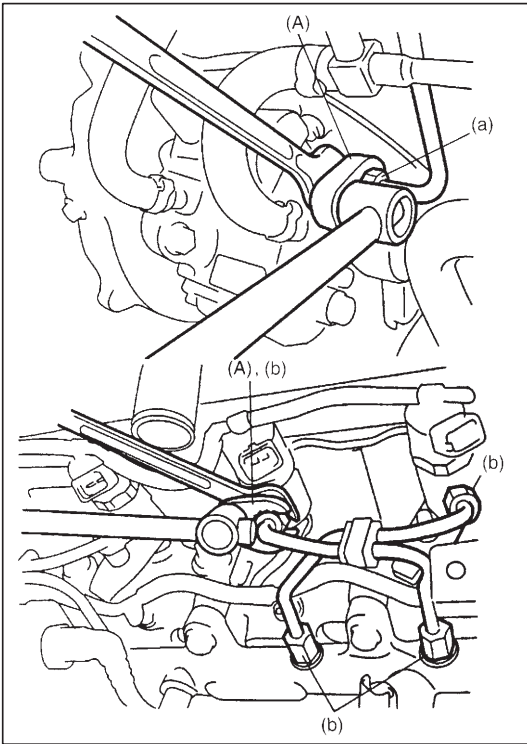

- 6) Tighten union nuts of high pressure supply pipe and high pressure pipes to specified torque.
When tightening each union nut, hold union nuts of injector and injection pump with wrench as shown.

Special Tool

(A): 09950-76510/OUT0000148

Tightening Torque

High pressure supply pipe union nut

(a): 20 N·m (2.0 kg-m, 14.5 lb-ft)

High pressure pipe union nut

(b): 20 N·m (2.0 kg-m, 14.5 lb-ft)

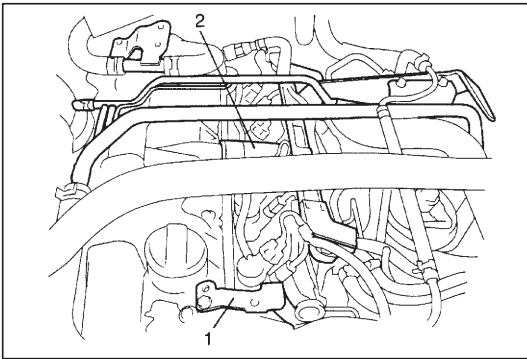

- 7) Install PCV hose (2) and bracket (1).
8) Install fuel temperature sensor referring to "FUEL TEMPERATURE SENSOR" in this section.
9) Install intercooler referring to "INTERCOOLER" in this section.
10) Connect negative cable at battery.
11) Check fuel leakage by performing step 12) described in "FUEL INJECTOR INSTALLATION" in this section.

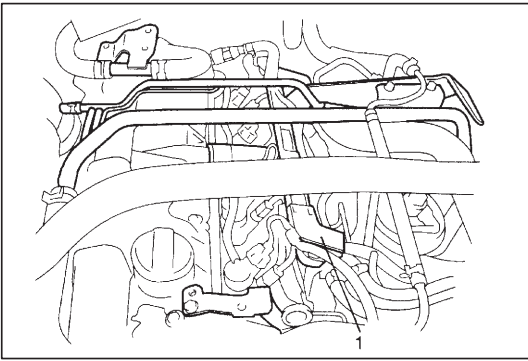

INJECTION PUMP

REMOVAL

- 1) Disconnect negative cable at battery.
- 2) Disconnect each connector and detach wire harness protector (1).
- 3) Remove timing belt referring to "TIMING BELT AND BELT TENSIONER" in Section 6A3.

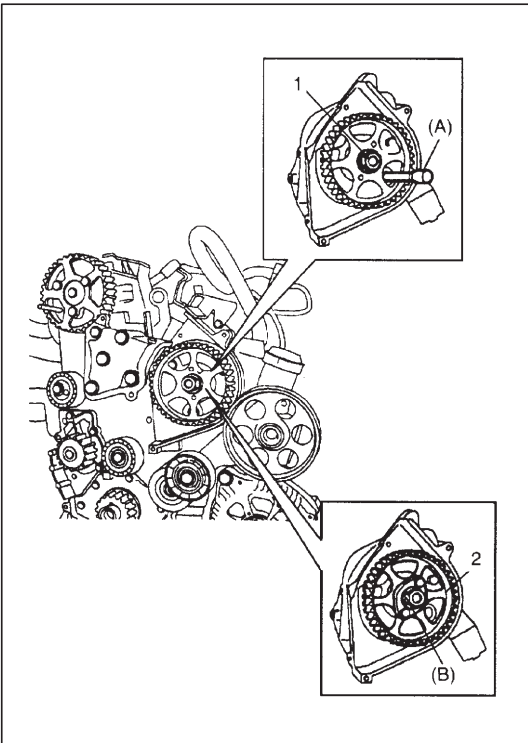

- 4) Loosen injection pump pulley nut (1) with pulley locked by using special tool.

Special Tool

(A): 09919-56570/OUT0000157

- 5) Remove injection pump pulley (2) by using special tool.

Special Tool

(B): 09919-56580/OUT0000158

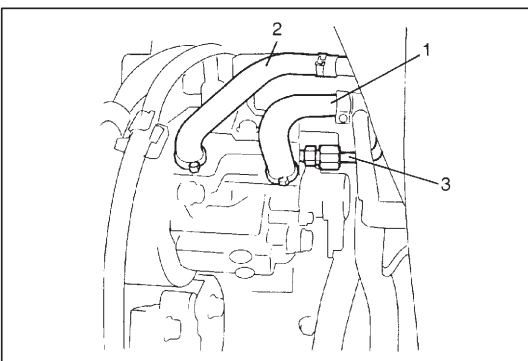

- 6) Disconnect inlet fuel hose (2) and return fuel hose (1) from injection pump.
- 7) Remove high pressure supply pipe (3) from injection pump.

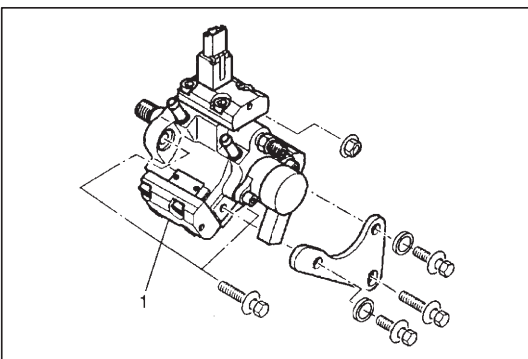

- 8) Remove injection pump (1).

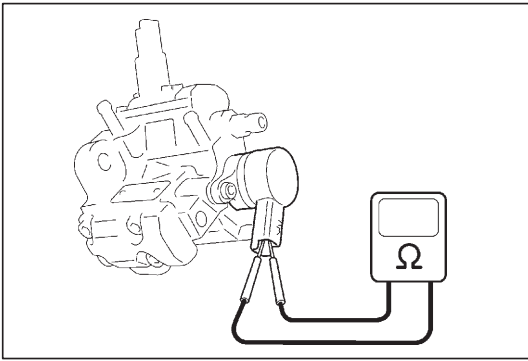

INSPECTION

Fuel Pressure Regulator

Check resistance between terminals of fuel pressure regulator. If found faulty, replace injection pump.

Resistance of fuel pressure regulator: 2 – 3 Ω

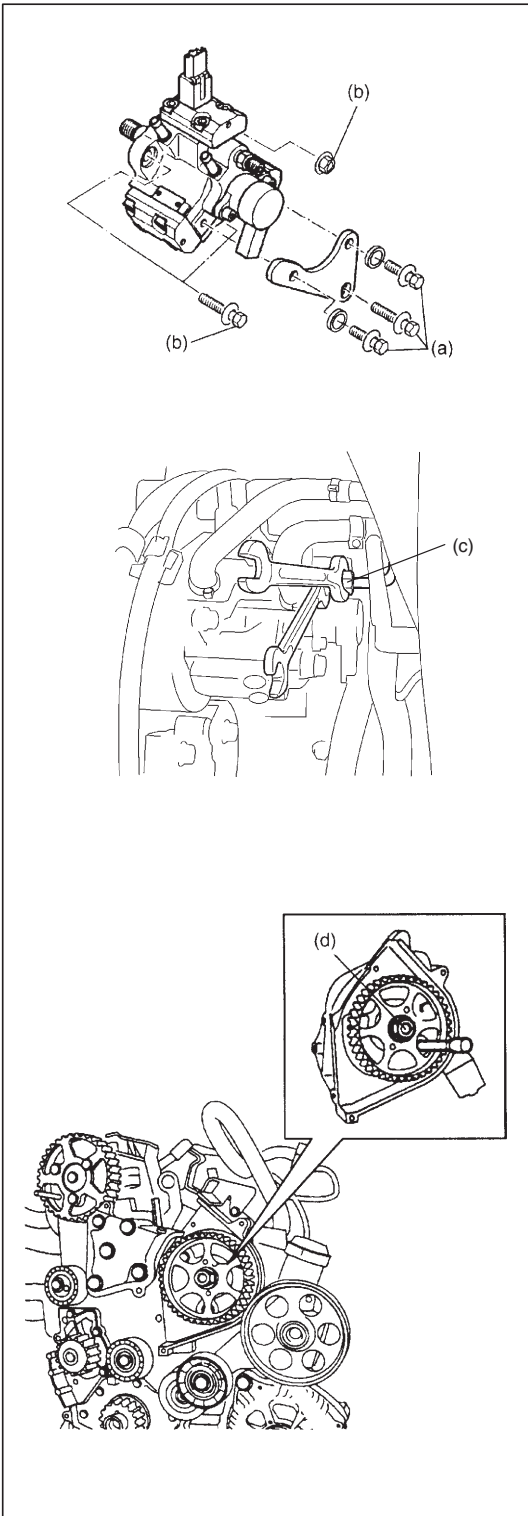

INSTALLATION

For installation reverse removal procedure noting the following.

- When tightening union nut of high pressure supply pipe, hold union nut of injection pump with wrench.

Special Tool

(A): 09950-76510/OUT0000148

- Tighten each bolt and nut to specified torque.

Tightening Torque

Injection pump bracket bolt

(a): 20 N·m (2.0 kg-m, 14.5 lb-ft)

Injection pump nut and bolt

(b): 22.5 N·m (2.3 kg-m, 16.5 lb-ft)

High pressure supply pipe union nut

(c): 20 N·m (2.0 kg-m, 14.5 lb-ft)

Injection pump pulley nut

(d): 50 N·m (5.0 kg-m, 36.5 lb-ft)

- Install timing belt referring to “TIMING BELT AND BELT TENSIONER” in Section 6A3.
- Check fuel leakage by performing step 12) described in “FUEL INJECTION INSTALLATION” in this section.

ELECTRONIC CONTROL SYSTEM ENGINE CONTROL MODULE (ECM)

CAUTION:

As ECM consists of precision parts, be careful not to expose it to excessive shock.

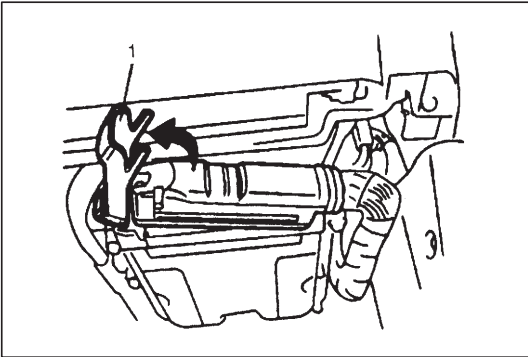

For Vehicle Equipped with Single-Connector ECM

REMOVAL

- 1) Disconnect negative cable at battery.
- 2) Disable air bag system (if equipped) referring to “Disabling the Air Bag System” in Air Bag System section.
- 3) Remove ECM cover clips and then remove ECM cover from bracket by pulling off the cover to the seat side.
- 4) Disconnect ECM connector from ECM by pulling off lock (1).
- 5) Remove ECM (1) from bracket.

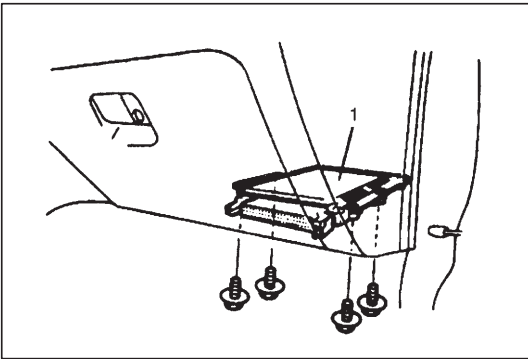

INSTALLATION

- 1) Connect connectors to ECM securely.
- 2) Install ECM to bracket.
- 3) Install ECM cover to ECM bracket.
- 4) Enable air bag system (if equipped) referring to “Enabling Air Bag System” in Air Bag System section.
- 5) Connect negative cable to battery.

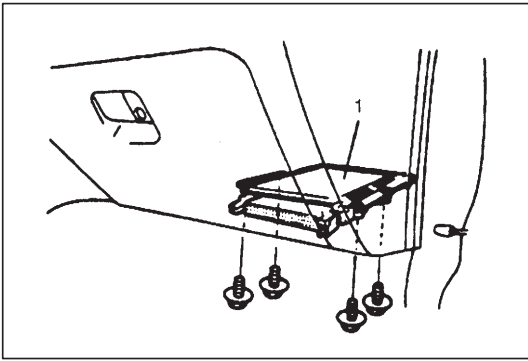

For Vehicle Equipped with Triple-Connector ECM

REMOVAL

- 1) Disconnect negative cable at battery.
- 2) Disable air bag system (if equipped) referring to “Disabling the Air Bag System” in Air Bag System section.
- 3) Remove ECM cover clips and then remove ECM cover from bracket by pulling off the cover to the seat side.
- 4) Remove ECM (1) from bracket.

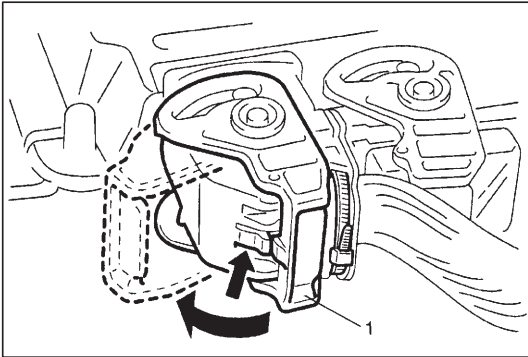

- 5) Disconnect ECM connector from ECM by pulling off lock (1).

INSTALLATION

- 1) Connect connectors to ECM securely.
- 2) Install ECM to bracket.
- 3) Install ECM cover to ECM bracket.
- 4) Enable air bag system (if equipped) referring to “Enabling Air Bag System” in Air Bag System section.
- 5) Connect negative cable to battery.

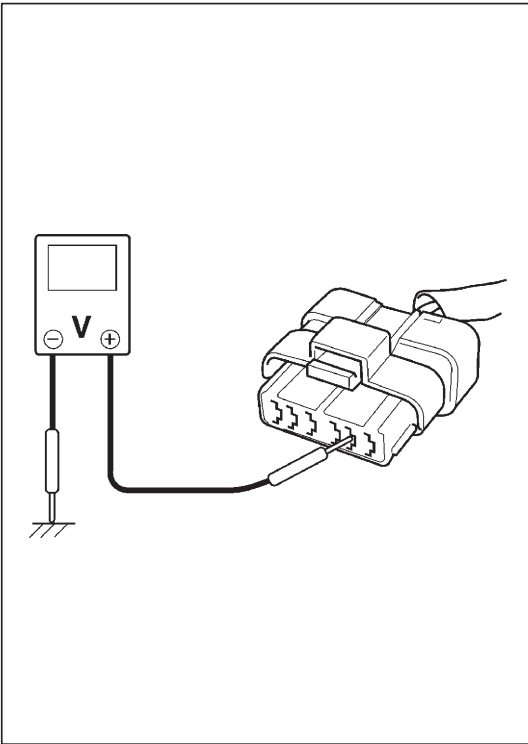

MASS AIR FLOW SENSOR (MAF SENSOR)

INSPECTION

NOTE:

Use voltmeter with high-impedance (10 k Ω /V minimum) or digital type voltmeter.

- 1) Connect voltmeter to "BLK/WHT" wire terminal of MAF sensor coupler disconnected and ground.
- 2) Turn ignition switch ON and check that voltage is battery voltage.
If not, check if wire harness is open or connection is poor.

- 3) Connect MAF sensor coupler to MAF sensor.
- 4) Check voltage at MAF sensor output terminal "C51-13" or "E228-29" referring to "VOLTAGE CHECK" in following section.
 - For vehicle equipped with single-connector ECM : Section 6
 - For vehicle equipped with triple-connector ECM : Section 6-1

Voltage: About 0.6 V

- 5) Start engine and check that voltage is lower than 5 V and it rises as engine speed increases.
(Reference data: about 2.6 V at specified idle speed)
If check result is not as specified above, cause may lie in wire harness, coupler connection, MAF sensor or ECM.

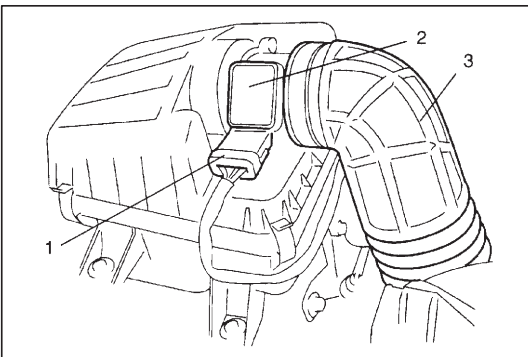

REMOVAL

- 1) Disconnect negative cable at battery and coupler (1) from MAF sensor (2).
- 2) Remove air cleaner outlet hose (3) from turbocharger and MAF sensor.

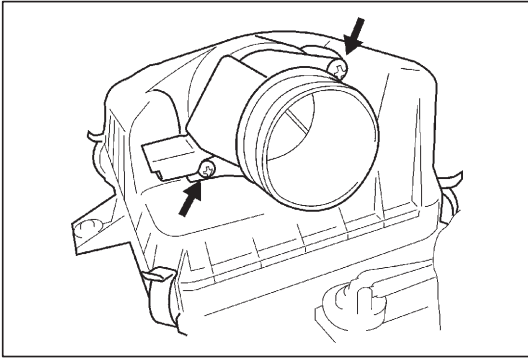

- 3) Remove MAF sensor from air cleaner case.

NOTE:

Don't disassemble MAF sensor.

CAUTION:

- Do not expose MAF sensor to any shock.
- Do not blow compressed air by using air gun or the like.
- Do not put finger or any other object into MAF sensor. Malfunction may occur.

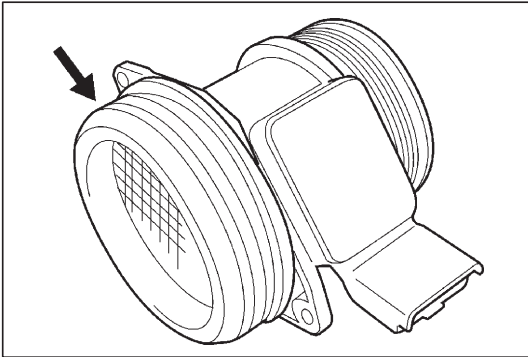
**INSTALLATION**

- 1) Check MAF sensor seal for deterioration and damage.
- 2) Install MAF sensor to air cleaner case.
- 3) Install air cleaner outlet hose.
- 4) Connect MAF sensor coupler securely.
- 5) Connect battery negative cable to battery.

THROTTLE POSITION SENSOR (TP SENSOR) (ACCELERATOR STROKE SENSOR)

INSPECTION

Refer to "DTCs P0121, P0221 and P0604" in following section.

- For vehicle equipped with single-connector ECM : Section 6
- For vehicle equipped with triple-connector ECM : Section 6-1

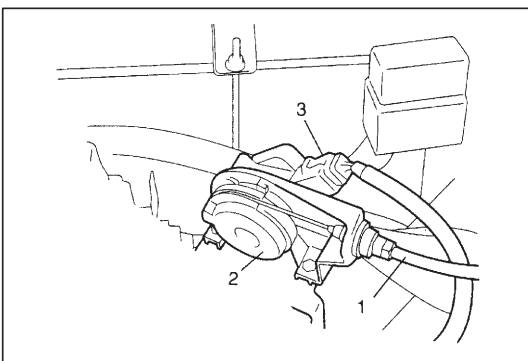
**REMOVAL**

- 1) Disconnect negative cable at battery.
- 2) Disconnect accelerator cable (1) from TP sensor (2).
- 3) Disconnect coupler (3) from TP sensor.
- 4) Remove TP sensor with its bracket (4).

INSTALLATION

For installation, reverse removal procedure noting the following.

- Adjust accelerator cable play to specification referring to "ACCELERATOR CABLE ADJUSTMENT" in this section.

FUEL TEMPERATURE SENSOR ASSEMBLY

REMOVAL

- 1) Disconnect negative cable at battery.
- 2) Remove intercooler referring to "INTERCOOLER" in this section.
- 3) Remove intercooler bracket (1).
- 4) Disconnect fuel temperature sensor connector, injector connector, CMP sensor connector and injection pump solenoid valve connector. Then detach wire harness protector (2).

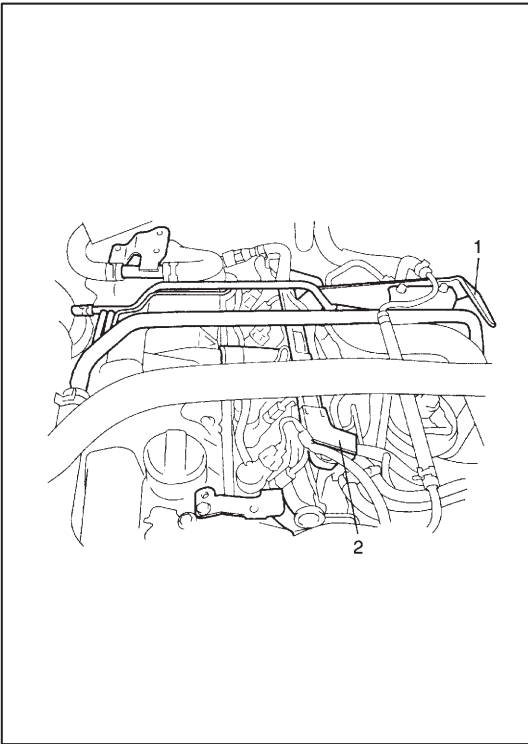

- 5) Disconnect fuel temperature sensor assembly (1) from fuel filter (2), injection pump and fuel return hose (3).

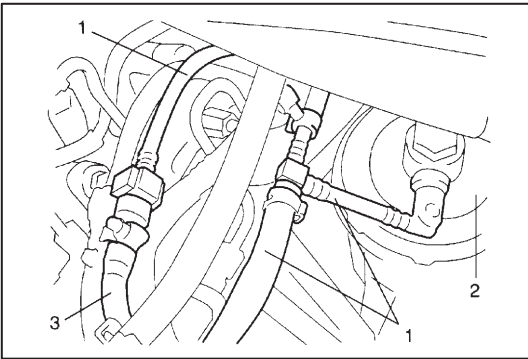

- 6) Remove fuel temperature sensor assembly (1) from common rail.

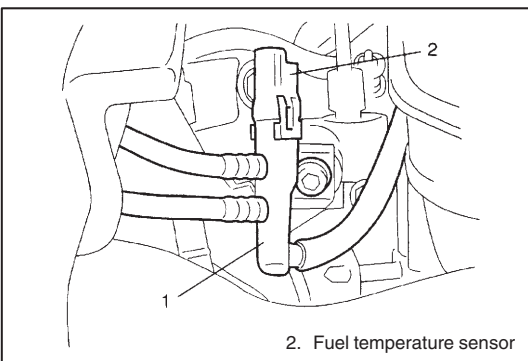

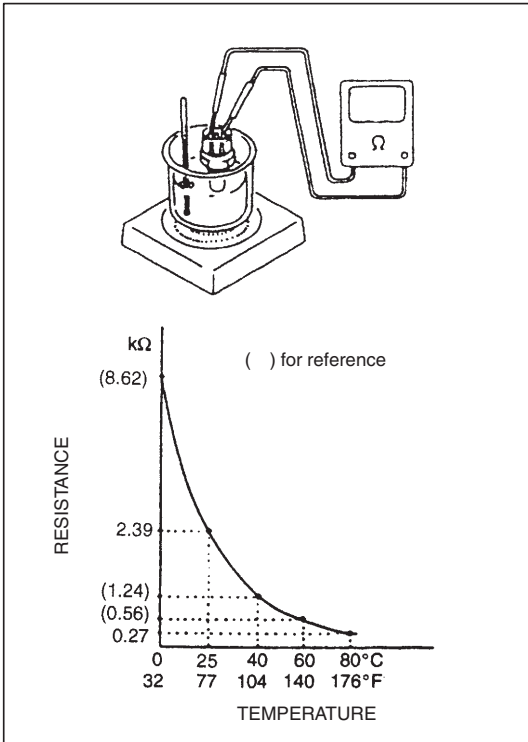

INSPECTION

- 1) Disconnect negative cable at battery.
- 2) Remove intercooler referring to "INTERCOOLER" in this section.
- 3) Remove fuel temperature sensor from its assembly.
- 4) Place sensor and a thermometer in water. Heat water gradually and verify that resistance between fuel temperature sensor terminals at following temperatures is as specified.
If not as specified, replace fuel temperature sensor assembly.

Water temperature °C (°F)	Resistance (kΩ)
-40 (-40)	93.63
-20 (-4)	25.76
0 (32)	8.62
25 (77)	2.39
40 (104)	1.24
60 (140)	0.56
80 (176)	0.27
100 (212)	0.14
120 (248)	0.08

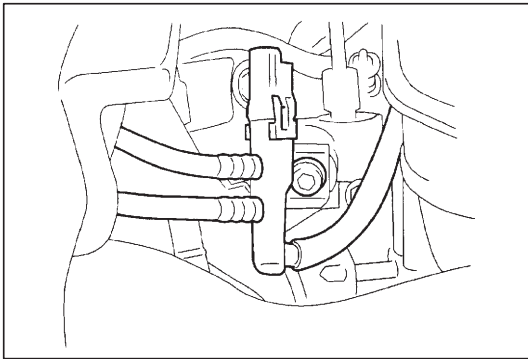

INSTALLATION

For installation, reverse removal procedure noting the following.

- Connect each connector securely.

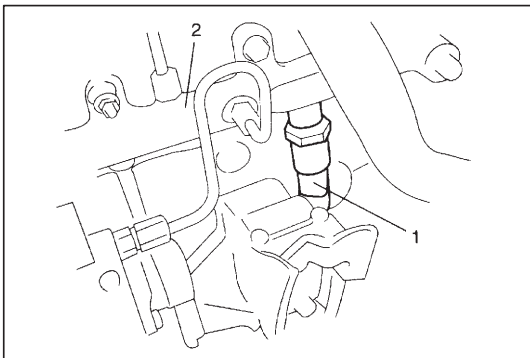

FUEL (RAIL) PRESSURE SENSOR

REMOVAL

- 1) Disconnect negative cable at battery.
- 2) Remove fuel filter assembly referring to Section 6C.
- 3) Disconnect connector from fuel pressure sensor (1).
- 4) Remove fuel pressure sensor from common rail (2).

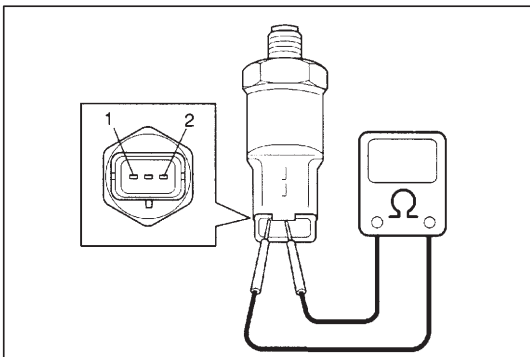

INSPECTION

Measure resistance between sensor terminals (1) and (2).
If resistance is out of specification, replace fuel pressure sensor.
Fuel pressure sensor resistance: about 970 Ω at 20°C (68°F).

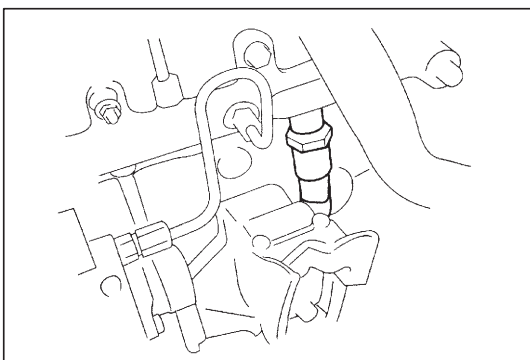

INSTALLATION

Reverse removal procedure for installation.

ENGINE COOLANT TEMPERATURE SENSOR (ECT SENSOR)

REMOVAL

- 1) Disconnect negative cable at battery.
- 2) Drain cooling system.
- 3) Remove intercooler and intercooler outlet hose.

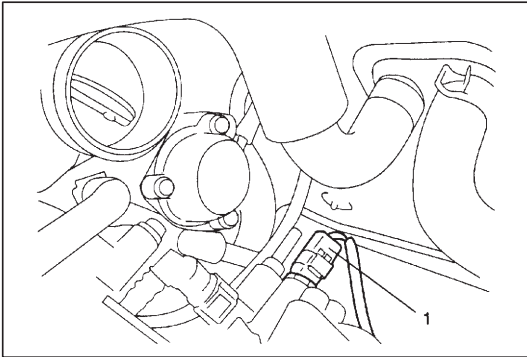

- 4) Disconnect coupler (1) from ECT sensor.
- 5) Remove ECT sensor from water outlet box.

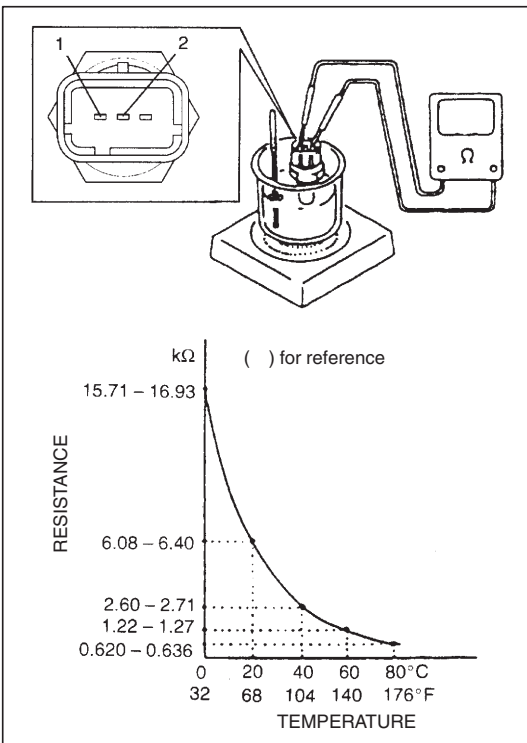

INSPECTION

Immerse temperature sensing part of ECT sensor in water and measure resistance between sensor terminals (1) and (2) while heating water gradually.

If measured resistance doesn't show such characteristic as shown, replace ECT sensor.

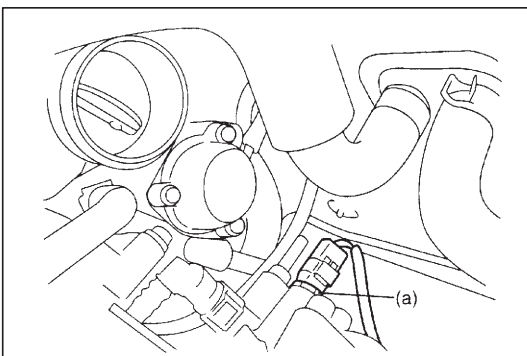

INSTALLATION

Reverse removal procedure noting the following.

- Clean mating surfaces of sensor and water outlet box.
- Check washer for damage and replace ECT sensor if necessary.
- Tighten ECT sensor to specified torque.

Tightening Torque

(a): 17 N·m (1.7 kg-m, 12.5 lb-ft)

- Connect coupler to sensor securely.
- Refill cooling system.

VSS

ON-VEHICLE INSPECTION

Check VSS and its circuits referring to flow table of diagnostic trouble code P0500 in following section.

- For vehicle equipped with single-connector ECM : Section 6
- For vehicle equipped with triple-connector ECM : Section 6-1

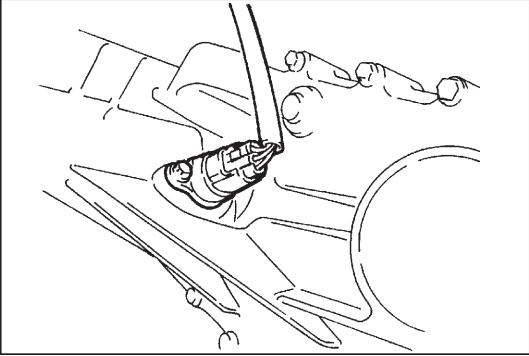

REMOVAL, INSPECTION AND INSTALLATION

Refer to "VSS Removal, Inspection and Installation" in "Transfer" section.

CAMSHAFT POSITION SENSOR (CMP SENSOR)

ON-VEHICLE INSPECTION

Check CMP sensor and its circuits referring to flow table of diagnostic trouble code P0340 in following section.

- For vehicle equipped with single-connector ECM : Section 6
 - For vehicle equipped with triple-connector ECM : Section 6-1
- If malfunction is found, replace.

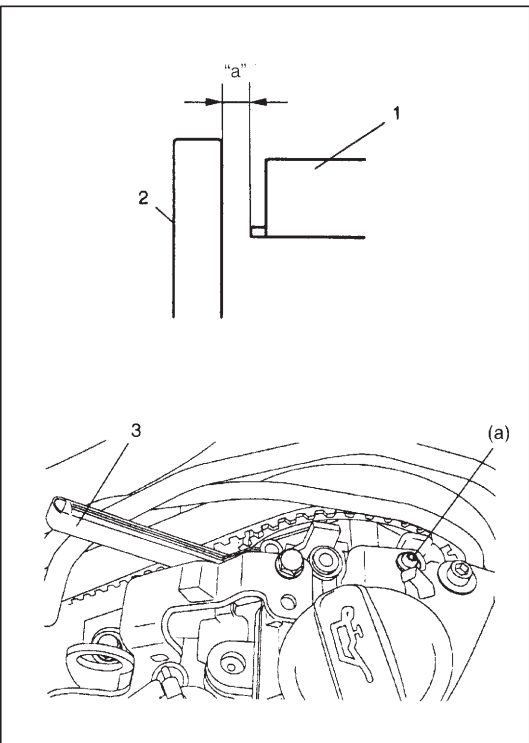

AIR GAP INSPECTION/ADJUSTMENT

- 1) Remove upper timing belt cover.
- 2) Check clearance between CMP sensor (1) and camshaft hub (2), using thickness gauge (3).

Clearance between CMP sensor and camshaft hub

"a": 1.2 mm (0.047 in.)

- 3) If clearance is out of specification, move the CMP sensor and adjust the clearance.

Tightening Torque

CMP sensor bolt (a): 2 N·m (0.2 kg·m, 2.8 lb·ft)

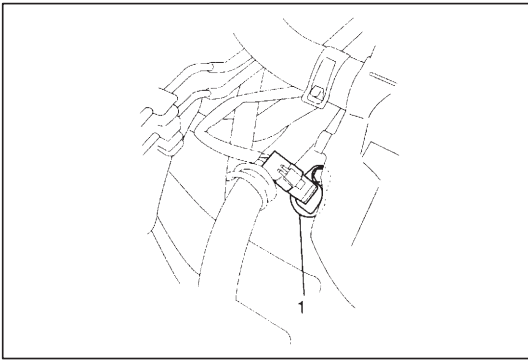

CRANKSHAFT POSITION SENSOR (ENGINE SPEED SENSOR)

REMOVAL

- 1) Remove battery.
- 2) Disconnect connector from crankshaft position sensor.
- 3) Remove crankshaft position sensor (1) from transmission case.

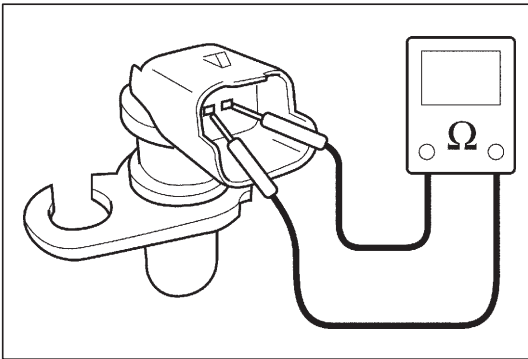

INSPECTION

- Verify that resistance between terminals of CKP sensor is within specification.

Resistance: 315 – 405 Ω

If not as specified, replace CKP sensor.

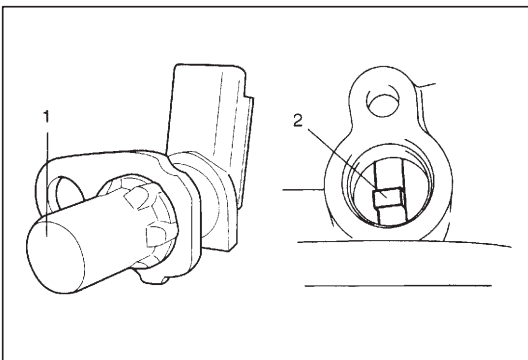

- Check to make sure that crankshaft position sensor (1) and sensor rotor tooth (2) is free from any metal particles and damage.

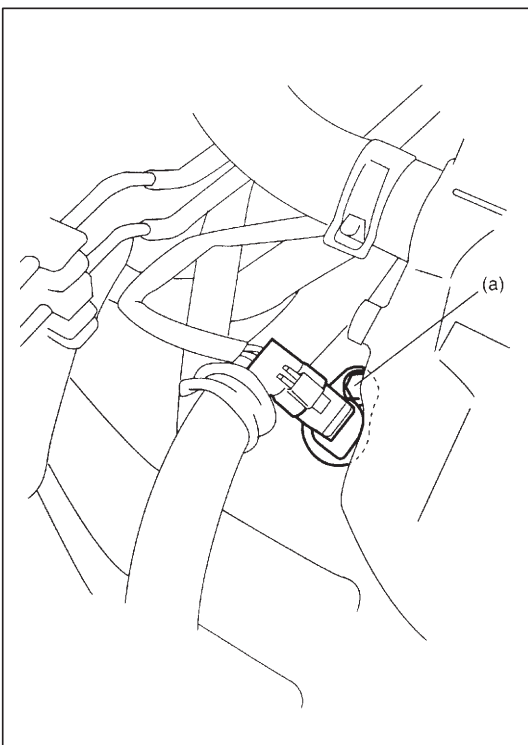

INSTALLATION

- 1) Install crankshaft position sensor to transmission case.

CAUTION:

Be sure to tighten to specified torque, CKP sensor will be deformed if over tightened and correct CKP sensor signal will not be fed if loosened.

- 2) Connect connector to it securely.
- 3) Install battery.

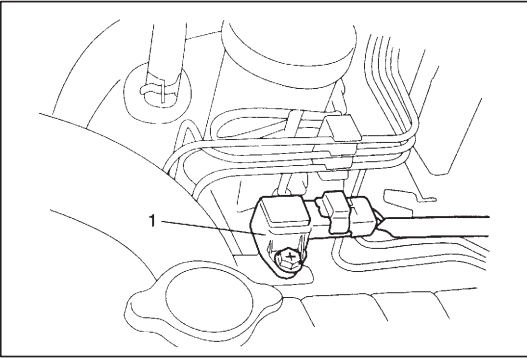

INTAKE AIR PRESSURE SENSOR (MANIFOLD ABSOLUTE PRESSURE SENSOR)

REMOVAL

- 1) Disconnect negative cable at battery.
- 2) Disconnect connector from intake air pressure sensor (1).
- 3) Remove intake air pressure sensor from strut tower bar.

INSPECTION

- 1) Arrange 3 new 1.5 V batteries (2) in series and connect its positive terminal to "Vin" terminal of coupler and negative terminal to "Ground" terminal. Then check voltage between "Vout" and "Ground".

Also, check if voltage reduces when vacuum is slowly applied up to 400 mmHg by using vacuum pump (3).

CAUTION:

As connection to wrong terminal will cause damage to intake air pressure sensor, make absolutely sure to connect properly as shown in left figure.

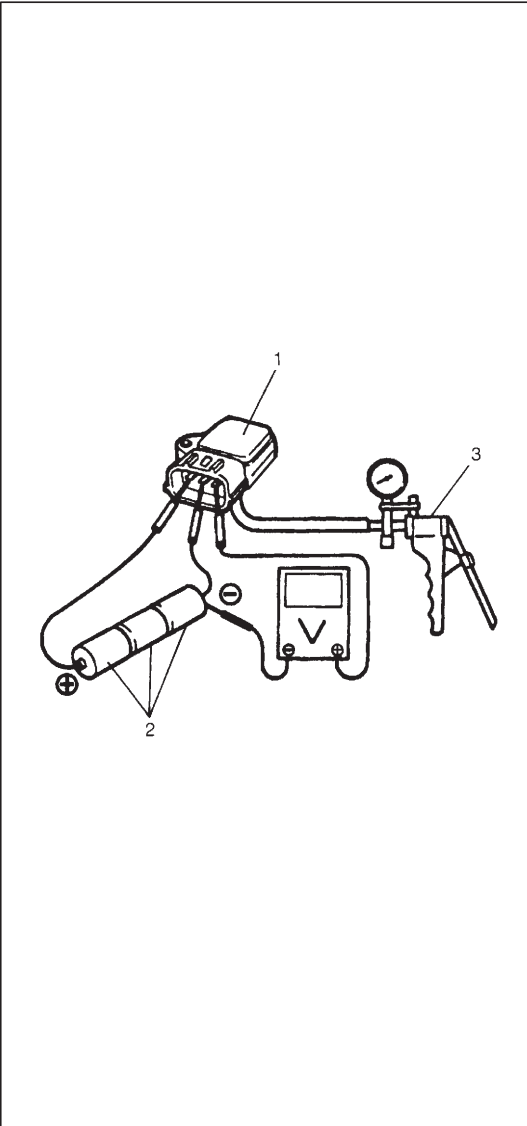

Output voltage (When sensor input voltage is 4.5 – 5.5 V, ambient temp. 20 – 30°C, 68 – 86°F)

ALTITUDE (Reference)		BAROMETRIC PRESSURE		OUTPUT VOLTAGE
(ft)	(m)	(mmHg)	(kPa)	(V)
0 2 000	0 610	760 707	100 94	1.9 – 2.7
2 001 5 000	611 1 524	Under 707 over 634	94 85	1.8 – 2.6
5 001 8 000	1 525 2 438	Under 634 over 567	85 76	1.7 – 2.4
8 001 10 000	2 439 3 048	Under 567 over 526	76 70	1.6 – 2.3

If check result is not satisfactory, replace intake air pressure sensor (1).

INSTALLATION

CAUTION:

Before installing intake air pressure sensor hose, degrease connect part of hose and intercooler outlet hose. Otherwise hose may become detached and cause turbo system failure.

- 1) Install intake air pressure sensor (1) to strut tower bar.
- 2) Connect connector and hose to intake air pressure sensor securely.
- 3) Connect negative cable at battery.

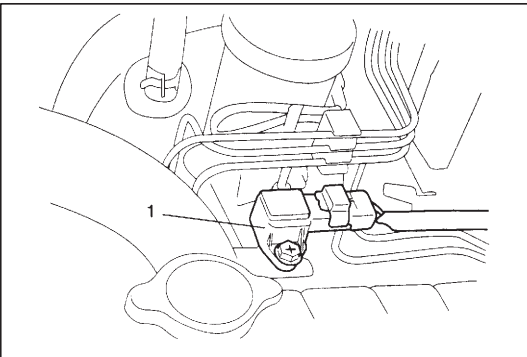

RADIATOR FAN CONTROL SYSTEM

System Inspection

WARNING:

Keep hands, tools, and clothing away from engine cooling fan to help prevent personal injury. This fan is electric and can come on whether or not the engine is running. The fan can start automatically in response to the ECT sensor with the ignition switch in the "ON" position.

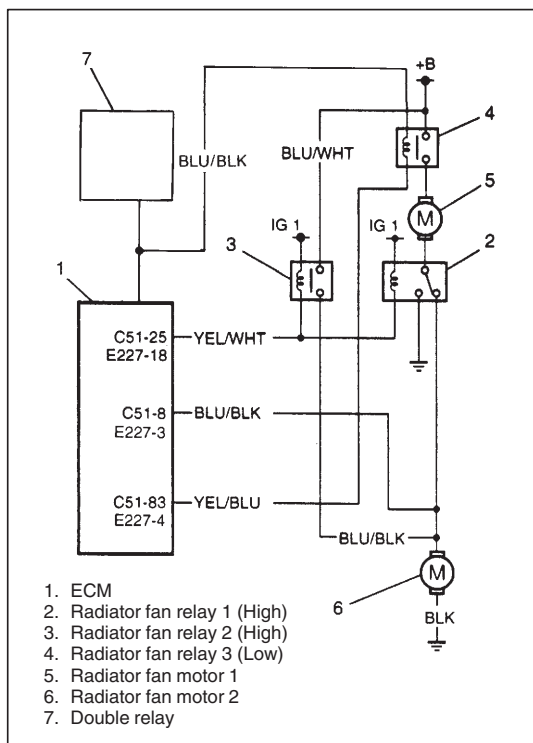

Check system for operation referring to "DTCs P1108, P1109 and P1519 Diag. Flow Table" in following section.

- For vehicle equipped with single-connector ECM : Section 6
 - For vehicle equipped with triple-connector ECM : Section 6-1
- If radiator fan fails to operate properly, check relay, radiator fan and electrical circuit.

Radiator Fan

Inspection

- 1) Check continuity between each two terminals.
If there is no continuity, replace radiator fan motor.

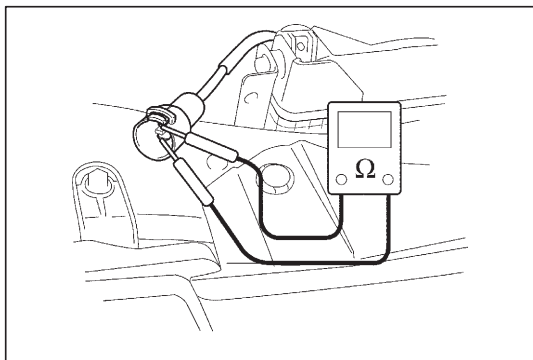

- 2) Connect battery (1) to radiator fan motor coupler (2) (black connector for radiator fan motor 1, white connector for radiator fan motor 2) as shown in figure, then check that the radiator fan motor operates smoothly.
If radiator fan motor does not operate smoothly, replace motor.

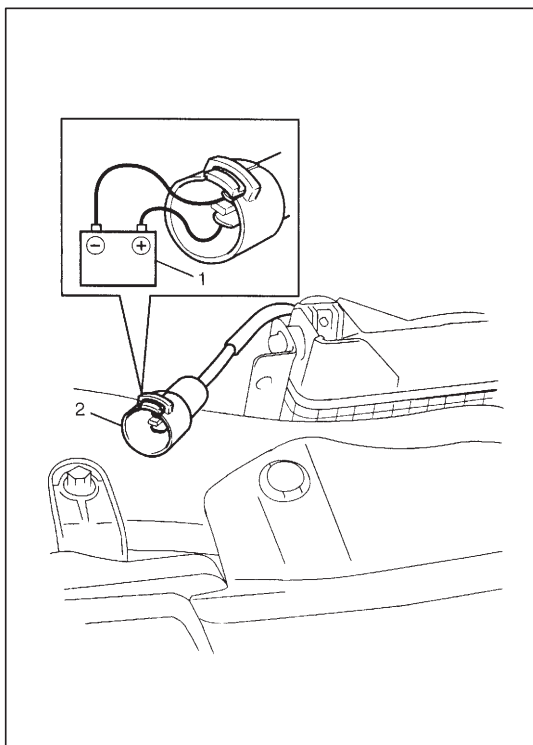

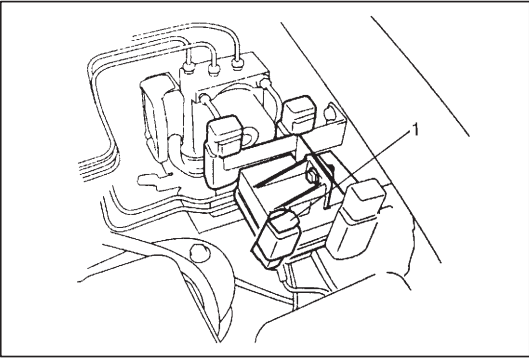

RADIATOR FAN RELAY 1 (High/Low)

Inspection

- 1) Disconnect negative cable at battery.
- 2) Remove radiator fan relay 1 (1) from bracket.

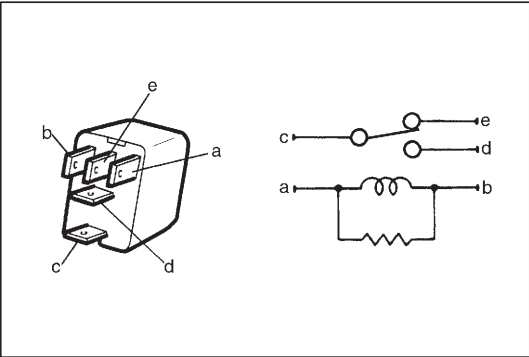

- 3) Check that there is no continuity between terminal "c" and "d". If there is continuity, replace relay.
- 4) Connect battery positive (+) terminal to terminal "b" of relay. Connect battery negative (-) terminal "a" of relay. Check continuity between terminal "c" and "d". If there is no continuity when relay is connected to the battery, replace relay.

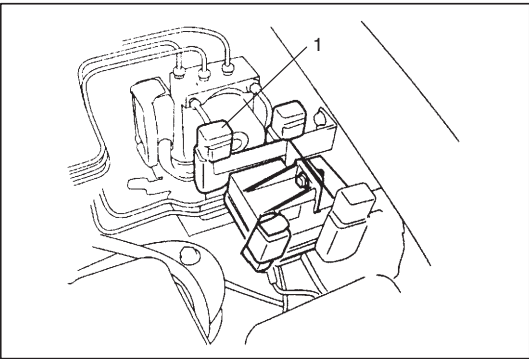

RADIATOR FAN RELAY 2 (High)

Inspection

- 1) Disconnect negative cable at battery.
- 2) Remove radiator fan relay 2 (1) from bracket.

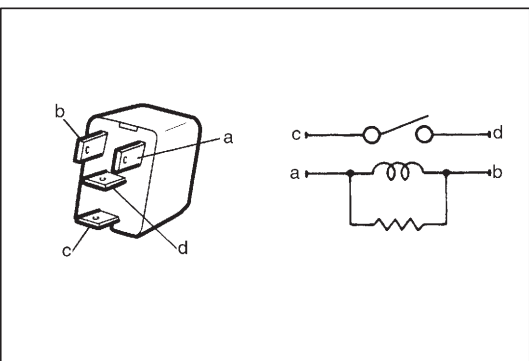

- 3) Check that there is no continuity between terminal "c" and "d". If there is continuity, replace relay.
- 4) Connect battery positive (+) terminal to terminal "b" of relay. Connect battery negative (-) terminal "a" of relay. Check continuity between terminal "c" and "d". If there is no continuity when relay is connected to the battery, replace relay.

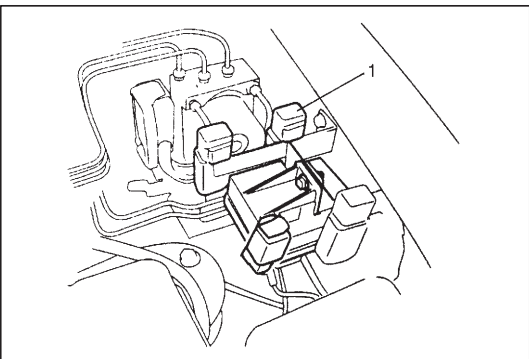

RADIATOR FAN RELAY 3 (Low)

Inspection

- 1) Disconnect negative cable at battery.
- 2) Remove radiator fan relay 3 (1) from bracket.

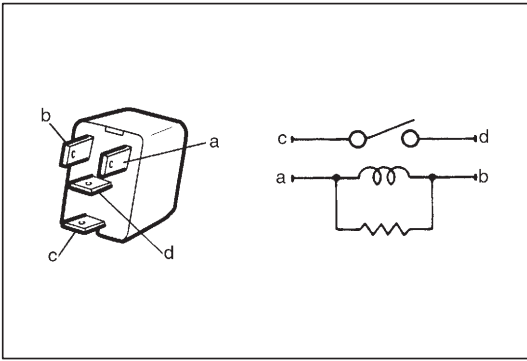

- 3) Check that there is no continuity between terminal "c" and "d".
If there is continuity, replace relay.
- 4) Connect battery positive (+) terminal to terminal "b" of relay.
Connect battery negative (-) terminal "a" of relay.
Check continuity between terminal "c" and "d".
If there is no continuity when relay is connected to the battery,
replace relay.

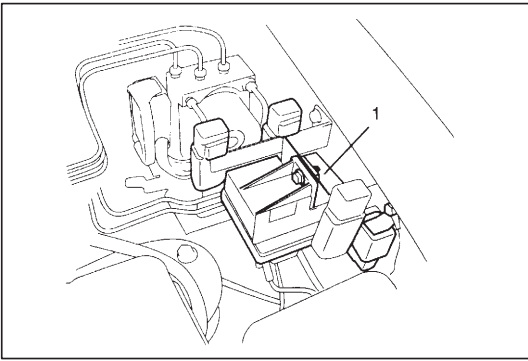

DOUBLE RELAY

REMOVAL

- 1) Disconnect negative cable at battery.
- 2) Remove double relay (1) from bracket.

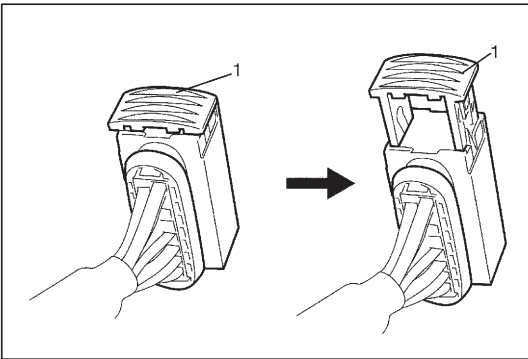

- 3) Disconnect connector from double relay by pulling off lock (1).

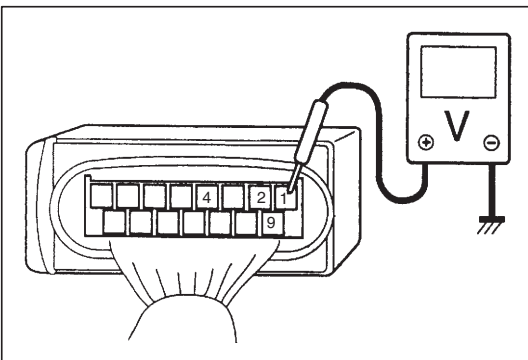

INSPECTION

- 1) Connect connector to double relay.
- 2) Remove "FUEL PUMP" fuse from fuse box.
- 3) Disconnect ECM connector.
- 4) Connect negative cable at battery.
- 5) Check voltage between each terminal and ground.
If not as specified, replace double relay.

Terminal "1", "2", "4" and "9": 0 V

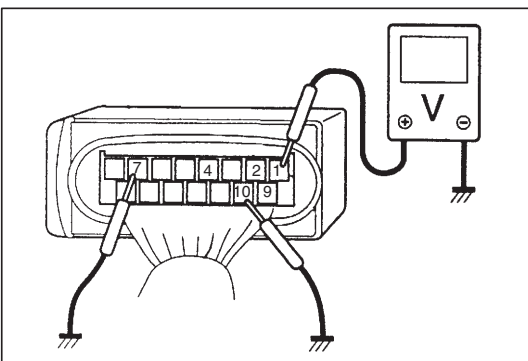

- 6) Using service wire, ground terminal "7" and terminal "10".
- 7) Check voltage between each terminal and ground.
If not as specified, replace double relay.

Terminal "1", "2", "4" and "9": Battery voltage

INSTALLATION

Reverse removal procedure for installation.

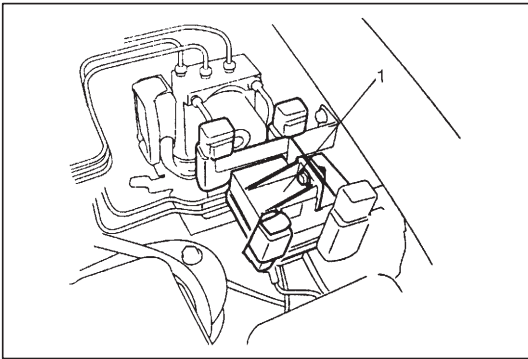

PRE POST HEATING RELAY (CONTROL UNIT)

REMOVAL

- 1) Disconnect negative cable at battery.
- 2) Remove pre post heating control unit (1) from bracket.

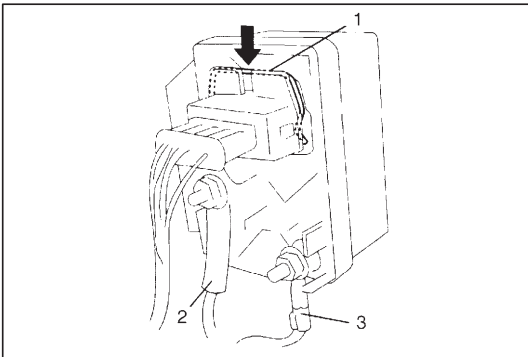

- 3) Disconnect connector from pre post heating control unit by pushing lock (1).
- 4) Disconnect "WHT" wire terminal (2) and "BLK" wire terminal (3).

INSTALLATION

Reverse removal procedure for installation.

EGR SYSTEM

VACUUM HOSE

INSPECTION

Check hose for connection, leakage, clogs and deterioration. Replace as necessary.

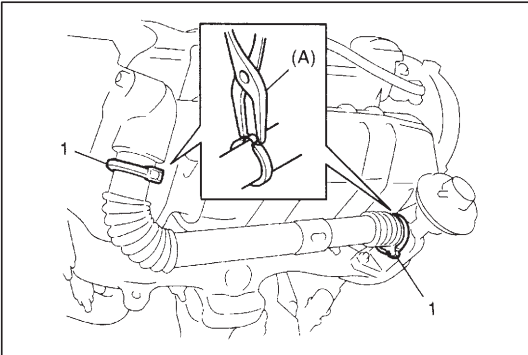

EGR VALVE

REMOVAL

- 1) Remove air cleaner outlet hose from turbocharger and MAF sensor.
- 2) Remove EGR pipe clamps (1) by using special tool.

Special Tool

(A): 09919-46510/OUT0000110

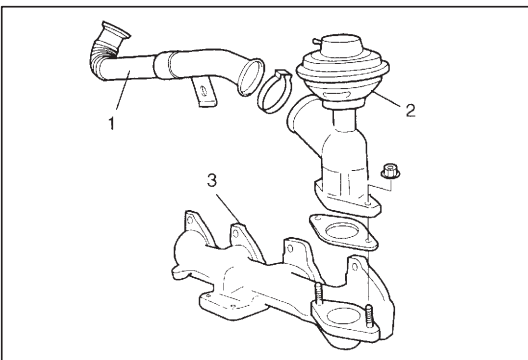

- 3) Remove EGR pipe (1) from EGR valve (2) and intake manifold.
- 4) Remove EGR valve from exhaust manifold (3).

INSPECTION

- 1) Using a vacuum pump, apply vacuum to diaphragm chamber. Check for airflow between ports "A" and "B".

Vacuum: About 24 kPa (180 mmHg) less than:

No airflow

Vacuum other than above:

Airflow

Special Tool

(A): 09917-47910

If not as specified, replace EGR valve.

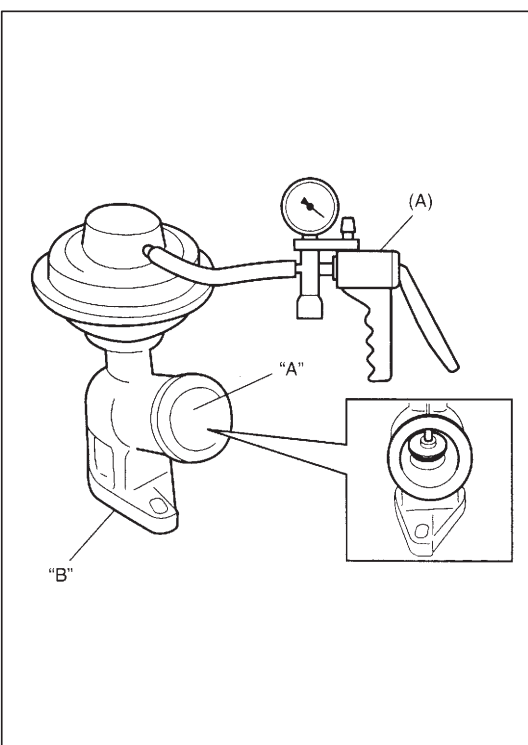

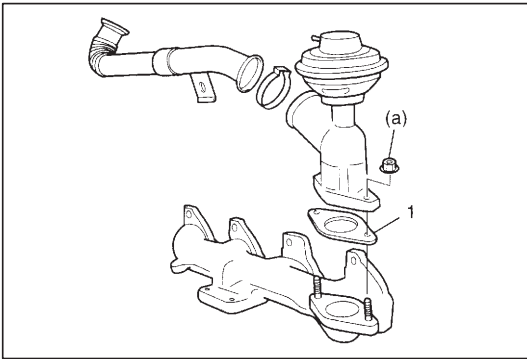

INSTALLATION

For installation, reverse removal procedure noting the following.

- Clean mating surfaces of EGR valve and exhaust manifold.
- Use new gasket (1).
- Tighten EGR valve nuts to specified torque.

Tightening Torque

EGR valve nut (a): 10 N·m (1.0 kg-m, 7.5 lb-ft)

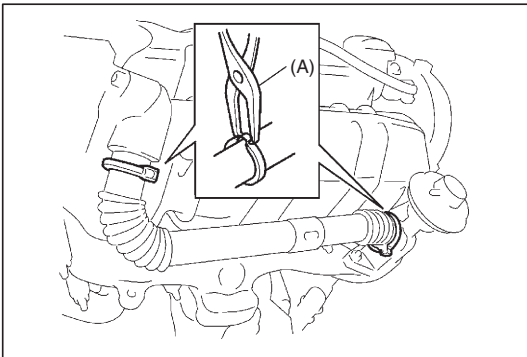

- Install EGR pipe clamps by using special tool.

Special Tool

(A): 09919-46510/OUT0000110

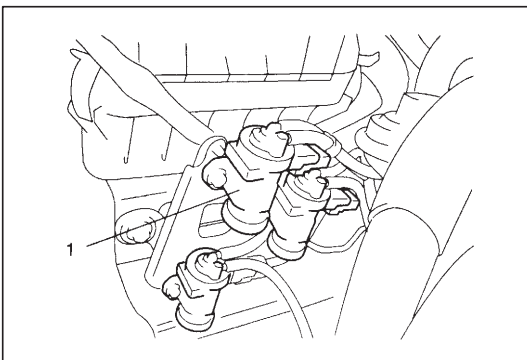

EGR SOLENOID VALVE

REMOVAL

- 1) Disconnect negative cable at battery.
- 2) Remove air cleaner outlet hose.
- 3) Disconnect connector from EGR solenoid valve (1).
- 4) Disconnect vacuum hoses from EGR solenoid valve.
- 5) Remove EGR solenoid valve from bracket.

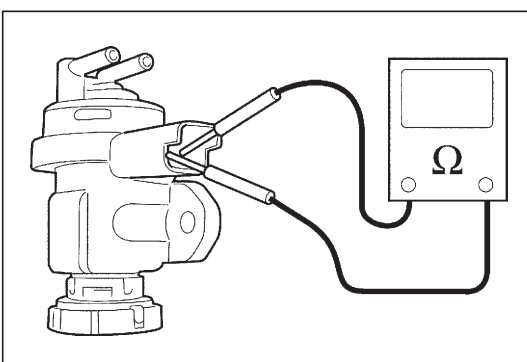

INSPECTION

Measure resistance between each two terminals.

If resistance is out of specification, replace EGR solenoid valve.

EGR solenoid valve resistance: 15 – 20 Ω

INSTALLATION

For installation, reverse removal procedure.

TIGHTENING TORQUE SPECIFICATIONS

Fastening parts	Tightening torque		
	N·m	kg-m	lb-ft
Vacuum pump bolt and nut	20	2.0	14.5
Exhaust manifold nut	25	2.5	18.0
Turbocharger nut	25	2.5	18.0
Turbocharger outlet pipe bolt and nut	30	3.0	22.0
Lubrication pipe union bolt	20	2.0	14.5
Glow plug	10	1.0	7.5
Fuel injector clamp stud bolt	7.5	0.8	5.5
Fuel injector clamp nut	30	3.0	22.0
High pressure pipe union nut	20	2.0	14.5
Common rail bolt	25	2.5	18.0
High pressure supply pipe union nut	20	2.0	14.5
Injection pump bracket bolt	20	2.0	14.5
Injection pump nut and bolt	22.5	2.3	16.5
Injection pump pulley nut	50	5.0	36.5
ECT sensor	17	1.7	12.5
CMP sensor bolt	2	0.2	2.8
EGR valve nut	10	1.0	7.5

SPECIAL TOOLS

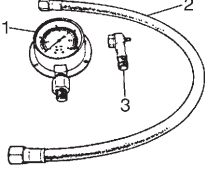
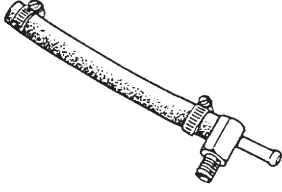
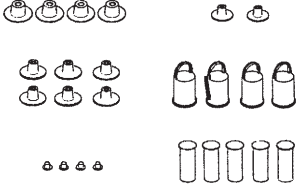
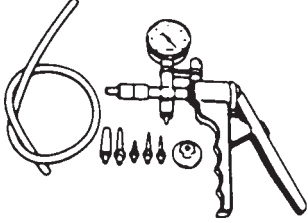
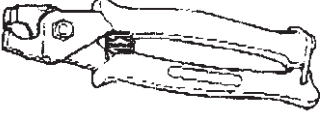
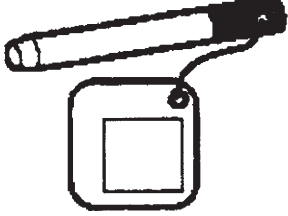
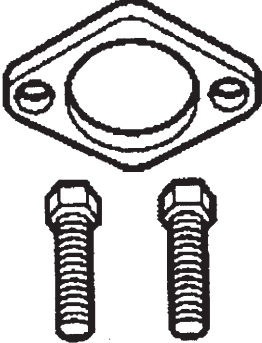
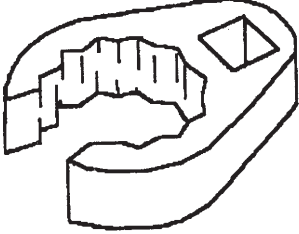
 <p>1. 09912-58441 Pressure gauge 2. 09912-58431 Pressure hose 3. 09912-58450 Attachment</p> <p>09912-58412 Fuel pressure gauge set</p>	 <p>09912-58490 3 way joint and hose</p>	 <p>09916-50010 Fuel system, plug set</p>	
 <p>09917-47910 Vacuum pump gauge</p>	 <p>09919-46510 (OUT0000110) Clamp pliers</p>	 <p>09919-56570 (OUT0000157) Injection pump pulley lock</p>	 <p>09919-56580 (OUT0000158) Injection pump pulley remover</p>
 <p>09950-76510 (OUT0000148) Pipe spanner</p>			

SECTION 6G

CRANKING SYSTEM

(2.0 kW Reduction Type)

NOTE:

For the descriptions (items) not found in this section, refer to the same section of the Service Manual mentioned in FOREWORD of this manual.

CONTENTS

GENERAL DESCRIPTION	6G- 2
Cranking Circuit	6G- 2
Starting Motor Circuit	6G- 2
Starting Motor	6G- 3
DIAGNOSIS	6G- 4
UNIT REPAIR OVERHAUL	6G- 5
Dismounting and Remounting	6G- 5
Disassembly and Reassembly	6G- 5
Inspection	6G- 6
Performance Test	6G- 9
Pull-in test	6G- 9
Hold-in test	6G- 9
Plunger and pinion return test	6G- 9
No-load performance test	6G- 9
SPECIFICATIONS	6G-10
REQUIRED SERVICE MATERIAL	6G-10
TIGHTENING TORQUE SPECIFICATIONS	6G-10

GENERAL DESCRIPTION

CRANKING CIRCUIT

The cranking circuit consists of the battery, starting motor, ignition switch, and related electrical wiring. These components are connected electrically.

Only the starting motor will be covered in this section.

STARTING MOTOR CIRCUIT

- The magnetic switch coils are magnetized when the ignition switch is closed.
- The resulting plunger and pinion drive lever movement causes the pinion to engage the engine flywheel gear and the magnetic switch main contacts to close, and cranking takes place.
- When the engine starts, the pinion over-running clutch protects the armature from excessive speed until the switch is opened, at which time the return spring causes the pinion to disengage.

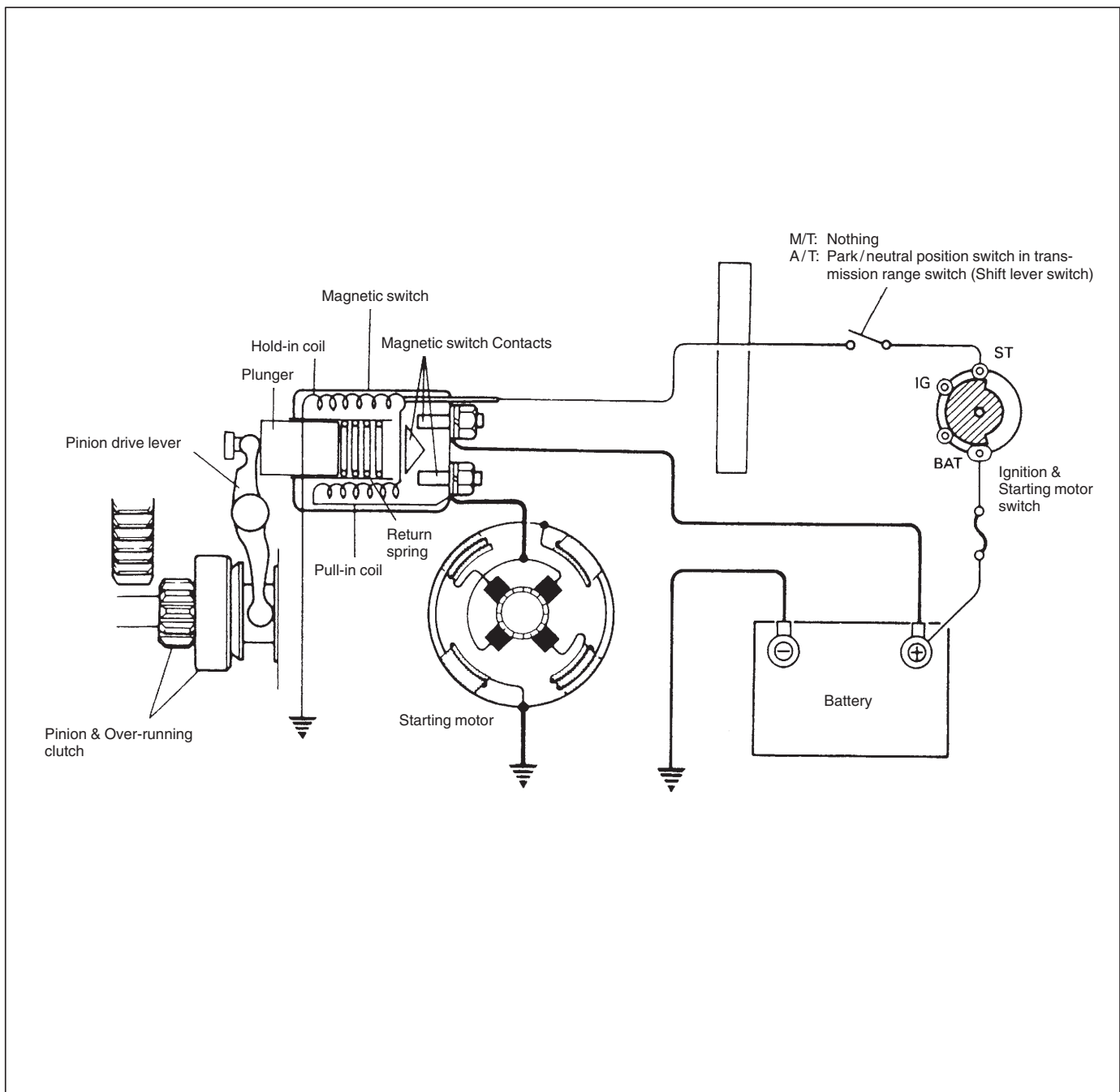

STARTING MOTOR

The starting motor consists of parts shown in below.

The magnetic switch assembly and parts in the starting motor are enclosed in the housings so that they will be protected against possible dirt and water splash.

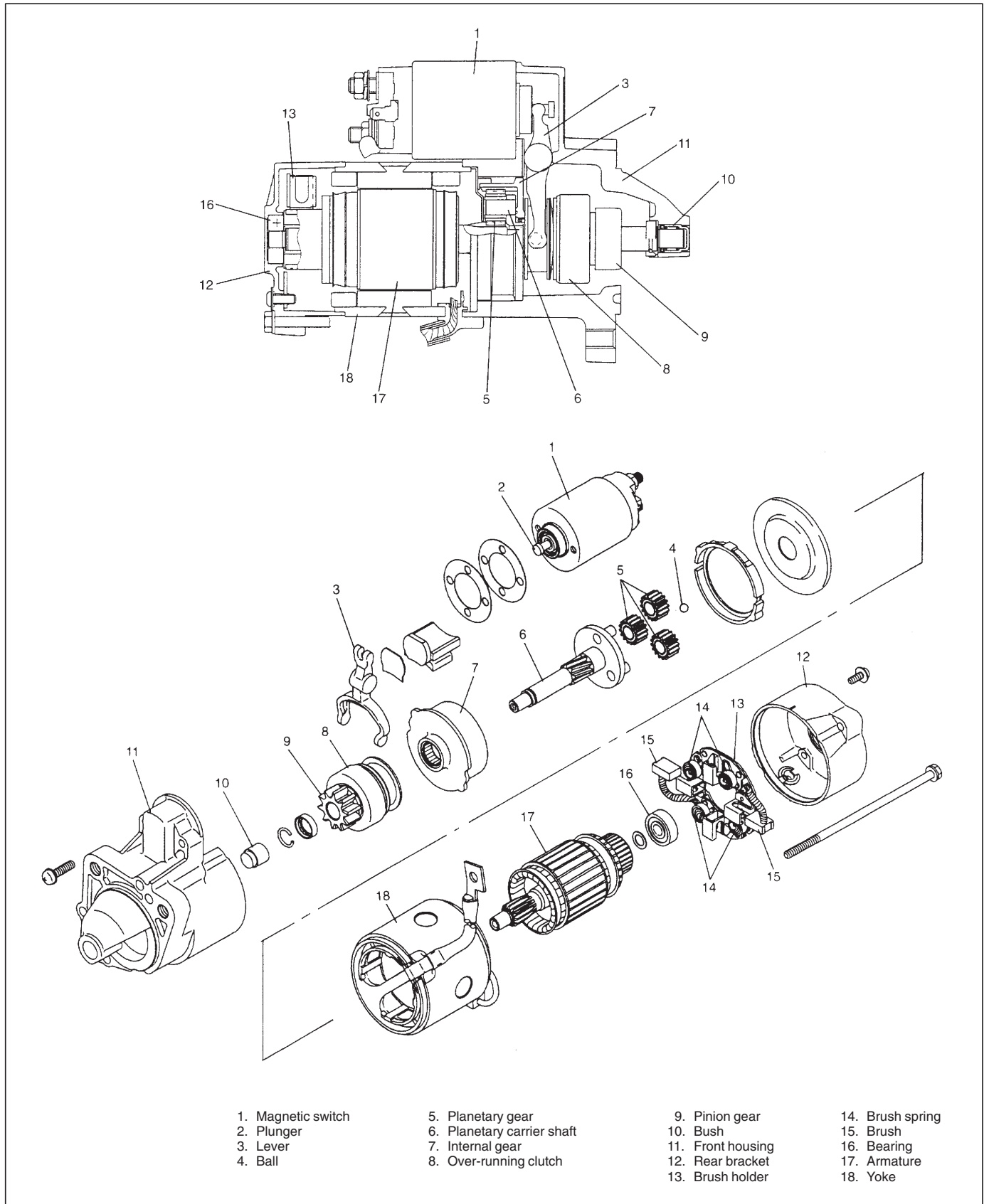

DIAGNOSIS

Condition	Possible Cause	Correction
Motor not running	Operating sound of magnetic switch heard <ul style="list-style-type: none"> ● Battery run down ● Battery voltage too low due to battery deterioration ● Loose battery cable connections ● Burnt main contact point, or poor contacting action of magnetic switch ● Brushes are seating poorly or worn down ● Weakened brush spring ● Burnt commutator ● Poor grounding of field coil ● Layer short-circuit of armature ● Crankshaft rotation obstructed 	Recharge battery. Replace battery. Retighten. Replace magnetic switch. Repair or replace. Replace. Replace armature. Repair. Replace. Repair.
Starting motor running but too slow (small torque)	If battery and wiring are satisfactory, inspect starting motor <ul style="list-style-type: none"> ● Insufficient contact of magnetic switch main contacts ● Layer short-circuit of armature ● Disconnected, burnt or worn commutator ● Poor grounding of field coil ● Worn brushes ● Weakened brush springs ● Burnt or abnormally worn end bush 	Replace magnetic switch. Replace. Repair commutator or replace armature. Repair. Replace brush. Replace spring. Replace bush.

UNIT REPAIR OVERHAUL DISMOUNTING AND REMOUNTING

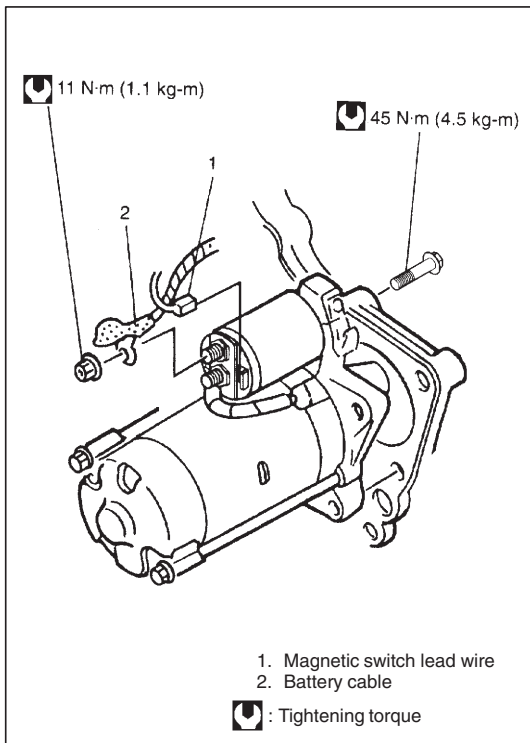

- 1) Disconnect negative cable at battery.
- 2) Disconnect magnetic switch lead wire (“S” terminal) and battery cable from starting motor terminal (“B” terminal).
- 3) Remove strut tower bar.
- 4) Drain coolant.
- 5) Hoist vehicle.
- 6) Remove water outlet pipe mounting bolts from left side engine mounting.
- 7) Disconnect radiator outlet hose No.1 from water outlet box.
- 8) Remove starting motor mount bolts and remove starting motor.
- 9) To install, reverse the above procedure.

DISASSEMBLY AND REASSEMBLY

NOTE:

- Disassemble in order shown in figure.
- For reassembly, reverse disassembly procedure.
- Tighten bolt and nut to specified torque.
- Upon completion of reassembly, carry out “Performance Test” later in this section.

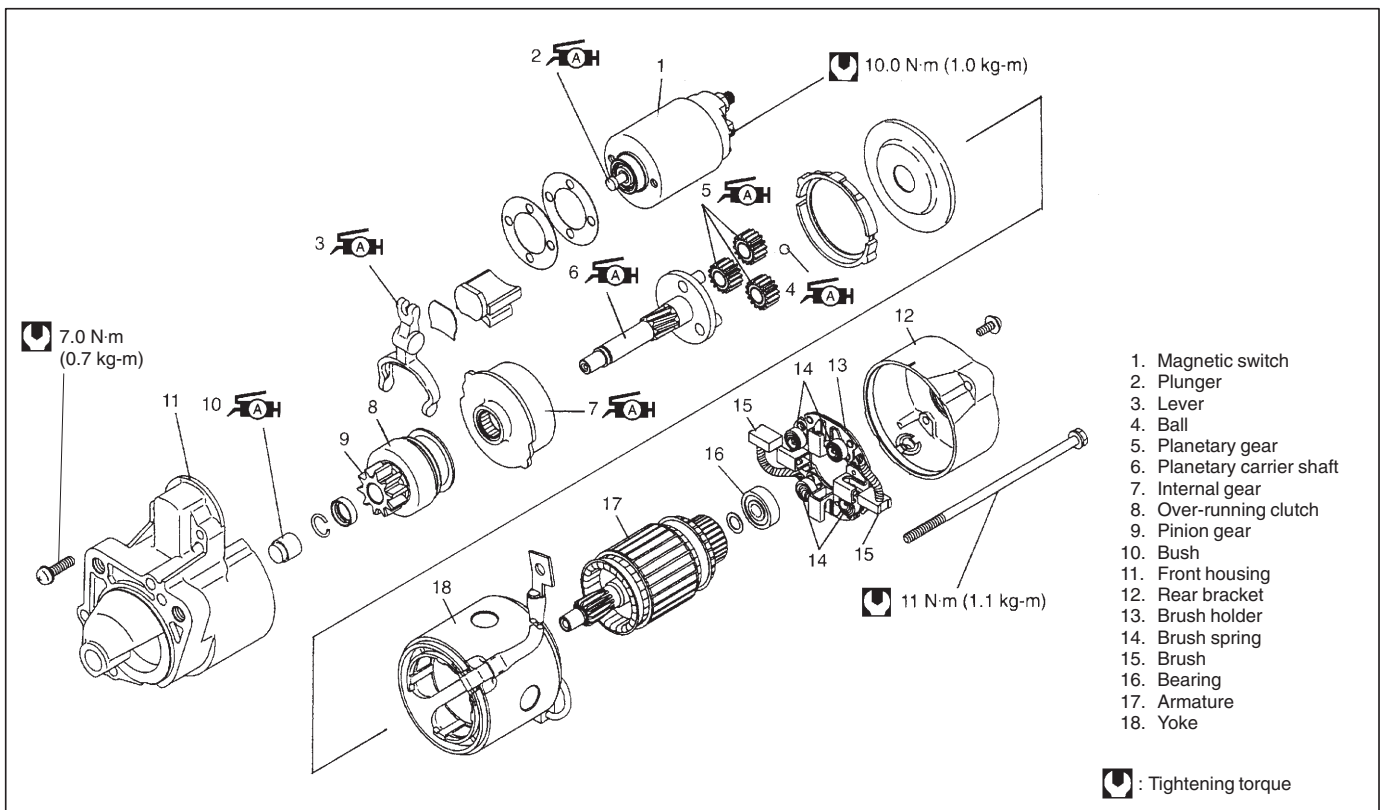

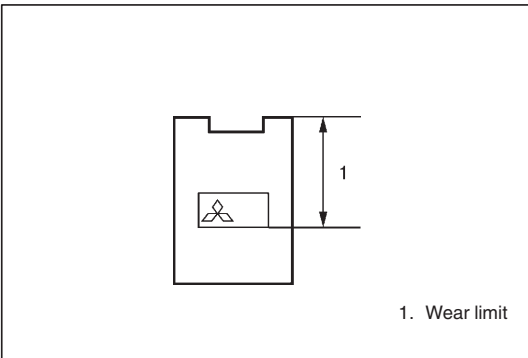

INSPECTION

1. BRUSH

- Check brushes for wear. Measure length of brushes and if below limit, replace brush.

Brush length

Standard	18.0 mm (0.71 in.)
Limit	11.0 mm (0.43 in.)

- Install brushes to each brush holder and check for smooth movement.

2. SPRING

Inspect brush springs for wear, damage or other abnormal conditions. Replace if necessary.

Brush spring tension

Standard	3.1 kg (6.8 lb)
Limit	1.5 kg (3.3 lb)

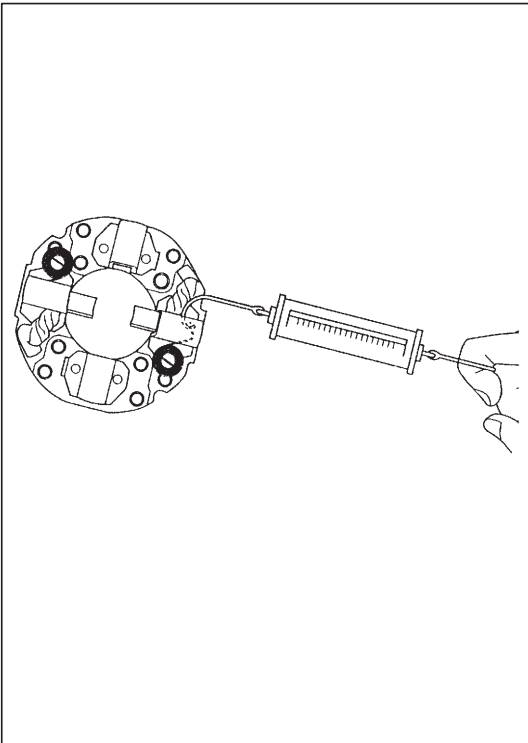

3. BRUSH HOLDER

- Check movement of brush in brush holder. If brush movement within brush holder is sluggish, check brush holder for distortion and sliding faces for contamination. Clean or correct as necessary.
- Check for continuity between insulated brush holder and brush holder plate. Replace brush and brush holder if there is continuity.

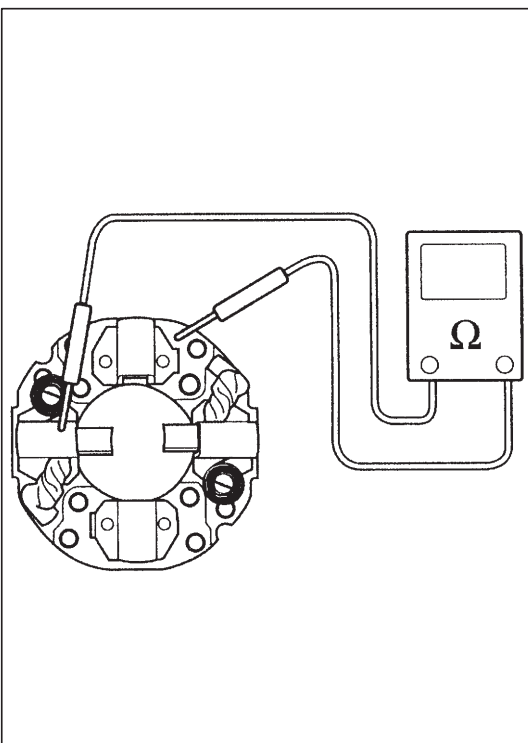

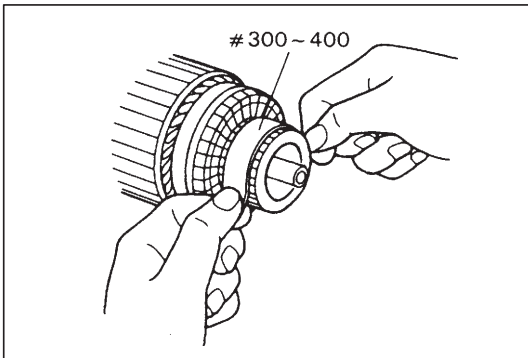

4. ARMATURE

- Inspect commutator for dirt or burn. Correct with sandpaper or lathe, if necessary.

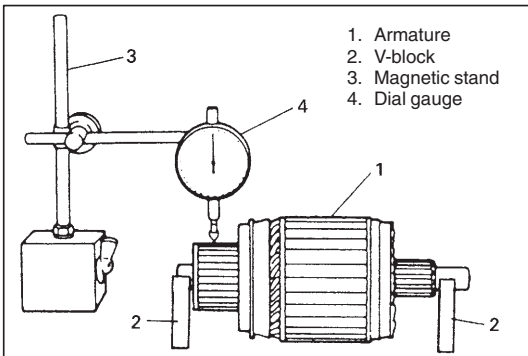

- Check commutator for uneven wear with armature supported on V-blocks. If deflection of dial gauge pointer exceeds limit, repair or replace.

NOTE:

Below specification presupposes that armature is free from bend. Bent armature must be replaced.

Commutator out of round

Standard : 0.05 mm (0.002 in.) or less

Limit : 0.1 mm (0.004 in.)

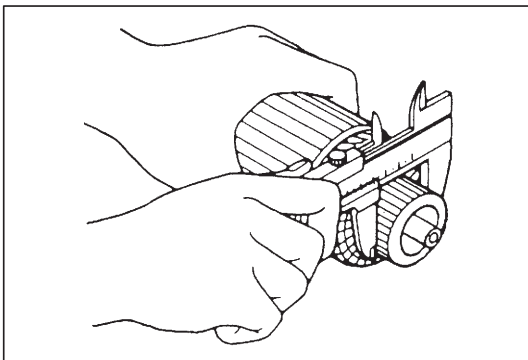

- Inspect commutator for wear. If diameter is below limit, replace armature.

Commutator outside diameter

Limit : 31.4 mm (1.24 in.)

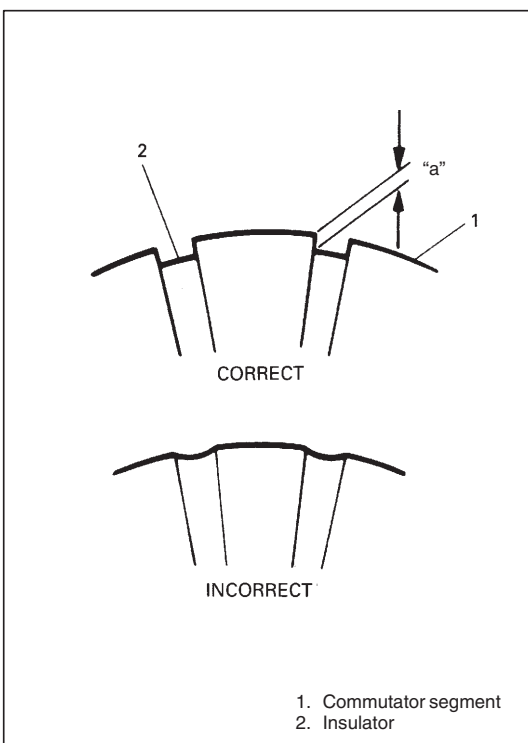

- Inspect commutator for insulator depth. Correct or replace if below limit.

Commutator insulator depth "a"

Standard : 0.5 – 0.8 mm (0.02 – 0.031 in.)

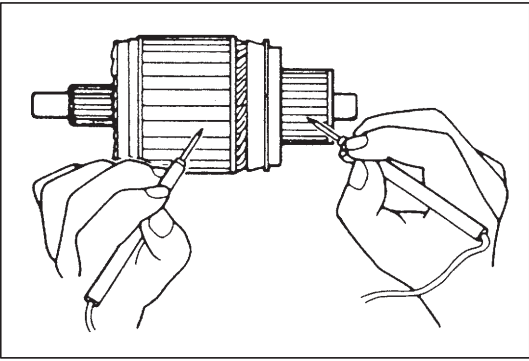

● **Ground Test**

Check commutator and armature core. If there is continuity, armature is grounded and must be replaced.

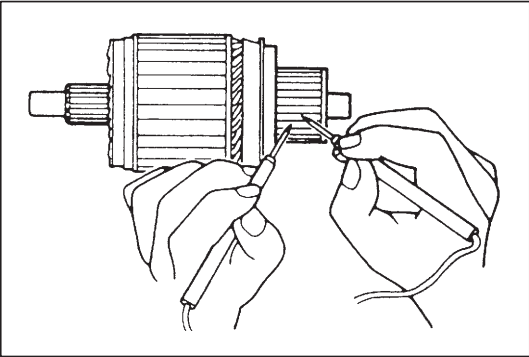

● **Open Circuit Test**

Check for continuity between segments. If there is no continuity at any test point, there is an open circuit and armature must be replaced.

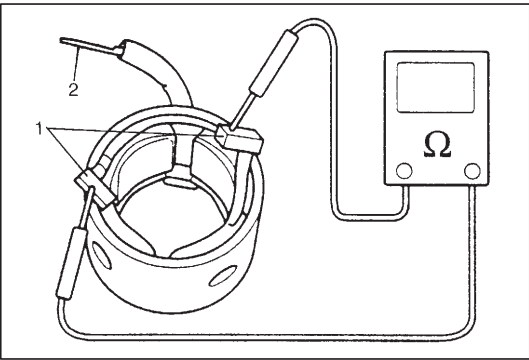

5. FIELD COIL

● Check for continuity between brushes (1) and between connector (2) and brush (1). Replace field coil if there is continuity.

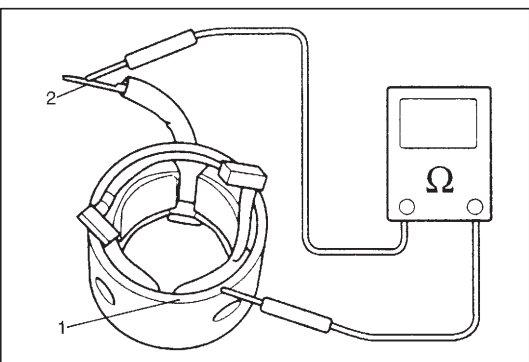

● Check for continuity between connector (2) and yoke (1). Replace field coil if there is continuity.

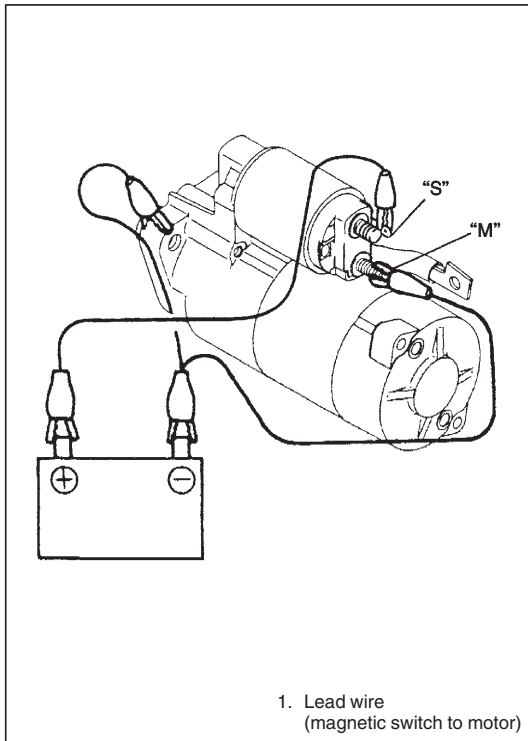

PERFORMANCE TEST

CAUTION:

Each test must be performed within 3 – 5 seconds to avoid coil from burning.

1) Pull-In Test

Connect battery to magnetic switch as shown.
Check that plunger and pinion move outward.
If plunger and pinion don't move, replace magnetic switch.

NOTE:

Before testing, disconnect lead wire from terminal "M".

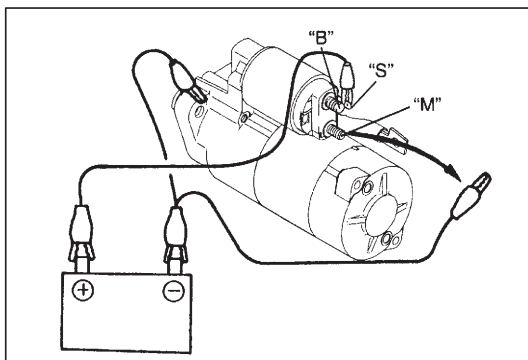

2) Hold-In Test

While connected as above with plunger out, disconnect negative lead from terminal "M".
Check that plunger and pinion remain out.
If plunger and pinion return inward, replace magnetic switch.

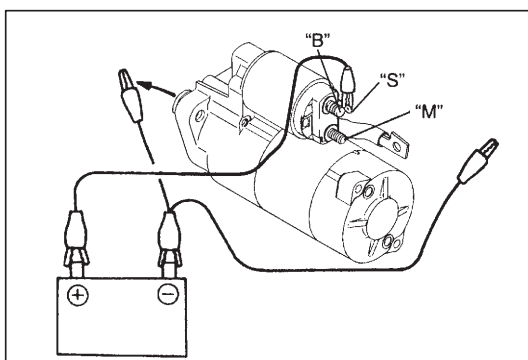

3) Plunger and Pinion Return Test

Disconnect negative lead from switch body.
Check that plunger and pinion return inward.
If plunger and pinion don't return, disassemble and inspect starting motor.

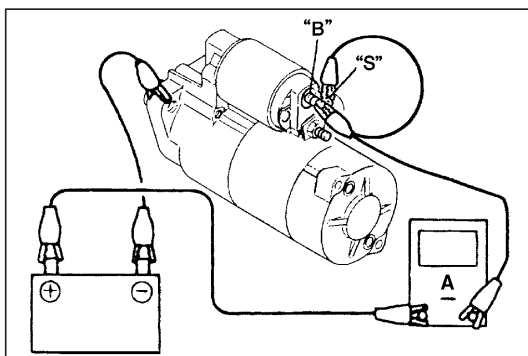

4) No-Load Performance Test

- a) Connect battery and ammeter to starter as shown.
- b) Check that starter rotates smoothly and steadily with pinion moving out. Check that ammeter indicates specified current.

Specified current: 130A MAX. at 11V

NOTE:

Use wires as thick as possible and tighten each terminal fully.

SPECIFICATIONS

2.0 kW Reduction Type

Voltage		12 volts	
Output		2.0 kW	
Rating		30 seconds	
Direction of rotation		Clockwise as viewed from pinion side	
Brush length		18.0 mm (0.71 in.)	
Number of pinion teeth		10	
Performance		Condition	Guarantee
Around at 20 °C (68 °F)	No load characteristic	11.0 V	130 A maximum 3,600 rpm minimum
	Load characteristic	7.7 V 400 A	10.6 N·m (1.06 kg-m, 7.67 lb-ft) minimum 1,280 rpm minimum
	Locked characteristic	3.0 V	1000 A maximum 29.4 N·m (2.94 kg-m, 21.3 lb-ft) minimum
	Magnetic switch operating voltage		8 volts maximum

REQUIRED SERVICE MATERIAL

MATERIAL	RECOMMENDED SUZUKI PRODUCT	USE
Lithium grease	SUZUKI SUPER GREASE A (99000-25010)	<ul style="list-style-type: none"> ● Front bush ● Plunger ● Pinion drive lever ● Internal gear ● Planetary carrier shaft ● Planetary gear ● Ball

TIGHTENING TORQUE SPECIFICATIONS

Fastening parts	Tightening torque		
	N·m	kg-m	lb-ft
Starting motor mounting bolt	45	4.5	32.5
"B" terminal nut	11	1.1	8
Magnetic switch screw	7	0.7	5.0
Starting motor housing screw	11	1.1	8

SECTION 6H

CHARGING SYSTEM

WARNING:

For vehicles equipped with Supplemental Restraint (Air Bag) System

- Service on and around the air bag system components or wiring must be performed only by an authorized SUZUKI dealer. Refer to “Air Bag System Components and Wiring Location View” under “General Description” in air bag system section in order to confirm whether you are performing service on or near the air bag system components or wiring. Please observe all WARNINGS and “Service Precautions” under “On-Vehicle Service” in air bag system section before performing service on or around the air bag system components or wiring. Failure to follow WARNINGS could result in unintentional activation of the system or could render the system inoperative. Either of these two conditions may result in severe injury.
- Technical service work must be started at least 90 seconds after the ignition switch is turned to the “LOCK” position and the negative cable is disconnected from the battery. Otherwise, the system may be activated by reserve energy in the Sensing and Diagnostic Module (SDM).

CONTENTS

ON-VEHICLE SERVICE	6H-2
GENERATOR BELT	6H-2
UNIT REPAIR OVERHAUL	6H-4
GENERATOR	6H-4
DISMOUNTING AND REMOUNTING	6H-4
DISASSEMBLY AND REASSEMBLY	6H-5
SPECIFICATIONS	6H-6
GENERATOR	6H-6
SPECIAL TOOLS	6H-6

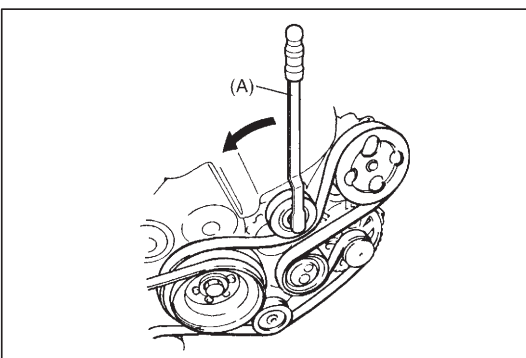
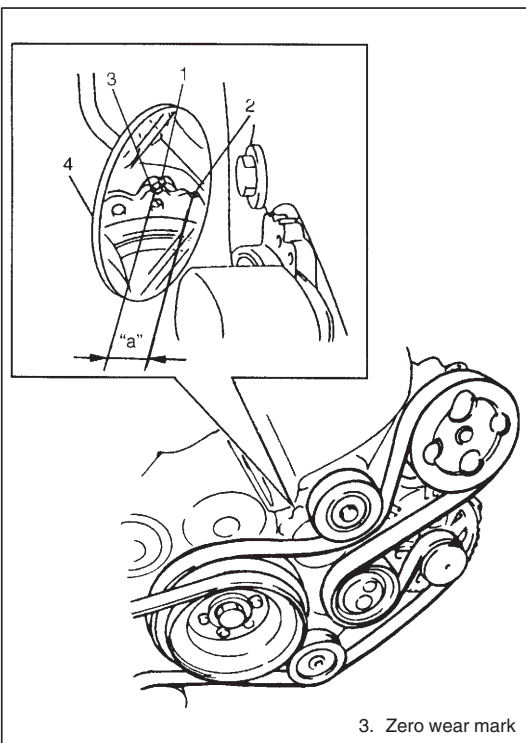
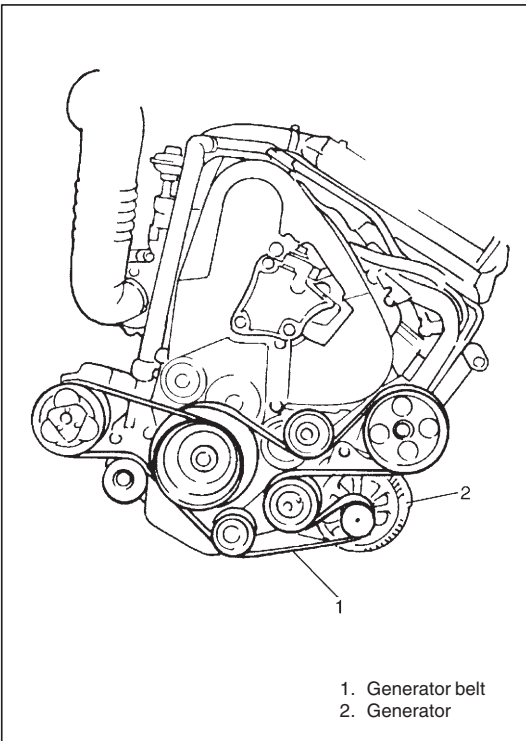

ON-VEHICLE SERVICE

GENERATOR BELT

WARNING:

Disconnect negative cable at battery before inspection, removing and installing Generator belt.

INSPECTION

- Verify that belt engages with pulley groove correctly.
- Visually check for wear and damage on belt and pulley contact surface and damage on pulley.

- Inspect belt for cracks, cuts, deformation, wear and cleanliness using mirror under enough lighting. If any defect exists, replace.
- Check that belt wear check mark (1) (tension indicator) is within range "a" using mirror (4) under enough lighting. If wear check mark (1) is aligned with maximum wear mark (2) or out of range "a", replace generator belt with a new one.

REMOVAL

- 1) Using special tool (A) for dynamic roller tensioner, turn dynamic roller tensioner counterclockwise to loosen it.

Special tool

(A): 09919-56610/OUT0000143

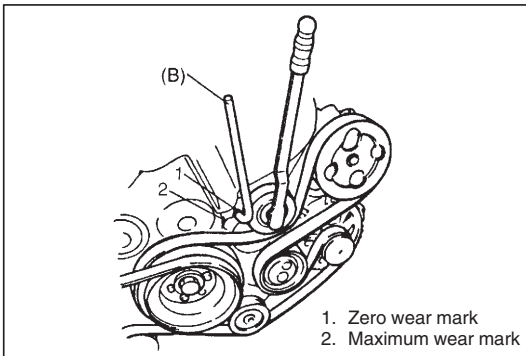

- 2) With dynamic roller tensioner holes aligned by turning dynamic roller tensioner, insert special tool (B) into them.

Special tool

(B): 09919-56590/OUT0000142

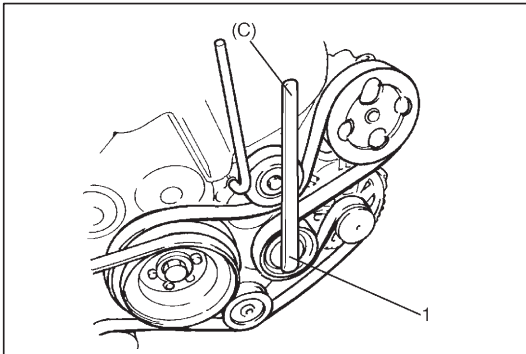

- 3) Loosen roller tensioner bolt (1) using special tool (C).

Special tool

(C): 09919-56620

- 4) Remove generator belt.

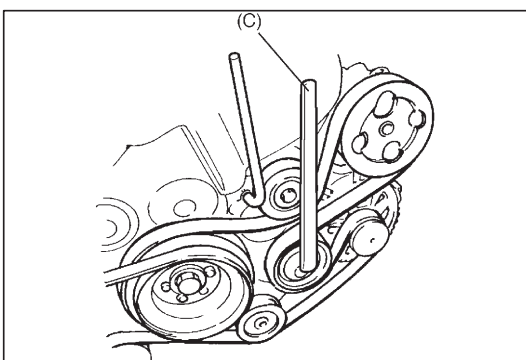

INSTALLATION

- 1) Using special tool (C) for roller tensioner, turn roller tensioner clockwise to loosen it.
- 2) While holding the tensioner, install generator belt.

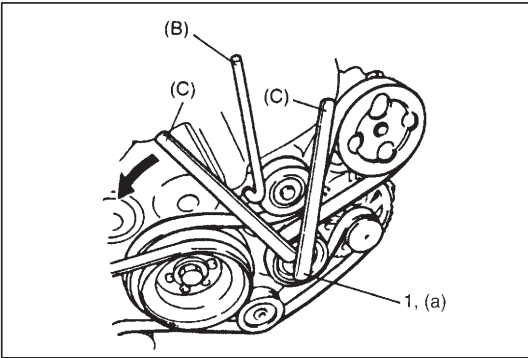

- 3) Using special tool (C), turn roller tensioner counterclockwise to until special tool (B) becomes free. With roller tensioner kept in that state, fix it by tightening roller tensioner bolt (1) to specified torque.

Special tool

(B): 09919-56590/OUT0000142

(C): 09919-56620

Tightening torque

(a): 50 N·m (5.0 kg·m, 36.5 lb·ft)

- 4) Remove special tool (B) and (C), turn crankshaft pulley 4 revolutions.
- 5) Using special tool (B), check that dynamic roller tensioner holes are aligned. If they are not aligned, repeat step 3) to 5).

UNIT REPAIR OVERHAUL

GENERATOR

DISMOUNTING AND REMOUNTING

- Dismount in numerical order indicated in figure.
- For remounting, reverse dismounting procedure.
- Tighten bolt and nut to specified torque.

Tightening Torque

P/S pump mounting bolt: 25 N·m (2.5 kg·m, 18.0 lb·ft)

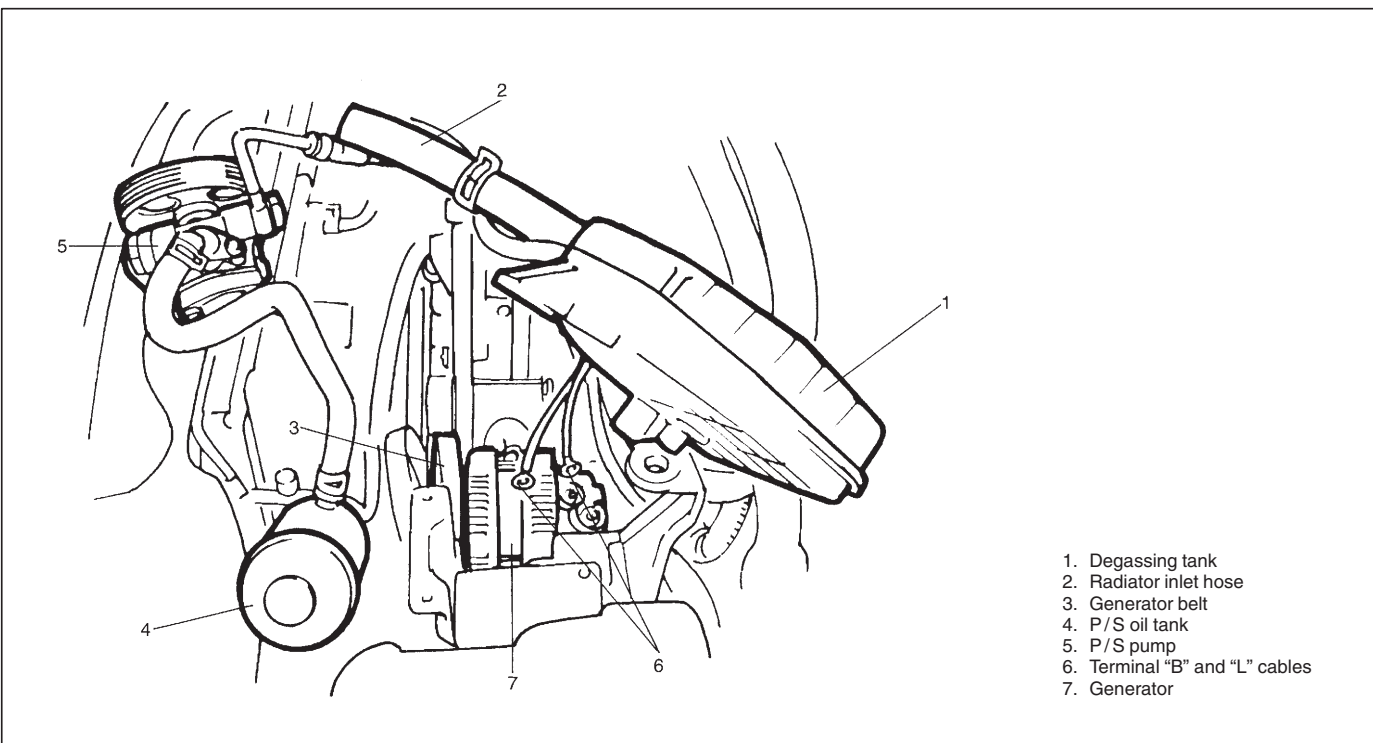

DISASSEMBLY AND REASSEMBLY

- Disassemble in numerical order shown in figure below and note the following.
- For reassembly, reverse disassembly procedure.

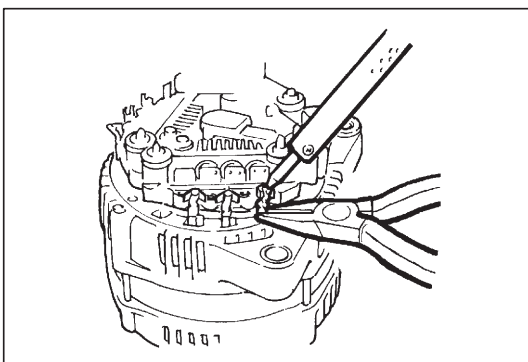
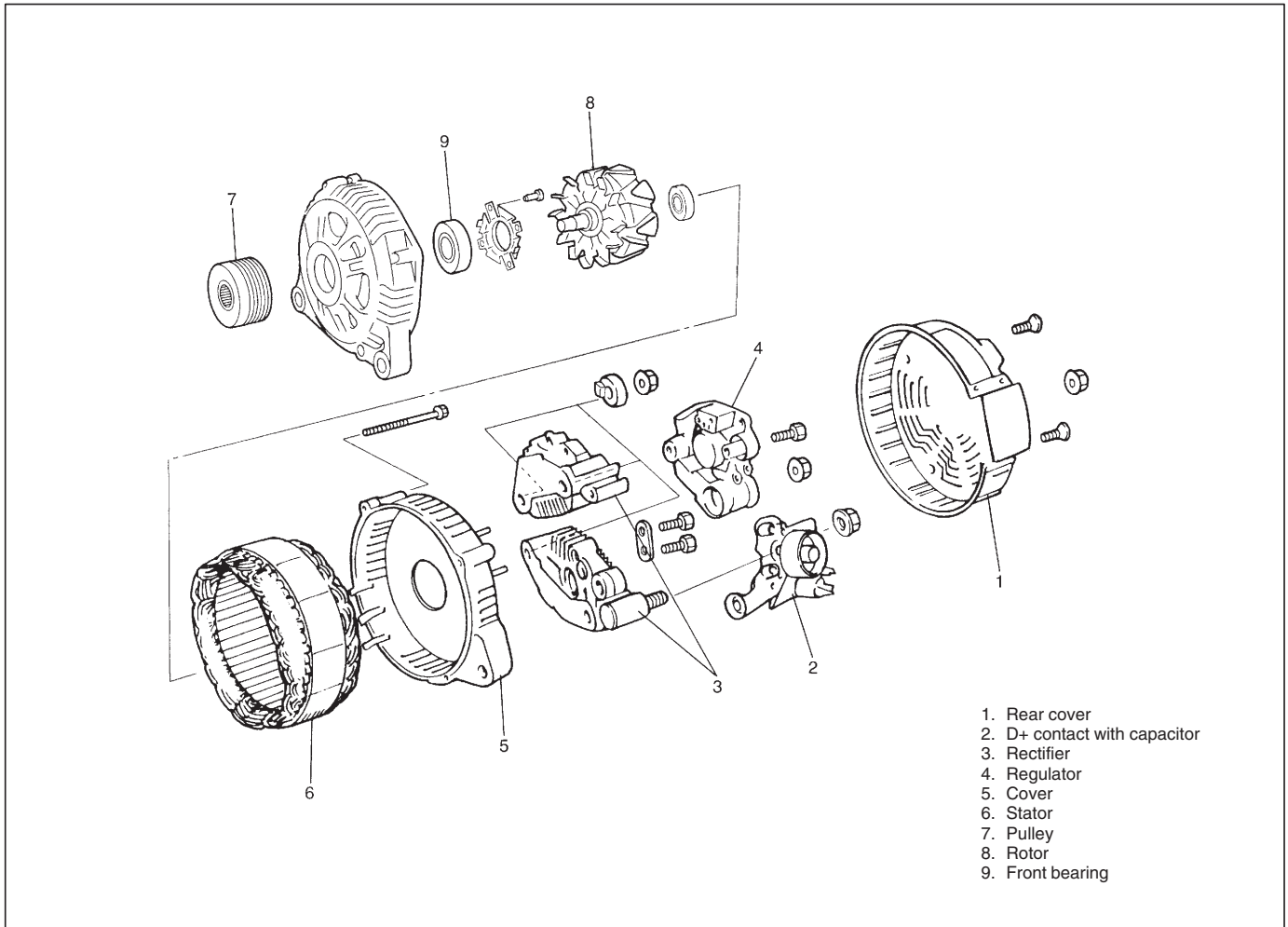

- When removing stator lead wire from rectifier, carry out soldering quickly.

CAUTION:

Overheating can damage semiconductor components such as regulator and rectifier.

NOTE:

Hold lead wire with pliers during soldering to prevent applying heat to rectifier.

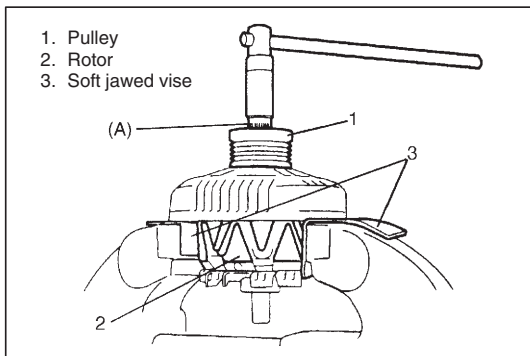

- Hold rotor with soft jawed vise and remove pulley by using special tool.

Special tool



(A): 09932-96510

SPECIFICATIONS

GENERATOR

Type	150 A type
Rated voltage	12 V
Nominal output	150 A

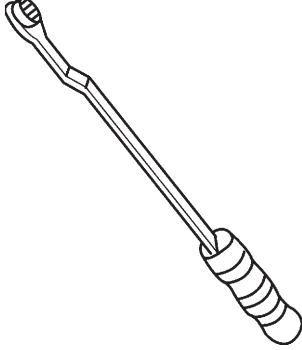
SPECIAL TOOLS

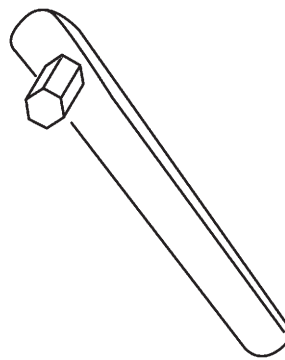
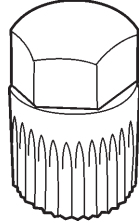
			
<p>09919-56610/OUT0000143 Belt tension lever</p>	<p>09919-56590/OUT0000142 Belt tensioner pin</p>	<p>09919-56620 Belt tension adjuster wrench</p>	<p>09932-96510 Pulley remover attachment</p>

SECTION 6K

EXHAUST SYSTEM

CONTENTS

GENERAL DESCRIPTION	6K-1
MAINTENANCE	6K-2
ON-VEHICLE SERVICE	6K-3

GENERAL DESCRIPTION

The exhaust system consists of an exhaust manifold, a turbo charger, a turbocharger outlet pipe, an exhaust No.1 pipe, an exhaust No.2 pipe, a muffler and seal, gaskets and etc., and the exhaust No.2 pipe has the catalytic converter for oxidation.

The catalytic converter for oxidation is an emission control device added to the exhaust system to lower the levels of Hydrocarbon (HC) and Carbon Monoxide (CO) pollutants in the exhaust gas.

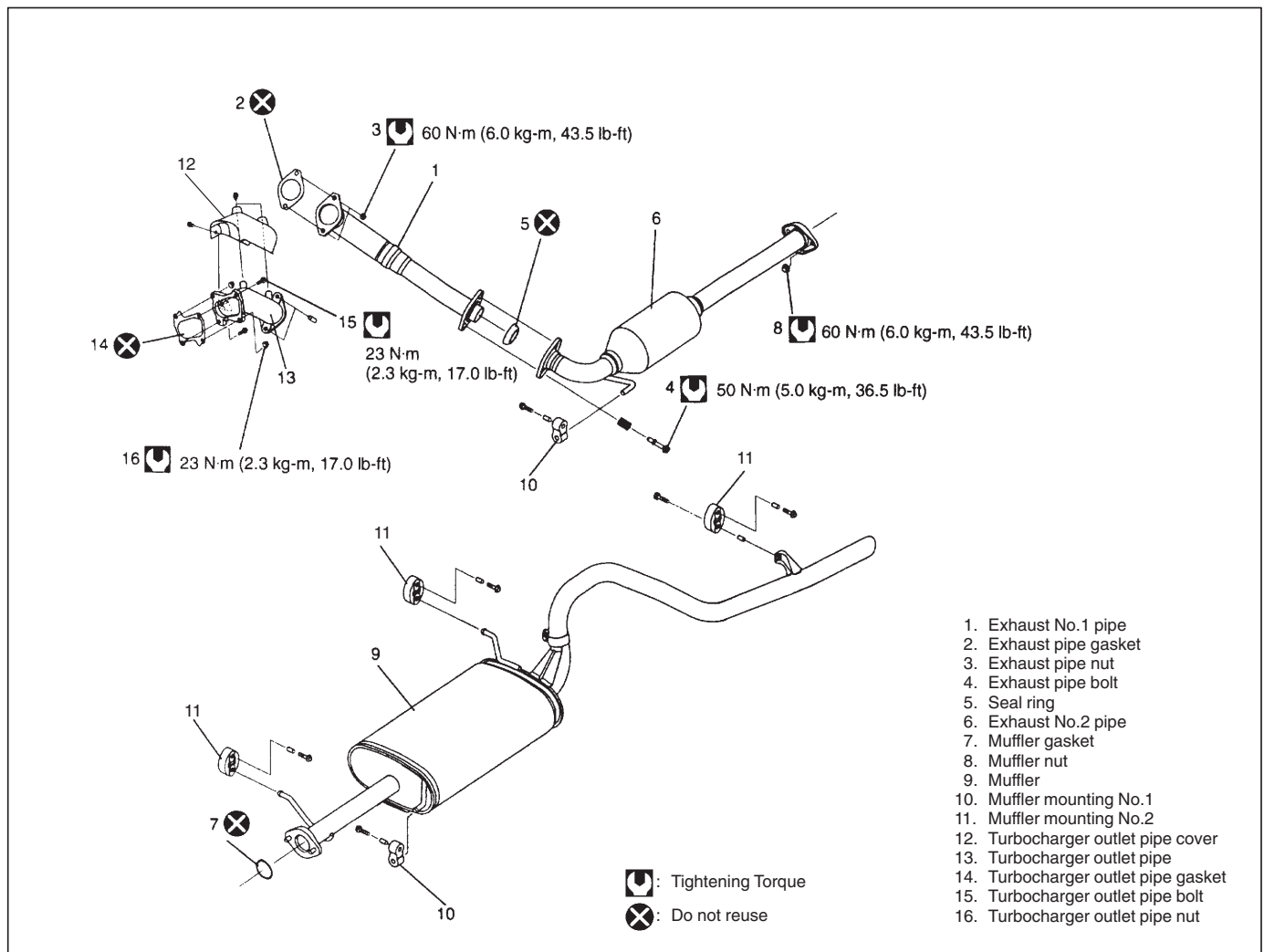

MAINTENANCE

WARNING:

To avoid the danger of being burned, do not touch the exhaust system when the system is hot. Any service on the exhaust system should be performed when the system is cool.

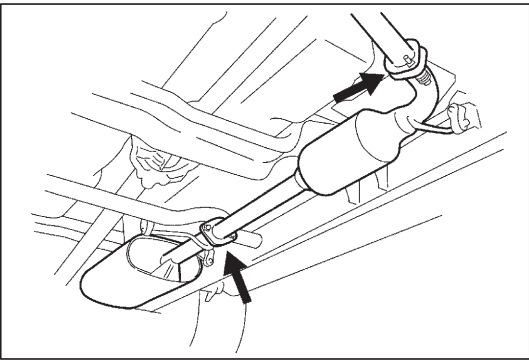
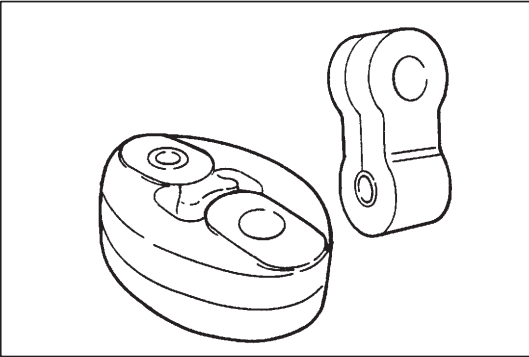

At every interval of periodic maintenance service, and when vehicle is raised for other service, check exhaust system as follows:

- Check rubber mountings for damage, deterioration, and out of position.

- Check exhaust system for leakage, loose connection, dent and damage.

If bolts or nuts are loosened, tighten them to specified torque.

Refer to "GENERAL DESCRIPTION" in this section for torque data.

- Check nearby body areas damaged, missing, or mispositioned part, open seam, hole connection or any other defect which could permit exhaust fumes to seep into vehicle.
- Make sure that exhaust system components have enough clearance from underbody to avoid overheating and possible damage to passenger compartment carpet.
- Any defect should be fixed at once.

ON-VEHICLE SERVICE

WARNING:

To avoid the danger of being burned, do not touch the exhaust system when the system is hot. Any service on the exhaust system should be performed when the system is cool.

EXHAUST MANIFOLD

Refer to "TURBOCHARGER" in Section 6E3 for removal and installation procedures. Before installation, check gasket and seal for deterioration or damage. Replace them as necessary.

MUFFLER**CAUTION:**

As exhaust No.2 pipe has catalytic converter in it, it should not be exposed to any impulse. Be careful not to drop it or hit it against something.

- Tighten bolts and nuts to specified torque when reassembling. Refer to GENERAL DESCRIPTION in this section for location of bolts and nuts.
- After installation, start engine and check each joint of exhaust system for leakage.

SECTION 7A2

MANUAL TRANSMISSION

CONTENTS

GENERAL DESCRIPTION	7A2- 2	MAIN SHAFT ASSEMBLY	7A2-26
COMPONENTS	7A2- 3	COUNTER SHAFT ASSEMBLY	7A2-27
DIAGNOSIS	7A2- 4	5TH AND REVERSE	
DIAGNOSIS TABLE	7A2- 4	SYNCHRONIZER RING	7A2-28
ON-VEHICLE SERVICE	7A2- 5	INPUT SHAFT BEARING RETAINER	
GEAR OIL INSPECTION AND		AND OIL SEAL	7A2-28
CHANGE	7A2- 5	TRANSMISSION REAR CASE	7A2-28
SHIFT CONTROL LEVERS	7A2- 6	COMPONENTS INSPECTION	7A2-29
SWITCHES	7A2- 8	INPUT SHAFT ASSEMBLY	7A2-29
TRANSFER 4WD SWITCH REMOVAL		MAIN SHAFT ASSEMBLY	7A2-30
AND INSTALLATION	7A2- 8	COUNTER SHAFT AND REVERSE	
BACK UP LIGHT SWITCH REMOVAL		IDLE GEAR	7A2-32
AND INSTALLATION	7A2- 8	UNIT ASSEMBLY	7A2-34
4WD SWITCH AND BACK UP LIGHT		GEAR SHIFT LEVER CASE	
SWITCH INSPECTION	7A2- 9	ASSEMBLY	7A2-34
ENGINE REAR MOUNTING	7A2-10	INPUT SHAFT ASSEMBLY	7A2-35
DISMOUNTING OF TRANSMISSION		MAIN SHAFT ASSEMBLY	7A2-36
UNIT	7A2-10	COUNTER SHAFT ASSEMBLY	7A2-40
REMOUNTING OF TRANSMISSION		INPUT SHAFT BEARING RETAINER	
UNIT	7A2-13	AND OIL SEAL	7A2-41
UNIT REPAIR	7A2-14	TRANSMISSION REAR CASE	7A2-41
TRANSMISSION CASE		TRANSMISSION INTERMEDIATE	
COMPONENTS	7A2-14	CASE AND FRONT CASE	
INPUT AND COUNTER SHAFT		(CLOCATION OF KNOCK AND	
COMPONENTS	7A2-15	PLUG)	7A2-42
GEAR SHIFTER COMPONENTS	7A2-16	TRANSMISSION UNIT	7A2-43
UNIT DISASSEMBLY	7A2-17	TIGHTENING TORQUE	
GEAR SHIFT LEVER CASE		SPECIFICATION	7A2-57
ASSEMBLY	7A2-17	REQUIRED SERVICE MATERIAL	7A2-57
TRANSMISSION UNIT	7A2-17	SPECIAL TOOL	7A2-58
INPUT SHAFT ASSEMBLY	7A2-26		

GENERAL DESCRIPTION

The manual transmission consists of the input shaft, main shaft, countershaft and reverse idler shaft which are installed in the die-cast aluminum alloy and cast-iron cases. This transmission provides five forward speeds and one reverse speed.

The 1st, 2nd and 3rd speeds are for speed reduction drive, 4th speed is for direct drive and 5th speed is for over drive.

The low speed (1st and 2nd) synchronizer is mounted on middle of the main shaft and engaged with the main shaft 1st or 2nd gear. The high speed (3rd and 4th) synchronizer is mounted on forefront of the main shaft and engaged with the main shaft 3rd gear or input shaft. The 5th speed synchronizer is mounted on the counter shaft and engaged with the countershaft 5th gear. The 5th speed synchronizer is also equipped with the prevention device from gear cracking noise when shifting gear into the reverse gear. The double cone synchronizer mechanism is provided to the 2nd and 3rd gear synchromesh devices for high performance of shifting into the 2nd and 3rd gear.

The gear shift lever case is located at the upper behind the transmission case and has a cam which prevents direct gear shifting from the 5th speed gear into the reverse gear.

As the die-cast aluminum alloy and cast-iron cases are sealed with liquid type gasket, it is necessary to use genuine sealant or its equivalent on its mating surface when reassembling them. Also, the case fastening bolts must be tightened to specified torque by means of the torque wrench and tightening over or below the specified torque should be avoided.

The description under "ON-VEHICLE SERVICE" in this section covers the transfer partially which is next to the transmission as well, but their gear boxes are independent and each of them has its own drain and level/filler plugs for the oil change or the level check.

For the repair procedure of the transfer unit, refer to Section 7D.

COMPONENTS

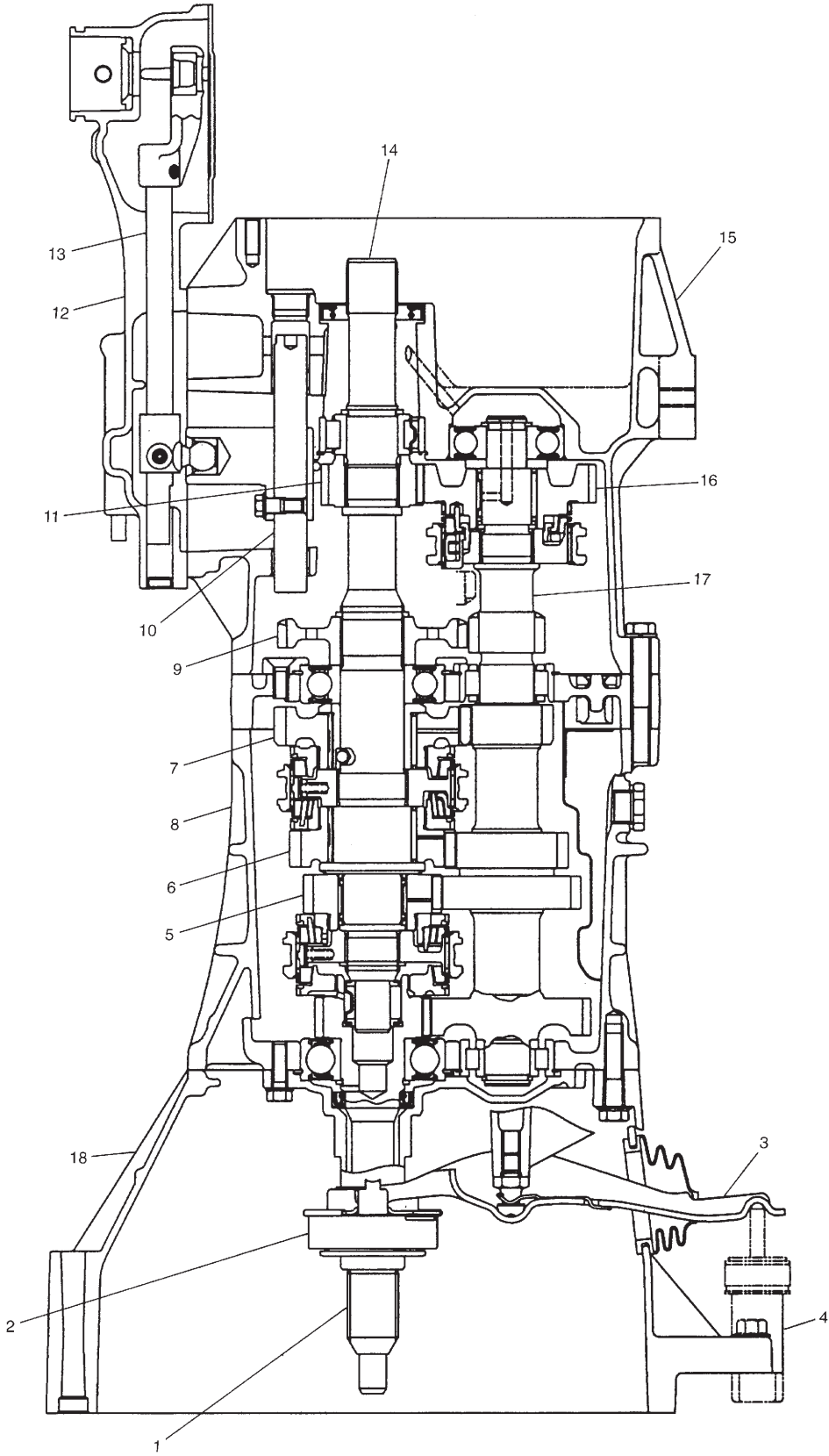

- 1. Input shaft
- 2. Clutch release bearing
- 3. Clutch release fork
- 4. Clutch operating cylinder
- 5. Main shaft 3rd gear
- 6. Main shaft 2nd gear
- 7. Main shaft low gear
- 8. Front case
- 9. Main shaft reverse gear
- 10. Gear shift inner shaft
- 11. Main shaft 5th gear
- 12. Gear shift lever case
- 13. Gear shift shaft
- 14. Main shaft
- 15. Rear case
- 16. Counter shaft 5th gear
- 17. Counter shaft
- 18. Clutch housing

DIAGNOSIS

DIAGNOSIS TABLE

Condition	Possible Cause	Correction
Gear slipping out of mesh	Worn shift fork shaft	Replace.
	Worn shift fork or synchronizer sleeve	Replace.
	Weak or damaged locating spring	Replace.
	Worn bearings on input shaft or main shaft	Replace.
	Worn chamfered tooth on sleeve or gear	Replace sleeve and gear.
	Missing or disengagement of circlip(s)	Install.
Gears refusing to disengage	Weakened or broken synchronizer spring	Replace.
	Distorted shift shaft or shift fork	Replace.
Hard shifting	Improper clutch pedal free travel	Adjust.
	Distorted or broken clutch disc	Replace.
	Damaged clutch pressure plate	Replace clutch cover.
	Worn synchronizer ring	Replace.
	Worn chamfered tooth on sleeve or gear	Replace sleeve and gear.
	Distorted shift shaft	Replace.
Noise	Inadequate or insufficient lubricant	Replenish.
	Damaged or worn bearing(s)	Replace.
	Damaged or worn gear(s)	Replace.
	Damaged or worn synchronizer ring	Replace.
	Damaged or worn chamfered tooth on sleeve or gear	Replace.

ON-VEHICLE SERVICE

GEAR OIL INSPECTION AND CHANGE

- 1) Before changing or inspecting oil, be sure to stop engine and lift vehicle horizontally.
- 2) With vehicle lifted up, check oil level and leakage. If leakage exists, correct or repair it.

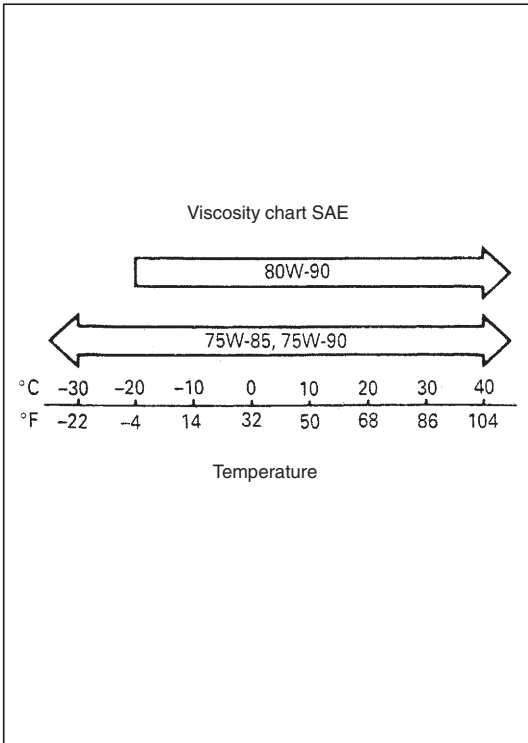

- 3) Drain old oil and fill new specified oil as shown below by specified amount (roughly up to level hole).

Gear Oil Specification

Oil grade: API GL-4

Viscosity: SAE 75W-85, 75W-90 or 80W-90

Oil Capacity:

Transmission: 2.7 liters (5.5/4.6 US/Imp. pt)

Transfer: 1.7 liters (3.6/3.0 US/Imp. pt)

NOTE:

- It is highly recommended to use SAE 75W-90 gear oil.
- Whenever vehicle is hoisted for any other service work than oil change, also be sure to check for oil leakage and status of breather hoses.
- If water or rust is mixed in drained oil, be sure to check breather hose and boot of transmission and transfer.

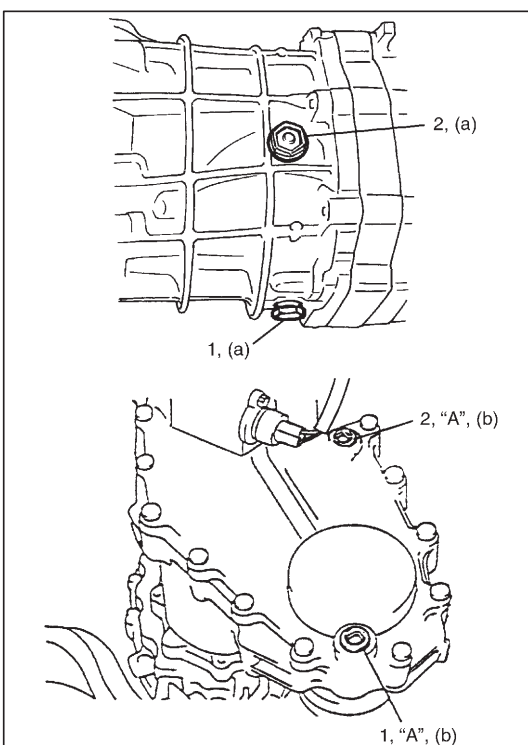

- 4) Torque drain plug (1) and level/filler plug (2) as specified below after applying sealant to thread of plug.

CAUTION:

Transmission oil must not be poured through gear shift control lever part.

"A": Sealant 99000-31110

Tightening torque

Oil drain plug and level/filer plug (on transmission case)

(a): 38 N·m (3.8 kg-m, 27.5 lb-ft)

Oil drain plug and level/filer plug (on transfer case)

(b): 23 N·m (2.3 kg-m, 17.0 lb-ft)

SHIFT CONTROL LEVERS

REMOVAL

- 1) Remove 4 screws at the front and rear and 2 clips at the center then take off front and rear center console boxes.

NOTE:

To remove clip, push in its center pin first.

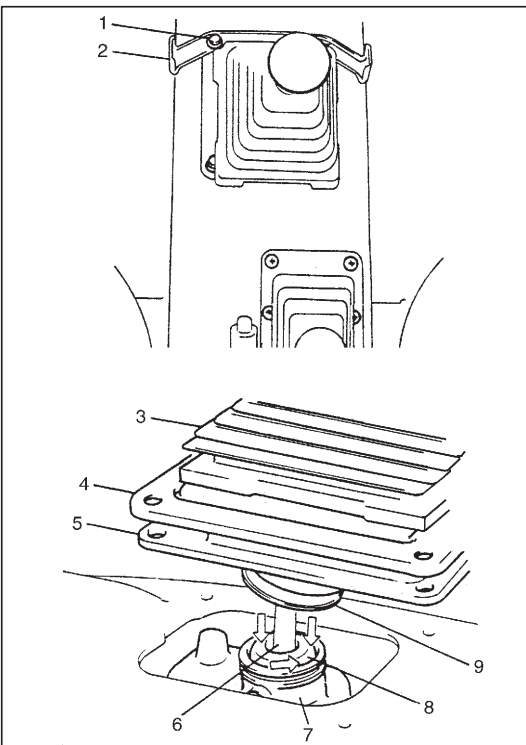
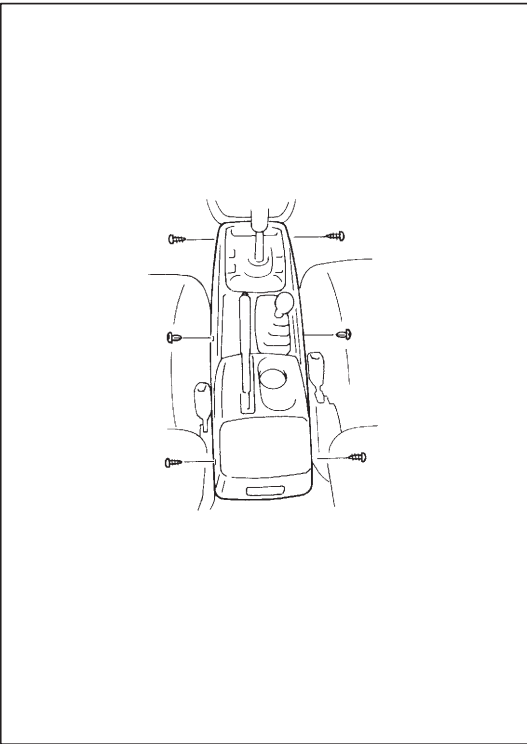

- 2) Remove console box bracket (2) by removing bolts (1).
- 3) Lift up boot No.3 (3), boot cover (4) and boot No.2 (5).
- 4) Remove boot clamp and then remove boot No.1 (9) from transmission shift lever case (7).
- 5) With gear shift control case cover (8) pushed down with fingers, turn it to counter clockwise and take out shift control lever (6).
- 6) Take out transfer shift control lever in similar manner as described above.

INSPECTION AND INSTALLATION

- 1) Check shift control lever lower portion and control lever locating sheet for excessive wear, and boot for damage. Correct or replace if necessary.
- 2) Perform above steps also for transfer shift control lever.

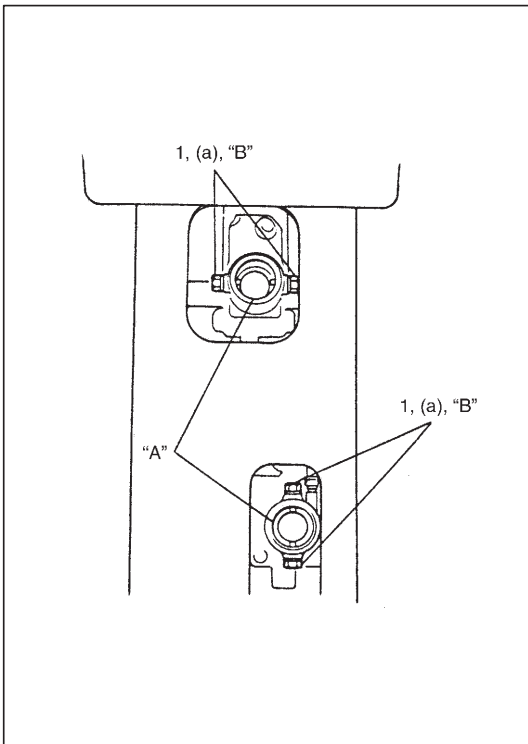

- 3) If control lever locating bolts (1) are replaced or retightened, torque them as specified below.
Replacing of control lever locating bolts (1) requires thread lock cement.

“B”: Cement 99000-32110

Tightening torque

Control lever locating bolt (a):
17 N·m (1.7 kg·m, 12.5 lb·ft)

- 4) Apply grease to pivot portions and seat, then install shift control lever.

“A”: Grease 99000-25010

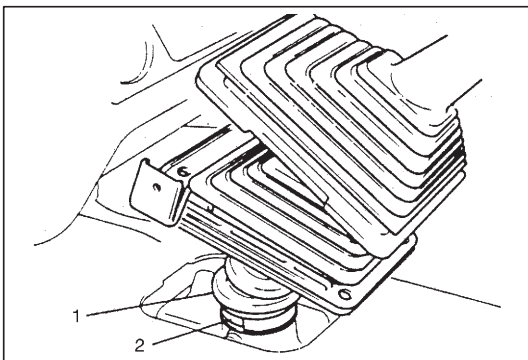

- 5) Install transmission boot No.1 (1) from inside of cabin and clamp it with a new clamp (2) securely.

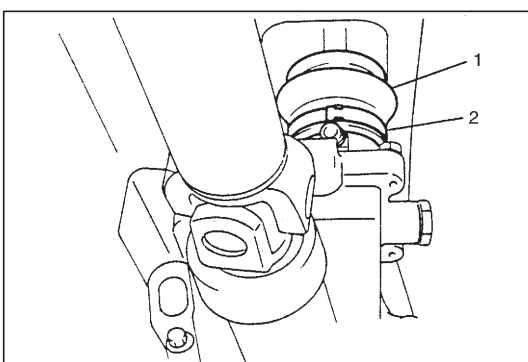

- 6) Install transfer boot No.1 (1) securely on lift and clamp it by using a new clamp (2).

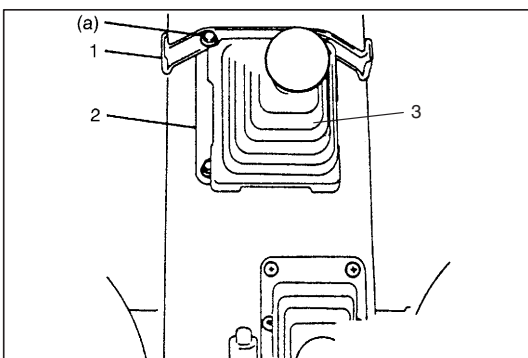

- 7) Tighten transmission boot No.2 (2) with boot cover and console box bracket (1).

Tightening torque

Control lever boot cover bolt (a):
15 N·m (1.5 kg·m, 11.0 lb·ft)

- 8) Install console box.

NOTE:

Be sure that flare end of transmission boot No.3 (3) is engaged with console box.

SWITCHES

TRANSFER 4WD SWITCH REMOVAL AND INSTALLATION

- 1) Remove console box and lift transmission control lever boots No.2 and No.3. (Refer to "SHIFT CONTROL LEVERS" in this section.)

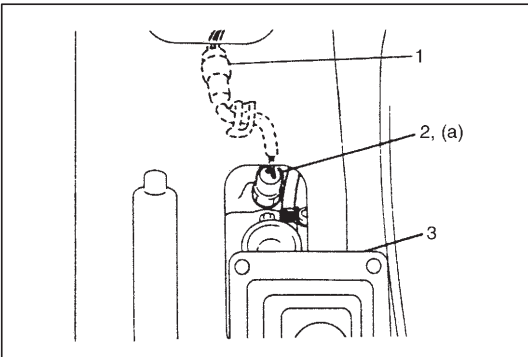

- 2) Remove transfer control lever boot No.2 (3), unclamp wiring on transfer case to free it and pull off coupler (1).
- 3) Replace 4WD switch (2) and connect as it was.

Tightening torque

4WD switch (a): 20 N·m (2.0 kg·m, 14.5 lb-ft)

- 4) Turn ON ignition switch, shift transfer shift control lever to 4WD position and check that indicator lights. Turn OFF switch after checking.

NOTE:

- When removing and reinstalling switch, use care not to let dust enter transfer box inside.
- Make sure to reset clamp for wiring which is located where invisible directly.
- It is recommended to work on transfer shift control lever boot No.1 from underside of vehicle on lift.
- Identify this 4WD switch (2) by its leg part which is different for that of back up light switch (1).

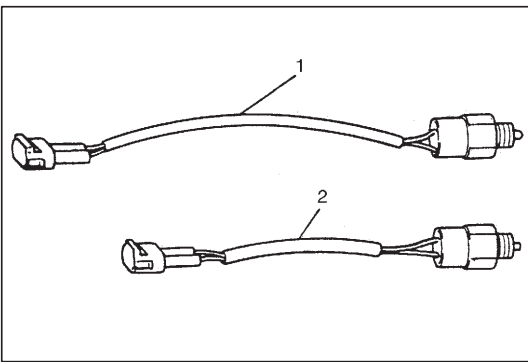

BACK UP LIGHT SWITCH REMOVAL AND INSTALLATION

WARNING:

Refrain from work while exhaust center pipe is hot.

NOTE:

When replacing switch, use care not to let dust enter transmission through switch hole.

- 1) Lift up vehicle.
- 2) Remove coupler(s) (1) for switch wiring.

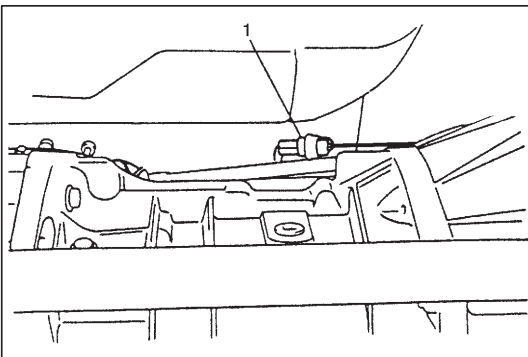

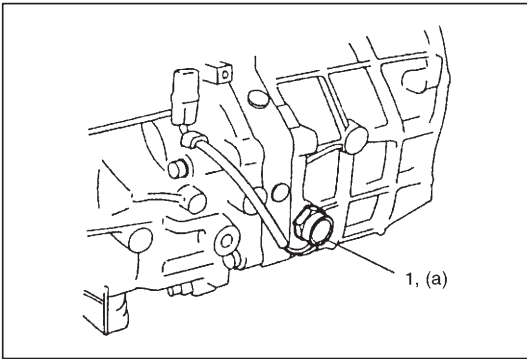

- 3) Replace back up light switch (1), connect and clamp as they were.

Tightening torque

Back up light switch (a):
45 N·m (4.5 kg-m, 32.5 lb-ft)

- 4) Check switch for proper function with ignition switch turned ON and gear shifted to reverse position. Turn OFF switch after checking its function.

4WD SWITCH AND BACK UP LIGHT SWITCH INSPECTION

- 1) Undo clamp and disconnect coupler of back up light switch and/or 4WD switch.

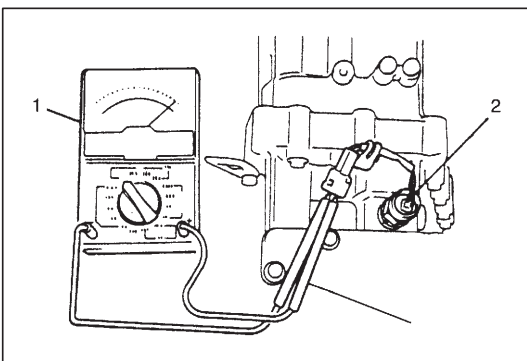

- 2) Function of back up light switch (2) can be checked by using Ohmmeter (1) as shown in the figure. There should be conduction at these terminals only when shift lever is shifted to reverse position.
- 3) Function of transfer 4WD switch (2) can be checked in the same manner as back up light switch (2). There should be conduction at these terminals when shift lever is shifted to 4H, and 4L positions.
- 4) Upon completion of check, connect coupler and clamp wiring harness as they were.

NOTE:

When replacing switch(es), use care not to let dust enter transmission through switch hole(s).

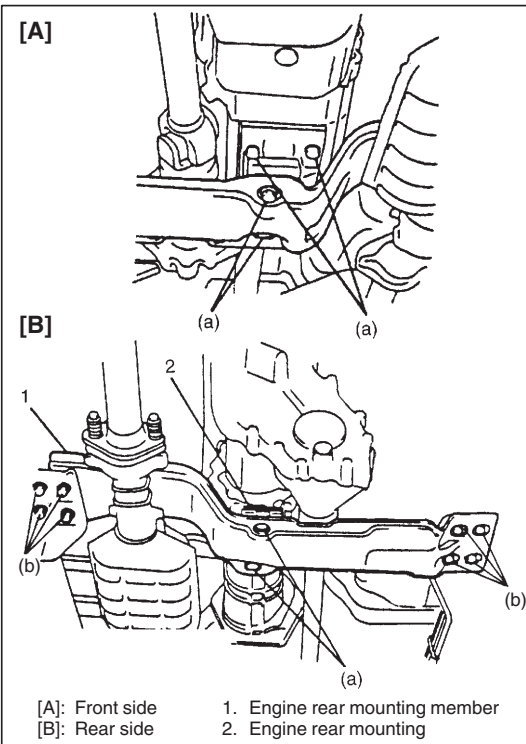

ENGINE REAR MOUNTING

When replacement of mounting parts are necessary, torque bolts as specified below.

Tightening torque

Engine rear mounting bolts (a):

50 N·m (5.0 kg-m, 36.5 lb-ft)

Engine rear mounting member bolts (b):

50 N·m (5.0 kg-m, 36.5 lb-ft)

DISMOUNTING OF TRANSMISSION UNIT

IN CABIN

Remove transmission shift control lever (Refer to "SHIFT CONTROL LEVERS" in this section.) and transfer shift control lever knob.

IN ENGINE ROOM

1) Remove battery.

2) Untie breather hose which is tied to engine harness by losing clamp.

3) Disconnect CKP sensor connector from CKP sensor (2).

4) Remove CKP sensor mounting bolt (3) and then remove CKP sensor (2) from clutch housing.

5) Remove transmission fastening bolt (1).

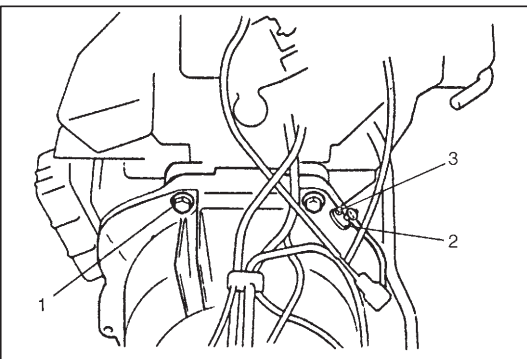

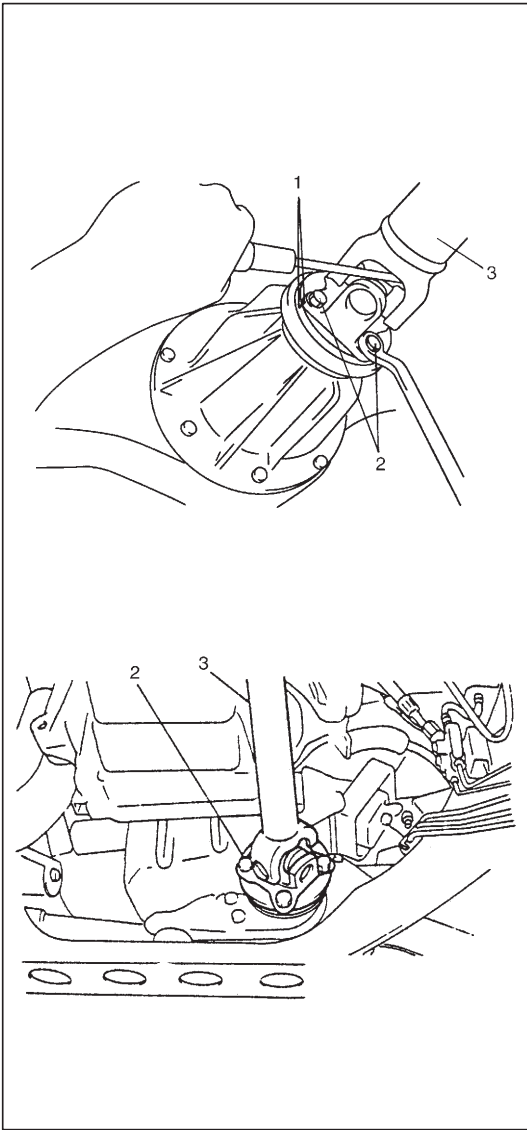
**ON LIFT**

- 1) Drain oil from transmission and transfer.
- 2) Remove starting motor.
- 3) Give match marks (1) on joint flange and propeller shaft (3) as shown in figure. (front and rear)
- 4) Remove flange bolts (2) of rear propeller shaft universal joint and pull out propeller shaft (3).
- 5) Remove flange bolts (2) and nuts of front propeller shaft universal joint and pull out propeller shaft (3).
- 6) Remove clutch operating cylinder from transmission. It is not necessary to disconnect clutch hose from operating cylinder.

NOTE:

- It is not necessary to drain transmission oil when dismounting transmission and transfer for clutch maintenance only.
- Work without draining transfer oil is possible if front propeller shaft is dismantled together with transmission and transfer.

- 7) Remove exhaust No.1 and No.2 pipe.
- 8) Remove stabilizer bar mount bush bracket bolts.

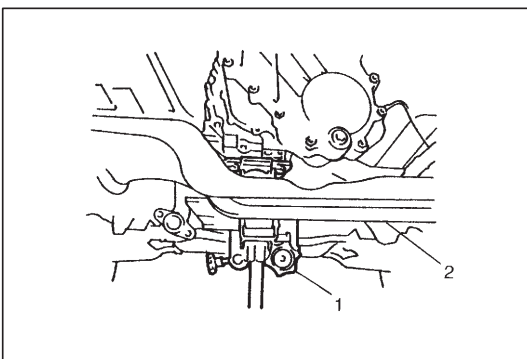

- 9) Apply transmission jack (1) and remove engine rear mounting member (2) taking off its bolts.
- 10) Remove rear mounting by removing its bolts.

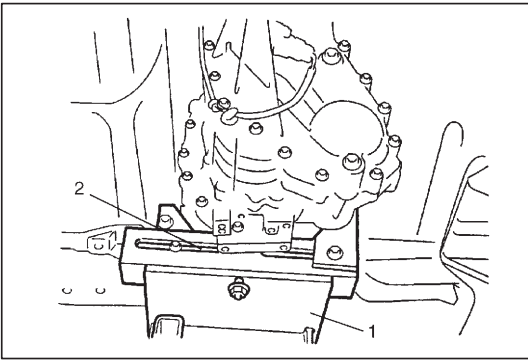

- 11) Lower transmission jack slowly, remove it from transmission and install auxiliary arm (2) to transmission jack (1).
- 12) Raise transmission jack until it touches transmission.
- 13) Disconnect couplers from 4WD switch, back up light switch and speed sensor assembly and release their harness from clamps.
- 14) Remove engine to transmission bolts and nuts.
- 15) With transmission assembly held up on jack, move them to rear and lower them.

WARNING:

Transmission assembly may tilt rearward on jack. It is recommended to use an auxiliary arm of jack for purpose of safety.

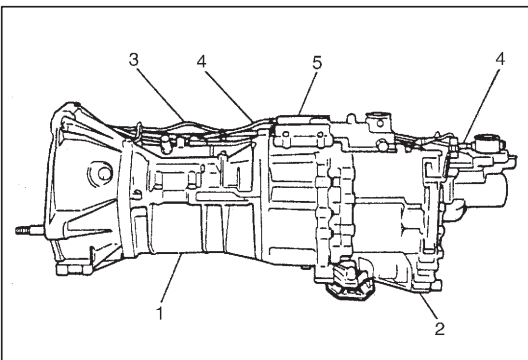

- 16) Remove wiring harness (3), harness clamp bolt and breather hoses (4).
- 17) Separate gear shift lever case (5) and transfer assembly (2) from transmission assembly (1).

REMountING OF TRANSMISSION UNIT

Reverse dismounting procedure for remounting, and then note the following instruction.

- Slant the rear of the engine down, using support device (1) and install transmission to engine.
- Use specified torques as given below.

Tightening torque

Transmission to engine bolts and nuts (a):

55 N·m (5.5 kg-m, 40.0 lb-ft)

Engine rear mounting member bolts (b):

50 N·m (5.0 kg-m, 36.5 lb-ft)

Exhaust No.1 pipe to manifold nuts (c):

60 N·m (6.0 kg-m, 43.5 lb-ft)

Exhaust No.1 pipe to exhaust No.2 pipe bolts:

50 N·m (5.0 kg-m, 36.5 lb-ft)

Exhaust No.2 pipe to muffler nuts (d):

60 N·m (6.0 kg-m, 43.5 lb-ft)

Front propeller shaft universal joint flange bolts (e):

50 N·m (5.0 kg-m, 36.5 lb-ft)

Rear propeller shaft universal joint flange bolts (f):

60 N·m (6.0 kg-m, 43.5 lb-ft)

Engine rear mounting bolts (g):

50 N·m (5.0 kg-m, 36.5 lb-ft)

CKP sensor mounting bolt:

10 N·m (1.0 kg-m, 7.5 lb-ft)

Stabilizer bar mount bush bracket bolts:

23 N·m (2.3 kg-m, 17.0 lb-ft)

- Set each clamp for wiring, hoses and cable securely.
- Set clamp for shift control lever boots securely.
- After installing clutch operating cylinder, check clutch pedal free travel. Refer to Section 7C1.
- Fill gear oil to transmission and transfer as specified.
- Connect battery and check function of engine, clutch, transmission and transfer.
- When installing propeller shaft, align the match marks (2).

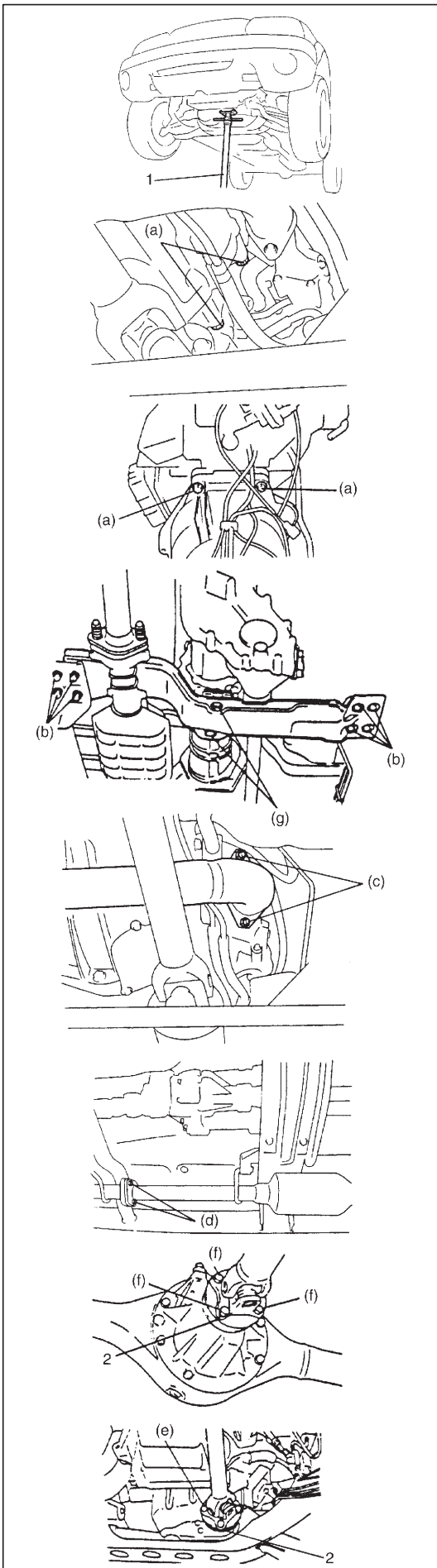





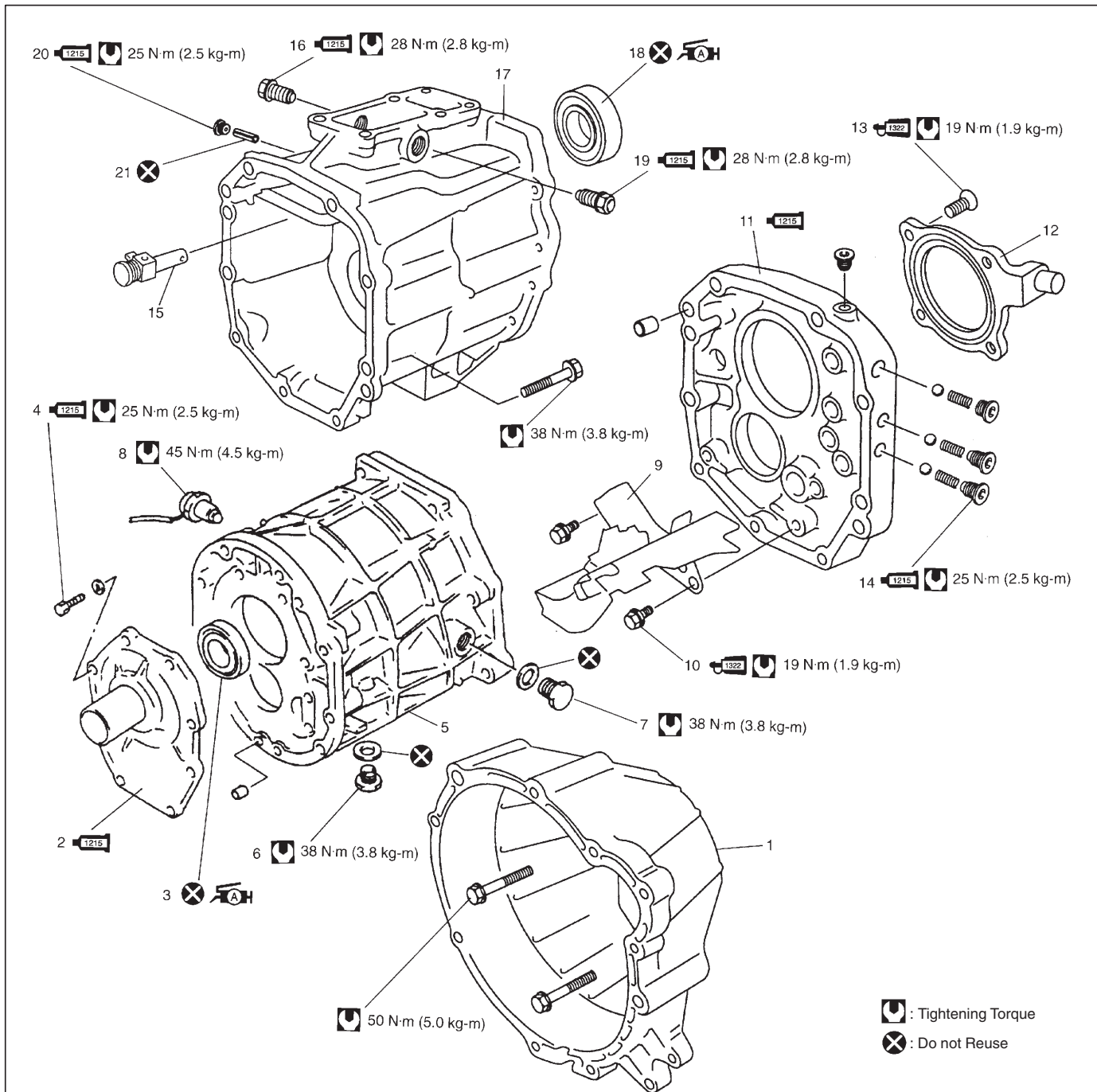











UNIT REPAIR

TRANSMISSION CASE COMPONENTS



 : Tightening Torque

 : Do not Reuse

- | | | |
|--|--|--|
|  1. Clutch housing |  10. Oil plate bolt
: Apply thread lock 99000-32110 to all around thread part of bolt. |  15. 5th-reverse interlock cam comp. |
|  2. Input shaft bearing retainer
: Apply sealant 99000-31110 to mating surface to transmission front case. |  11. Transmission intermediate case
: Apply sealant 99000-31110 to mating surface to transmission front and rear case. |  16. Return spring low bolt
: Apply sealant 99000-31110 to all around thread part of bolt. |
|  3. Oil seal
: Apply grease 99000-25010 to oil seal lip. |  12. Main and counter shaft bearing retainer |  17. Transmission rear case |
|  4. Input shaft bearing retainer bolt
: Apply sealant 99000-31110 to all around thread part of bolt. |  13. Main and counter shaft bearing retainer screw
: Apply thread lock 99000-32110 to all around thread part of screw. |  18. Main shaft oil seal
: Apply grease 99000-25010 to oil seal lip. |
| 5. Transmission front case |  14. Locating spring screw
: Apply sealant 99000-31110 to all around thread part of screw. |  19. Return spring reverse bolt
: Apply sealant 99000-31110 to all around thread part of bolt. |
| 6. Oil drain plug | |  20. Interlock cam plug
: Apply sealant 99000-31110 to all around thread part of plug. |
| 7. Oil filler/level plug | | 21. Interlock cam pin |
| 8. Back-up light switch | | |
| 9. Oil plate | | |

INPUT AND COUNTER SHAFT COMPONENTS

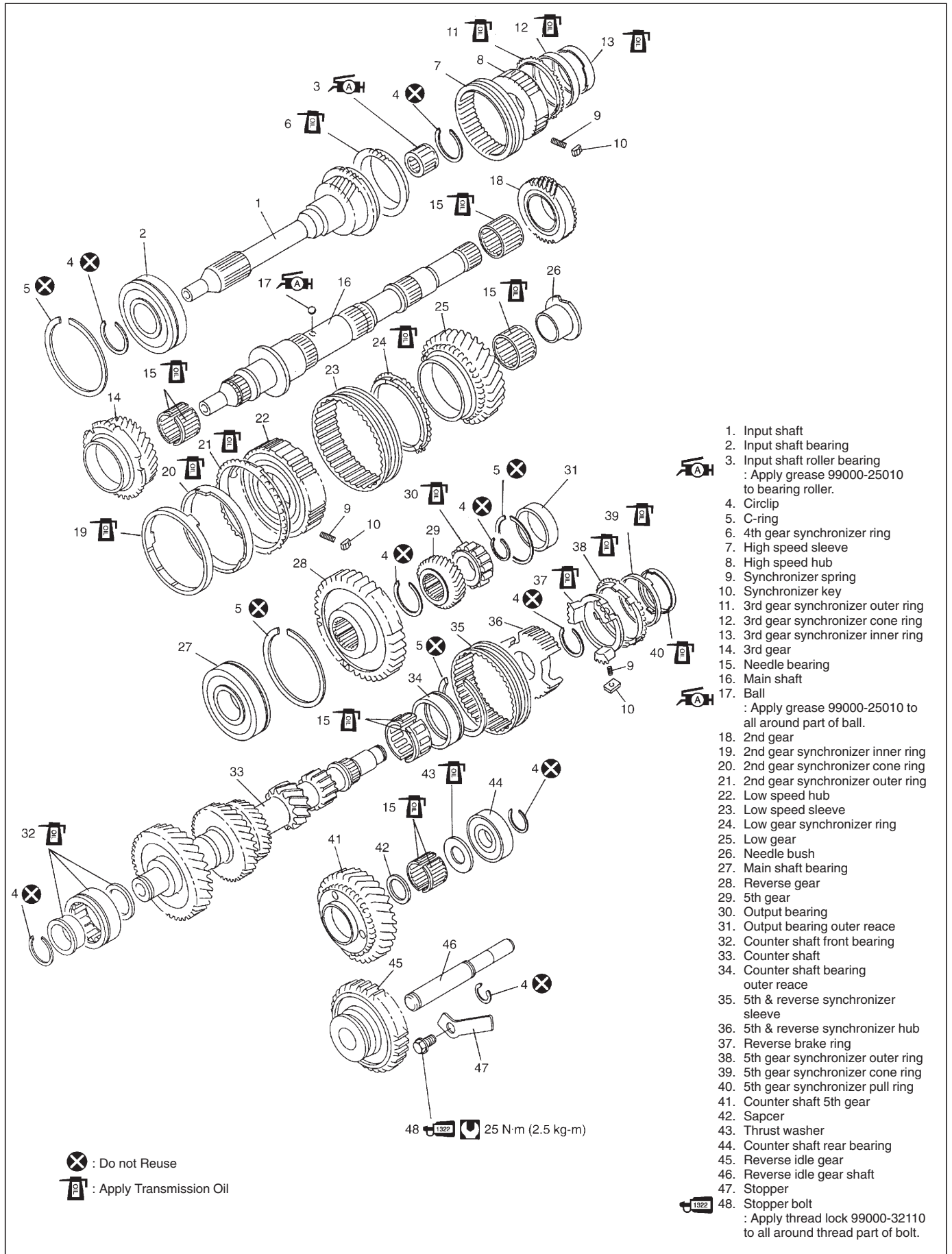

1. Input shaft
2. Input shaft bearing
3. Input shaft roller bearing : Apply grease 99000-25010 to bearing roller.
4. Circlip
5. C-ring
6. 4th gear synchronizer ring
7. High speed sleeve
8. High speed hub
9. Synchronizer spring
10. Synchronizer key
11. 3rd gear synchronizer outer ring
12. 3rd gear synchronizer cone ring
13. 3rd gear synchronizer inner ring
14. 3rd gear
15. Needle bearing
16. Main shaft
17. Ball : Apply grease 99000-25010 to all around part of ball.
18. 2nd gear
19. 2nd gear synchronizer inner ring
20. 2nd gear synchronizer cone ring
21. 2nd gear synchronizer outer ring
22. Low speed hub
23. Low speed sleeve
24. Low gear synchronizer ring
25. Low gear
26. Needle bush
27. Main shaft bearing
28. Reverse gear
29. 5th gear
30. Output bearing
31. Output bearing outer race
32. Counter shaft front bearing
33. Counter shaft
34. Counter shaft bearing outer race
35. 5th & reverse synchronizer sleeve
36. 5th & reverse synchronizer hub
37. Reverse brake ring
38. 5th gear synchronizer outer ring
39. 5th gear synchronizer cone ring
40. 5th gear synchronizer pull ring
41. Counter shaft 5th gear
42. Sapcer
43. Thrust washer
44. Counter shaft rear bearing
45. Reverse idle gear
46. Reverse idle gear shaft
47. Stopper
48. Stopper bolt : Apply thread lock 99000-32110 to all around thread part of bolt.

⊗ : Do not Reuse
 ☒ : Apply Transmission Oil

48 25 N·m (2.5 kg·m)

UNIT DISASSEMBLY

GEAR SHIFT LEVER CASE ASSEMBLY

1) Remove case plate.

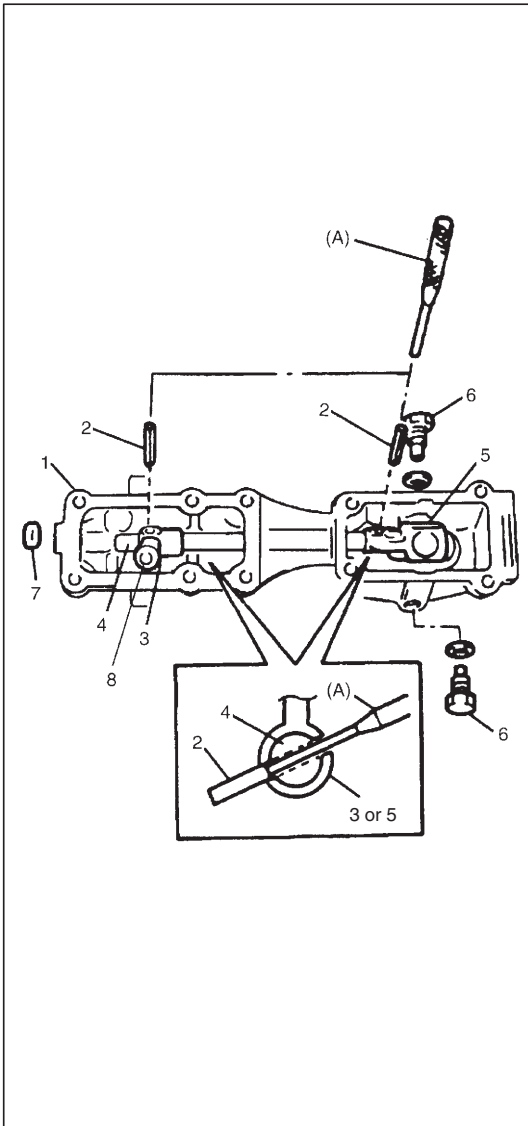

2) With case supported with soft jawed vise, remove lever locating bolts (6).

NOTE:

Use aluminum plates between vise and case to protect case against damage.

3) Using special tool, drive spring pin (2) into gear shift arm (5) as far as the position shown in the figure.

CAUTION:

When driving spring pin (2), use care not to damage gear shift lever case (1).

Special tool

(A): 09922-85811

4) Likewise, drive spring pin (2) into gear shift lever (3) as far as the position shown in the figure.

CAUTION:

When driving spring pin (2), use care not to damage gear shift lever case (1).

Special tool

(A): 09922-85811

5) Remove case plug (7).

6) Pull out gear shift shaft (4) from gear shift lever case (1) and take out gear shift lever (3).

7) Remove gear shift lever bush (8).

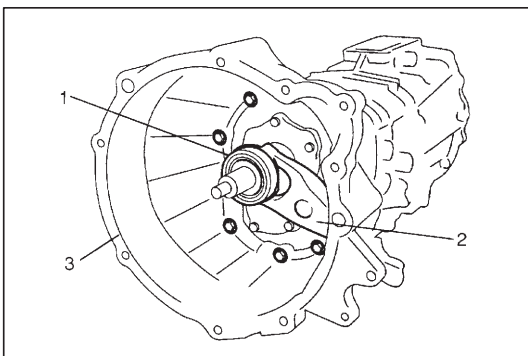

TRANSMISSION UNIT

1) Remove clutch release bearing (1), release fork (2) and clutch housing (3).

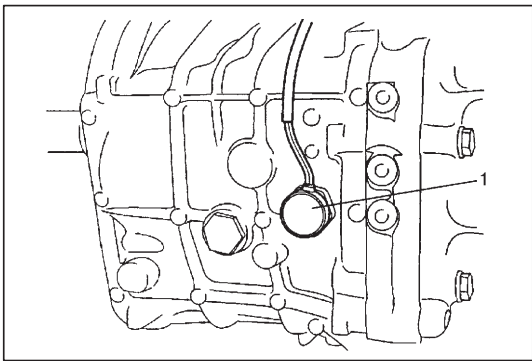

2) Remove back-up light switch (1).

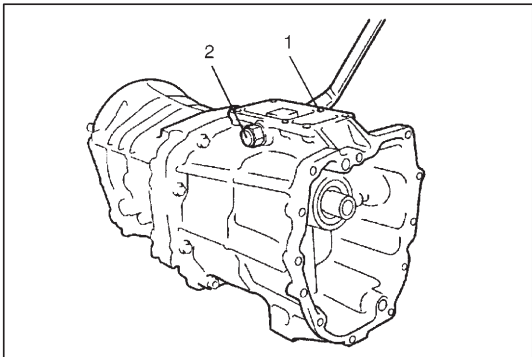

3) Remove return spring low bolt (1) and return spring reverse bolt (2).

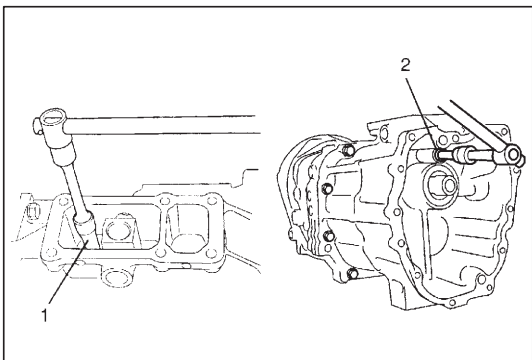

4) Remove gear shift shaft inner bolt (1) and plug (2).

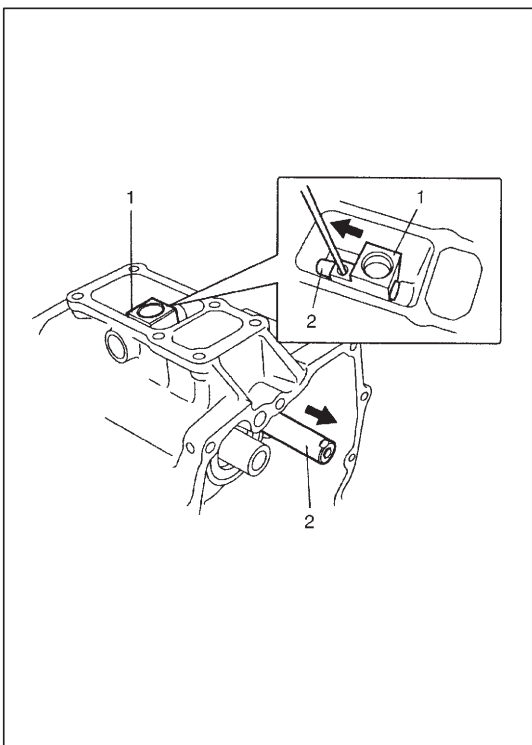

5) Using bolt hole, pull gear shift inner shaft (2) and then remove gear shift shaft inner lever (1).

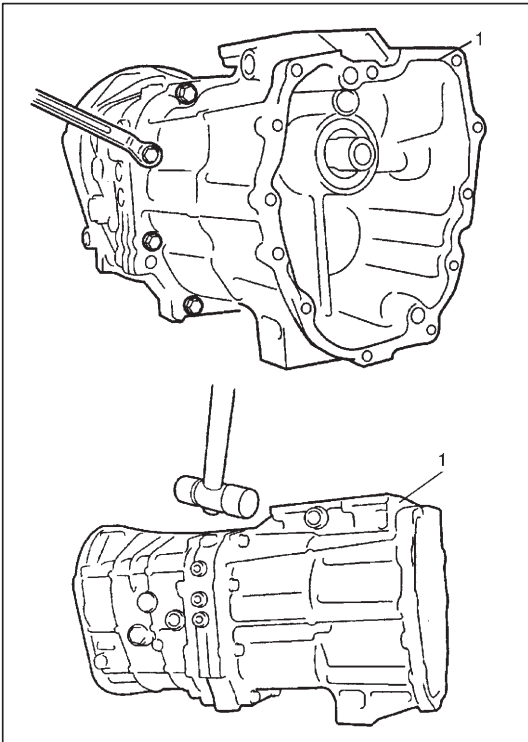

- 6) After removing transmission case bolts, tapping transmission rear case (1) flanges with plastic hammer, remove transmission rear case.

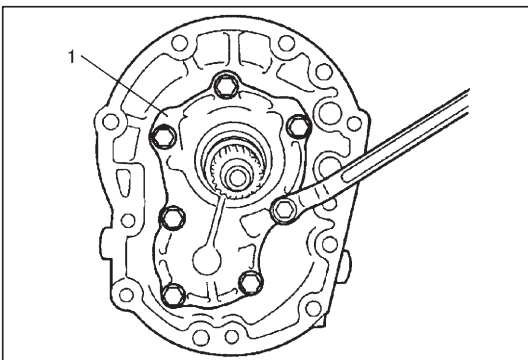

- 7) Remove input shaft bearing retainer (1).

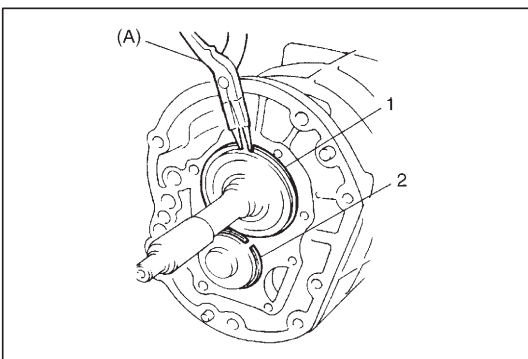

- 8) Remove C-ring (1) of input shaft bearing and C-ring (2) of counter shaft front bearing.

Special tool
(A): 09900-06107

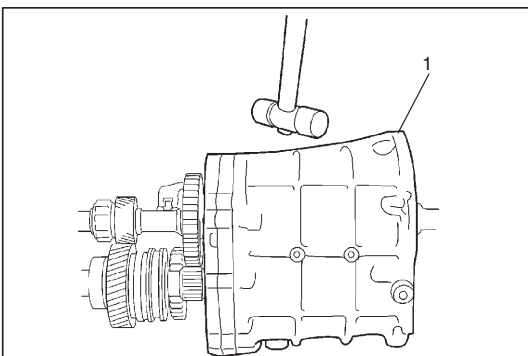

- 9) Tapping transmission front case (1) flanges with plastic hammer, remove transmission front case.
 10) Set transmission intermediate case on vise securely.

NOTE:
Use aluminum plates between vise and intermediate case to protect intermediate case against damage.

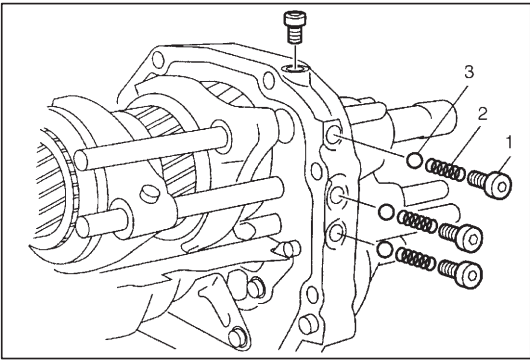

11) Remove locating screws (1), locating springs (2) and locating balls (3) as shown in the figure.

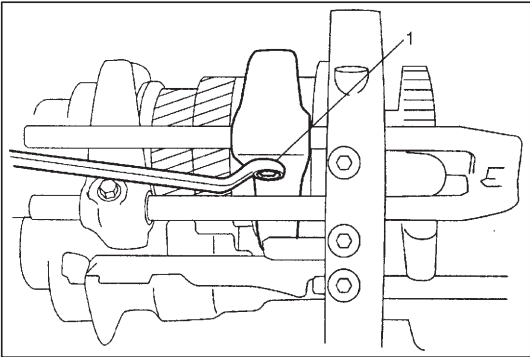

12) Remove low speed gear shift fork bolt (1).

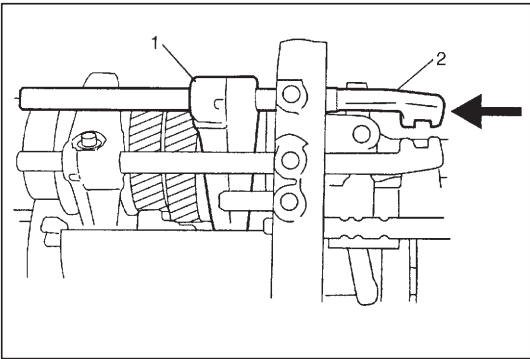

13) Remove low gear shift shaft (2) and low speed gear shift fork (1).

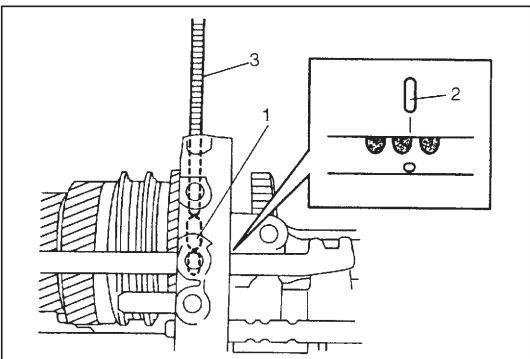

14) Remove interlock pin (1) and straight pin (2) by using magnet (3).

NOTE:

When straight pin (2) can't be removed, push 5th reverse gear shift shaft back and forth lightly, then remove strait pin with magnet (3).

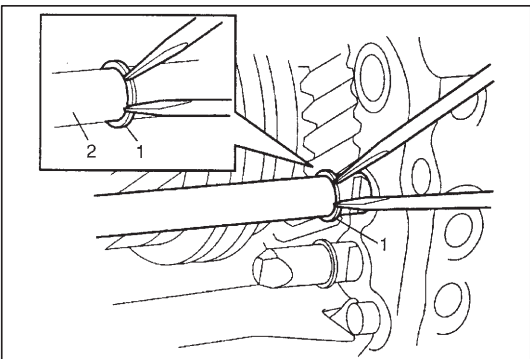

15) Remove circlip (1) from high speed gear shift shaft (2) as shown in the figure.

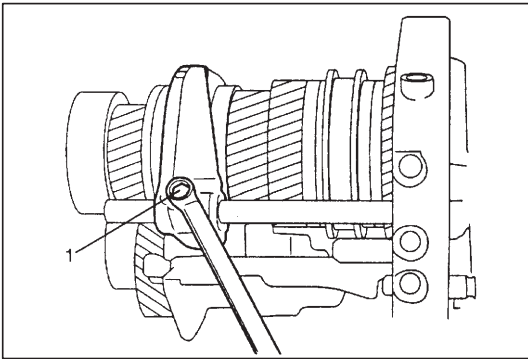

16) Remove high speed gear shift fork bolt (1).

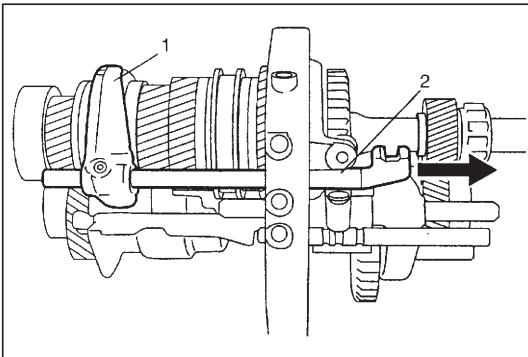

17) Remove high speed gear shift shaft (2) and high speed gear shift fork (1).

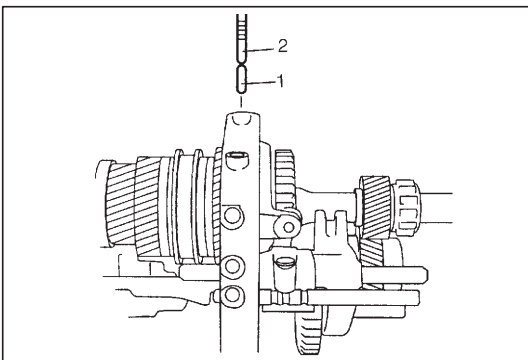

18) Remove interlock pin (1) by using magnet (2).

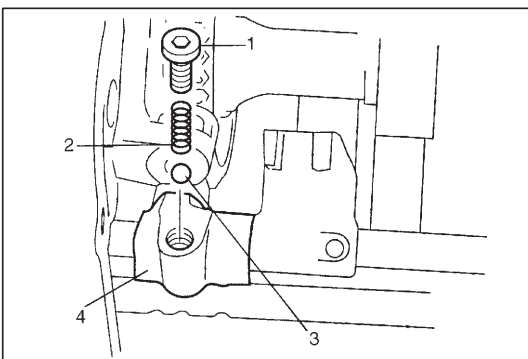

19) After removing straight plug screw (1), remove compression spring (2) and ball (3) by using magnet from reverse gear shift link comp. (4).

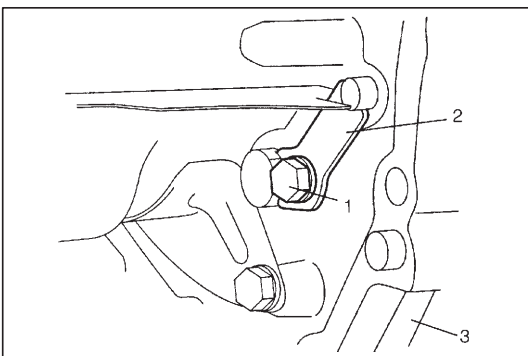

20) Remove bolt (1) and stopper (2) from intermediate case (3).

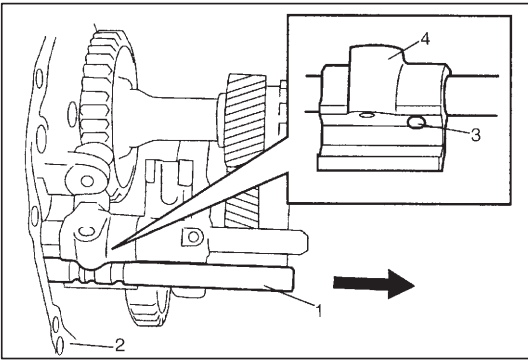

- 21) Remove 5th & reverse guide shaft (1) from intermediate case (2).

NOTE:

When pulling 5th & reverse guide shaft (1), place hand so as to catch straight pin (3) dropping from reverse gear shift link comp. (4).

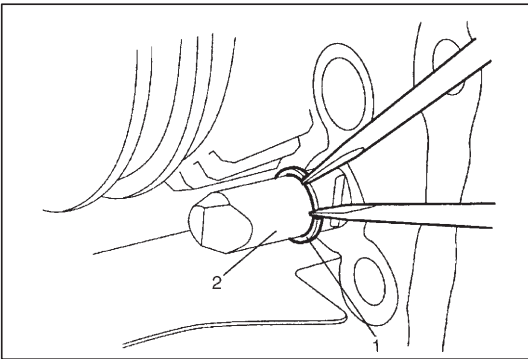

- 22) Remove circlip (1) from 5th gear shift shaft (2) as shown in the figure.

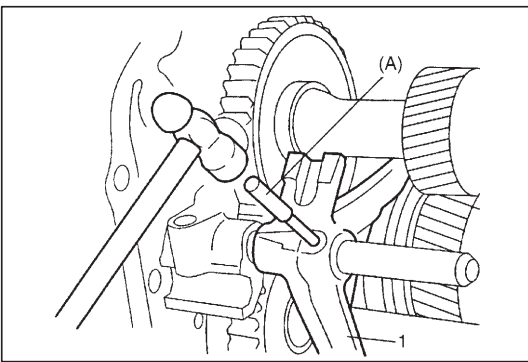

- 23) Remove spring pin from 5th gear shift fork (1).

Special tool

(A): 09922-85811

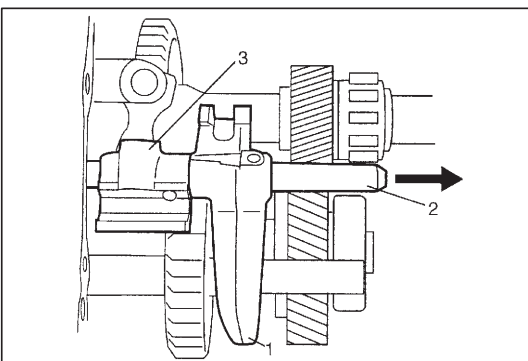

- 24) Remove 5th gear shift shaft (2), 5th gear shift fork (1) and reverse gear shift link comp. (3).

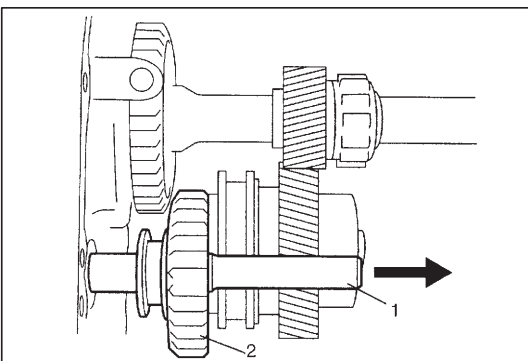

- 25) Remove reverse idler gear shaft (1) and reverse idler gear (2) from intermediate case.

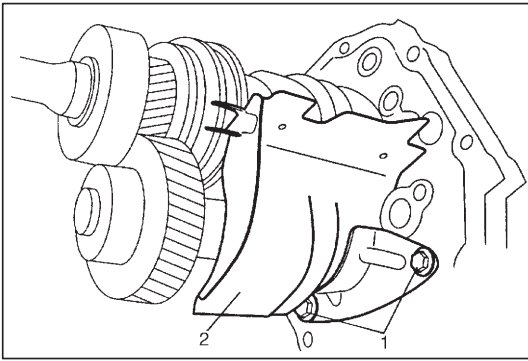

26) Remove oil plate mounting bolts (1) and then remove oil plate (2) from intermediate case.

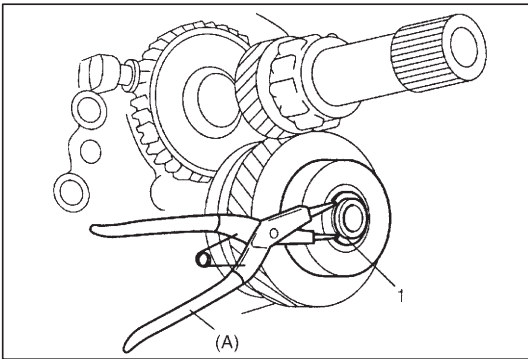

27) Remove circlip (1) from counter shaft.

Special tool
(A): 09900-06107

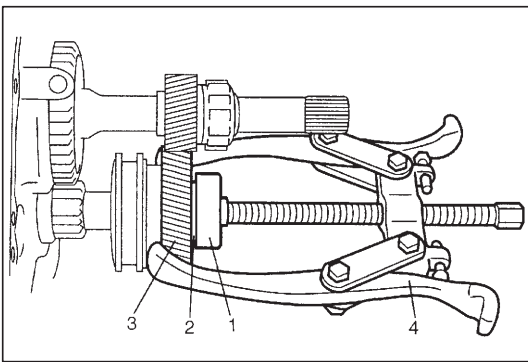

28) Remove bearing (1), spacer (2), counter shaft 5th gear (3) and counter shaft 5th gear needle bearing by using puller (4).

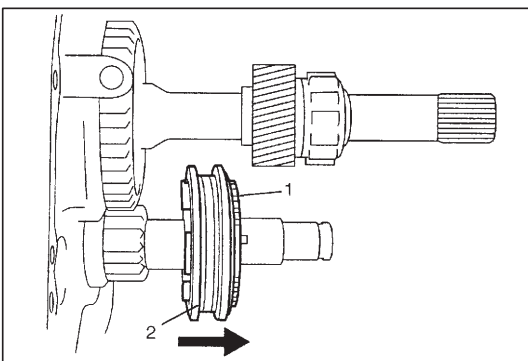

29) Pull off 5th & reverse synchronizer ring assembly (1) and 5th & reverse synchronizer sleeve (2) from counter shaft.

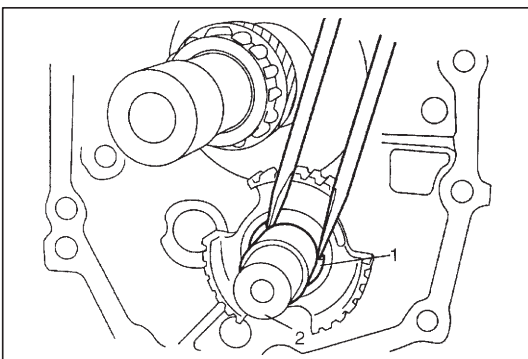

30) Remove spacer and circlip (1) from counter shaft (2) as shown in the figure.

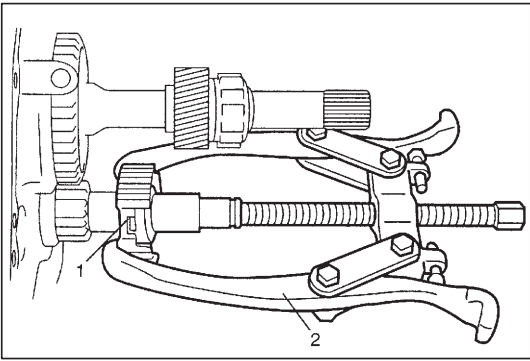

31) Remove 5th & reverse synchronizer hub (1) by using puller (2).

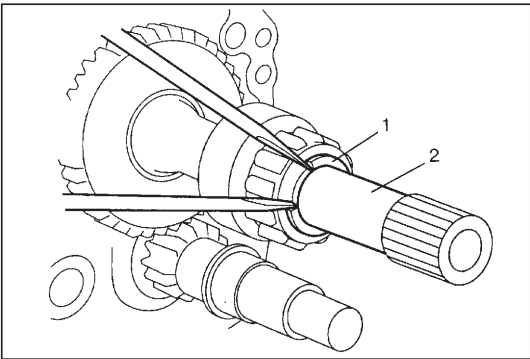

32) Remove circlip (1) from main shaft (2) as shown in the figure.

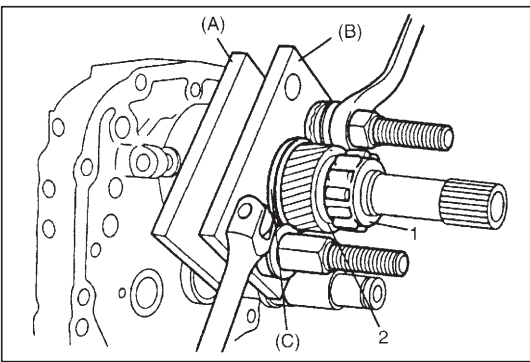

33) Remove output bearing (1) and 5th gear (2) by using special tool.

Special tool

(A): 09926-36510-001

(B): 09926-36510-002

(C): 09926-36510-003

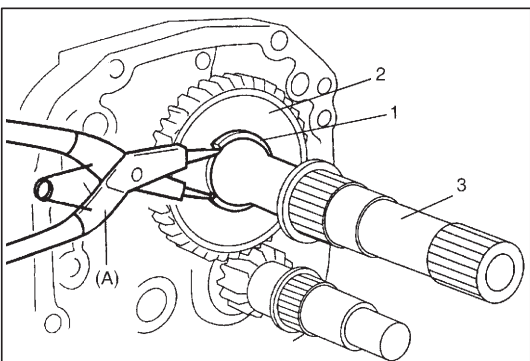

34) Remove circlip (1) and then remove reverse gear (2) from main shaft (3).

Special tool

(A): 09900-06107

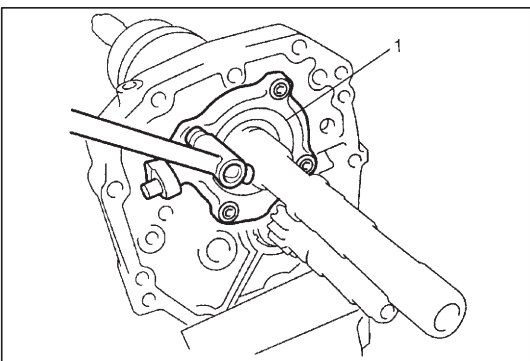

35) Remove main and counter shaft bearing retainer (1).

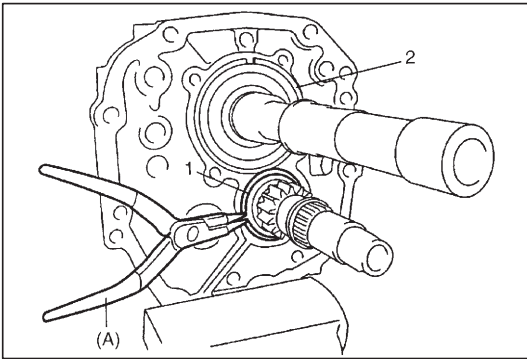

- 36) Remove C-ring (1) of counter shaft bearing and C-ring (2) of main shaft bearing.

Special tool

(A): 09900-06107

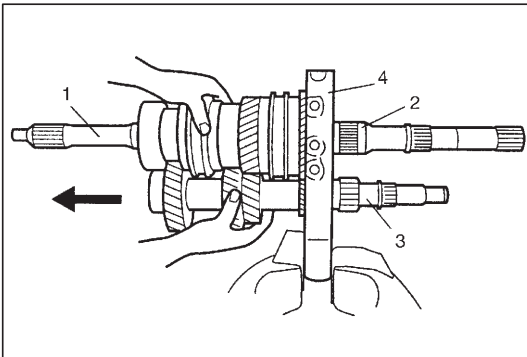

- 37) Pull off input shaft assembly (1), main shaft assembly (2) and counter shaft assembly (3) together from intermediate case (4) as shown in the figure.

NOTE:

When input shaft assembly (1), main shaft assembly (2) and counter shaft assembly (3) can't be pulled off by hand from intermediate case (4), pull off them by tapping lightly both the rear of main shaft and counter shaft alternately using a plastic hammer, taking care the counter shaft assembly (3) does not fall off.

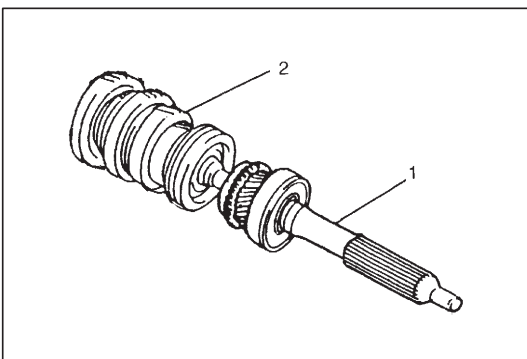

- 38) Remove input shaft assembly (1) with synchronizer ring from main shaft assembly (2).

NOTE:

When removing input shaft, be careful not to drop bearing.

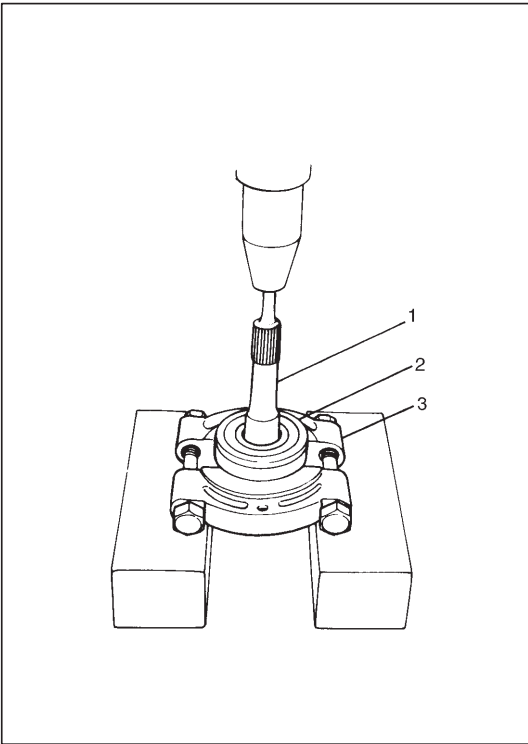

INPUT SHAFT ASSEMBLY

Remove circlip of input shaft (1) and pull out bearing (2) with puller (3) and press.

CAUTION:

Sealed bearing must not be washed.

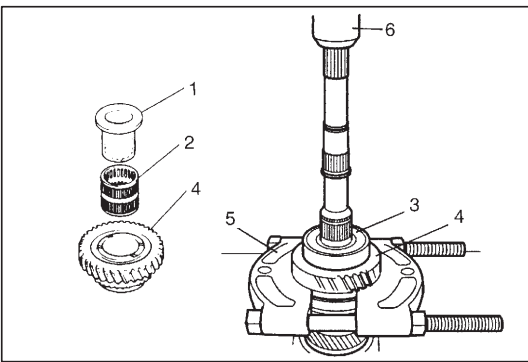

MAIN SHAFT ASSEMBLY

1) Pull out needle bush (1), needle bearing (2), main shaft bearing (3) and low gear (4) together by using puller (5) and press (6).

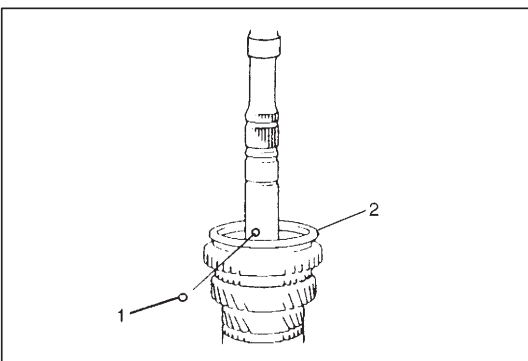

2) Remove low gear synchronizer ring (2) and ball (1).

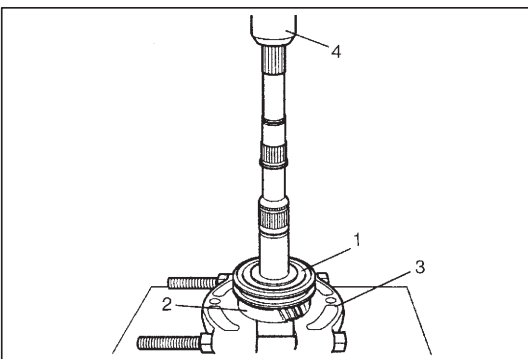

3) Pull out 2nd gear (2), needle bearing, 2nd gear synchronizer outer ring, cone ring, inner ring and low speed synchronizer sleeve/hub assembly (1) together by using puller (3) and press (4).

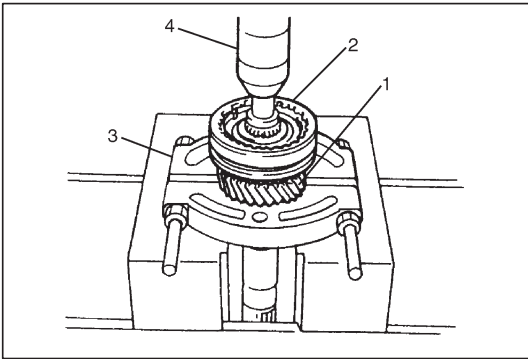

- 4) Remove circlip from front part of main shaft and pull out 3rd gear (1), needle bearing, 3rd gear synchronizer outer ring, cone ring, inner ring and high speed synchronizer sleeve/hub assembly (2) together by using puller (3) and press (4).

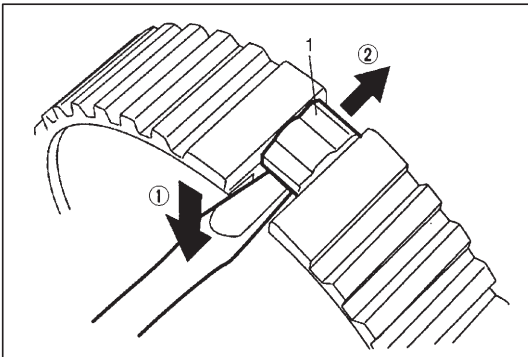

- 5) Remove high speed synchronizer sleeve from high speed synchronizer hub and then remove keys (1) and springs from high speed synchronizer hub by using slotted screwdriver or the like as shown in the figure.
- 6) Remove low speed synchronizer sleeve/hub in similar manner as discribed above.

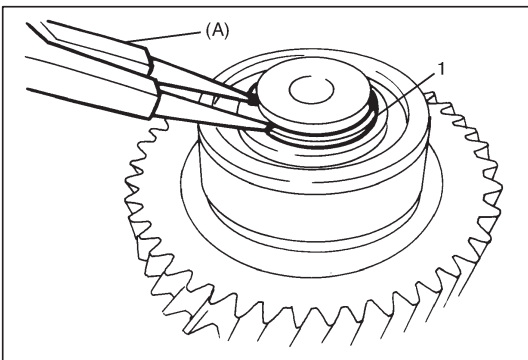

COUNTER SHAFT ASSEMBLY

- 1) Remove circlip (1) from counter shaft.

Special tool
(A): 09900-06107

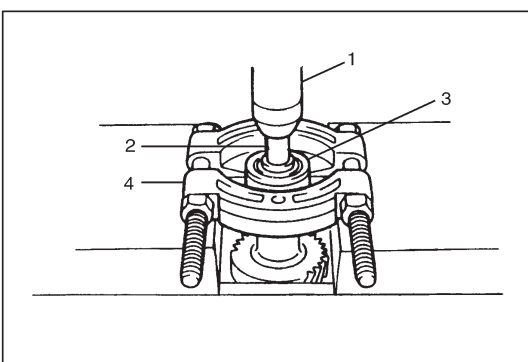

- 2) Pull out cylindrical roller bearing (3) from counter shaft by using puller (4), press (1) and rod (diameter approx. 22 mm (0.87 in.)) (2).

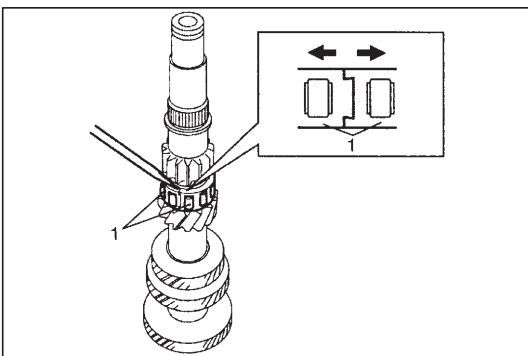

- 3) Remove counter shaft bearing (1) as shown in the figure.

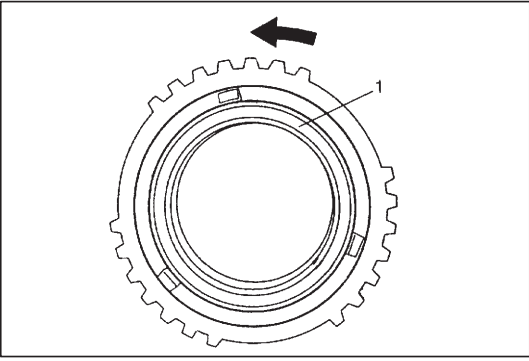

5TH AND REVERSE SYNCHRONIZER RING

1) Turn 5th gear synchronizer pull ring (1) around 45 degrees and then remove 5th gear synchronizer pull ring and 5th gear synchronizer cone ring from 5th gear synchronizer outer ring.

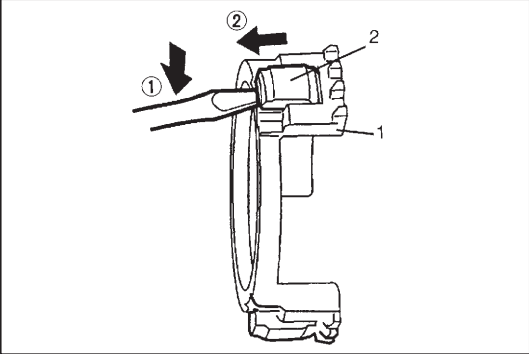

2) Remove 5th gear synchronizer outer ring from reverse brake ring (1) and then remove keys (2) and springs from reverse brake ring by using slotted screw driver or the like as shown in the figure.

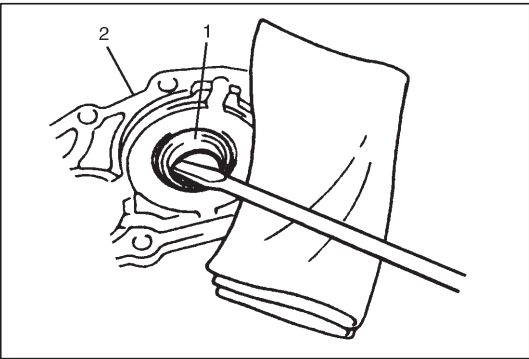

INPUT SHAFT BEARING RETAINER AND OIL SEAL

Remove oil seal (1) from bearing retainer (2) by using rod or the like as shown in the figure.

NOTE:

Unless oil seal is leaky or its lip is excessively hardened, replacement is not necessary.

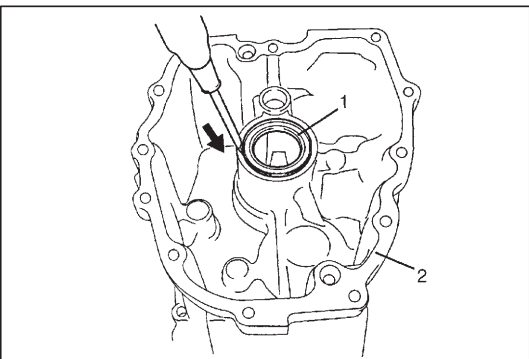

TRANSMISSION REAR CASE

1) Take out oil seal (1) from rear case (2).

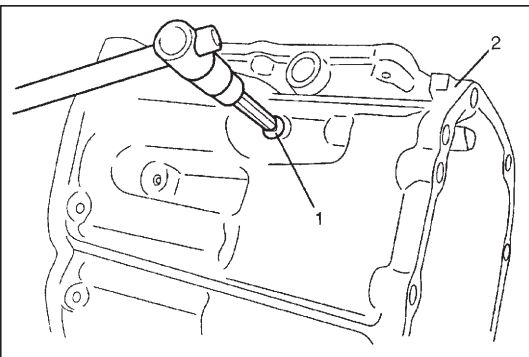

2) Remove interlock cam plug (1) from rear case (2).

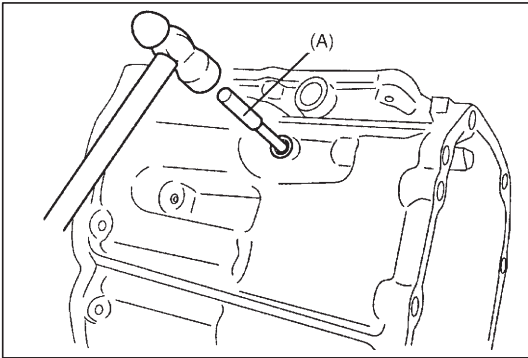

3) Remove pin by using special tool.

Special tool
(A): 09922-85811

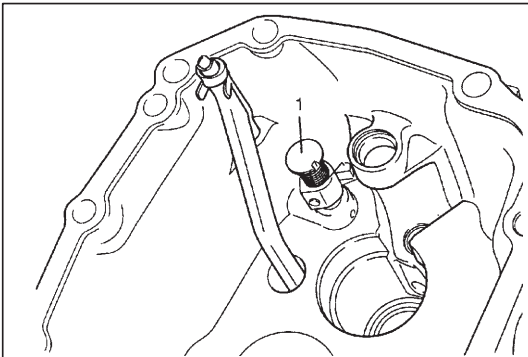

4) Pull out interlock cam component (1).

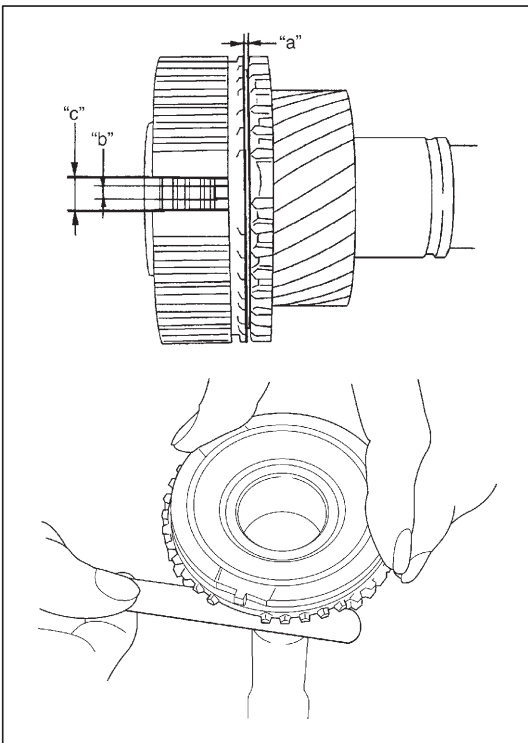

COMPONENTS INSPECTION

INPUT SHAFT ASSEMBLY

Check clearance "a" between synchronizer ring and gear, width of index protrusion "b" in synchronizer ring, key slot width "c" in high speed synchronizer hub and each chamfered tooth of gear and synchronizer ring and replace with new one, if necessary. Also, check gear tooth.

Clearance "a" between synchronizer ring and gear (input shaft):

Standard: 0.7 – 1.7 mm (0.028 – 0.067 in.)

Service limit: 0.5 mm (0.020 in.)

Width of index protrusion "b" (input shaft):

Standard: 3.6 – 3.8 mm (0.142 – 0.150 in.)

Service limit: 3.4 mm (0.134 in.)

Key slot width "c" (high speed synchronizer hub):

Standard: 8.0 – 8.1 mm (0.315 – 0.139 in.)

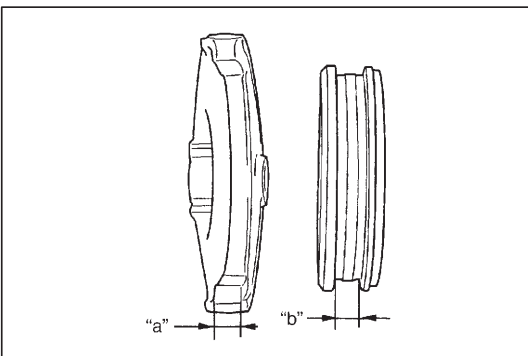
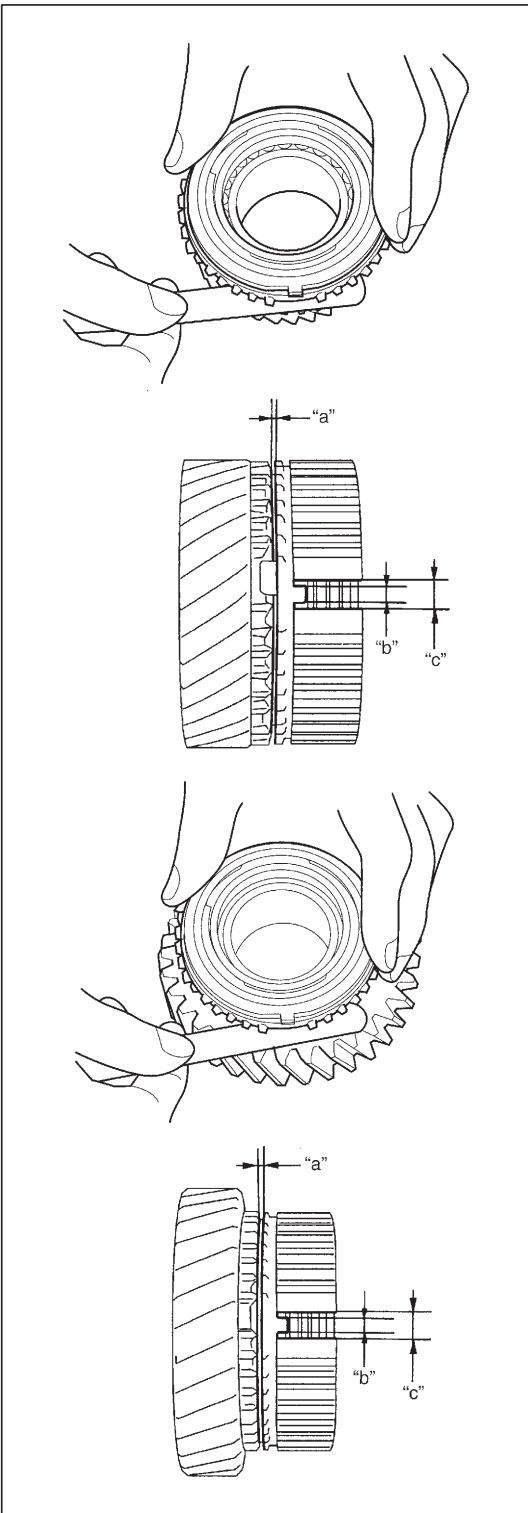

MAIN SHAFT ASSEMBLY

Check clearance "a" between synchronizer ring and gear, width of index protrusion "b" in synchronizer ring, key slot width "c" in high and low speed synchronizer hub and each chamfered tooth of gear and synchronizer ring and replace with new one, if necessary. Also, check gear tooth.

Clearance "a" between synchronizer ring and gear (Main shaft):

1st:

Standard: 0.7 – 1.7 mm (0.028 – 0.067 in.)

Service limit: 0.5 mm (0.020 in.)

2nd:

Standard: 0.7 – 1.5 mm (0.028 – 0.060 in.)

Service limit: 0.5 mm (0.020 in.)

3rd:

Standard: 0.7 – 1.2 mm (0.028 – 0.047 in.)

Service limit: 0.5 mm (0.020 in.)

Width of index protrusion "b" (Main shaft):

1st:

Standard: 4.2 – 4.6 mm (0.165 – 0.181 in.)

Service limit: 4.0 mm (0.157 in.)

2nd:

Standard: 5.0 – 5.2 mm (0.197 – 0.205 in.)

Service limit: 4.8 mm (0.189 in.)

3rd:

Standard: 4.8 – 5.0 mm (0.189 – 0.197 in.)

Service limit: 4.6 mm (0.181 in.)

Key slot width "c" (High and low speed synchronizer hub):

Standard: 8.0 – 8.1 mm (0.315 – 0.319 in.)

- Measure width of high and low gear shift fork ends "a" and groove width of high and low speed synchronizer sleeve "b" and then calculate clearance "c".

If clearance exceeds limit, replace fork and sleeve.

Clearance "c" between fork and sleeve:

Standard: 0.3 – 0.5 mm (0.012 – 0.020 in.)

Limit: 1.0 mm (0.039 in.)

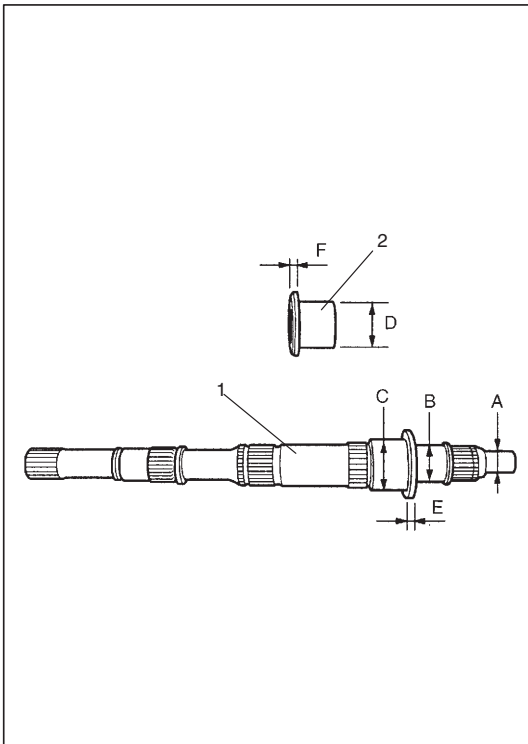

- Check diameter of main shaft (1)/needle bush (2) and thickness of main shaft (1)/needle bush (2) flanges as shown in the figure. If measured value is out of specification, replace them (or it).

Main shaft/needle bush specification (diameter and thickness):

Measuring portion	Standard
A	19.067 – 19.080 mm (0.7507 – 0.7512 in.)
B	31.969 – 31.985 mm (1.2586 – 1.2592 in.)
C	42.975 – 42.991 mm (1.6919 – 1.6926 in.)
D	42.975 – 42.991 mm (1.6919 – 1.6926 in.)
E	5.70 – 6.10 mm (0.2244 – 0.2402 in.)
F	4.78 – 4.91 mm (0.1882 – 0.1933 in.)

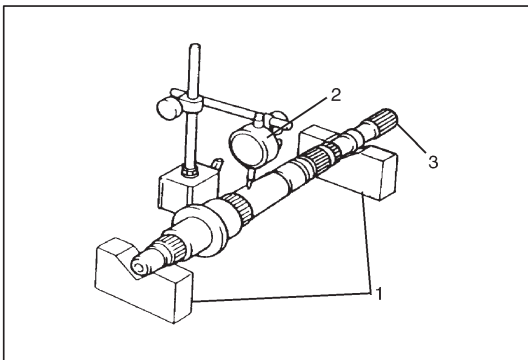

- Using “V” blocks (1) and dial gauge (2), check runout. If runout exceeds limit below, replace main shaft (3).

Main shaft runout: limit: 0.06 mm (0.0023 in.)

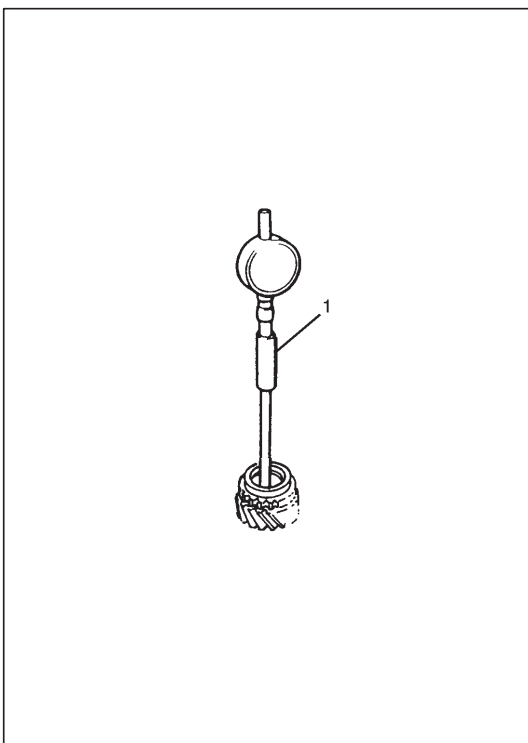

- Using cylinder gauge (1), check inside diameter of each gear. If its inside diameter exceeds specification, replace it.

Inside diameter of gear:

	Standard
1st, 2nd gear	49.000 – 49.025 mm (1.9291 – 1.9301 in.)
3rd gear	38.007 – 38.028 mm (1.4963 – 1.4972 in.)

- Check chamfered part of each sleeve for damage and excessive wear, and replace as necessary.
- Check each synchronizer key and synchronizer spring and replace as necessary.
- Check splined portions and replace parts if excessive wear is found.

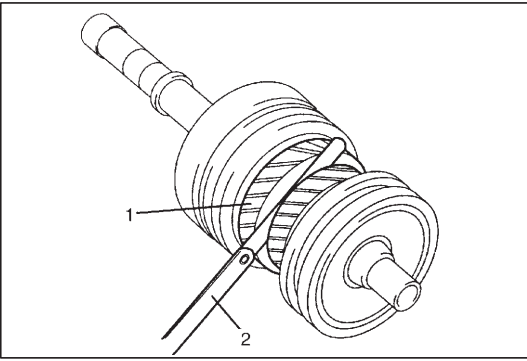

- Check 2nd gear (1) thrust clearance by using thickness gauge (2). If clearance is out of specification, repress or replace weary part.

2nd gear thrust clearance:

Standard: 0.10 – 0.25 mm (0.004 – 0.009 in.)

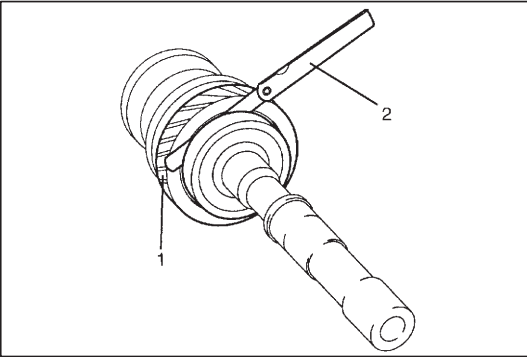

- Check low gear (1) thrust clearance by using thickness gauge (2). If clearance is out of specification, repress or replace weary part.

Low gear thrust clearance:

Standard: 0.10 – 0.25 mm (0.004 – 0.009 in.)

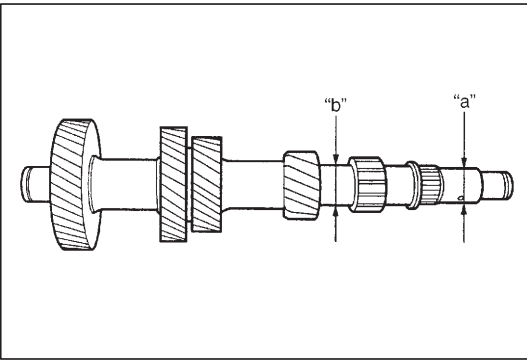

COUNTER SHAFT AND REVERSE IDLE GEAR

- Using micrometer, check diameter of counter shaft as shown in the figure. If measured value is out of specification, replace it.

Counter shaft diameter (standard):

“a”: 26.975 – 26.991 mm (1.0620 – 1.0626 in.)

“b”: 29.95 – 29.97 mm (1.1791 – 1.1799 in.)

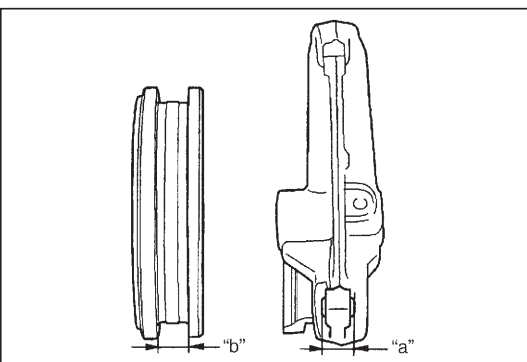

- Measure width of 5th reverse gear shift fork end “a” and groove width of 5th reverse gear synchronizer sleeve “b” and then calculate clearance “c”.

If clearance exceeds limit, replace fork and sleeve.

Clearance “c” between fork and sleeve:

Standard: 0.26 – 0.84 mm (0.010 – 0.033 in.)

Limit: 1.0 mm (0.039 in.)

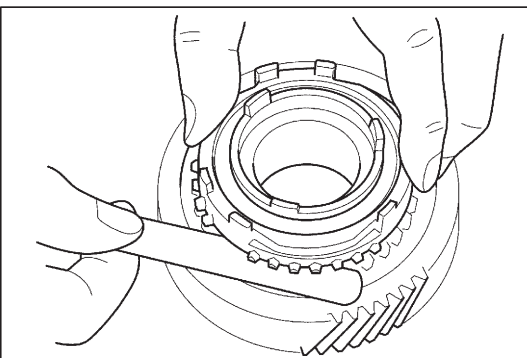

- Check clearance between synchronizer ring and gear and each chamfered tooth of gear and synchronizer ring and replace with new one, if necessary. Also, check gear tooth.

Clearance between synchronizer ring and gear (counter shaft):

Standard: 0.8 – 1.6 mm (0.031 – 0.063 in.)

Service limit: 0.5 mm (0.020 in.)

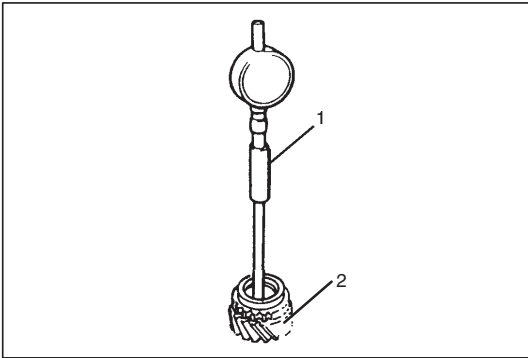

- Using cylinder gauge (1), check inside diameter of counter shaft 5th gear (2). If measured value exceeds specification, replace gear.

Counter shaft 5th gear diameter:

Standard: 33.000 – 33.025 mm (1.2992 – 1.3002 in.)

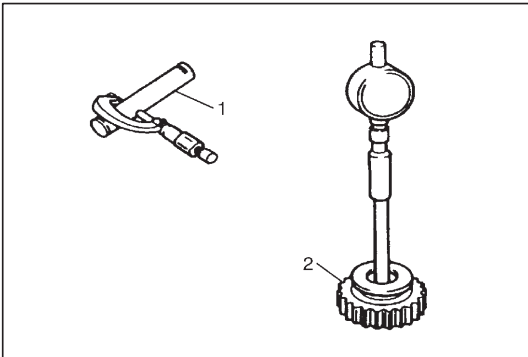

- Check oil clearance between reverse idle gear (2) and shaft (1) by measuring inside diameter of gear and diameter of shaft and calculate its clearance.

If clearance exceeds limit, replace gear and shaft.

Oil clearance between reverse idle gear and shaft

Standard: 0.041 – 0.074 mm (0.0016 – 0.0029 in.)

Limit: 0.13 mm (0.005 in.)

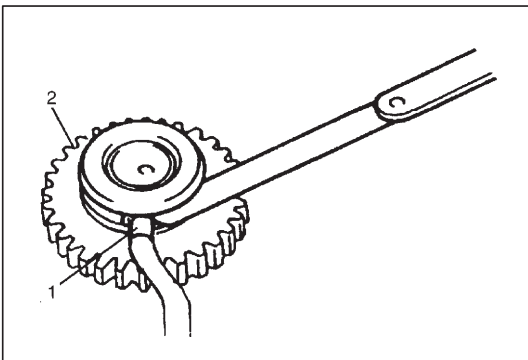

- Check clearance between reverse idle gear (2) and end (1) of reverse gear shift link.

If clearance exceeds limit, replace shoe.

Clearance between reverse idle gear and shoe

Standard: 0.05 – 0.35 mm (0.002 – 0.014 in.)

Limit: 0.7 mm (0.028 in.)

UNIT ASSEMBLY

GEAR SHIFT LEVER CASE ASSEMBLY

- 1) Wash and inspect each part and replace if necessary. Also check item as described below and correct whatever necessary carefully by using reamer, oilstone and the like, wash it thoroughly and reassemble it.

Item to be checked is;

- Shift shaft should go into case smoothly.

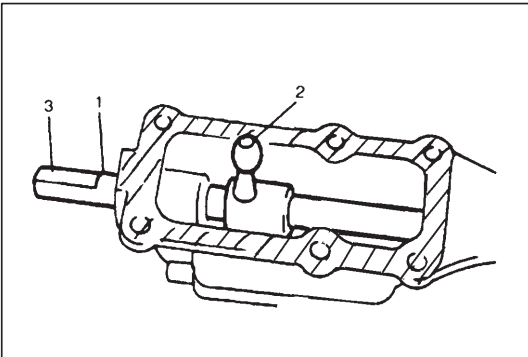

- 2) Insert shift shaft (1) as shown in the figure while making sure that inner parts are in proper direction.

NOTE:

- Cut off portion (3) in shift shaft (1) should face downward when shift shaft (1) is installed.
- Shift lever (2) should be installed at the same time.

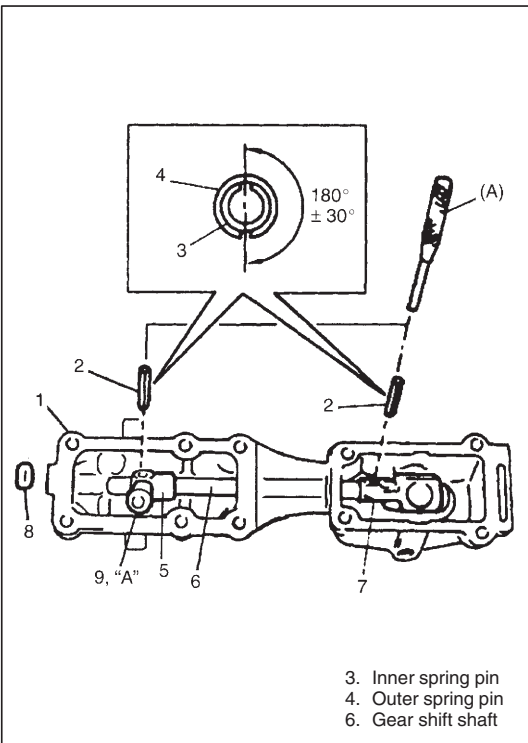

- 3) Drive in new spring pins (2) for gear shift lever (5) and shift arm (7).

NOTE:

When driving in spring pins, position their slits $180^\circ \pm 30^\circ$ apart.

Special Tool

(A): 09925-78210

- 4) Drive new case plug (8) into lever case (1).
- 5) Apply grease to shift lever bush (9) and install it.

“A”: Grease 99000-25010

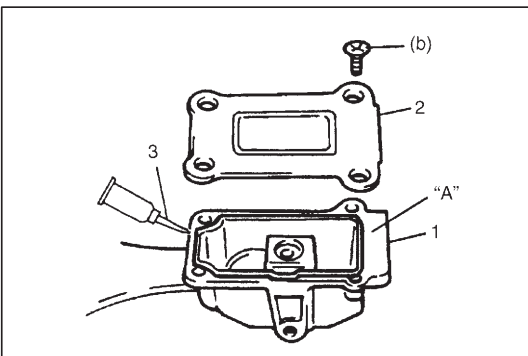

- 6) Clean mating surface of gear shift lever case (1) and case plate (2), and then apply sealant evenly to surface of gear shift lever case (1) by using a nozzle (3) as shown in the figure by such amount that its section is 1.5 mm (0.059 in.) in diameter.

“A”: Sealant 99000-31110

- 7) Tighten screws to specified torque.

Tightening torque

Gear shift lever case plate screws (b):

6 N·m (0.6 kg-m, 4.5 lb-ft)

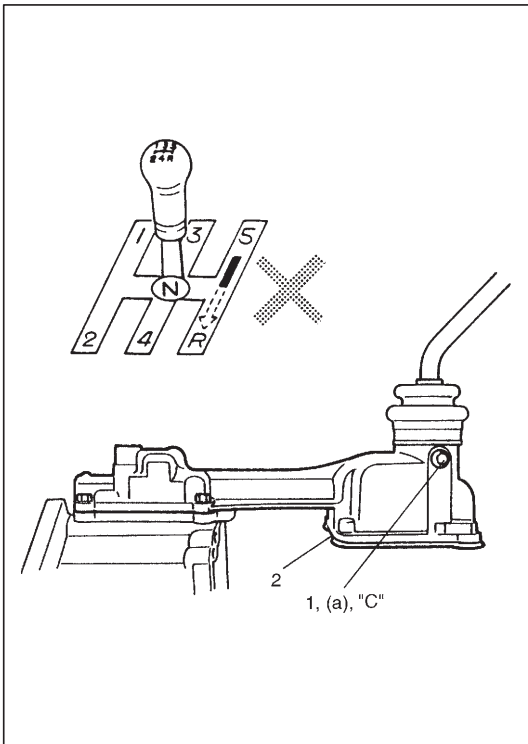

- 8) Install gear shift lever case (2) to transmission without using sealant for functional check.
- 9) Install shift control lever and check to make sure that it shifts smoothly according to shift pattern as shown in the figure.

NOTE:

- Apply thread lock cement “C” to control lever locating bolts (1) when retightening.
- Be sure to apply sealant to mating surface of gear shift lever case (2) for its final installation.

“C”: Cement 99000-32110

Tightening torque

Control lever locating bolts (a):
 17 N·m (1.7 kg·m, 12.5 lb-ft)

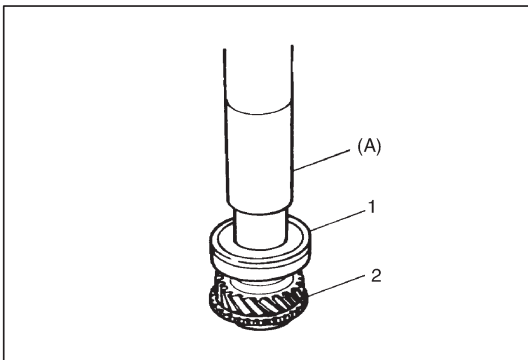

INPUT SHAFT ASSEMBLY

- 1) Bring bearing (1) so that its groove for circlip is in the front of input shaft (2) and press-fit with special tool and press.

Special tool

(A): 09940-51710

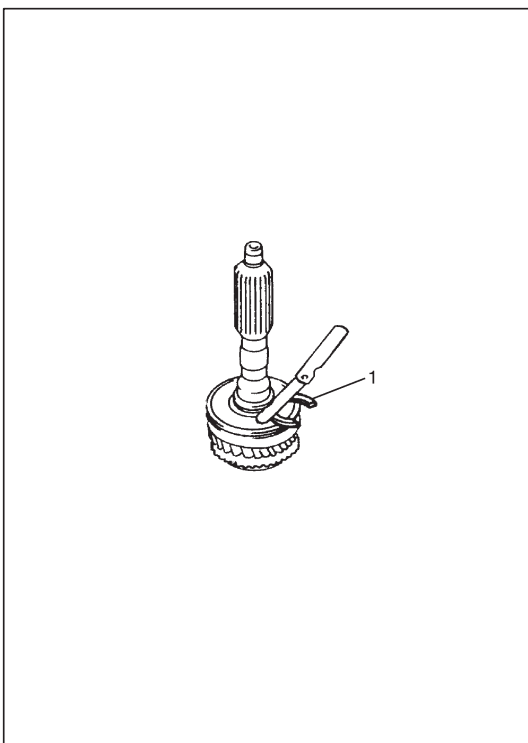

- 2) Select circlip (1) that will make thrust clearance of bearing 0.1 mm (0.0039 in) or less and install it.

Circlip thickness specification:

ID mark	Circlip thickness
1	2.05 – 2.10 mm (0.0807 – 0.0826 in.)
2	2.10 – 2.15 (0.0826 – 0.0846 in.)
3	2.15 – 2.20 (0.0846 – 0.0866 in.)
4	2.20 – 2.25 (0.0866 – 0.0885 in.)
5	2.25 – 2.30 (0.0885 – 0.0905 in.)
11	2.30 – 2.35 (0.0905 – 0.0925 in.)
12	2.35 – 2.40 (0.0925 – 0.0944 in.)

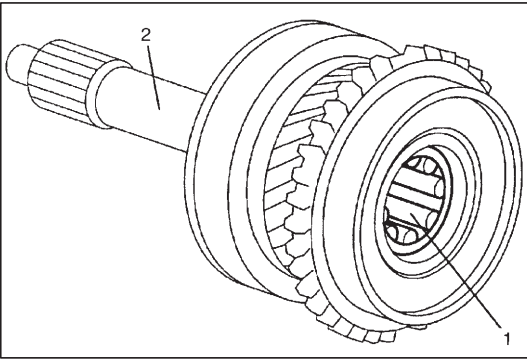

3) Apply grease to bearing roller (1) and install it to input shaft (2).

Grease: 99000-25010

MAIN SHAFT ASSEMBLY

NOTE:

- Before installation, wash each part and apply specified gear oil to sliding faces of bearing and gear.
- Use new circlips on shaft for installation. Don't reuse circlips.

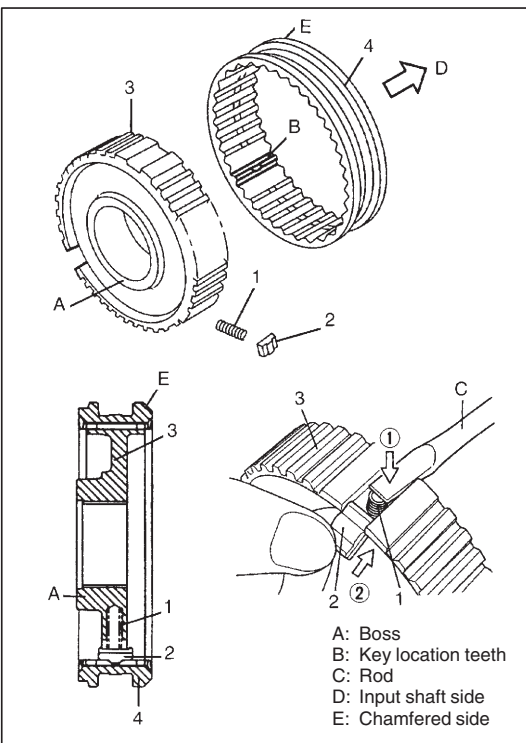

1) Assemble high speed synchronizer hub (3), sleeve (4), springs (1) and keys (2) according to the following procedure.

- Install compression springs (1) and shifting keys (2) to high speed synchronizer hub (3) as shown in the figure.
- Slide hub (3) in sleeve (4) so that chamfered side of sleeve (4) and boss side of hub (3) face opposite as shown in the figure, also aligning hub slots with key location teeth of sleeve (4).

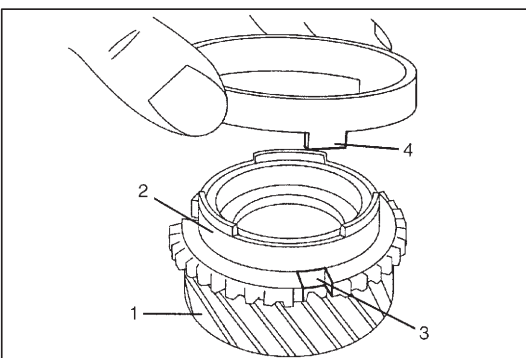

2) Assemble 3rd gear (1), synchronizer inner ring (2), synchronizer cone ring (4) and synchronizer outer ring according to the following procedure.

- Install the synchronizer inner ring (2) to 3rd gear (1), mating groove of 3rd gear (3) with protrusion of synchronizer cone ring (4), then attach synchronizer cone ring to 3rd gear as shown in the figure.

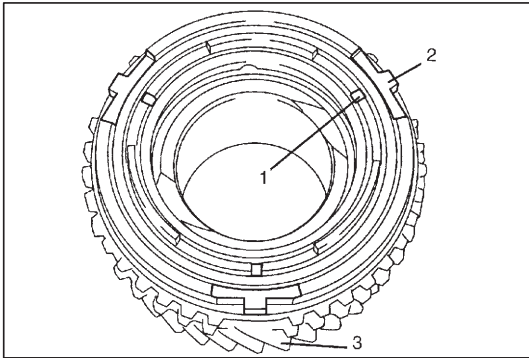

b) Align protrusion of synchronizer outer ring (2) into groove of synchronizer inner ring (1), then install synchronizer outer ring to 3rd gear (3) as shown in the figure.

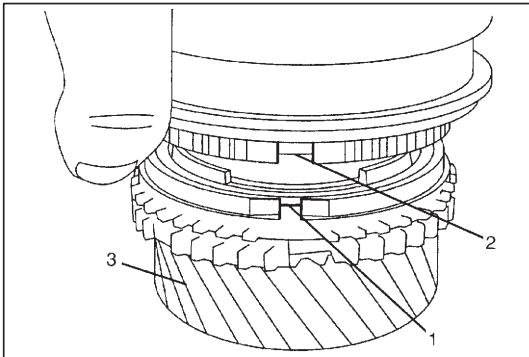

c) Align protrusion of synchronizer outer ring (1) into slot of synchronizer hub (2), and then attach high speed synchronizer sleeve and hub assembly to 3rd gear (3).

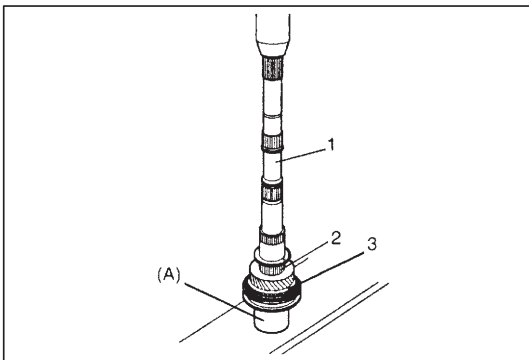

3) Install needle bearing (2) to main shaft (1) and press fit 3rd gear high speed synchronizer sleeve and hub assembly (3), which was assembled in step "a" through "c", to main shaft (1) using special tool.

Special tool
(A): 09940-53111

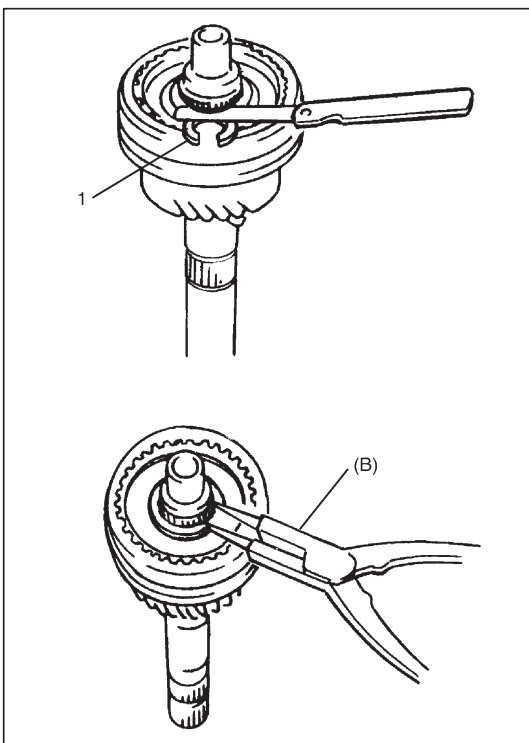

4) Select circlip (1) that will make thrust clearance of clutch hub 0.1 mm (0.0039 in.) or less and install it.

Circlip thickness specification:

ID mark	Circlip thickness
C - 1	1.75 - 1.80 mm (0.0689 - 0.0708 in.)
D	1.80 - 1.85 mm (0.0708 - 0.0728 in.)
11	1.86 - 1.91 mm (0.0729 - 0.0751 in.)
12	1.92 - 1.97 mm (0.0752 - 0.0775 in.)
13	1.98 - 2.03 mm (0.0776 - 0.0799 in.)
14	2.04 - 2.09 mm (0.0800 - 0.0822 in.)
15	2.10 - 2.15 mm (0.0823 - 0.0846 in.)

Special tool
(B): 09900-06107

5) After installing circlip, check that 3rd gear turns lightly.

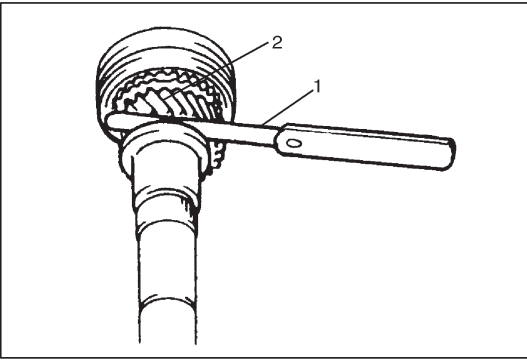

- 6) Check 3rd gear (2) thrust clearance by using thickness gauge (1). If clearance is out of specification, repress or replace weary part.

3rd gear thrust clearance:

Standard: 0.10 – 0.25 mm (0.004 – 0.009 in.)

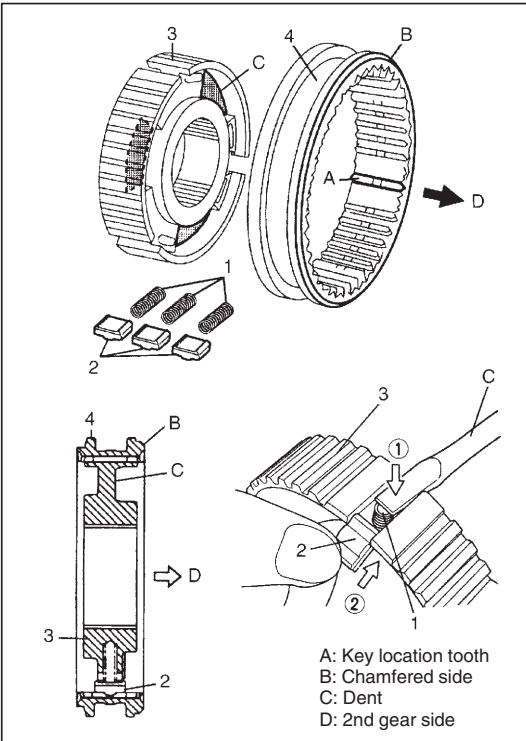

- 7) Assemble low speed synchronizer hub (3), sleeve (4), springs (1) and keys (2) according to the following procedure.
- Install compression springs (1) and shifting keys (2) to low speed synchronizer hub (3) as shown in the figure.
 - Slide low speed synchronizer hub (3) in sleeve (4) so that chamfered side of sleeve (4) and dent side of hub (3) face opposite as shown in the figure, also aligning hub slots with key location teeth of sleeve (4).

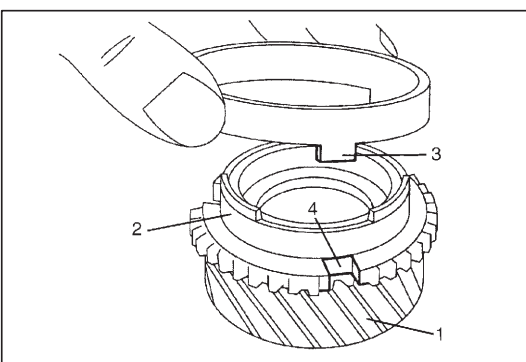

- 8) Assemble 2nd gear (1), synchronizer inner ring (2), synchronizer cone ring (3) and synchronizer outer ring according to the following procedure.

- Install synchronizer inner ring (2) to 2nd gear (1), fitting protrusion of synchronizer cone ring (3) into groove of 2nd gear (4), then attach synchronizer cone ring to 2nd gear as shown in the figure.

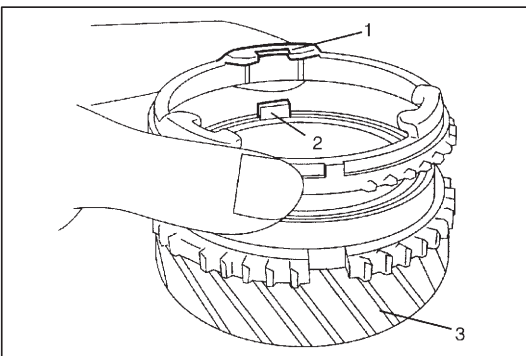

- Install synchronizer outer ring (1) to 2nd gear (3), fitting slot of synchronizer outer ring (1) in protrusion of synchronizer inner ring (2) as shown in the figure.

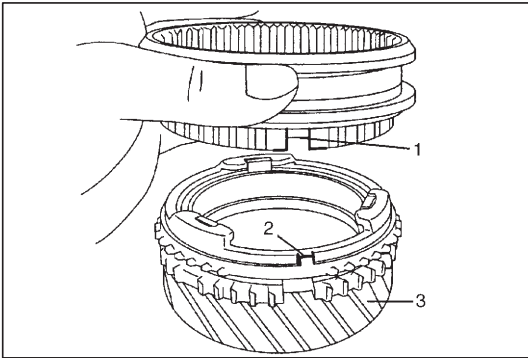

c) Install 2nd gear (3), fitting slot of low speed synchronizer hub (1) in protrusion of synchronizer outer ring (2) as shown in the figure.

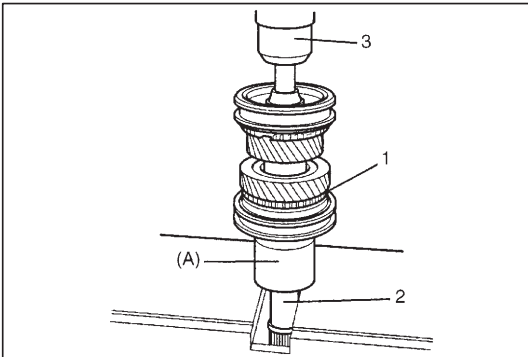

9) Install the needle bearing to the 2nd gear, then as the figure shows press fit 2nd gear low speed synchronizer sleeve and hub assembly (1), which was assembled in step "a" through "c", into main shaft (2) using a special tool. Press-fit low speed sleeve and hub assembly with special tool and press (3).

Special tool

(A): 09940-53111

10) Check 2nd gear thrust clearance, referring to "MAIN SHAFT ASSEMBLY" in this section.

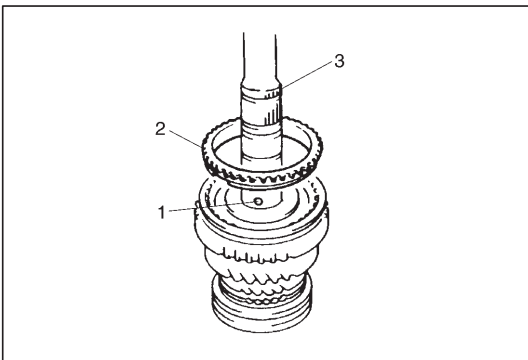

11) Apply grease to ball (1) and set it to main shaft (3).

12) Install synchronizer ring (2).

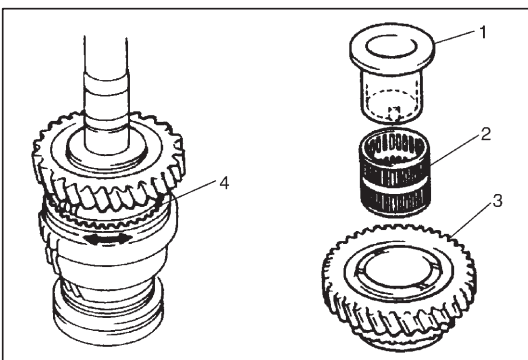

13) Install needle bearing (2), low gear (3) and needle bush (1) to main shaft.

NOTE:

- Check the cut in needle bush and ball are engaged.
- After installation, check synchronizer ring (4) moves in circumferential direction.

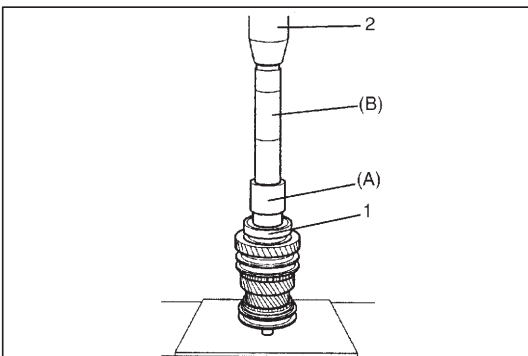

14) Press-fit main shaft bearing (1) with special tools and press (2).

NOTE:

Bring bearing so that its groove for circlip is in the rear.

Special tool

(A): 09940-53111

(B): 09940-51710

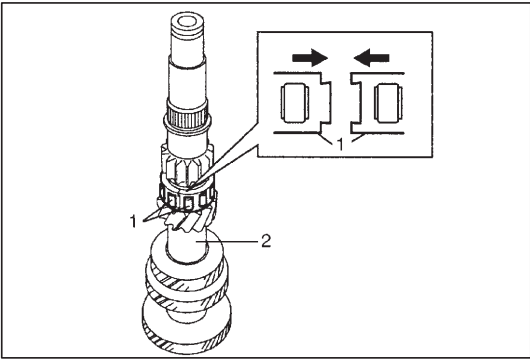

COUNTER SHAFT ASSEMBLY

1) Install counter shaft bearing (1) to counter shaft (2).

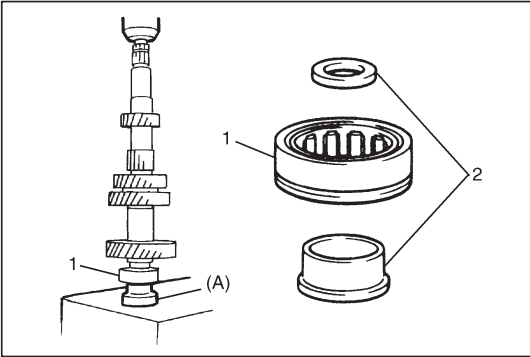

2) Set inner race (2) to counter shaft front bearing (1) and press-fit bearing with press and special tool.

NOTE:

When installing bearing, bring it so that its groove for circlip is in the front.

Special tool

(A): 09940-54950

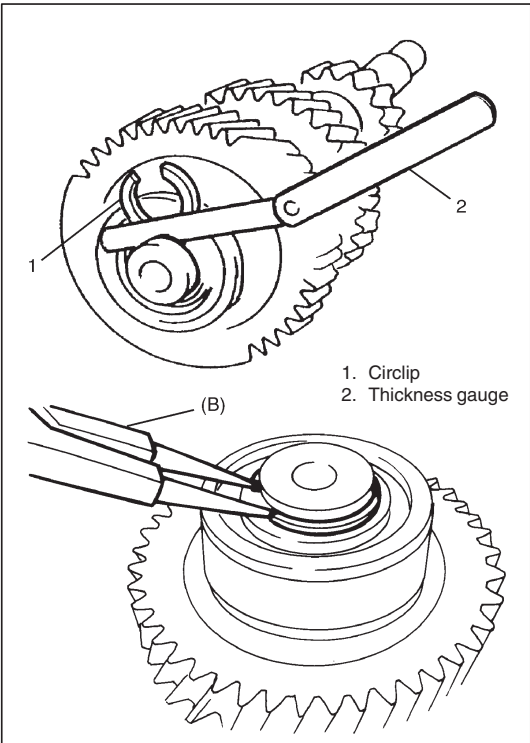

3) Select circlip that will make its thrust clearance 0.1 mm (0.0039 in.) or less and install it.

Circlip thickness specification:

ID mark	Circlip thickness
A	2.05 – 2.10 mm (0.0807 – 0.0826 in.)
B	2.10 – 2.15 mm (0.0826 – 0.0846 in.)
C	2.15 – 2.20 mm (0.0846 – 0.0866 in.)
D	2.20 – 2.25 mm (0.0866 – 0.0885 in.)
E	2.25 – 2.30 mm (0.0885 – 0.0905 in.)
F	2.30 – 2.35 mm (0.0905 – 0.0925 in.)

Special tool

(B): 09900-06107

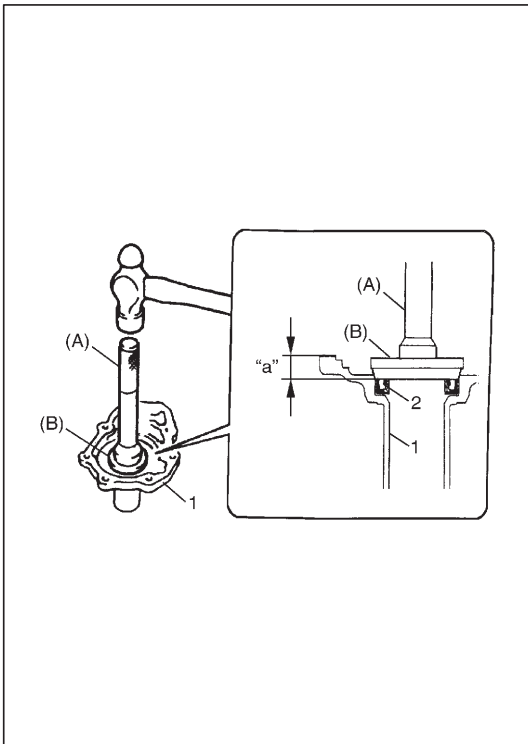

INPUT SHAFT BEARING RETAINER AND OIL SEAL

Install new oil seal (2) to bearing retainer (1) by using special tool as shown in the figure.

Apply grease to oil seal lip.

Grease: 99000-25010

Special tool

(A): 09913-75821

(B): 09924-84510-004

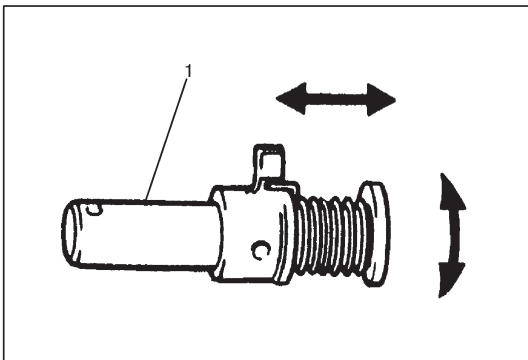

TRANSMISSION REAR CASE

1) Check that interlock cam component (1) moves smoothly in both turning direction and sliding direction.

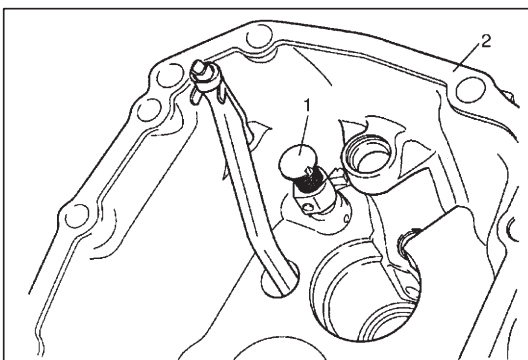

2) Insert interlock cam component (1) to rear case (2).

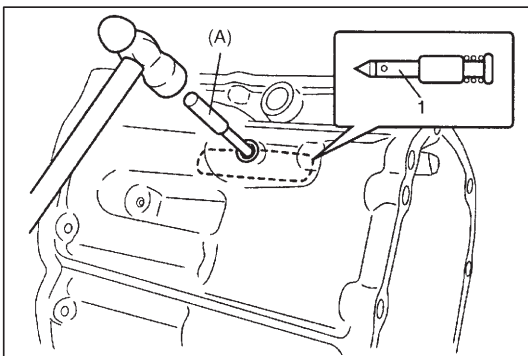

3) Set interlock cam component (1) as shown in the figure and drive pin by using special tool.

Special tool

(A): 09922-85811

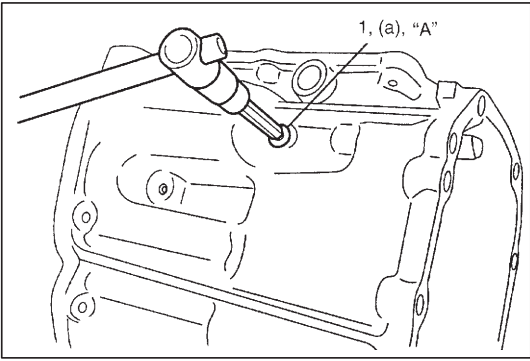

4) Apply sealant to thread of interlock cam plug (1) and tighten it to specification.

"A": Sealant 99000-31110

Tightening torque

Interlock cam plug (a): 25 N·m (2.5 kg-m, 18.0 lb-ft)

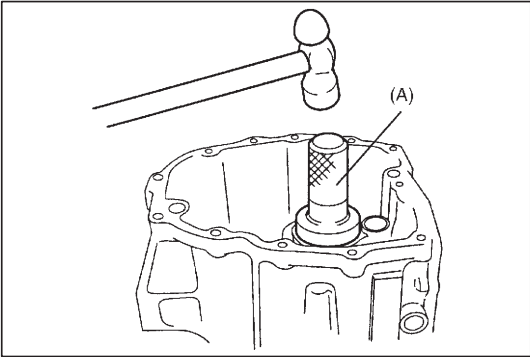

5) Install oil seal to rear case so that end surface of oil seal becomes flush with that case. Apply grease to oil seal lip.

Grease: 99000-25010

Special tool

(A): 09913-75520

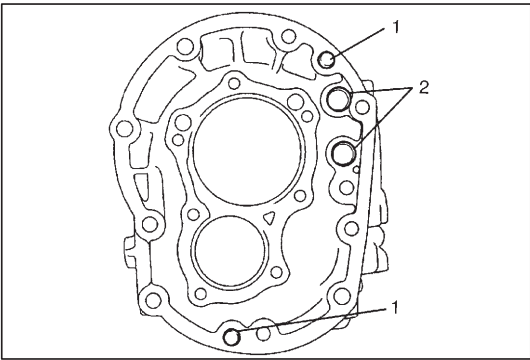

TRANSMISSION INTERMEDIATE CASE AND FRONT CASE (LOCATION OF KNOCK AND PLUG)

● Press knock pin (1) and plug (2) (knocking those in until perfect fit is achieved) into front case as shown.

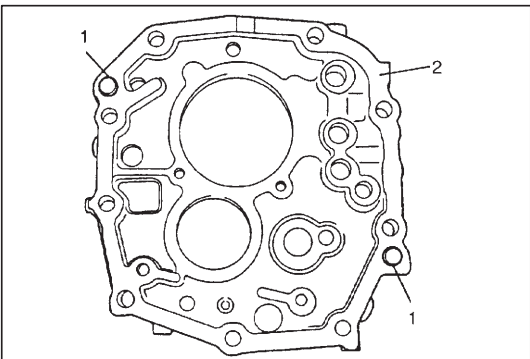

● Press knock pin (1) into intermediate case (2) as shown in the figure.

TRANSMISSION UNIT

NOTE:

- Before installation, wash each part and apply specified gear oil to sliding faces of bearing and gear.
- Use new circlips on shaft for installation. Don't reuse circlips.

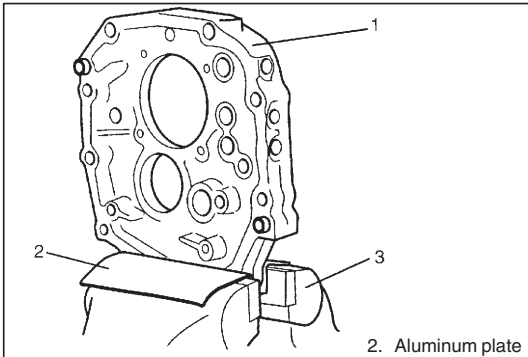

1) Set intermediate case (1) to vise (3).

Clean mating surfaces of intermediate case both sides, if intermediate case is reused.

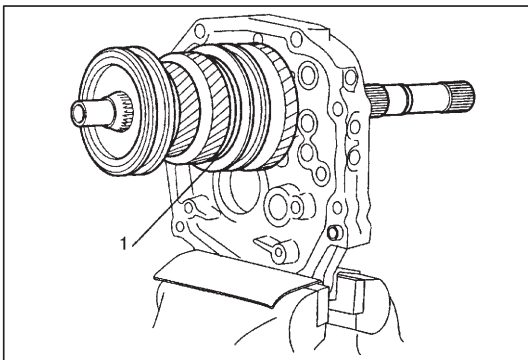

2) Install main shaft assembly (1) to intermediate case.

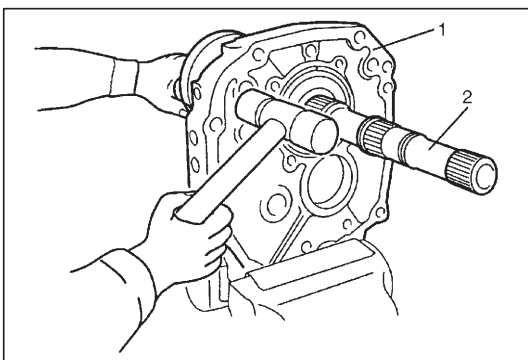

NOTE:

When fitting of intermediate case (1) and bearing is tight, tap rear face of intermediate case (1) with plastic hammer (2) lightly as it will cause main shaft assembly (2) to install.

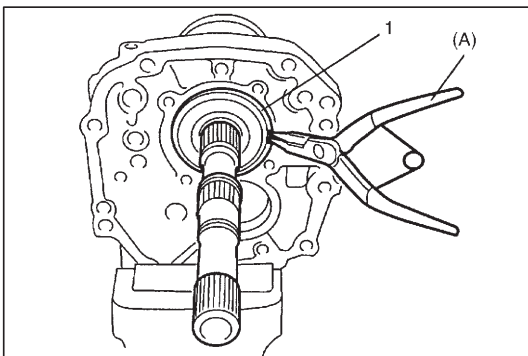

3) Fix bearing with new C-ring (1) by using special tool.

Special tool
(A): 09900-06107

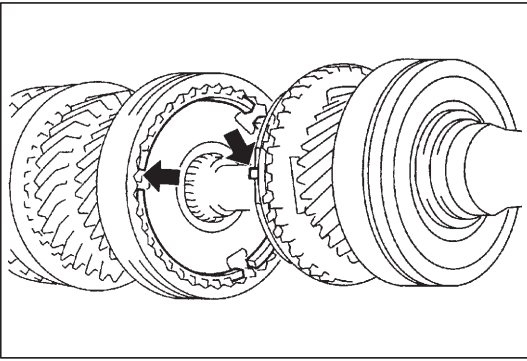

- 4) Align key slot of high speed synchronizer hub and protrusion of synchronizer ring and set input shaft assembly to main shaft assembly. Check that input assembly turns lightly.

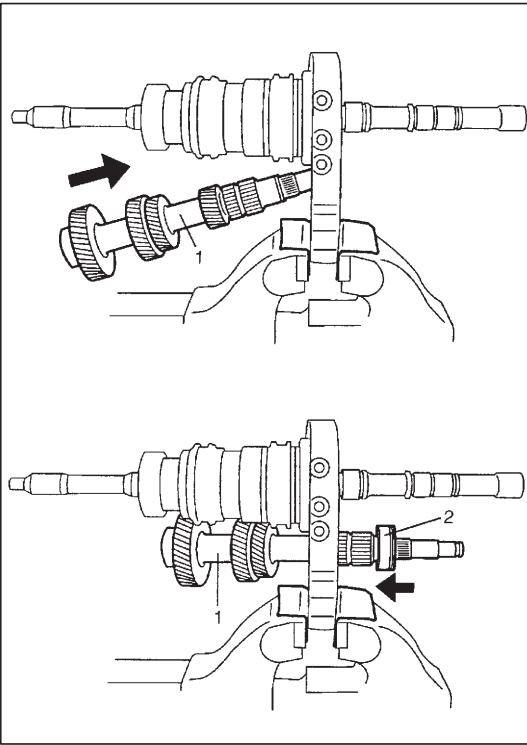

- 5) Install counter shaft (1) and counter shaft bearing outer race (2) to intermediate case.

NOTE:

- When installing bearing, bring it so that its C-ring side is at rear side of intermediate case as shown in the figure.
- When fitting of intermediate case and bearing is tight, tap outer race of bearing lightly and evenly with plastic hammer.

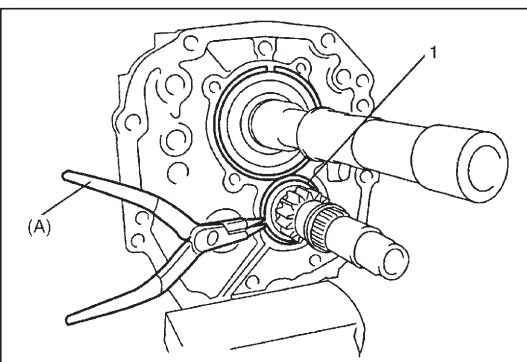

- 6) Fix bearing with new C-ring (1) by using special tool.

Special tool

(A): 09900-06107

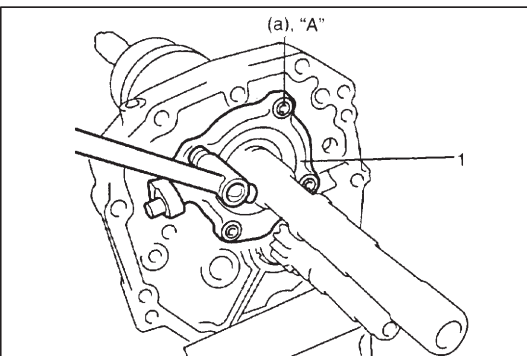

- 7) Install main and counter shaft bearing retainer (1).

“A”: Cement 99000-32110

Tightening torque

Main and counter shaft bearing retainer screws (a):

19 N·m (1.9 kg-m, 14.0 lb-ft)

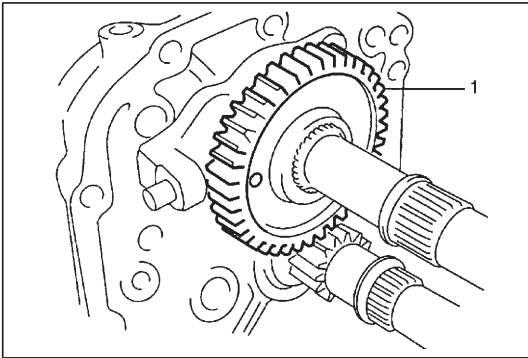

8) Install reverse gear (1).

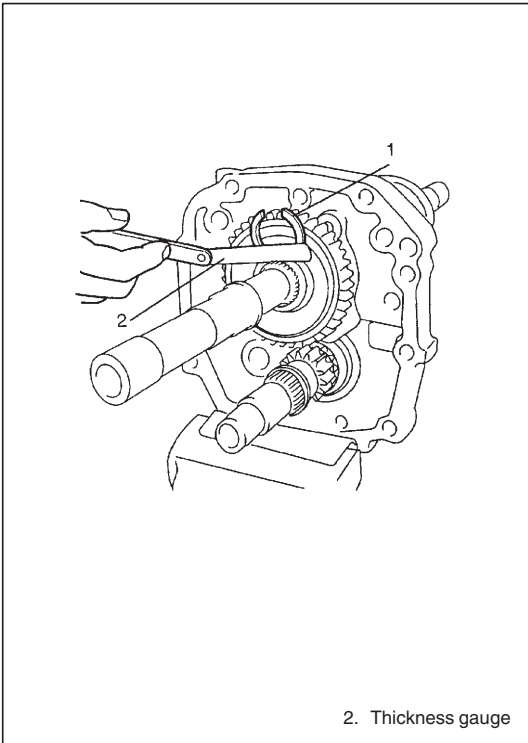

9) Select circlip (1) that will make its thrust clearance 0.1 mm (0.0039 in.) or less and install it.

Circlip thickness specification:

ID mark	Circlip thickness
5	2.25 – 2.30 mm (0.0886 – 0.0905 in.)
11	2.30 – 2.35 mm (0.0905 – 0.0925 in.)
12	2.35 – 2.40 mm (0.0925 – 0.0944 in.)
13	2.40 – 2.45 mm (0.0944 – 0.0964 in.)
14	2.45 – 2.50 mm (0.0964 – 0.0984 in.)
15	2.50 – 2.55 mm (0.0984 – 0.1003 in.)
16	2.55 – 2.60 mm (0.1003 – 0.1023 in.)
17	2.61 – 2.66 mm (0.1024 – 0.1047 in.)
18	2.67 – 2.72 mm (0.1048 – 0.1070 in.)
19	2.73 – 2.78 mm (0.1071 – 0.1094 in.)
20	2.79 – 2.84 mm (0.1095 – 0.1118 in.)
21	2.85 – 2.90 mm (0.1119 – 0.1141 in.)
22	2.91 – 2.96 mm (0.1142 – 0.1165 in.)
23	2.97 – 3.02 mm (0.1166 – 0.1188 in.)

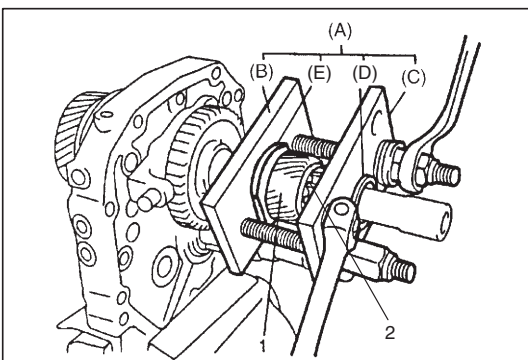

10) Install 5th gear (1) and output bearing (2) by using special tool.

Special tool

(A): 09926-36510

(B): 09926-36510-001

(C): 09926-36510-002

(D): 09926-36510-003

(E): 09926-36510-004

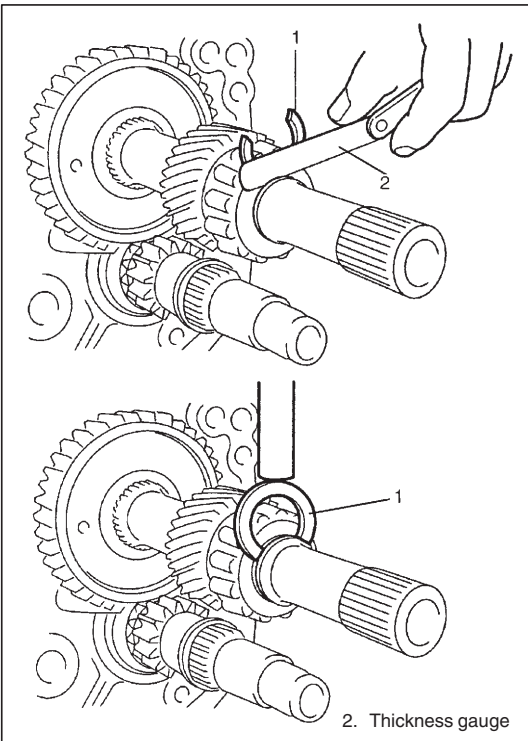

- 11) Select circlip (1) that will make its thrust clearance 0.1 mm (0.0039 in.) or less and install it.

Circlip thickness specification:

ID mark	Circlip thickness
8	2.31 – 2.36 mm (0.0909 – 0.0929 in.)
9	2.37 – 2.42 mm (0.0930 – 0.0952 in.)
10	2.43 – 2.48 mm (0.0953 – 0.0976 in.)
11	2.49 – 2.54 mm (0.0977 – 0.0999 in.)
12	2.55 – 2.60 mm (0.1000 – 0.1023 in.)
13	2.61 – 2.66 mm (0.1024 – 0.1047 in.)
14	2.68 – 2.73 mm (0.1055 – 0.1074 in.)
15	2.74 – 2.79 mm (0.1075 – 0.1098 in.)

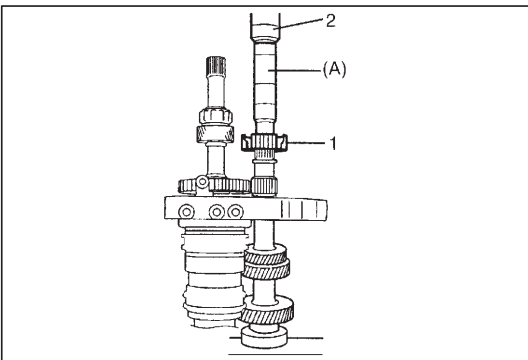

- 12) Press-fit 5th reverse synchronizer hub (1) to counter shaft with press (2) and special tool.

Special tool

(A): 09925-18011

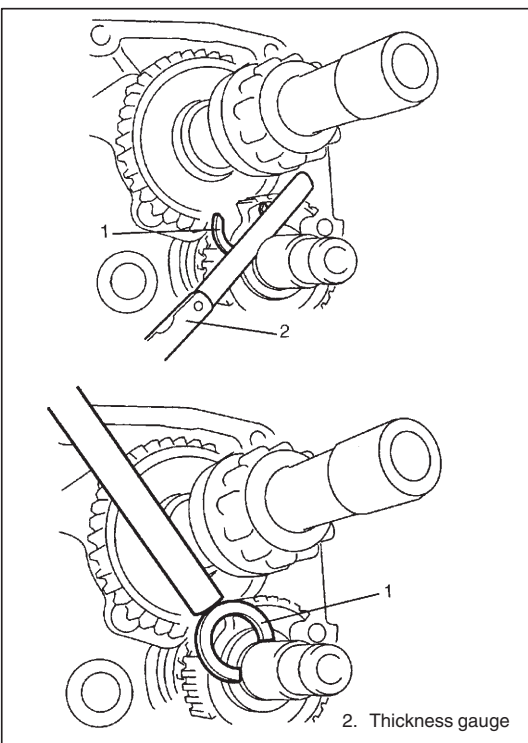

- 13) Select circlip (1) that will make its thrust clearance 0.1 mm (0.0039 in.) or less and install it.

Circlip thickness specification:

ID mark	Circlip thickness
2	2.06 – 2.11 mm (0.0811 – 0.0830 in.)
3	2.12 – 2.17 mm (0.0831 – 0.0854 in.)
4	2.18 – 2.23 mm (0.0855 – 0.0877 in.)
5	2.24 – 2.29 mm (0.0878 – 0.0901 in.)

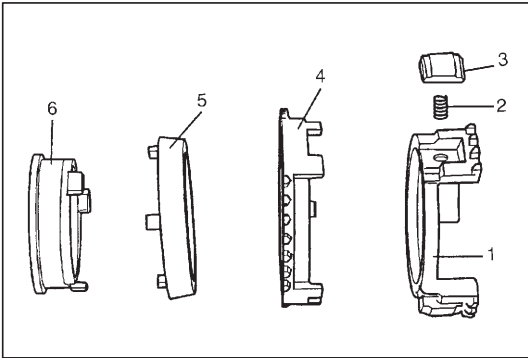

14) Assemble reverse brake ring (1), springs (2), keys (3), 5th gear synchronizer outer ring (4), 5th gear synchronizer cone ring (5) and 5th gear synchronizer pull ring (6) according to the following procedure.

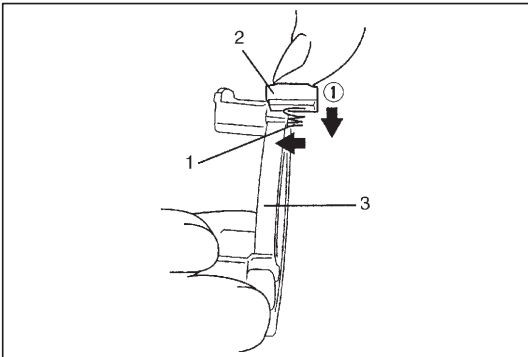

a) Install springs (1) and keys (2) to reverse brake ring (3) as shown in the figure.

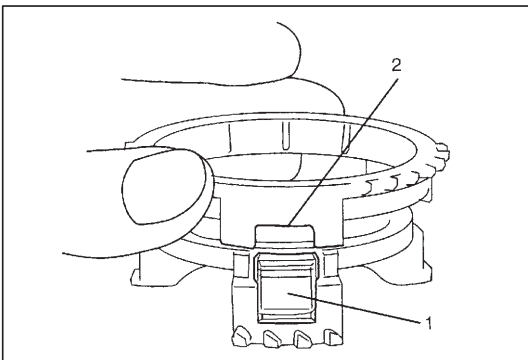

b) Install 5th gear synchronizer outer ring to reverse break ring, fitting key of the reverse break ring (1) into groove of 5th gear synchronizer outer ring (2) as the figure shows.

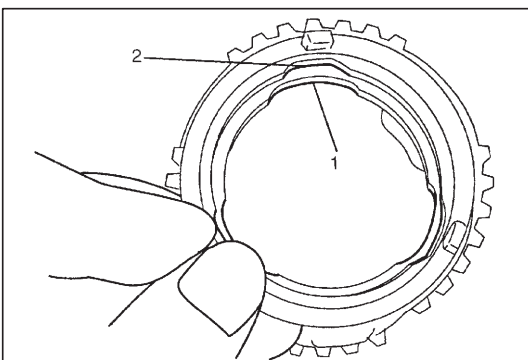

c) Install 5th gear synchronizer cone ring to 5th gear synchronizer outer ring, setting groove of 5th gear synchronizer outer ring (1) and groove of 5th gear synchronizer cone ring (2) in the same position.

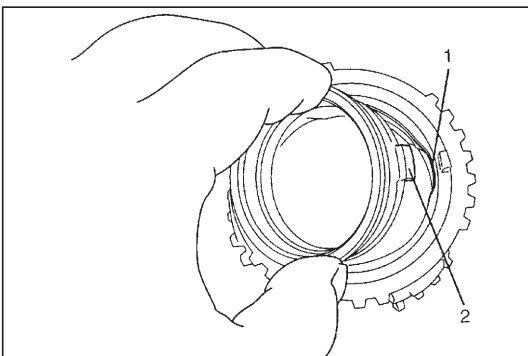

d) Install 5th gear synchronizer pull ring (2) to 5th gear synchronizer outer ring and cone ring assembly, fitting protrusion of 5th gear synchronizer pull ring (2) into groove of 5th gear synchronizer cone ring (1) as shown in the figure.

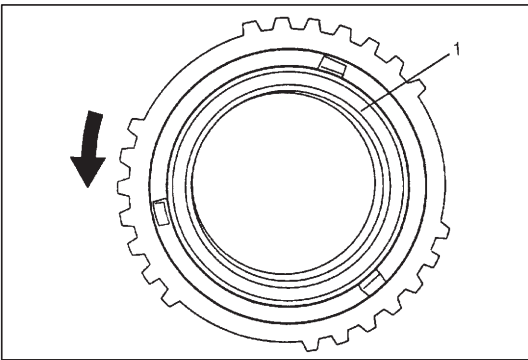

e) Turn 5th gear synchronizer pull ring (1) around 45 degrees as shown in the figure.

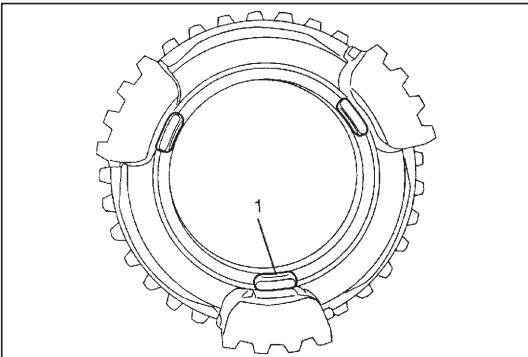

f) Make sure that position of 5th gear synchronizer pull ring protrusion (1) is in the same position as the figure shows. If it isn't, turn 5th gear synchronizer pull ring again, setting the same position as figure shows.

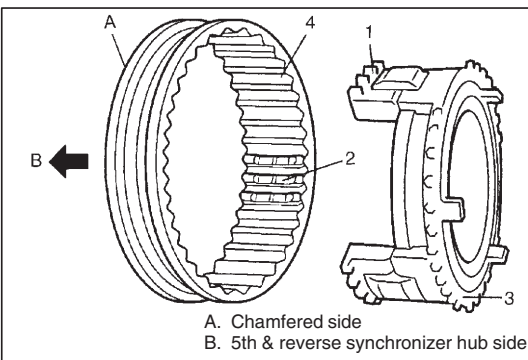

15) Attach 5th gear synchronizer ring assembly (3) to 5th & reverse synchronizer sleeve (4) so that spline teeth of 5th gear synchronizer ring assembly (1), which was assembled in step "a" through "f", and key location teeth of 5th reverse synchronizer sleeve (2) mesh.

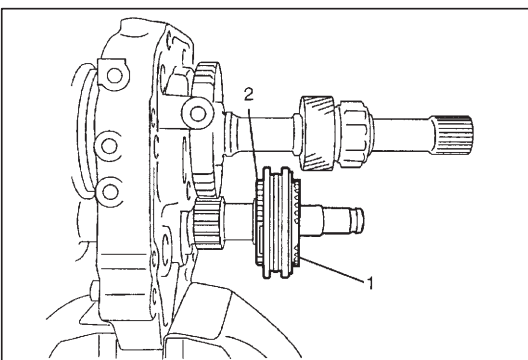

16) Install 5th & reverse synchronizer sleeve assembly (1), which was assembled in step 15), to 5th reverse synchronizer hub (2).

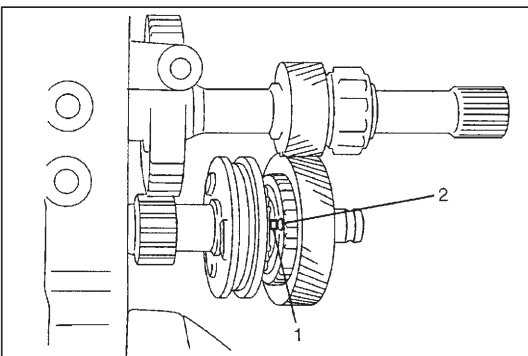

17) Install counter shaft 5th gear to counter shaft, fitting protrusion of 5th gear synchronizer cone ring (1) into hole of counter shaft 5th gear (2) as shown in the figure.

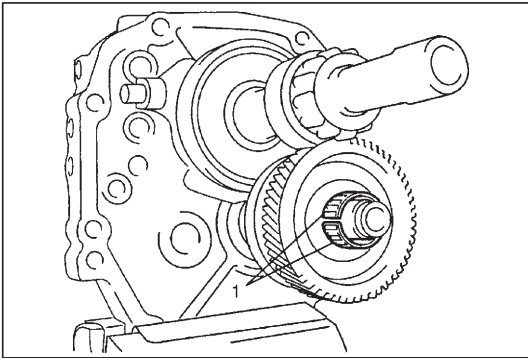

18) Install spacer and needle bearing (1).

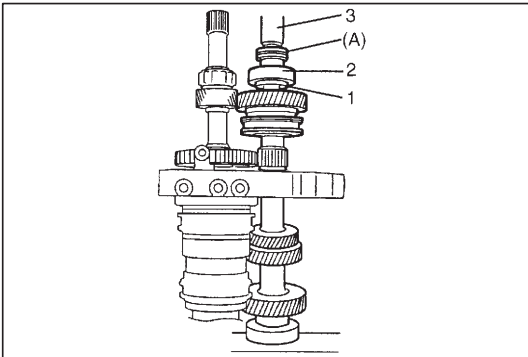

19) Press-fit thrust washer (1) and counter shaft bearing (2) to counter shaft with press (3) and special tool.

Special tool
(A): 09940-54950

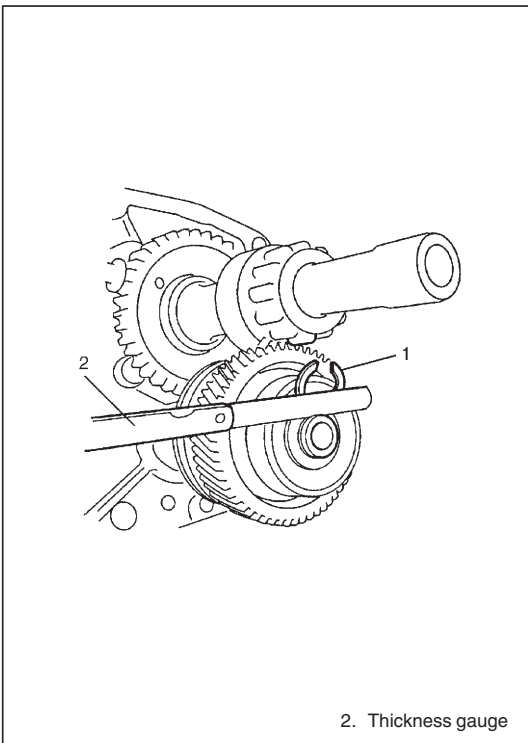

20) Select circlip (1) that will make its thrust clearance 0.1 mm (0.0039 in.) or less and install it.

Circlip thickness specification:

ID mark	Circlip thickness
1	1.90 – 1.95 mm (0.0748 – 0.0767 in.)
2	1.96 – 2.01 mm (0.0768 – 0.0791 in.)
3	2.02 – 2.07 mm (0.0792 – 0.0814 in.)
4	2.08 – 2.13 mm (0.0815 – 0.0838 in.)
5	2.14 – 2.19 mm (0.0839 – 0.0862 in.)
6	2.20 – 2.25 mm (0.0863 – 0.0885 in.)
7	2.26 – 2.31 mm (0.0886 – 0.0909 in.)

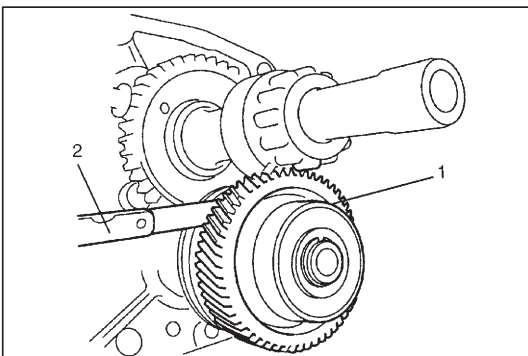

21) Check counter 5th gear (1) thrust clearance by using thickness gauge (2).

Counter 5th gear thrust clearance:
Standard: 0.1 – 0.3 mm (0.0040 – 0.0118 in.)

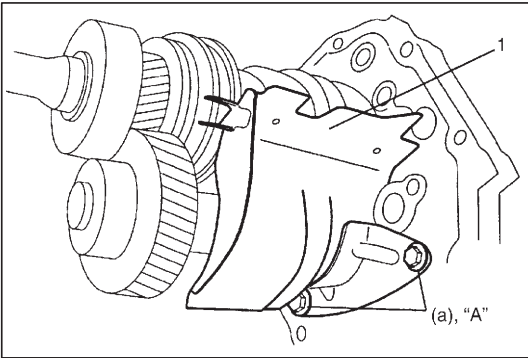

22) Install oil plate (1) to intermediate case.

“A”: Cement 99000-32110

Tightening torque

Oil plate mounting bolts (a): 19 N·m (1.9 kg-m, 14.0 lb-ft)

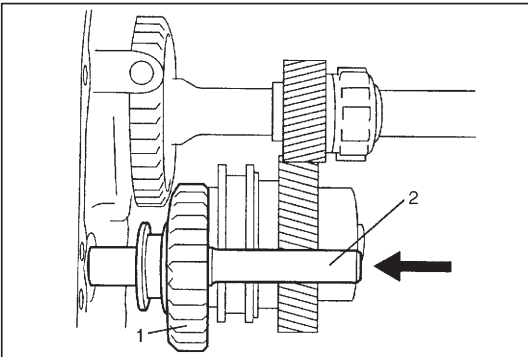

23) Insert reverse idler shaft (2) into reverse idler gear (1) and intermediate case.

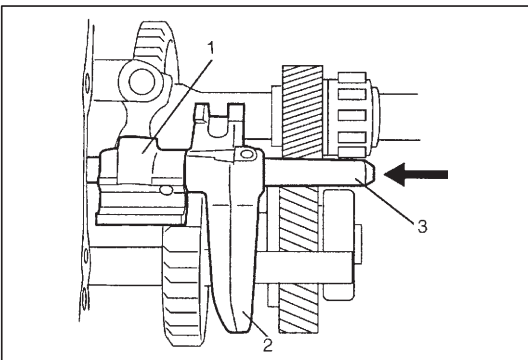

24) Insert 5th gear shift shaft (3) into 5th gear shift fork (2), reverse gear shift link comp. (1) and intermediate case.

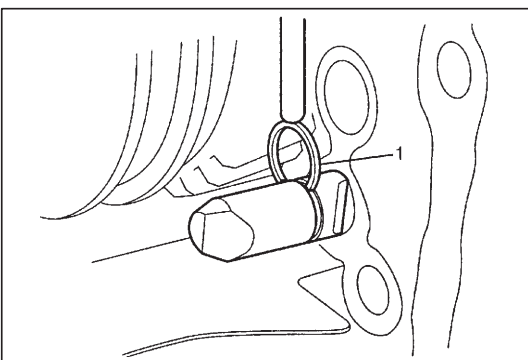

25) Fix new circlip (1) to 5th gear shift shaft by using rod or the like and hammer.

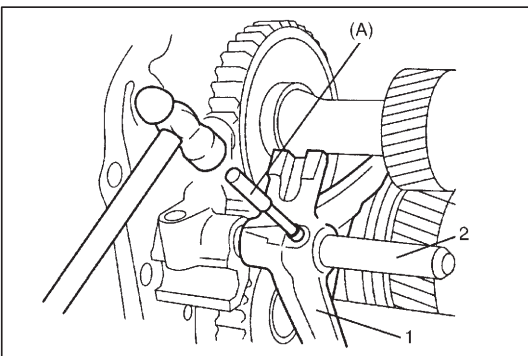

26) Drive pin into 5th gear shift fork (1) and 5th gear shift shaft (2) by using special tool.

Special tool

(A): 09922-85811

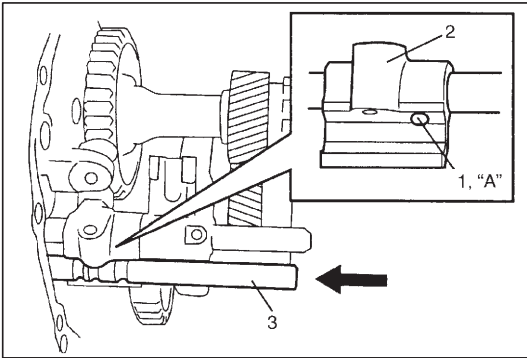

27) Apply grease to straight pin (1) and install straight pin (1) to reverse gear shift link comp. (2).

“A”: Grease 99000-25010

28) Insert 5th reverse guide shaft (3) into intermediate case.

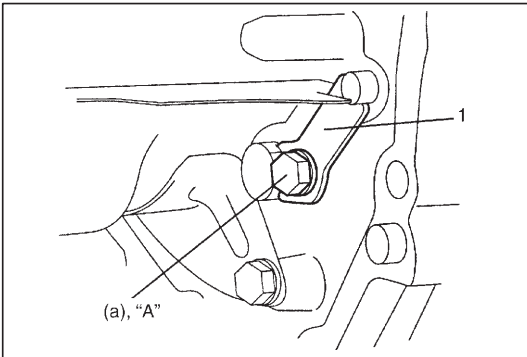

29) Install stopper (1) to intermediate case.

“A”: Cement 99000-32110

Tightening torque

Stopper mounting bolt (a): 25 N·m (2.5 kg-m, 18.0 lb-ft)

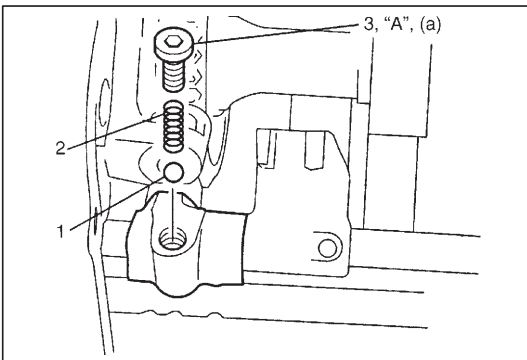

30) Install ball (1), compression spring (2) and straight plug (3).

“A”: Cement 99000-32110

Tightening torque

Straight plug (a): 25 N·m (2.5 kg-m, 18.0 lb-ft)

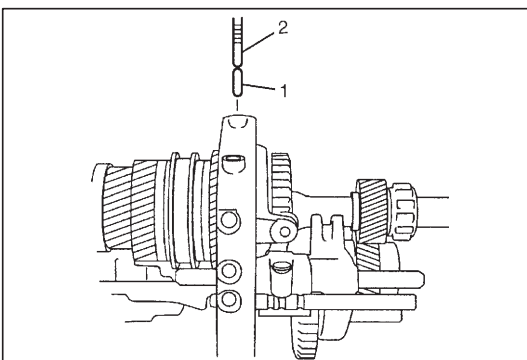

31) Install interlock pin (1) by using magnet (2).

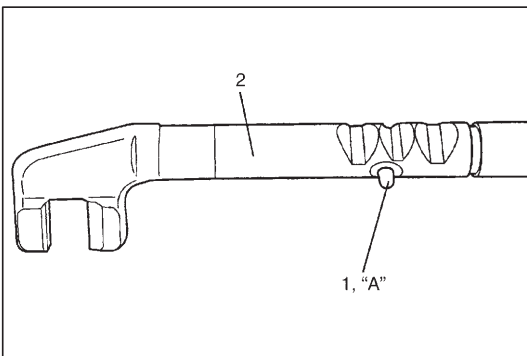

32) Apply grease to straight pin (1) and install straight pin (1) to high gear shift shaft (2).

“A”: Grease 99000-25010

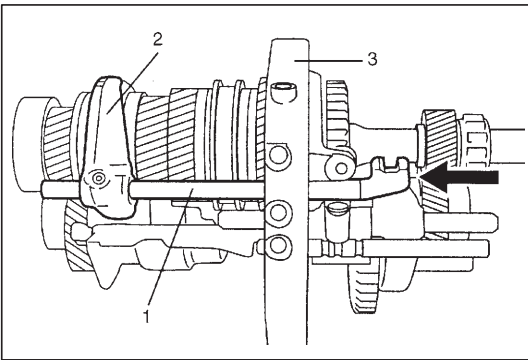

33) Insert high gear shift shaft (1) into intermediate case (3) and high speed gear shift fork (2).

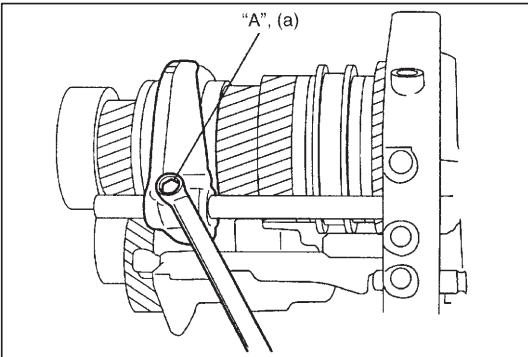

34) Apply thread lock cement to thread of fork bolt and tighten bolt to specification.

“A”: Cement 99000-32110

Tightening torque

High speed gear shift fork bolt (a):
20 N·m (2.0 kg·m, 14.5 lb·ft)

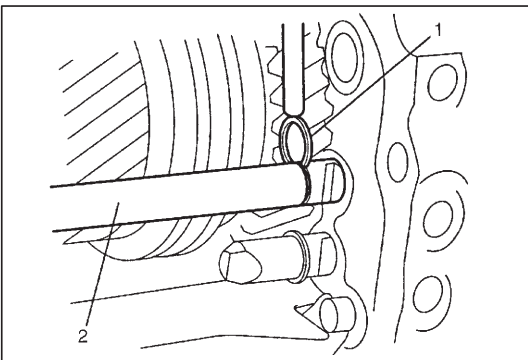

35) Install new circlip (1) to high gear shift shaft (2) by using lever or the like and hammer.

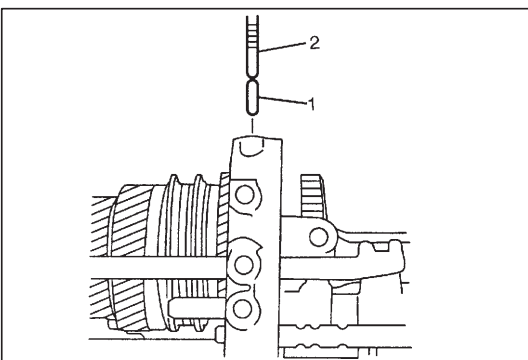

36) Install interlock pin (1) by using magnet (2).

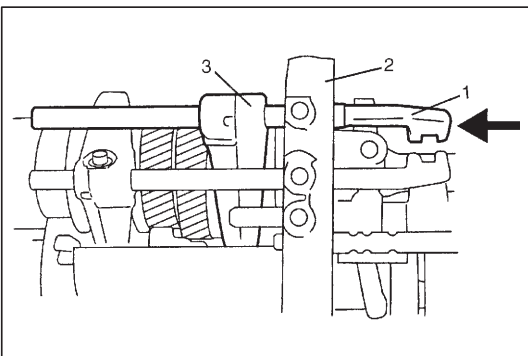

37) Insert low gear shift shaft (1) into intermediate case (2) and low speed gear shift fork (3).

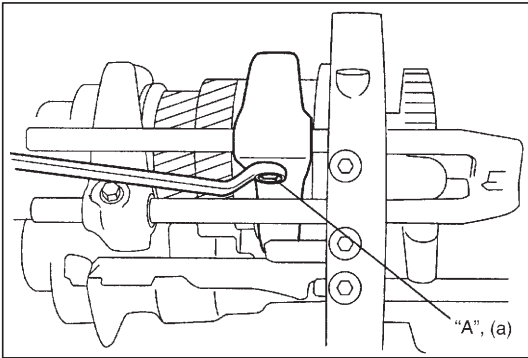

38) Apply thread lock cement to thred of fork bolt and tighten bolt to specification.

"A": Cement 99000-32110

Tightening torque

**Low speed gear shift fork bolt (a):
20 N·m (2.0 kg-m, 14.5 lb-ft)**

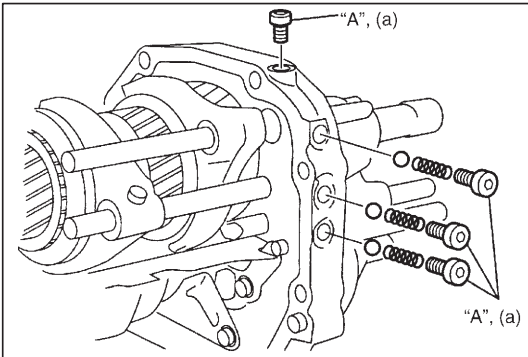

39) Install locating balls, locating springs and locating screws.

"A": Sealant 99000-31110

Tightening torque

Locating spring screws (a): 25 N·m (2.5 kg-m, 18.0 lb-ft)

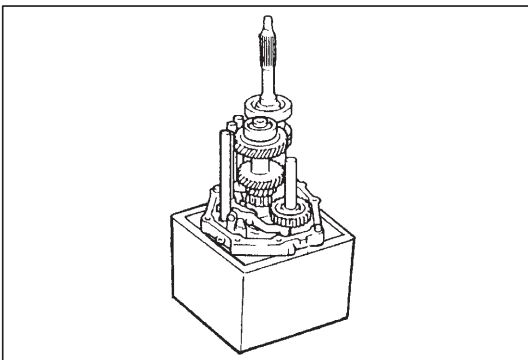

40) Place intermediate case assembly upright as shown in the figure by using workbench or the like.

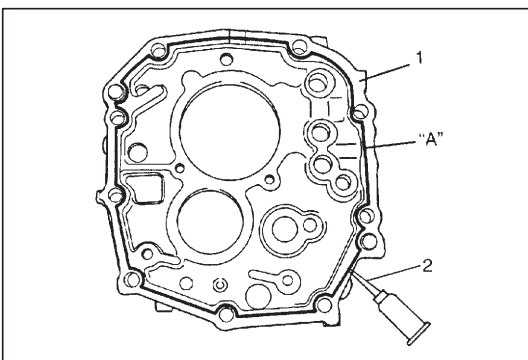

41) Apply sealant evenly to front case side of intermediate case (1) by using a nozzle (2) as shown in the figure by such amount that its section is 1.5 mm (0.059 in.) in diameter.

"A": Sealant 99000-31110

42) Clean mating surface of front case and install it to intermediate case.

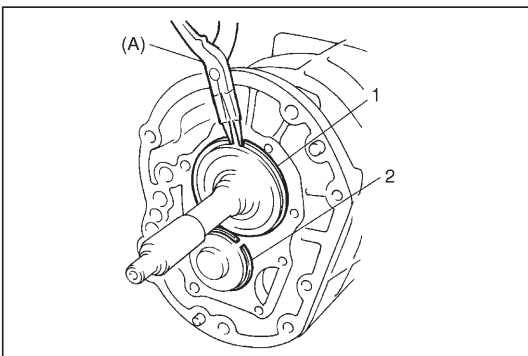

43) Fix C-rings (1, 2) to bearings as shown in the figure.

Special tool

(A): 09900-06107

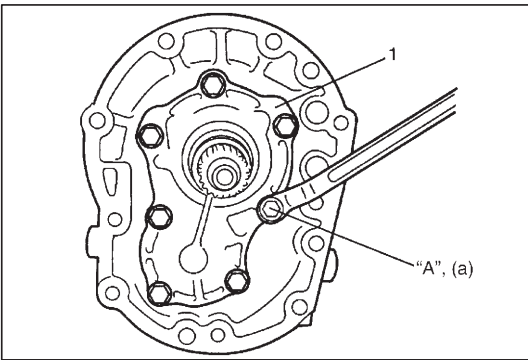

- 44) Apply sealant to input shaft bearing retainer bolt and install input shaft bearing retainer (1), new gasket and its bolts.

“A”: Sealant 99000-31110

Tightening torque

Input shaft bearing retainer bolts (a):
25 N·m (2.5 kg-m, 18.0 lb-ft)

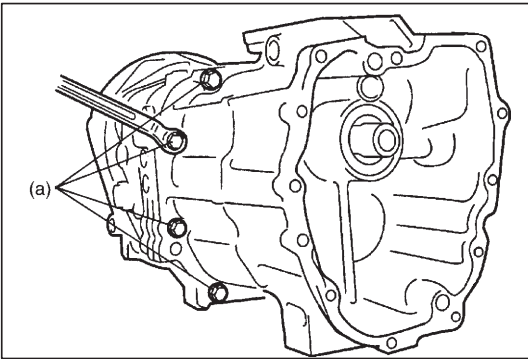

- 45) Clean mating surface of rear case and apply sealant evenly to rear case side of intermediate case in the same manner as Step 41).

Sealant: 99000-31110

- 46) Install rear case to intermediate case.

Tightening torque

Rear case to intermediate case bolts (a):
38 N·m (3.8 kg-m, 27.5 lb-ft)

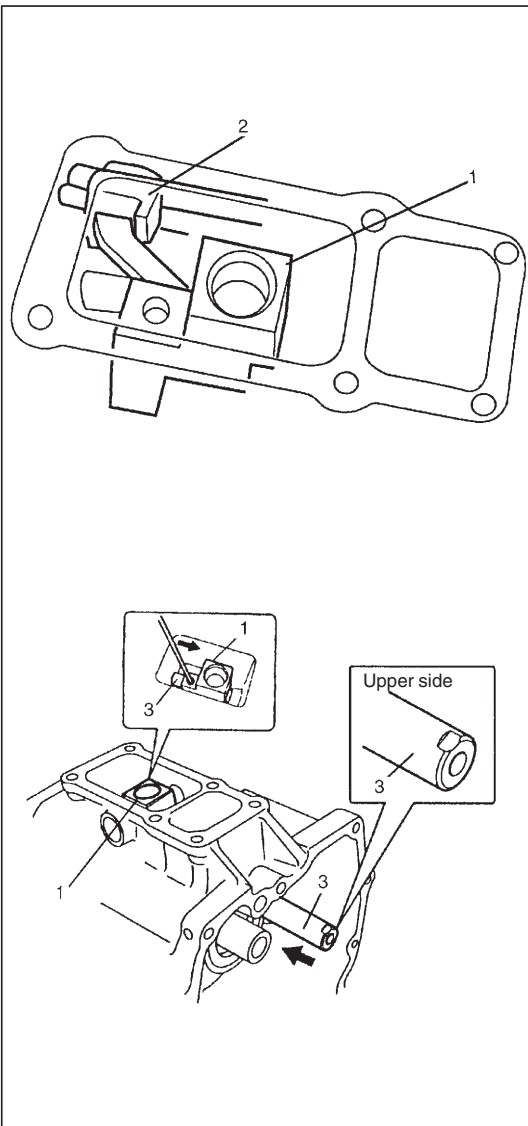

- 47) With tip end of gear shift shaft inner lever (1) hooked on head of gear shift shaft (2), insert gear shift inner shaft (3) into gear shift shaft inner lever.

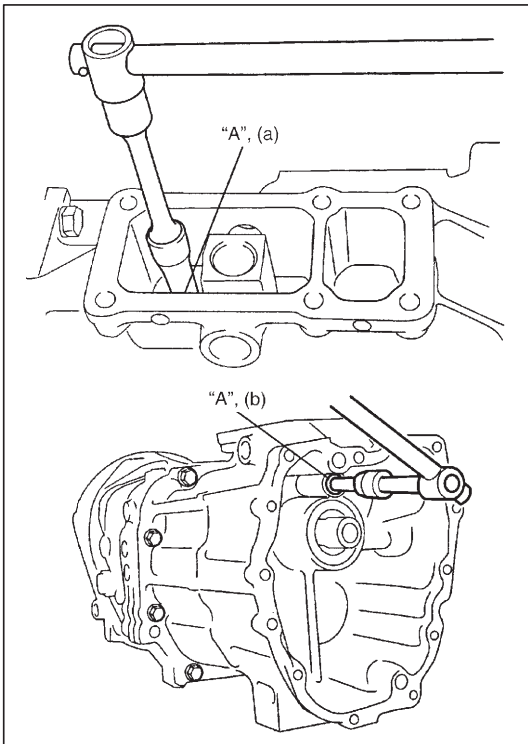

48) Apply cement “A” to inner gear shift shaft bolt and plug and tighten them to specification.

“A”: Cement: 99000-32110

Tightening torque

Gear shift shaft inner bolt (a): 40 N·m (4.0 kg-m, 29.0 lb-ft)

Gear shift shaft inner plug (b): 19 N·m (1.9 kg-m, 14.0 lb-ft)

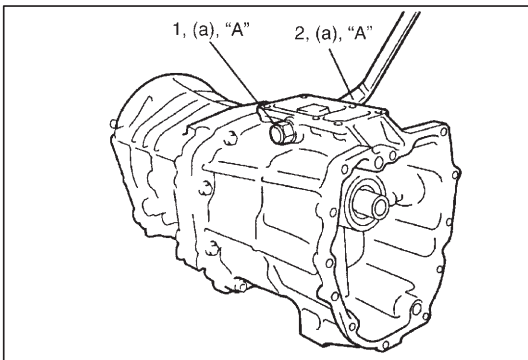

49) Tighten return spring low bolt (Yellow) (2) and return spring reverse bolt (Black) (1).

“A”: Sealant 99000-31110

Tightening torque

Return spring low bolt (Yellow) (a):

28 N·m (2.8 kg-m, 20.5 lb-ft)

Return spring reverse bolt (Black) (a):

28 N·m (2.8 kg-m, 20.5 lb-ft)

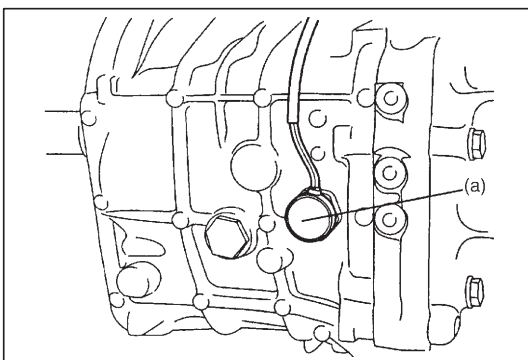

50) Install back-up light switch and new gasket.

Tightening torque

Back-up light switch (a): 45 N·m (4.5 kg-m, 32.5 lb-ft)

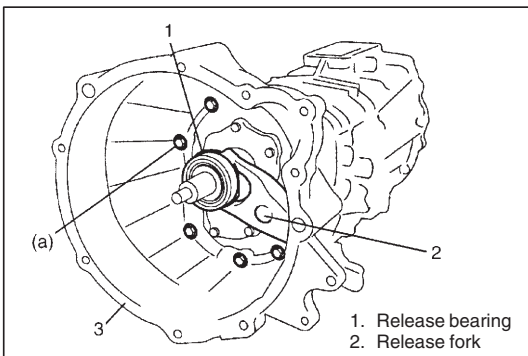

51) Install clutch housing (3) and torque its bolts to specification.

Tightening torque

Clutch housing bolt (a): 50 N·m (5.0 kg-m, 36.5 lb-ft)



TIGHTENING TORQUE SPECIFICATION

Fastening part	Tightening torque		
	N·m	kg-m	lb-ft
Transfer oil filler/level and drain plugs	23	2.3	17.0
Transmission oil filler/level and drain plugs	38	3.8	27.5
Back-up light switch	45	4.5	32.5
Control lever locating bolts	17	1.7	12.5
Gear shift lever case plate screws	6	0.6	4.5
Interlock cam plug	25	2.5	18.0
Main and counter shaft bearing plate screws	19	1.9	14.0
High and low gear shift fork bolts	20	2.0	14.5
Locating spring screws and straight plug	25	2.5	18.0
Input shaft bearing retainer bolts	25	2.5	18.0
Rear case to intermediate case bolts	38	3.8	27.5
Gear shift shaft inner bolt	40	4.0	29.0
Gear shift shaft inner plug	19	1.9	14.0
Return spring low/reverse bolts	28	2.8	20.5
Clutch housing bolts	50	5.0	36.5
Transmission to transfer bolts	23	2.3	17.0
Oil plate mounting bolts	19	1.9	14.0
Stopper mounting bolts	25	2.5	18.0
Control lever boot cover bolts	15	1.5	11.0
4WD switch	20	2.0	14.5
Transmission to engine bolts and nuts	55	5.5	40.0
Engine rear mounting member bolts	50	5.0	36.5
Exhaust No.1 pipe to manifold nuts	60	6.0	43.5
Exhaust No.1 pipe to exhaust No.2 pipe bolts	50	5.0	36.5
Exhaust No.2 pipe to muffler nuts	60	6.0	43.5
Front propeller shaft universal joint flange bolts	50	5.0	36.5
Rear propeller shaft universal joint flange bolts	60	6.0	43.5
Engine rear mounting bolts	50	5.0	36.5
CKP sensor mounting bolt	10	1.0	7.5
Stabilizer bar mount bush bracket bolts	23	2.3	17.0

REQUIRED SERVICE MATERIAL

Material	Recommended SUZUKI product (Part Number)	Use
Lithium grease	SUZUKI SUPER GREASE A (99000-25010)	<ul style="list-style-type: none"> ● Oil seal lips ● Gear shift lever bush ● Input shaft bearing roller ● Straight pin
Thread lock cement	THREAD LOCK 1322 (99000-32110)	<ul style="list-style-type: none"> ● Straight plug screw ● Gear shift shaft inner bolt ● Gear shift shaft inner plug ● Main and countershaft bearing retainer screws ● Oil plate bolts ● Stopper bolts ● Gear shift fork bolts
Sealant	SUZUKI BOND No.1215 (99000-31110)	<ul style="list-style-type: none"> ● Interlock cam plug ● Locating spring screw ● Return spring bolts ● Mating surface of gear shift lever case ● Mating surface of transmission cases ● Gear shift shaft plug ● Input shaft bearing retainer bolts

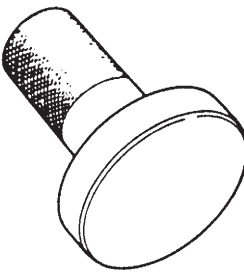
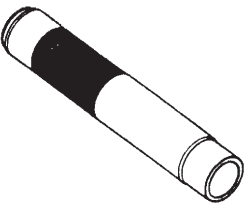
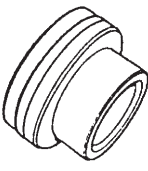
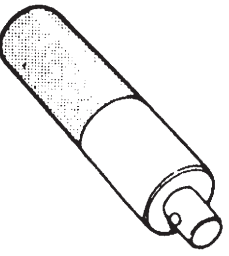
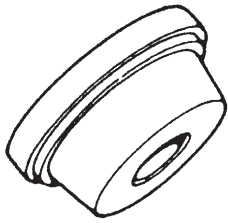
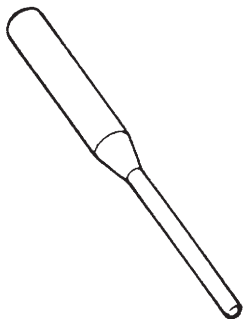
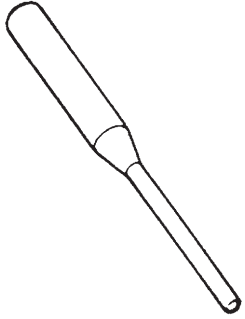
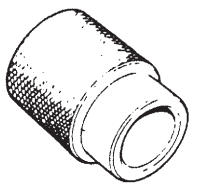
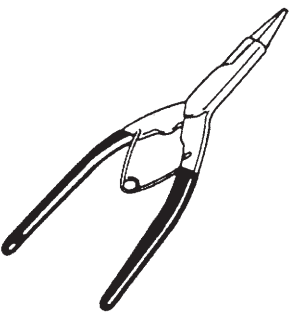
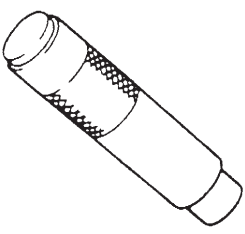
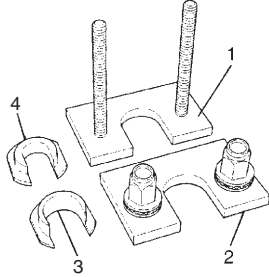
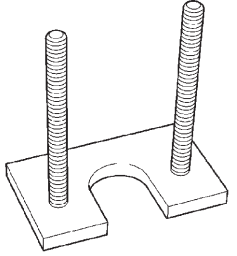
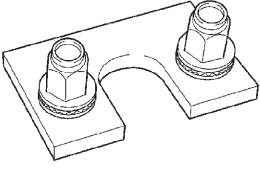
SPECIAL TOOL

 <p>09913-75520 Bearing installer</p>	 <p>09940-51710 Bearing installer</p>	 <p>09940-54950 Bearing installer attachment</p>	 <p>09913-75821 Installer attachment</p>
 <p>09924-84510-004 Bearing installer adapter (C)</p>	 <p>09925-78210 (6 mm) Spring pin remover</p>	 <p>09922-85811 (4.5 mm) Spring pin remover</p>	 <p>09940-53111 Bearing installer</p>
 <p>09900-06107 Snap ring pliers (opening type)</p>	 <p>09925-18011 Installer attachment</p>	 <p>09926-36510 Bearing remover See NOTE.</p>	 <p>09926-36510-001 Bearing remover plate No.1</p>
 <p>09926-36510-002 Bearing remover plate No.2</p>	 <p>09926-36510-003 Bearing remover attachment</p>	 <p>09926-36510-004 Bearing installer attachment</p>	

NOTE:

This special tool consists of the following tools.

1. Bearing remover plate No.1 (09926-36510-001)
2. Bearing remover plate No.2 (09926-36510-002)
3. Bearing remover attachment (09926-36510-003)
4. Bearing installer attachment (09926-36510-004)

SECTION 7B1

AUTOMATIC TRANSMISSION (4 A/T)

WARNING:

For vehicles equipped with Supplemental Restraint (Air Bag) System :

- Service on and around the air bag system components or wiring must be performed only by an authorized SUZUKI dealer. Refer to “Air Bag System Components and Wiring Location View” under “General Description” in air bag system section in order to confirm whether you are performing service on or near the air bag system components or wiring. Please observe all WARNINGS and “Service Precautions” under “On-Vehicle Service” in air bag system section before performing service on or around the air bag system components or wiring. Failure to follow WARNINGS could result in unintentional activation of the system or could render the system inoperative. Either of these two conditions may result in severe injury.
- Technical service work must be started at least 90 seconds after the ignition switch is turned to the “LOCK” position and the negative cable is disconnected from the battery. Otherwise, the system may be activated by reserve energy in the Sensing and Diagnostic Module (SDM).

CONTENTS

GENERAL DESCRIPTION	7B1- 3	TROUBLE DIAGNOSIS TABLE 3	7B1-24
CLUTCH/BRAKE FUNCTIONS	7B1- 5	ROAD TEST	7B1-25
TABLE OF COMPONENT		MANUAL ROAD TEST	7B1-26
OPERATION	7B1- 6	ENGINE BRAKE TEST	7B1-27
ELECTRONIC SHIFT CONTROL		STALL TEST	7B1-27
SYSTEM	7B1- 7	TIME LAG TEST	7B1-29
CHANGE MECHANISM	7B1- 9	LINE PRESSURE TEST	7B1-30
OPERATION OF SHIFT SOLENOIDS		P RANGE TEST	7B1-31
AND TCC SOLENOID	7B1- 9	TABLE A-1: NO GEAR SHIFT TO	
AUTOMATIC GEAR SHIFT DIAGRAM	7B1-10	O/D	7B1-32
DIAGNOSIS	7B1-11	TABLE A-2: NO LOCK-UP OCCURS ...	7B1-33
ON-BOARD DIAGNOSTIC SYSTEM	7B1-11	TABLE B-1: “O/D OFF” LAMP	
PRECAUTION IN DIAGNOSING		CIRCUIT CHECK (“O/D OFF” LAMP	
TROUBLE	7B1-12	DOESN'T LIGHT AT IGNITION SWITCH	
AUTOMATIC TRANSMISSION		ON)	7B1-34
DIAGNOSTIC FLOW TABLE	7B1-13	TABLE B-2: “O/D OFF” LAMP	
“O/D OFF” LAMP CHECK	7B1-16	CIRCUIT CHECK (“O/D OFF” LAMP	
DIAGNOSTIC TROUBLE CODE (DTC)		COMES ON STEADILY)	7B1-35
CHECK	7B1-16	INSPECTION OF TCM AND ITS	
DIAGNOSTIC TROUBLE CODE		CIRCUITS	7B1-36
CLEARANCE	7B1-18	WIRE HARNESS AND	
DIAGNOSTIC TROUBLE CODE		CONNECTORS	7B1-36
TABLE	7B1-19	DTC P0705 – TRANSMISSION	
FAIL SAFE TABLE	7B1-20	RANGE SENSOR (SWITCH) CIRCUIT	
VISUAL INSPECTION	7B1-21	MALFUNCTION	7B1-37
A/T BASIC CHECK	7B1-21	DTC P0710 TRANSMISSION FLUID	
TROUBLE DIAGNOSIS TABLE 1	7B1-22	TEMPERATURE SENSOR CIRCUIT	
TROUBLE DIAGNOSIS TABLE 2	7B1-23	MALFUNCTION	7B1-40

DTC P0715 INPUT/TURBINE SPEED SENSOR CIRCUIT MALFUNCTION	7B1- 42	SOLENOID VALVES (SHIFT SOLENOID VALVES AND TCC SOLENOID VALVE)	7B1- 67
DTC P0720 OUTPUT SPEED SENSOR CIRCUIT MALFUNCTION ..	7B1- 45	PRESSURE CONTROL SOLENOID	7B1- 68
DTC P0725 ENGINE SPEED INPUT CIRCUIT MALFUNCTION	7B1- 48	ACCELERATION STROKE SENSOR	7B1- 70
DTC P0743 TCC (LOCK-UP) SYSTEM ELECTRICAL	7B1- 50	TRANSMISSION CONTROL MODULE (TCM)	7B1- 70
DTC P0748 PRESSURE CONTROL SOLENOID ELECTRICAL	7B1- 52	4WD LOW SWITCH	7B1- 71
DTC P0753/P0758 SHIFT SOLENOID-A/SHIFT SOLENOID-B ELECTRICAL	7B1- 54	OIL COOLER PIPES	7B1- 71
DTC P1700 ACCELERATION STROKE POSITION SIGNAL INPUT MALFUNCTION	7B1- 56	AUTOMATIC TRANSMISSION ASSEMBLY (WITH TRANSFER)	7B1- 72
DTC P1702 INTERNAL MALFUNCTION OF TCM	7B1- 58	UNIT REPAIR	7B1- 77
DTC P1730 ENGINE TORQUE SIGNAL CIRCUIT MALFUNCTION ...	7B1- 59	PRECAUTIONS	7B1- 77
ON-VEHICLE SERVICE	7B1- 61	PART INSPECTION AND CORRECTION TABLE	7B1- 78
MAINTENANCE SERVICE	7B1- 61	UNIT DISASSEMBLY	7B1- 79
FLUID LEVEL	7B1- 61	SUB-ASSEMBLY REPAIR	7B1- 84
FLUID CHANGE	7B1- 62	OVERDRIVE (CASE SIDE)	7B1- 84
OIL COOLER HOSES	7B1- 63	FORWARD CLUTCH	7B1- 87
MANUAL SELECTOR ASSEMBLY	7B1- 63	DIRECT CLUTCH	7B1- 91
SELECT CABLE	7B1- 64	CENTER SUPPORT	7B1- 94
TRANSMISSION RANGE SWITCH	7B1- 65	PLANETARY GEARS AND OUTPUT SHAFT	7B1-100
INPUT SHAFT SPEED SENSOR	7B1- 66	VALVE BODY ASSEMBLY	7B1-104
OUTPUT SHAFT SPEED SENSOR	7B1- 66	UNIT ASSEMBLY	7B1-106
O/D OFF SWITCH	7B1- 66	BEARING AND RACE INSTALLATION DIAGRAM	7B1-116
SOLENOID VALVES (SHIFT SOLENOID VALVES, TCC SOLENOID VALVE AND PRESSURE CONTROL SOLENOID VALVE)	7B1- 67	TIGHTENING TORQUE SPECIFICATION	7B1-117
		REQUIRED SERVICE MATERIAL	7B1-118
		SPECIAL TOOL	7B1-118

GENERAL DESCRIPTION

This automatic transmission is a full automatic type with 3-speed plus overdrive (O/D).

The torque converter is a 3-element, 1-step and 2-phase type and is equipped with an electronically controlled lock-up mechanism. The gear shift device consists of 3 sets of planetary gear units, 3 disc type clutches, 4 disc type brakes and 3 one-way clutches. The gear shift is done by selecting one of 6 positions ("P", "R", "N", "D", "2" and "L") of the select lever installed on the floor. On the shift knob, there is an overdrive (O/D) off switch which prevents shift-up to the overdrive mode. The optimum line pressure of fluid is obtained based on throttle pressure of fluid. The throttle pressure of fluid which corresponds to engine load (engine torque) is adjusted by electronic controlled linear solenoid.

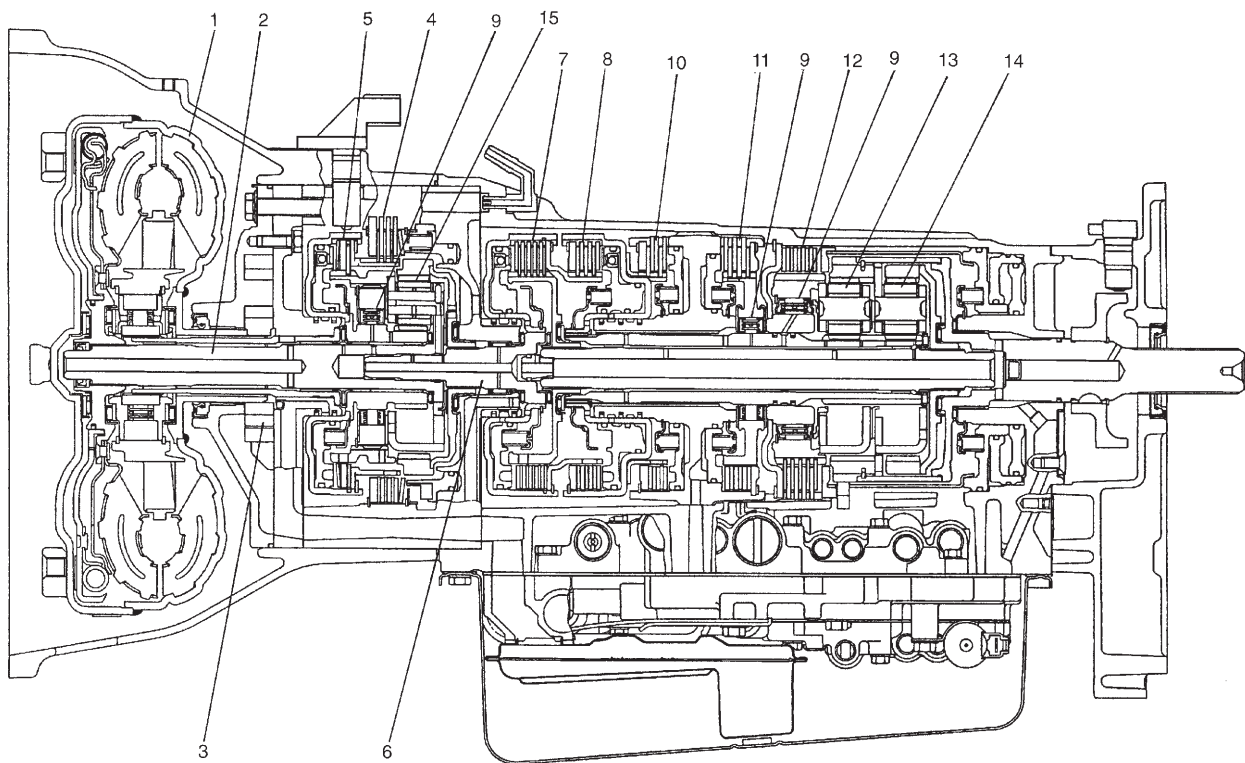

- | | |
|-------------------------------|------------------------------|
| 1. Torque converter | 9. One-way clutch |
| 2. Overdrive input shaft | 10. Second coast brake |
| 3. Oil pump | 11. Second brake |
| 4. Overdrive brake | 12. Reverse brake |
| 5. Overdrive clutch | 13. Front planetary gear |
| 6. Forward clutch input shaft | 14. Rear planetary gear |
| 7. Forward clutch | 15. Overdrive planetary gear |
| 8. Direct clutch | |

Item		Specifications	
Torque converter	Type	3-element, 1-step, 2-phase type (with TCC (lock-up) mechanism)	
	Stall torque ratio	1.9	
Oil pump	Type	Trochoid type oil pump	
	Drive system	Engine driven	
Gear change device	Type	Forward 4-step, reverse 1-step planetary gear type	
	Shift position	"P" range Gear in neutral, output shaft fixed, engine start "R" range Reverse "N" range Gear in neutral, engine start "D" range (O/D ON) Forward 1st ↔ 2nd ↔ 3rd ↔ 4th (O/D) automatic gear change "D" range (O/D OFF) Forward 1st ↔ 2nd ↔ 3rd automatic gear change "2" range Forward 1st ↔ 2nd ← 3rd automatic gear change "L" range Forward 1st ← 2nd ← 3rd reduction, and fixed at 1st gear	
	Gear ratio	1st (low gear)	2.452
		2nd (second gear)	1.452
		3rd (top gear)	1.000
		4th (overdrive gear)	0.689
		Reverse (reverse gear)	2.212
	Control elements	Wet type multi-disc clutch 3 sets Wet type multi-disc brake 4 sets One-way clutch 3 sets	
	Transfer	Hi : 1.000 Lo : 1.816 (4WD model only)	
	Final gear reduction ratio (Differential)	4.300	
	Lubrication	Lubrication system	Force feed system by oil pump
Cooling	Cooling system	Radiator assisted cooling (water-cooled)	
Fluid used		An equivalent of DEXRON®III	

CLUTCH/BRAKE FUNCTIONS

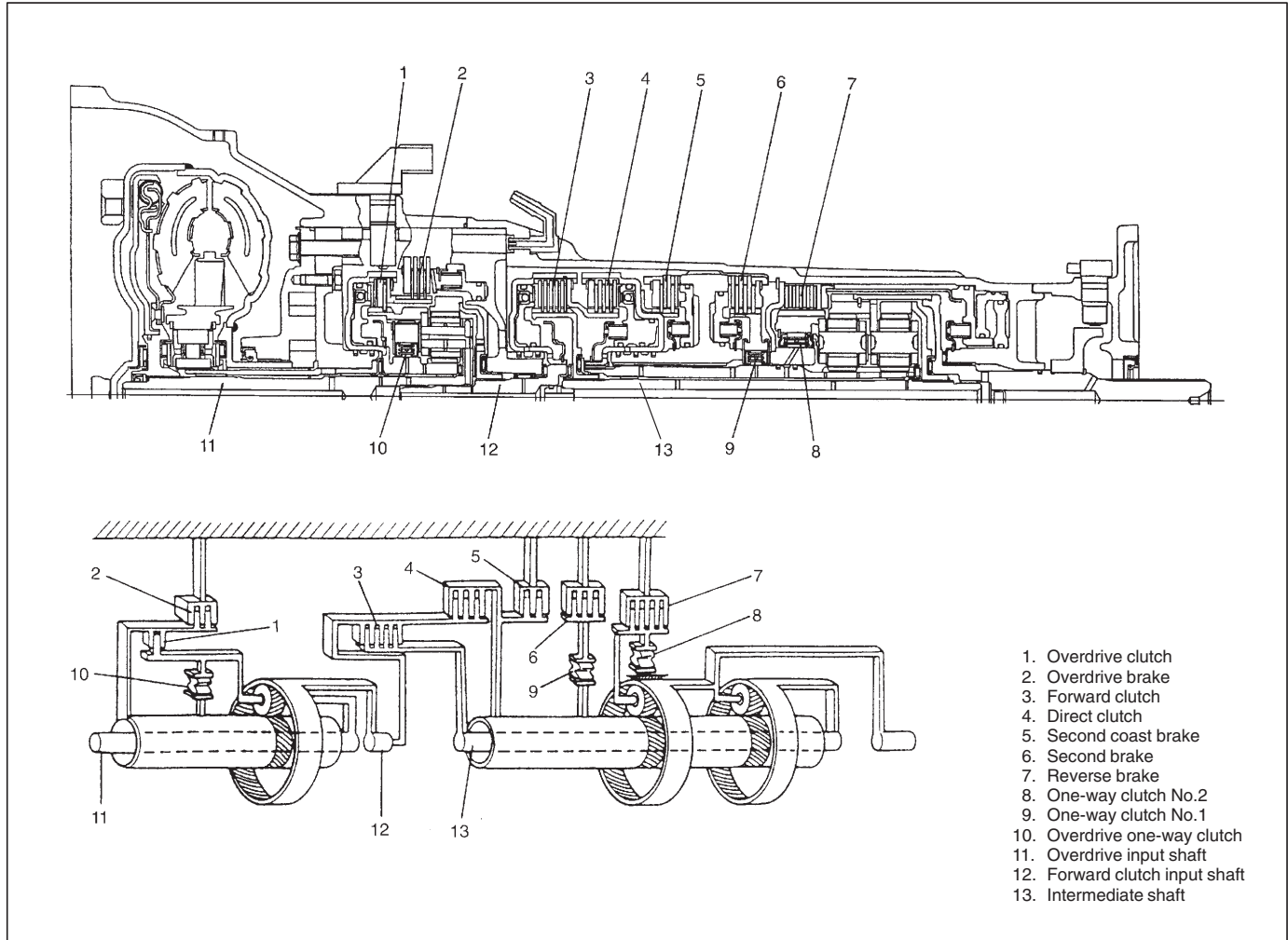

Part Name	Function
Overdrive clutch	Meshes overdrive carrier incorporated with overdrive input shaft and overdrive sun gear.
Overdrive brake	Fixes overdrive sun gear.
Overdrive one-way clutch	Meshes overdrive carrier and overdrive sun gear only when driven by engine.
Forward clutch	Meshes forward clutch input shaft and intermediate shaft.
Direct clutch	Meshes forward clutch input shaft with front sun gear and rear sun gear.
Second coast brake	Fixes front sun gear and rear sun gear.
Second brake	Fixes outer race of one-way clutch No.1, to prevent front sun gear and rear sun gear from turning counterclockwise (reverse direction of engine input rotation direction).
Reverse brake	Fixes front planetary carrier.
One-way clutch No.1	Prevents front sun gear and rear sun gear from turning counterclockwise only when second brake is at work.
One-way clutch No.2	Prevents front planetary carrier from turning counterclockwise.

TABLE OF COMPONENT OPERATION

Shift position	Element	Solenoid valve-A (No.1)	Solenoid valve-B (No.1)	O/D clutch	Forward clutch	Direct clutch	O/D brake	Second coast brake	Second brake	Reverse brake		O/D one-way clutch	One-way clutch No.1	One-way clutch No.2
										Inner piston	Outer piston			
P		○	X	○	-	-	-	-	-	-	-	○	-	-
R		○	X	○	-	○	-	-	-	○	○	○	-	-
N		○	X	○	-	-	-	-	-	-	-	○	-	-
D	1st gear	○	X	○	○	-	-	-	-	-	-	○	-	○
	2nd gear	○	○	○	○	-	-	-	○	-	-	○	○	-
	3rd gear	X	○	○	○	○	-	-	○	-	-	○	-	-
	O/D	X	X	-	○	○	○	-	○	-	-	-	-	-
2	1st gear	○	X	○	○	-	-	-	-	-	-	○	-	○
	2nd gear	○	○	○	○	-	-	○	○	-	-	○	-	-
	3rd gear (Fail safe)	X	○	○	○	○	-	-	○	-	-	○	-	-
L	1st gear	○	X	○	○	-	-	-	-	○	○	○	-	-
	2nd gear (Fail safe)	○	○	○	○	-	-	○	○	-	-	○	-	-

○: ON, X: OFF

ELECTRONIC SHIFT CONTROL SYSTEM

The gear ratio change in "D" or "2" range and torque converter clutch operation are controlled by Transmission Control Module (TCM).

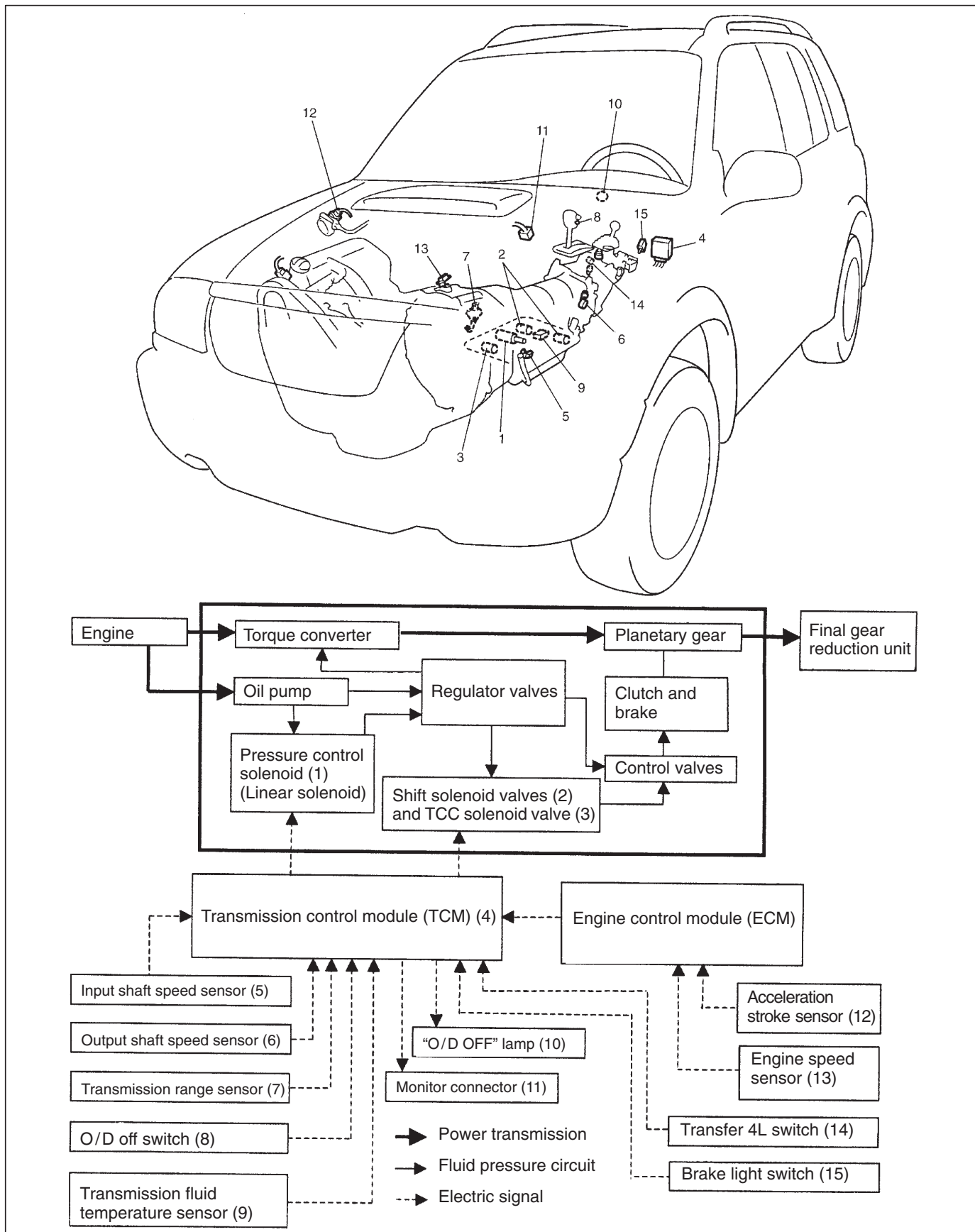

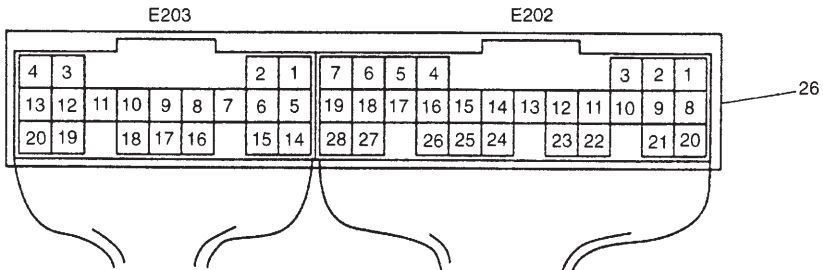
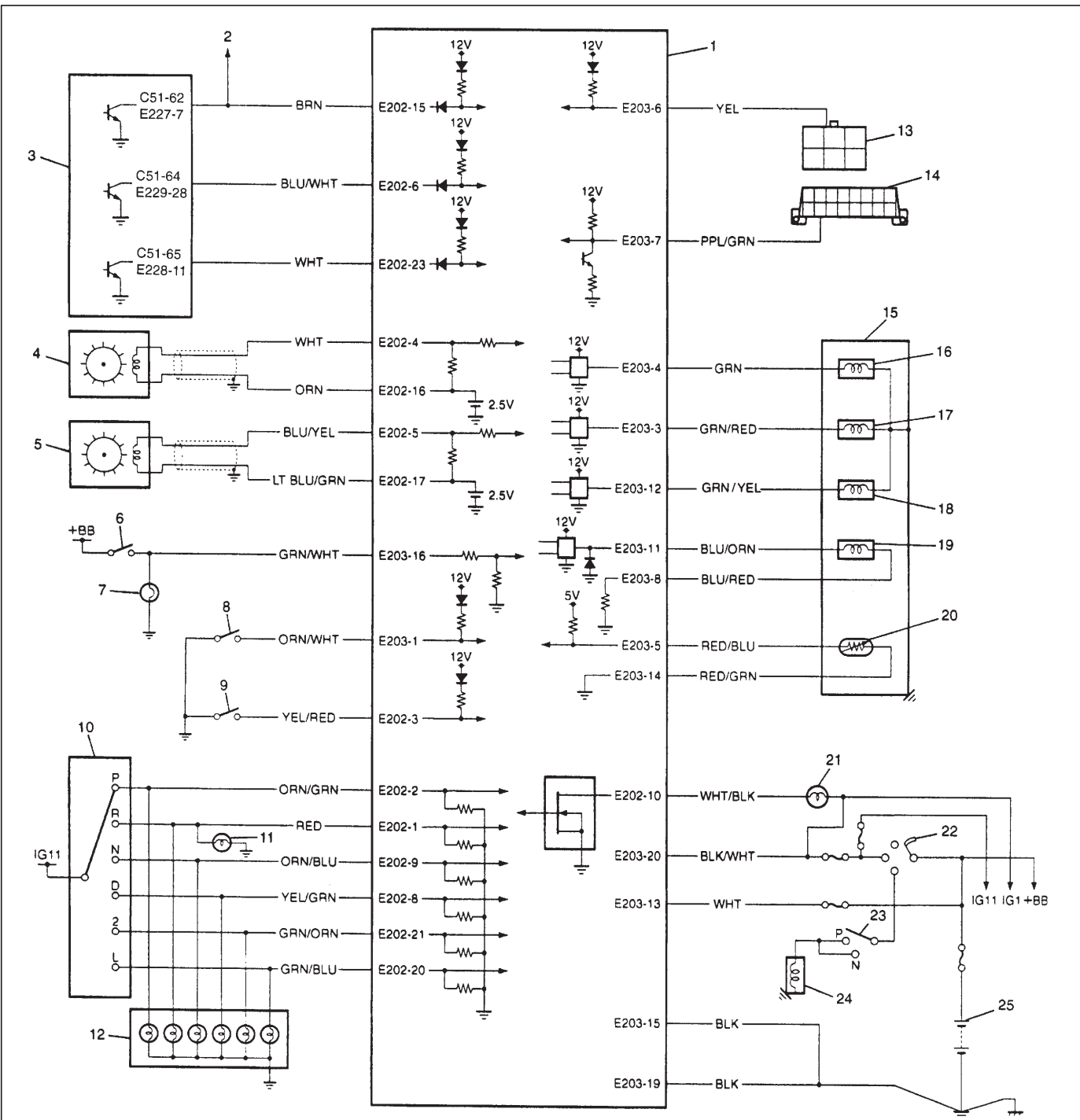

- 1. TCM
- 2. To tachometer
- 3. ECM
- 4. Output shaft speed sensor
- 5. Input shaft speed sensor
- 6. Brake light switch
- 7. Brake light
- 8. 4WD low switch
- 9. O/D off switch
- 10. Transmission range sensor
- 11. Backup lamp
- 12. Shift indicator
- 13. Monitor connector
- 14. Data link connector (DLC)
- 15. A/T
- 16. Shift solenoid-A (Shift solenoid No.1)
- 17. Shift solenoid-B (Shift solenoid No.2)
- 18. TCC (Lock-up) solenoid
- 19. Pressure control solenoid
- 20. Transmission fluid temp. sensor
- 21. "O/D OFF" lamp
- 22. Ignition switch
- 23. Inhibitor switch (In transmission range sensor)
- 24. Starter relay
- 25. Battery
- 26. Terminal arrangement of TCM coupler (Viewed from harness side)

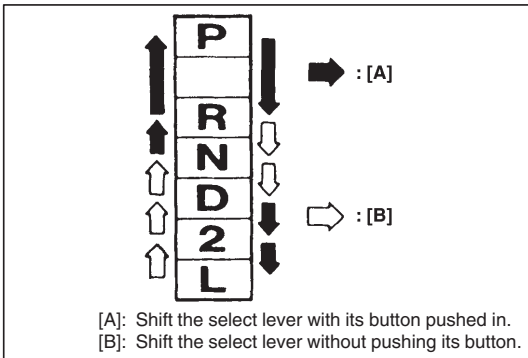

CHANGE MECHANISM

The same select pattern shift lever is used as the floor type and frequently used “N” and “D” ranges are made selectable freely.

OPERATION OF SHIFT SOLENOIDS AND TCC SOLENOID

RANGE		D				2		L	P, N & R
GEAR		1st	2nd	3rd	4th (O/D)	1st	2nd	1st	–
SOLENOIDS	Shift solenoid-A (NO.1)	○	○	X	X	○	○	○	○
	Shift solenoid-B (NO.2)	X	○	○	X	X	○	X	X
	TCC solenoid	X	X	○	○	X	X	X	X

○: ON (Turn power on)

X: OFF (Turn power off)

	Valve status	
	Turn power ON	Turn power OFF
Shift solenoid-A (NO.1)	Close	Open
Shift solenoid-B (NO.2)	Close	Open
TCC solenoid	Open	Close

AUTOMATIC GEAR SHIFT DIAGRAM

Automatic shift schedule as a result of shift control is shown below. In case that select lever is shifted to L at a higher than 40 km/h or 25 mile/h speed, 2nd or 3rd gear is operated and then down shifts to 1st at a speed lower than that. No up shift is available in L.

The same as, the select lever is shifted to 2 at a higher than 82 km/h (51 mile/h) speed, 3rd gear is operated and then down shifts to 2nd at a speed lower than that.

		Shift					
		1 → 2	2 → 3	3 → 4	4 → 3	3 → 2	2 → 1
Throttle opening	Full throttle km/h (mile/h)	40 (25)	73 (46)	110 (69)	102 (64)	65 (41)	31 (19)
	Closed throttle km/h (mile/h)	15 (9)	25 (16)	38 (24)	34 (21)	22 (14)	8 (5)

GEAR SHIFT DIAGRAM [A] AND TCC LOCK-UP DIAGRAM [B]

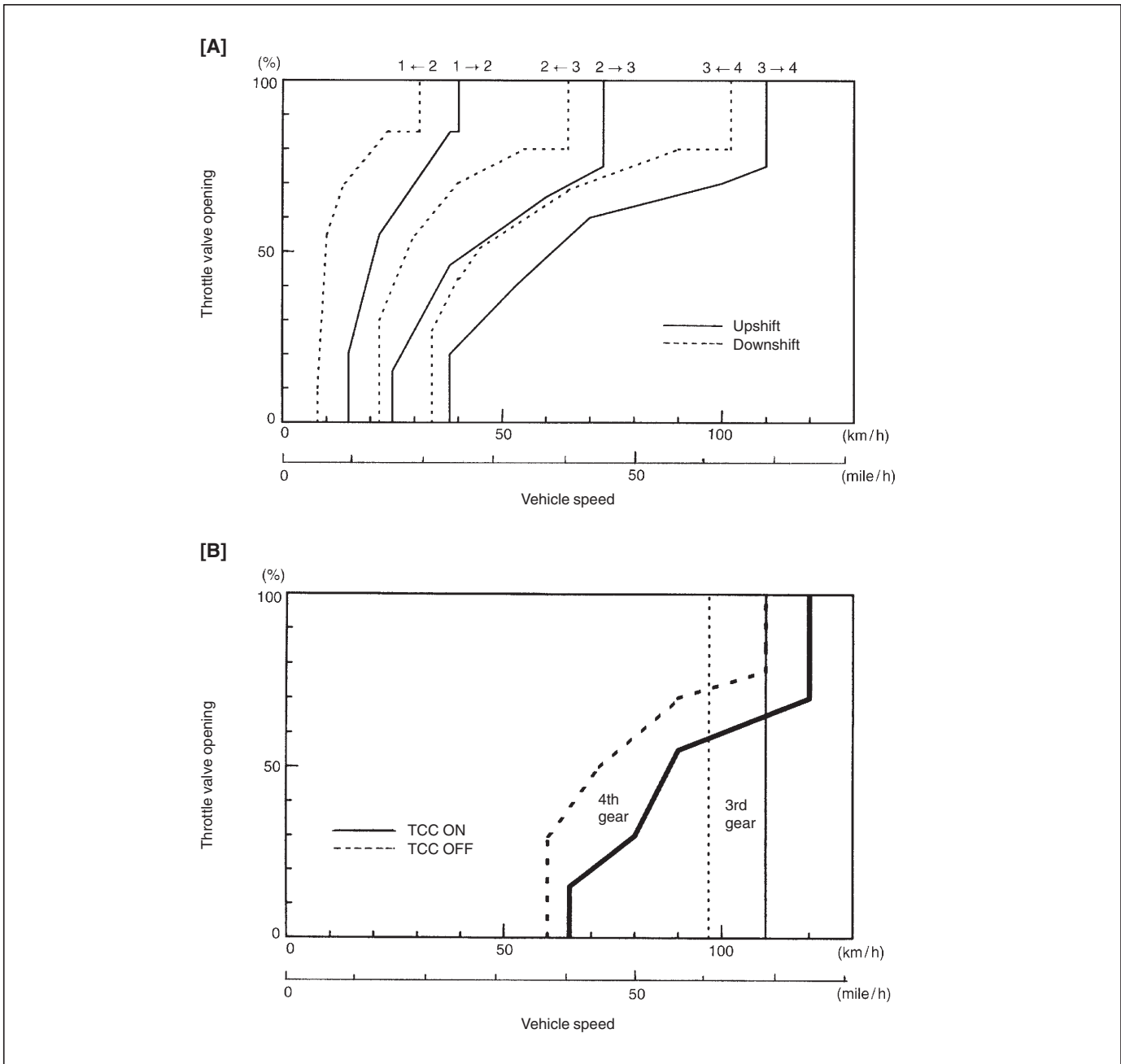

DIAGNOSIS

This vehicle is equipped with an electronic transmission control system, which control the automatic shift up and shift down timing, TCC operation, etc. suitably to vehicle driving conditions.

TCM has an On-Board Diagnostic system which detects a malfunction in this system and abnormality of those parts. When diagnosing a trouble in the transmission including this system, be sure to have full understanding of the outline of "ON-BOARD DIAGNOSTIC SYSTEM" and each item in "PRECAUTION IN DIAGNOSING TROUBLE" and execute diagnosis according to "AUTOMATIC TRANSMISSION DIAGNOSTIC FLOW TABLE" to obtain correct result smoothly.

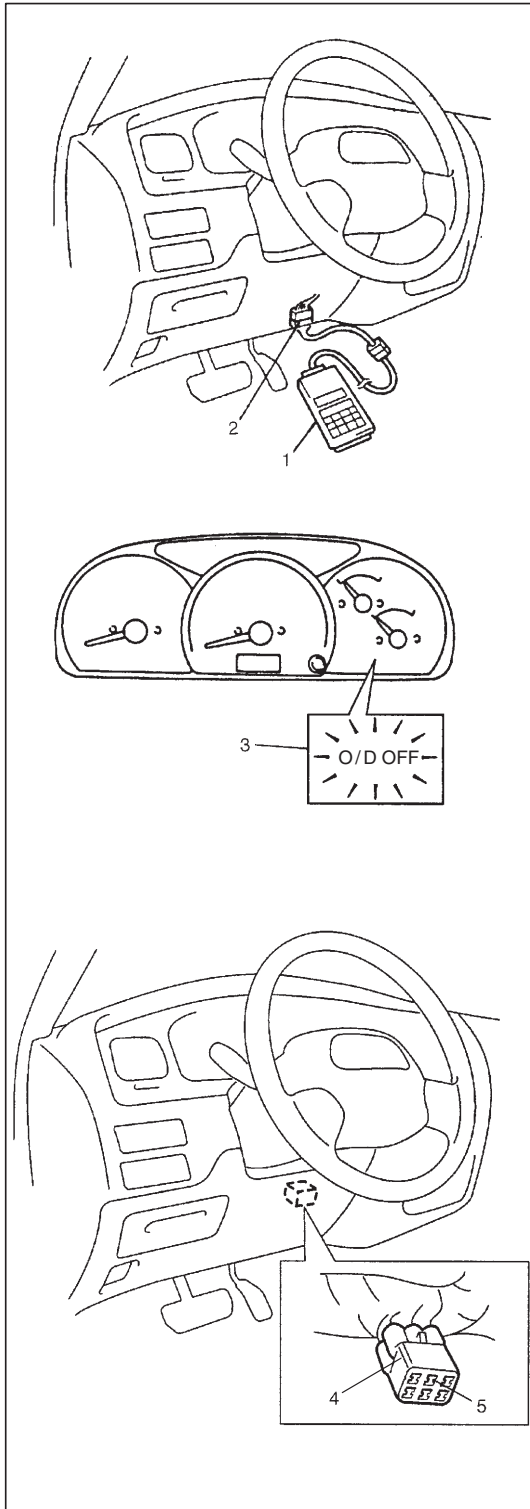

ON-BOARD DIAGNOSTIC SYSTEM

For automatic transmission control system, TCM has following functions.

- When TCM detects a malfunction in A/T control system while the engine is running, it stores the malfunction area in its memory.
- It is possible to communicate through DLC (2) by using SUZUKI scan tool (1). (Diagnostic information can be accessed by using a scan tool (1).)
- It is also possible to output by flashing of "O/D OFF" lamp (3) with diagnosis switch terminal (5) of monitor connector (4) grounded. If no DTC is stored in TCM memory, DTC No.12 is outputted repeatedly.

If one or more DTCs are stored in TCM memory, they are outputted three times per one code starting from smallest code number in increasing order.

After all DTCs are outputted, all DTCs are outputted again in the manner mentioned above.

PRECAUTION IN DIAGNOSING TROUBLE

- Don't disconnect couplers from TCM, battery cable from battery, TCM ground wire harness from engine or main fuse before checking DTC stored in TCM memory. Such disconnection will clear memorized information in TCM memory.
- Using SUZUKI scan tool, the diagnostic information stored in TCM memory can be checked and cleared as well. Before its use, be sure to read Operator's (Instruction) Manual supplied with it carefully to have good understanding of its functions and usage.
- Be sure to read "PRECAUTIONS FOR ELECTRICAL CIRCUIT SERVICE" in Section 0A before inspection and observe what is written there.
- TCM replacement
When substituting a known-good TCM, check for following conditions.
Neglecting this check may result in damage to a good TCM.
– All relays and actuators have resistance of specified value.

AUTOMATIC TRANSMISSION DIAGNOSTIC FLOW TABLE

Refer to the following pages for the details of each step.

Step	Action	Yes	No
1	Customer Complaint Analysis 1) Perform customer complaint analysis referring to the next page. Was customer complaint analysis performed according to instruction?	Go to Step 2.	Perform customer complaint analysis.
2	Diagnostic Trouble Code (DTC) Check, Record and Clearance 1) Check for DTC Is there any DTC(s)?	Print DTC or write them down and clear them by referring to "DTC CLEARANCE" in this section. Go to Step 3.	Go to Step 4.
3	Visual Inspection 1) Perform visual inspection referring to the next page. Is there any faulty condition?	Repair or replace malfunction part. Go to Step 11.	Go to Step 5.
4	Visual Inspection 1) Perform visual inspection referring to the next page. Is there any faulty condition?		Go to Step 8.
5	Trouble Symptom Confirmation 1) Confirm trouble symptom referring to the next page. Is trouble symptom identified?	Go to Step 6.	Go to Step 7.
6	Rechecking and Record of DTC 1) Recheck for DTC referring to "DTC CHECK" in this section. Is there any DTC(s)?	Go to Step 9.	Go to Step 8.
7	Rechecking and Record of DTC 1) Recheck for DTC referring to "DTC CHECK" in this section. Is there any DTC(s)?	Go to Step 9.	Go to Step 10.
8	Automatic Transmission Basic Inspection and Trouble Diagnosis Table 1) Check and repair according to "A/T BASIC CHECK" and "TROUBLE DIAGNOSIS TABLE" in this section. Are check and repair complete?	Go to Step 11.	Check and repair malfunction part(s). Go to Step 11.
9	Troubleshooting for DTC 1) Check and repair according to applicable DTC diag. flow Table. Are check and repair complete?		
10	Check for Intermittent Problems 1) Check for intermittent problems referring to the next page. Is there any faulty condition?	Repair or replace malfunction part(s). Go to Step 11.	Go to Step 11.

Step	Action	Yes	No
11	Final Confirmation Test 1) Clear DTC if any. 2) Perform final confirmation test referring to the next page. Is there any problem symptom, DTC or abnormal condition?	Go to Step 6.	End.

STEP 1. CUSTOMER COMPLAINT ANALYSIS

Record details of the problem (failure, complaint) and how it occurred as described by the customer.

For this purpose, use of such a inspection form will facilitate collecting information to the point required for proper analysis and diagnosis.

STEP 2. DIAGNOSTIC TROUBLE CODE (DTC) CHECK, RECORD AND CLEARANCE

First, referring to "DTC CHECK" in this section, check DTC. If DTC exists, print or write down DTC and then clear them by referring to "DTC CLEARANCE" in this section. DTC indicates malfunction in the system but it is not possible to know from it whether the malfunction is occurring now or it occurred in the past and normal condition has been restored. In order to know that, check symptom in question according to Step 5 and then recheck DTC according to Step 6.

Diagnosing a trouble based on the DTC in this step only or failure to clear the DTC in this step may result in a faulty diagnosis, trouble diagnosis of a normal circuit or difficulty in troubleshooting which is otherwise unnecessary.

STEP 3 and STEP 4. VISUAL INSPECTION

As a preliminary step, be sure to perform visual check of the items that support proper function of the A/T and engine referring to "VISUAL INSPECTION" in this section.

STEP 5. TROUBLE SYMPTOM CONFIRMATION

Check trouble symptoms based on information obtained in Step 1 "CUSTOMER COMPLAINT ANALYSIS" and Step 2 "DTC CHECK".

Also, recheck DTC according to "DTC CONFIRMATION PROCEDURE" described in each "DTC FLOW TABLE".

STEP 6 and STEP 7. RECHECKING AND RECORD OF DTC

Refer to "DTC CHECK" in this section for checking procedure.

STEP 8. A/T BASIC CHECK AND TROUBLE DIAGNOSIS TABLE

Perform A/T basic check according to the "A/T BASIC CHECK FLOW TABLE" first. When the end of the flow table has been reached, check the parts of the system suspected as a possible cause referring to "TROUBLE DIAGNOSIS TABLE" and based on symptoms appearing on the vehicle (symptoms obtained through steps of customer complaint analysis, trouble symptom confirmation and/or A/T basic check) and repair or replace faulty parts, if any.

STEP 9. DIAGNOSTIC TROUBLE CODE FLOW TABLE

Based on the DTC indicated in Step 6 and 7 and referring to "DIAGNOSTIC TROUBLE CODE FLOW TABLE" in this section, locate the cause of the trouble, namely in a sensor, switch, wire harness, connector, actuator, TCM or other part and repair or replace faulty parts.

STEP 10. CHECK FOR INTERMITTENT PROBLEM

Check parts where an intermittent trouble is easy to occur (e.g., wire harness, connector, etc.), referring to “INTERMITTENT AND POOR CONNECTION” in Section 0A and related circuit of DTC recorded in Step 2.

STEP 11. FINAL CONFIRMATION TEST

Confirm that the problem symptom has gone and the A/T is free from any abnormal conditions.

If what has been repaired is related to the malfunction DTC, clear the DTC once, set conditions under which DTC was detected and A/T and/or vehicle was repaired and confirm that no DTC is indicated.

CUSTOMER PROBLEM INSPECTION FORM (EXAMPLE)

User name:	Model:	VIN:	
Date of issue:	Date of Reg:	Date of problem:	Mileage:
PROBLEM SYMPTOMS			
<input type="checkbox"/> Engine does not start <input type="checkbox"/> Vehicle does not move (forward, rearward) <input type="checkbox"/> No lock-up (TCC clutch operation) <input type="checkbox"/> Shift point too high or too low <input type="checkbox"/> Excessive gear change shock		<input type="checkbox"/> Engine stops <input type="checkbox"/> Transmission does not shift (1st, 2nd, 3rd, 4th, Rev) gear <input type="checkbox"/> Automatic shift does not occur <input type="checkbox"/> Transmission slipping in (1st, 2nd, 3rd, 4th, Rev) gear <input type="checkbox"/> Other:	
VEHICLE/ENVIRONMENTAL CONDITION WHEN PROBLEM OCCURS			
Environmental Condition			
Weather	<input type="checkbox"/> Fair/ <input type="checkbox"/> Cloudy/ <input type="checkbox"/> Rain/ <input type="checkbox"/> Snow/ <input type="checkbox"/> Always/ <input type="checkbox"/> Other ()		
Temperature	<input type="checkbox"/> Hot/ <input type="checkbox"/> Warm/ <input type="checkbox"/> Cool/ <input type="checkbox"/> Cold/ <input type="checkbox"/> (°C °F)/ <input type="checkbox"/> Always		
Frequency	<input type="checkbox"/> Always/ <input type="checkbox"/> Sometimes/ <input type="checkbox"/> (times/ day, month)/ <input type="checkbox"/> Only Once		
Road	<input type="checkbox"/> Urban/ <input type="checkbox"/> Suburb/ <input type="checkbox"/> Highway/ <input type="checkbox"/> Mountainous (uphill/downhill)/ <input type="checkbox"/> Paved road/ <input type="checkbox"/> Gravel/ <input type="checkbox"/> Other ()		
Vehicle Condition			
Transmission range	<input type="checkbox"/> (P, R, N, D, 2, L) range/ <input type="checkbox"/> (→) range		
Transmission temp.	<input type="checkbox"/> Cold/ <input type="checkbox"/> Warming up phase/ <input type="checkbox"/> Warmed up		
Vehicle	<input type="checkbox"/> At stop/ <input type="checkbox"/> During driving (constant speed/accelerating/decelerating/ right hand corner/left hand corner)/ <input type="checkbox"/> Other ()/ <input type="checkbox"/> Speed (km/h mile/h)		
Engine	<input type="checkbox"/> Speed (r/min)/ <input type="checkbox"/> Throttle opening (idle/about %/full)		
Brake	<input type="checkbox"/> Apply/ <input type="checkbox"/> Not apply		
O/D off switch	<input type="checkbox"/> ON/ <input type="checkbox"/> OFF		
Diagnostic trouble code	First check : <input type="checkbox"/> No code <input type="checkbox"/> Malfunction code () Second check : <input type="checkbox"/> No code <input type="checkbox"/> Malfunction code ()		

NOTE:

The above form is a standard sample. It should be modified according to conditions characteristic of each market.

“O/D OFF” LAMP CHECK

- 1) Check that O/D off switch button is at OFF position (pushed).
- 2) Turn ignition switch ON.
- 3) Check that “O/D OFF” lamp lights for about 2 – 4 sec. and then goes OFF.

If anything faulty is found, advance “DIAGNOSTIC FLOW TABLE B-1 or B-2 “O/D OFF” LAMP CIRCUIT CHECK”.

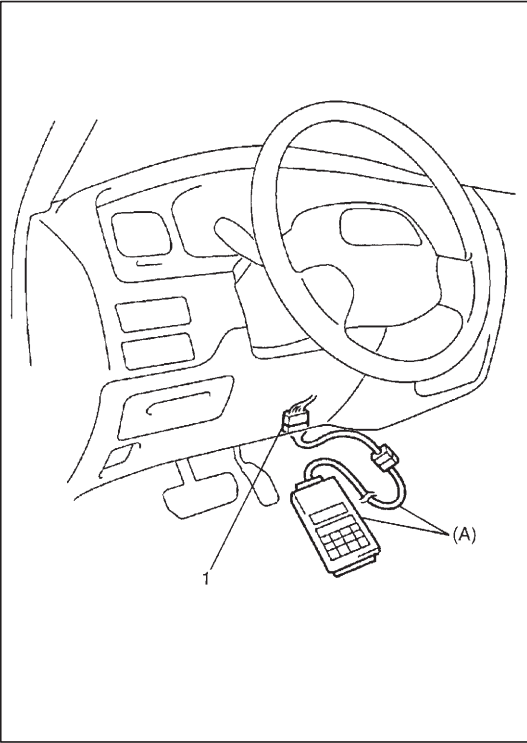

DIAGNOSTIC TROUBLE CODE (DTC) CHECK

[Check DTC using SUZUKI scan tool]

- 1) Turn ignition switch OFF.
- 2) After setting cartridge, connect SUZUKI scan tool to data link connector (DLC) (1) located in underside of instrument panel at driver's seat side.

Special tool

(A): SUZUKI scan tool

- 3) Turn ignition switch ON.
- 4) Read DTC according to instructions displayed on SUZUKI scan tool and print it down. Refer to SUZUKI scan tool operator's manual for further details.
- 5) After completing the check, turn ignition switch OFF and disconnect SUZUKI scan tool from data link connector (DLC) (1).

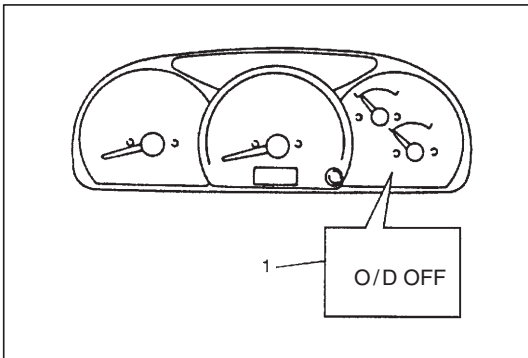

[Check DTC not using SUZUKI scan tool]

- 1) Turn ignition switch ON and make sure that "O/D OFF" lamp (1) is OFF in combination meter (with O/D off switch OFF).
- 2) Turn ignition switch OFF.

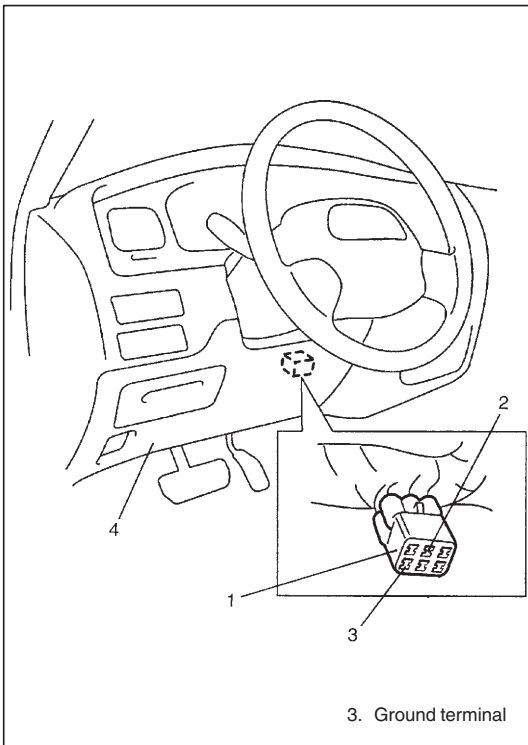

- 3) Remove steering column hole cover (4).
- 4) Using service wire, ground diagnosis switch terminal (2) of monitor connector (1).

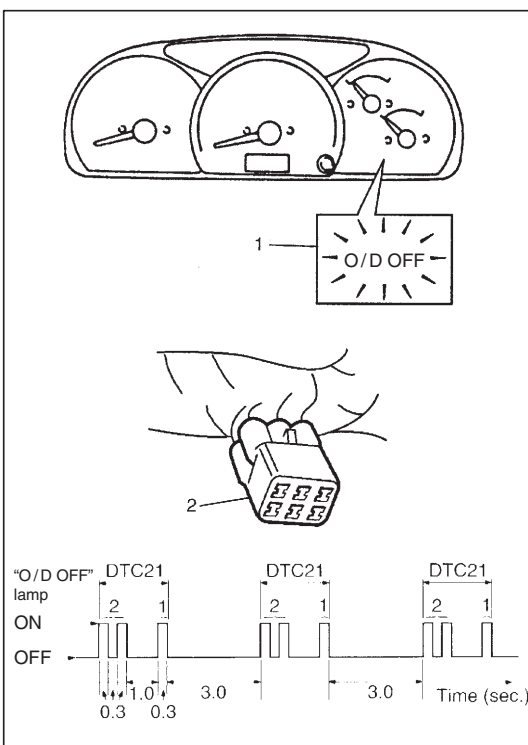

- 5) Turn ignition switch ON.
- 6) Read DTC from flashing pattern of "O/D OFF" lamp (1).
- 7) After completing the DTC check, turn ignition switch OFF and disconnect service wire from monitor connector (2).

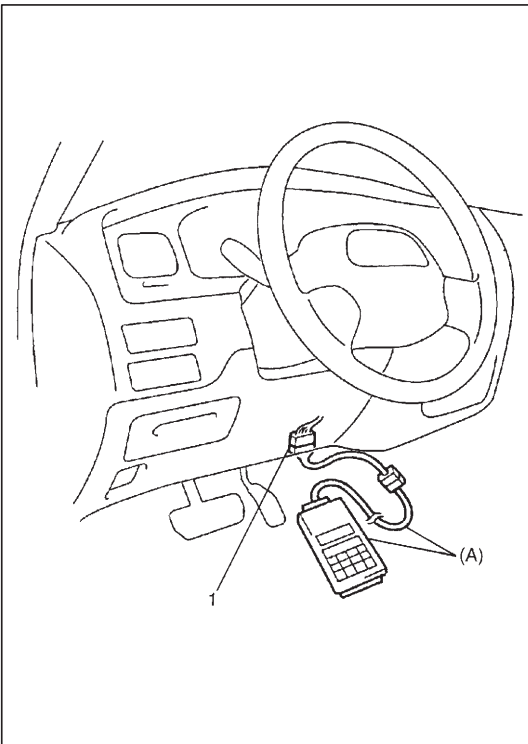

DIAGNOSTIC TROUBLE CODE CLEARANCE

[Clear DTC using SUZUKI scan tool]

- 1) Turn ignition switch OFF
- 2) After setting cartridge, connect SUZUKI scan tool to data link connector (DLC) (1) located in underside of instrument panel at driver's seat side.

Special tool

(A): SUZUKI scan tool

- 3) Turn ignition switch ON.
- 4) Erase DTC according to instructions displayed on SUZUKI scan tool. Refer to SUZUKI scan tool operator's manual for further details.
- 5) After completing the erasing, turn ignition switch OFF and disconnect SUZUKI scan tool from data link connector (DLC) (1).

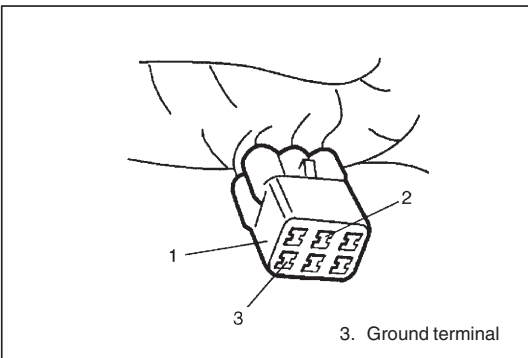

[Clear DTC not using SUZUKI scan tool]

- 1) Turn ignition switch ON.
- 2) Using service wire, ground diagnosis switch terminal (2) of monitor connector (1) five times within 10 seconds.
- 3) Perform "DTC CHECK" and confirm that only DTC No.12 (normal DTC) is displayed. If not, repeat Step 1) and 2) and check again.

DIAGNOSTIC TROUBLE CODE TABLE

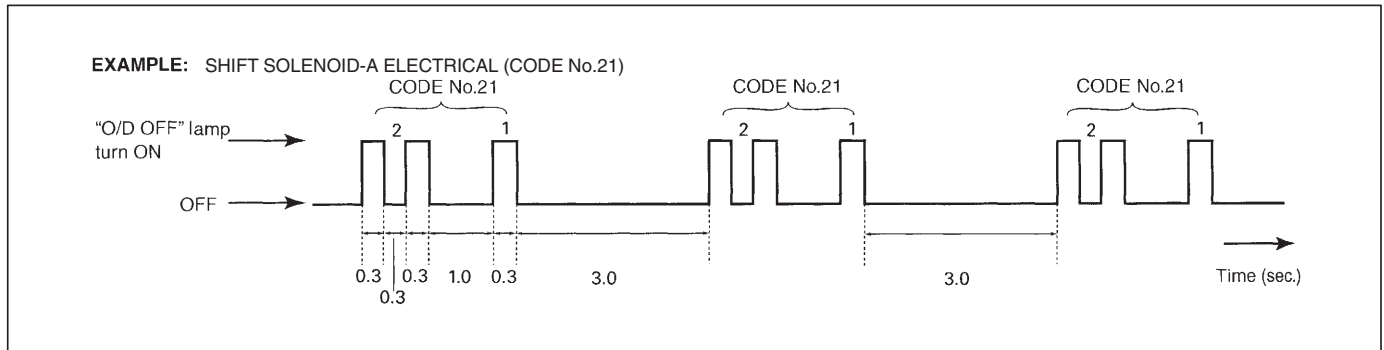

DTC NO.		“O/D OFF” Lamp Flashing Pattern of DTC (Not using scan tool)	Detecting Items
Using scan tool	Not using scan tool		
-	12		Normal
P0753	21		Shift solenoid-A (No.1) electrical
	22		
P0758	23		Torque converter clutch (lock-up) system electrical
	24		
P0743	25		Output speed sensor circuit malfunction
	26		
P0720	31		Acceleration stroke signal input malfunction
P1700	32		Transmission range sensor circuit malfunction
	33		
P0725	34		Engine speed input circuit malfunction
P0710	36		Transmission fluid temperature sensor circuit malfunction
	38		
P0715	37		Input/Turbine speed sensor circuit malfunction
P0748	41		Pressure control solenoid electrical
	42		
P1702	52		Internal malfunction of TCM
P1730	64		Engine torque signal circuit malfunction

FAIL SAFE TABLE

This function is provided by the safe mechanism that assures safe driveability even when the solenoid valve, sensor or its circuit fails.

The table below shows the fail safe function for each fail condition of solenoid, solenoid or its circuit.

DTC NO.		TROUBLE AREA	FAIL SAFE OPERATION										
P0753	21	Shift solenoid-A valve or its circuit	<ul style="list-style-type: none"> Power supply to shift solenoid, TCC solenoid and pressure control solenoid is cut. Gear position is fixed as shown below. 										
	22												
P0758	23	Shift solenoid-B valve or its circuit	<table border="1"> <thead> <tr> <th>Select lever position</th> <th>Gear position to be fixed</th> </tr> </thead> <tbody> <tr> <td>R</td> <td>Reverse</td> </tr> <tr> <td>D</td> <td>4th (O/D)</td> </tr> <tr> <td>2</td> <td>3rd</td> </tr> <tr> <td>L</td> <td>1st</td> </tr> </tbody> </table>	Select lever position	Gear position to be fixed	R	Reverse	D	4th (O/D)	2	3rd	L	1st
	Select lever position			Gear position to be fixed									
R	Reverse												
D	4th (O/D)												
2	3rd												
L	1st												
24													
P0748	41	Pressure control solenoid valve or its circuit	<ul style="list-style-type: none"> Lock-up function is inhibited to operate. (Except P1702.) 										
	42												
P1702	52	TCM											
P0743	25	TCC solenoid valve or its circuit	<ul style="list-style-type: none"> Lock-up function is inhibited to operate. When TCC solenoid circuit is shorted to power circuit and vehicle speed is less than 10 km/h (6 mile/h), gear position is fixed in 1st gear for prevention of engine stall. 										
	26												
P0705	34	Transmission range sensor or its circuit	<ul style="list-style-type: none"> In case of circuit open, selected range is set as "D" range. In case of circuit short (In case that 2 or more sensor signals are inputted), selected range is set in priority order shown below. D>2>L>R>N>P Reverse control operation, which inhibit reverse driving at "R" range while vehicle runs forward more than 7 km/h (4 mile/h), is inhibited. 										
P0725	35	Engine speed input circuit or ECM	<ul style="list-style-type: none"> Maximum value of line pressure is outputted. Engine speed which is used for A/T control is supposed to be 0 rpm. 										
P0710	36	Transmission temperature sensor or its circuit	<ul style="list-style-type: none"> A/T fluid temperature which is used for A/T control is supposed to be 200°C (392°F). Lock-up function is inhibited to operate. Line pressure control which defuse shift shock is inhibited. 										
	38												
P0715	37	Input shaft speed sensor or its circuit	<ul style="list-style-type: none"> Lock-up function is inhibited to operate. Line pressure control which defuse shift shock is inhibited. 										
P1730	64	Engine torque signal circuit or ECM	<ul style="list-style-type: none"> Maximum value of line pressure is outputted. 										

VISUAL INSPECTION

Visually check following parts and systems.

INSPECTION ITEM	REFERRING SECTION
<ul style="list-style-type: none"> ● A/T fluid ----- level, leakage, color ● A/T fluid hoses ----- disconnection, looseness, deterioration ● Accelerator cable ----- play, installation ● A/T select cable ----- installation, operation ● Engine oil ----- level, leakage ● Engine coolant ----- level, leakage ● Battery ----- fluid level, corrosion of terminal ● Connectors of electric wire harness ----- disconnection, friction ● Fuses ----- burning ● Parts ----- installation, damage ● bolt ----- looseness ● Other parts that can be checked visually ● Also check following items at engine start, if possible. <ul style="list-style-type: none"> – “O/D OFF” lamp ----- Operation – Malfunction indicator lamp ----- Operation – Charge warning lamp ----- Operation – Engine oil pressure warning lamp ----- Operation – Other parts that can be checked visually 	SECTION 0B SECTION 7B1 SECTION 6E3 SECTION 7B1 SECTION 0B SECTION 0B SECTION 6 SECTION 8 SECTION 7B1 SECTION 6 SECTION 6H SECTION 8 (SECTION 6A3 for pressure check)

A/T BASIC CHECK

This inspection is important for troubleshooting when TCM has detected no DTC and no abnormality has been noted in visual inspection. Follow flow table carefully.

Step	Action	Yes	No
1	Was “AUTOMATIC TRANSMISSION DIAGNOSTIC FLOW TABLE” performed?	Go to Step 2.	Go to “AUTOMATIC TRANSMISSION DIAGNOSTIC FLOW TABLE”.
2	Perform “ROAD TEST” in this section. Is it OK?	Go to Step 3.	Proceed to “TROUBLESHOOTING” in “ROAD TEST”.
3	Perform “MANUAL ROAD TEST” in this section. Is it OK?	Go to Step 4.	Proceed to “TROUBLESHOOTING” in “MANUAL ROAD TEST”.
4	Perform “ENGINE BRAKE TEST” in this section. Is it OK?	Go to Step 5.	Proceed to “TROUBLESHOOTING” in “ENGINE BRAKE TEST”.
5	Perform “STALL TEST” in this section. Is it OK?	Go to Step 6.	Proceed to “TROUBLESHOOTING” in “STALL TEST”.
6	Perform “TIME LAG TEST” in this section. Is it OK?	Go to Step 7.	Proceed to “TROUBLESHOOTING” in “TIME LAG TEST”.
7	Perform “LINE PRESSURE TEST” in this section. Is it OK?	Go to Step 8.	Proceed to “TROUBLESHOOTING” in “LINE PRESSURE TEST”.
8	Proceed to “TROUBLE DIAGNOSIS TABLE 1” in this section. Is trouble identified?	Repair or replace defective parts.	Go to Step 9.
9	Proceed to “TROUBLE DIAGNOSIS TABLE 2” in this section. Is trouble identified?	Repair or replace defective parts.	Proceed to “TROUBLE DIAGNOSIS TABLE 3” in this section.

TROUBLE DIAGNOSIS TABLE 1

ELECTRICAL REPAIR

Condition	Possible cause	Correction
Poor 1 → 2 shift	Shift solenoid-B valve circuit faulty	Inspect circuit for open, short and intermittent. If NG, repair.
	TCM	Inspect referring to "DTC FLOW TABLE" of P0758 in this section. If NG, replace.
Poor 2 → 3 shift	Shift solenoid-A valve circuit faulty	Inspect circuit for open, short and intermittent. If NG, repair.
	TCM	Inspect referring to "DTC FLOW TABLE" of P0753 in this section. If NG, replace.
Poor 3 → O/D shift	Shift solenoid-B valve circuit faulty	Inspect circuit for open, short and intermittent. If NG, repair.
	Output shaft speed sensor circuit faulty	
	Transmission range sensor circuit faulty	
	Acceleration stroke signal circuit faulty	
	Acceleration stroke sensor circuit faulty	Inspect circuit for open, short and intermittent referring to Section 6 or Section 6-1. If NG, repair.
	O/D off switch faulty	Refer to "DIAGNOSTIC FLOW TABLE A-1" in this section.
	4WD low switch circuit faulty	
	TCM	Inspect referring to "DTC FLOW TABLE" of P0705, P0720, P0758 and P1700 in this section. If NG, replace.
ECM	Inspect referring to "DTC FLOW TABLE" of P0121 and P0221 in this section. If NG, replace.	
Incorrect gear shift point	Shift solenoid-A or -B valve circuit faulty	Inspect circuit for open, short and intermittent. If NG, repair.
	Output shaft speed sensor circuit faulty	
	Acceleration stroke signal circuit faulty	
	Acceleration stroke sensor circuit faulty	Inspect circuit for open, short and intermittent referring to Section 6 or Section 6-1. If NG, repair.
	TCM	Inspect referring to "DTC FLOW TABLE" of P0720, P0753, P0758 and P1700 in this section. If NG, replace.
	ECM	Inspect referring to "DTC FLOW TABLE" of P0121 and P0221 in this section. If NG, replace.
Non operate TCC (lock-up) system	TCC solenoid circuit faulty	Inspect circuit for open, short and intermittent. If NG, repair.
	Input shaft speed sensor circuit faulty	
	Output shaft speed sensor circuit faulty	
	Transmission fluid temperature sensor circuit faulty	
	Transmission range sensor circuit faulty	
	Acceleration stroke signal circuit faulty	Inspect circuit for open, short and intermittent referring to Section 6 or Section 6-1. If NG, replace.
	Acceleration stroke sensor circuit faulty	
	Brake light switch circuit faulty	Refer to "DIAGNOSTIC FLOW TABLE A-2" in this section.
	4WD low switch circuit faulty	
	TCM	Inspect referring to "DTC FLOW TABLE" of P0705, P0710, P0715, P0720, P0743 and P1700 in this section. If NG, replace.
ECM	Inspect referring to "DTC FLOW TABLE" of P0121 and P0221 in this section. If NG, replace.	

ELECTRICAL REPAIR (cont'd)

Condition	Possible cause	Correction
Higher or lower stall speed	Pressure control solenoid valve circuit faulty	Inspect circuit for open, short and intermittent. If NG, replace.
	TCM	Inspect referring to "DTC FLOW TABLE" of P0748 in this section. If NG, replace.
Higher or lower line pressure	Pressure control solenoid valve circuit faulty	Inspect circuit for open, short and intermittent. If NG, replace.
	TCM	Inspect referring to "DTC FLOW TABLE" of P0748 in this section. If NG, replace.
Excessive "N" → "D" or "N" → "R" time lag	Pressure control solenoid valve circuit faulty	Inspect circuit for open, short and intermittent. If NG, replace.
	TCM	Inspect referring to "DTC FLOW TABLE" of P0748 in this section. If NG, replace.

TROUBLE DIAGNOSIS TABLE 2**ON-VEHICLE REPAIR**

Condition	Possible cause	Correction
Unable to run in all range	Defective manual valve	Replace.
	Clogged oil strainer	Wash strainer.
Poor 1 → 2 shift, excessive shock or slippage	Defective shift solenoid-B valve	Inspect. If NG, replace.
	Defective valve body component	Replace valve body assembly.
Poor 2 → 3 shift, excessive shock or slippage	Defective shift solenoid-A valve	Inspect. If NG, replace.
	Defective valve body component	Replace valve body assembly.
Poor 3 → O/D shift, excessive shock or slippage	Defective shift solenoid-B valve	Inspect. If NG, replace.
	Defective valve body component	Replace valve body assembly.
Incorrect shift point	Defective shift solenoid-A or -B	Inspect. If NG, replace.
	Defective output shaft speed sensor	
	Defective acceleration stroke sensor	Inspect referring to Section 6E3. If NG, replace.
	Defective valve body component	Replace valve body assembly.
Non operate TCC (lock-up) system	Defective TCC solenoid valve	Inspect. If NG, replace.
	Defective valve body component	Replace valve body assembly.
	Defective input shaft speed sensor	Inspect. If NG, replace.
	Defective output shaft speed sensor	
	Defective 4WD low switch	
	Defective transmission fluid temperature sensor	
	Defective acceleration stroke sensor	Inspect referring to Section 6E3. If NG, replace.
Defective stop light switch	Inspect referring to Section 5. If NG, replace.	
Excessive "N" → "D" or "N" → "R" time lag	Defective pressure control solenoid valve	Inspect. If NG, replace valve body assembly.
	Defective primary regulator valve	Replace valve body assembly.
	Clogged oil strainer	Wash strainer.

TROUBLE DIAGNOSIS TABLE 3**OFF-VEHICLE REPAIR**

Condition	Possible cause	Correction
Unable to run in all range	Defect in torque converter	Replace.
	Defective oil pump	Inspect. If NG, replace.
	Seized or broken planetary gear	Repair or replace.
Poor 1 → 2 shift, excessive shock or slippage	Defective 2nd brake	Replace.
	Defective one-way clutch No.1	Replace
Poor 2 → 3 shift, excessive shock or slippage	Defective direct clutch	Replace.
Poor 3 → O/D shift, excessive shock or slippage	Defective O/D brake	Replace.
Non operate TCC (lock-up) system	Defective transmission range sensor	Inspect. If NG, replace.
	Defect in torque converter	Replace valve body assembly.
Excessive "N" → "D" time lag	Defective forward clutch	Replace.
	Defective one-way clutch No.2	Replace.
	Leakage from "D" range fluid pressure circuit	Overhaul or replace valve body assembly.
Excessive "N" → "R" time lag	Defective direct clutch	Replace.
	Defective reverse brake	Replace.
	Leakage from "R" range fluid pressure circuit	Overhaul or replace valve body assembly.
Poor engine brake in downshift to "2" range	Defective second coast brake	Replace.
Poor engine brake in downshift to "L" range	Defective reverse brake	Replace.
Abnormal noise in "P" or "N" range	Worn oil pump	Inspect. If NG, replace.

ROAD TEST

This test is to check if upshift and downshift take place at specified speed while actually driving vehicle on a level road.

WARNING:

- Carry out test in very little traffic area to prevent an accident.
- Test requires 2 persons, a driver and a tester.

- 1) Warm up engine.
- 2) With engine running at idle, shift select lever “D”.
- 3) Accelerate vehicle speed by depressing accelerator pedal gradually.
- 4) While driving in “D” range, check if gear shift and lock-up occur properly as shown in “GEAR SHIFT DIAGRAM AND LOCK-UP DIAGRAM” in this section.

TROUBLESHOOTING

Condition	Possible cause	Correction
1 → 2 upshift fails to occur	Malfunction of shift solenoid-B valve	Inspect shift solenoid-B valve. If NG, replace.
	Defective valve body component	Replace valve body assembly.
	Defective 2nd brake	Replace.
	Defective one-way clutch No.1	Replace.
2 → 3 upshift fails to occur	Malfunction of shift solenoid-A valve	Inspect shift solenoid-A valve and its circuit. If NG, replace.
	Defective valve body component	Replace valve body assembly.
	Defective direct clutch	Replace.
3 → O/D upshift fails to occur	Malfunction of shift solenoid-B valve	Inspect. If NG, replace.
	Defective valve body component	Replace valve body assembly.
	Malfunction of output shaft speed sensor	Inspect. If NG, replace.
	Malfunction of acceleration stroke sensor	Inspect referring to Section 6E3. If NG, replace.
	Malfunction of O/D off switch	Refer to “DIAGNOSTIC FLOW TABLE A-1” in this section.
	Malfunction of 4WD low switch	
	Malfunction of transmission range sensor	
Defective O/D brake	Replace.	
Gear shift point is incorrect	Defective shift solenoid-A or -B valve	Inspect. If NG, replace.
	Malfunction of output shaft speed sensor	Inspect. If ING, replace.
	Malfunction of acceleration stroke sensor	Inspect referring to Section 6E3. If NG, replace.
	Defective valve body component	Replace valve body assembly.
TCC (lock-up) function does not operate	Malfunction of TCC (lock-up) solenoid	Inspect. If NG, replace.
	Defective valve body component	Replace valve body assembly.
	Malfunction of input shaft speed sensor	Inspect. If NG, replace.
	Malfunction of output shaft speed sensor	Inspect. If NG, replace.
	Malfunction of acceleration stroke sensor	Inspect referring to Section 6E3. If NG, replace.
	Malfunction of brake light switch	Refer to “DIAGNOSTIC FLOW TABLE A-2” in this section.
	Malfunction of 4WD low switch	
	Malfunction of transmission fluid temperature sensor	
	Malfunction of transmission range sensor	
Defective torque converter	Replace.	

MANUAL ROAD TEST

This test check the gear being used in “L”, “2” or “D” range when driven with unoperated gear shift control system. Test drive vehicle on a level road.

NOTE:

Before this test, check diagnostic trouble code (DTC).

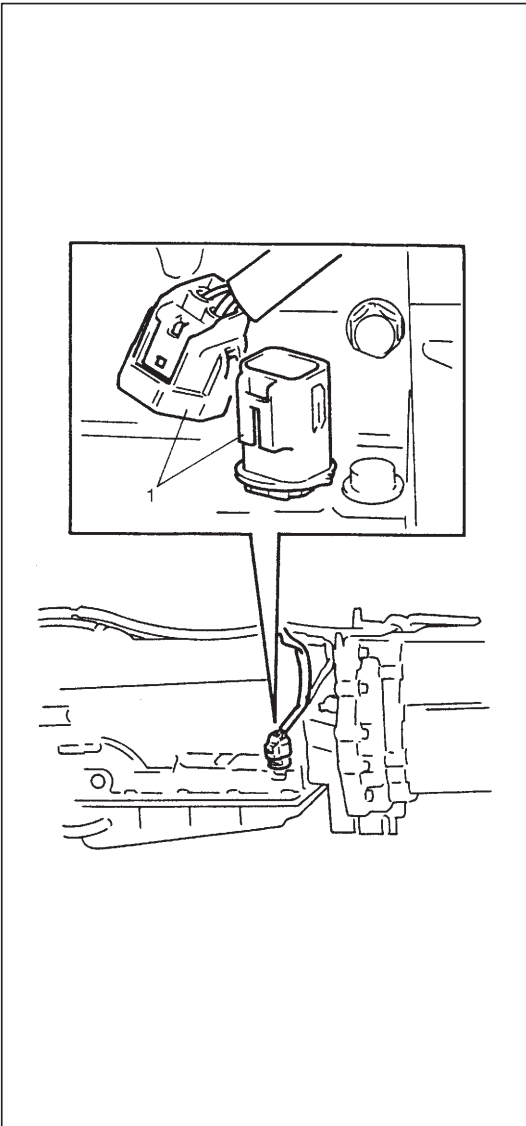

- 1) Disconnect shift solenoid connector (1) on transmission.

WARNING:

To avoid the danger of being burned, do not touch the hot exhaust system when disconnecting shift solenoid coupler (1).

- 2) With select lever in “P”, start engine and warm it up.
- 3) With select lever in “L” range, start vehicle and accelerate to 20 km/h (12.5 mile/h). Check in this state that 1st gear is being used.
- 4) At 20 km/h (12.5 mile/h), shift select lever to “2” range and accelerate to 40 km/h (25 mile/h). Check in this state that 3rd gear is being used.
- 5) At 40 km/h (25 mile/h), shift select lever to “D” range and check that O/D gear is used when speed is higher than 40 km/h (25 mile/h).
- 6) After above checks, stop vehicle then engine, and connect shift solenoids coupler (1) with ignition switch OFF.

WARNING:

To avoid the danger of being burned, do not touch the hot exhaust system when connecting shift solenoid coupler (1).

- 7) Clear DTC with scan tool.

TROUBLESHOOTING

Condition	Possible cause	Correction
Selected gear is not correct	Defective valve body component	Replace valve body assembly.
	Defective clutch or brake	Inspect clutch and brake. If any parts are faulty, replace them.

ENGINE BRAKE TEST

WARNING:

Before test, make sure that there is no vehicle behind so as to prevent rear-end collision.

- 1) While driving vehicle in 3rd gear of “D” range, shift select lever down to “2” range and check if engine brake operates.
- 2) In the same way as in step 1, check engine brake for operation when select lever is shifted down to “L” range.
- 3) If engine brake fails to operate in above tests, possible causes for such failure are as follows. Check each part which is suspected to be the cause.

TROUBLESHOOTING

Condition	Possible cause	Correction
Failure to operate when shifted down to “2” range	Defective second coast brake	Replace.
Failure to operate when shifted down to “L” range	Defective reverse brake	Replace.

STALL TEST

This test is to check overall performance of automatic transmission and engine by measuring stall speed at “D” and “R” ranges. Be sure to perform this test only when transmission fluid is at normal operating temperature and its level is between FULL and LOW marks.

CAUTION:

- **Do not run engine at stall more than 5 seconds continuously, for fluid temperature may rise excessively high.**
- **After performing stall test, be sure to leave engine running at idle for longer than 30 seconds before another stall test.**

- 1) Apply parking brake and block wheels.
- 2) Install tachometer.
- 3) Start engine with select lever shifted to “P”.
- 4) Depress brake pedal fully.
- 5) Shift select lever to “D” and depress accelerator pedal fully while watching tachometer. Read engine rpm quickly when it has become constant (stall speed).
- 6) Release accelerator pedal immediately after stall speed is checked.
- 7) In the same way, check stall speed in “R” range.
- 8) Stall speed should be within the following specification.

Stall speed:

2,450 – 2,750 rpm

TROUBLESHOOTING

Condition	Possible cause	Correction
Lower than standard level	Engine output torque failure	Inspect and repair engine.
	Defective one-way clutch of torque converter	Replace.
Higher than standard level in "D" range	Defective pressure control solenoid valve (Low line pressure)	Inspect. If NG, replace valve body assembly.
	Primary regulator valve (Low line pressure)	Replace valve body assembly.
	Slippery forward clutch	Replace.
	Defective one-way clutch No.2	Replace.
	Leakage from "D" range fluid pressure circuit	Overhaul or replace valve body assembly.
Higher than standard level in "R" range	Defective pressure control solenoid valve (Low line pressure)	Inspect. If NG, replace valve body assembly.
	Defective primary regulator valve (Low line pressure)	Replace valve body assembly.
	Slippery direct clutch	Replace.
	Slippery reverse brake	Replace.
	Leakage from "R" range fluid pressure circuit	Overhaul or replace valve body assembly.
High than standard level in both "D" and "R" range	Defective pressure control solenoid valve (Low line pressure)	Inspect. If NG, replace valve body assembly.
	Defective primary regulator valve (Low line pressure)	Replace valve body assembly.
	Clogged oil strainer	Wash strainer.
	Defective O/D clutch and O/D one-way clutch	Replace.
	Malfunction of oil pump	Replace.
	Leakage from fluid pressure circuit	Overhaul or replace valve body assembly.

TIME LAG TEST

This test is to check conditions of clutch, reverse brake and fluid pressure. "Time lag" means time elapsed since select lever is shifted with engine idling till shock is felt.

- 1) With chocks placed before and behind front and rear wheels respectively, depress brake pedal.
- 2) Start engine.
- 3) With stop watch ready, shift select lever from "N" to "D" range and measure time from that moment till shock is felt.
- 4) Similarly measure time lag by shifting select lever from "N" to "R" range.

Specification for time lag:

"N" → "D"	Less than 1.2 sec.
"N" → "R"	Less than 1.5 sec.

NOTE:

- When repeating this test, be sure to wait at least one minute after select lever is shifted back to "N" range.
- Engine should be warmed up fully for this test.

TROUBLESHOOTING

Condition	Possible cause	Correction
"N" → "D" time lag exceeds specification	Defective pressure control solenoid valve (Low line pressure)	Inspect. If NG, replace valve body assembly.
	Defective primary regulator valve (Low line pressure)	Replace valve body assembly.
	Clogged oil strainer	Wash strainer.
	Defective of oil pump	Inspect. If NG, replace.
	Leakage from "D" range fluid pressure circuit	Overhaul or replace valve body assembly.
	Defective forward clutch	Replace.
	Defective one-way clutch No.2	Replace.
"N" → "R" time lag exceeds specification	Defective pressure control solenoid valve (Low line pressure)	Inspect. If NG, replace valve body assembly.
	Primary regulator valve (Low line pressure)	Replace valve body assembly.
	Defective of oil pump	Inspect. If NG, replace.
	Clogged oil strainer	Wash strainer.
	Leakage from "R" range fluid pressure circuit	Overhaul or replace valve body assembly.
	Defective direct clutch	Replace.
	Defective reverse brake	Replace.

LINE PRESSURE TEST

Purpose of this test is to check operating conditions of each part by measuring fluid pressure in fluid pressure line. Line pressure test requires following conditions.

- Automatic fluid is at normal operating temperature (70 to 80 °C/ 158 – 176 °F).
 - Fluid is filled to proper level (between FULL HOT and LOW HOT on dipstick).
 - Air conditioner switch is turned OFF.
- 1) Apply parking brake securely and place checks against wheels.

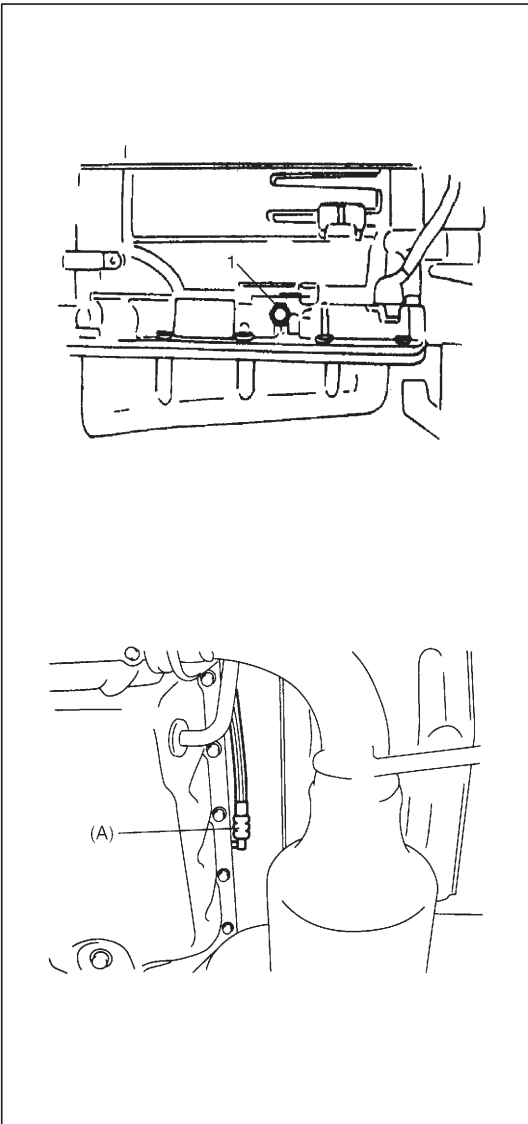

- 2) Attach oil pressure gauge to fluid pressure check hole (1) in transmission case.

Special tool
(A): 09925-37810

CAUTION:
After attaching oil pressure gauge, check that not fluid leakage exists.

- 3) Depress foot brake fully, run engine at idle and stall.
- 4) Check fluid pressure in “D” or “R” range within the following specification.

CAUTION:
Do not continue running engine at stall speed longer than 5 seconds.

	“D” range	“R” range
Idle speed	4.0 – 4.6 kg/cm ² 57 – 65 psi	5.6 – 6.7 kg/cm ² 80 – 95 psi
Stall speed	13.0 – 14.8 kg/cm ² 185 – 210 psi	16.6 – 20.0 kg/cm ² 236 – 284 psi

- 5) If check result is OK, disconnect special tool, then tighten transmission case plug to specified torque.

Tightening torque
Transmission case plug: 7.5 N·m (0.75 kg·m, 5.5 lb·ft)

TROUBLESHOOTING

Condition	Possible cause	Correction
Higher than standard level in each range	Defective pressure control solenoid valve	Inspect. If NG, replace valve body assembly.
	Defective primary regulator valve	Replace valve body assembly.
Lower than standard level in each range	Defective pressure control solenoid valve	Inspect. If NG, replace valve body assembly.
	Primary regulator valve	Replace valve body assembly.
	Clogged oil strainer	Wash strainer.
	Defective oil pump	Inspect. If NG, replace.
	Leakage from fluid pressure circuit	Overhaul or replace valve body assembly
Lower than standard level only in "D" range	Leakage from "D" range fluid pressure circuit	Overhaul or replace valve body assembly
Lower than standard level only in "R" range	Leakage from "R" range fluid pressure circuit	Overhaul or replace valve body assembly

"P" RANGE TEST

- 1) Stop vehicle on a slope of 5 degrees or more, shift select lever to "P" range and at the same time apply parking brake.
- 2) After stopping engine, depress brake pedal and release parking brake.
- 3) Then, release brake pedal gradually and check that vehicle remains stationary.
- 4) Depress brake pedal and shift select lever to "N" range.
- 5) Then, release brake pedal gradually and check that vehicle moves.

WARNING:

Before test, check to make sure no one is around vehicle or down on a slope and keep watchful for safety during test.

TABLE A-1: NO GEAR SHIFT TO O/D**SYSTEM DESCRIPTION**

TCM does not shift to O/D gear under any of the following conditions.

- O/D off switch is ON. (“O/D OFF” lamp ON.)
- 4WD low switch is ON.
- Output shaft speed sensor is in faulty condition. (P0720)

TROUBLESHOOTING**WARNING**

- **When performing a road test, select a place where there is no traffic or possibility of a traffic accident and be very careful during testing to avoid occurrence of an accident.**
- **Road test should be carried out with 2 persons, a driver and tester, on a level road.**

Step	Action	Yes	No
1	Was “A/T DIAGNOSTIC FLOW TABLE” in this section performed?	Go to Step 2.	Go to “A/T DIAGNOSTIC FLOW TABLE” in this section.
2	Check DTC. Is DTC P0720 detected?	Perform “TROUBLE DIAGNOSIS TABLE” to repair and retry.	Go to Step 3.
3	Perform running test under the following conditions and check voltage between terminal E203-4 of TCM connector and ground, terminal E203-3 of TCM connector and ground. ● O/D off switch is OFF. ● Selector lever is in “D” range. ● Transfer lever is in “2H” position. ● Drive vehicle with 4th gear condition referring to “GEAR SHIFT DIAGRAM” in this section. Is each terminal voltage 0 – 1 V?	Faulty shift solenoid valve, circuit or transmission.	“GRN” or “GRN/RED” circuit shorted to power circuit. If wire is OK, go to Step 4.
4	“O/D” off switch signal inspection. With ignition switch ON, check voltage between terminal E202-3 of TCM connector and ground. O/D off switch OFF : 10 – 14 V O/D off switch ON : 0 – 1 V Is result as specified?	Go to Step 5.	Faulty O/D off switch or its circuit. If OK, substitute a known-good TCM and recheck.
5	4WD low switch signal inspection With ignition switch ON, check voltage between terminal E202-1 of TCM connector and ground. Transfer gear position “4L” or “N” : 0 – 1 V Transfer gear position “2H” or “4H” : 10 – 14 V Is result as specified?	Substitute a known-good TCM and recheck.	Faulty 4WD low switch or its circuit. If OK, substitute a known-good TCM and recheck.

TABLE A-2: NO LOCK-UP OCCURS**SYSTEM DESCRIPTION**

TCM turns TCC solenoid OFF under any of the following conditions.

- Brake light switch is ON.
- 4WD low switch is ON.
- Transmission fluid temperature sensor circuit is in faulty condition. (P0710)
- Input shaft speed sensor is in faulty condition. (P0715)
- Output shaft speed sensor is in faulty condition. (P0720)
- TCC (lock-up) system circuit is in faulty condition. (P0743)
- Pressure control solenoid circuit is in faulty condition. (P0748)
- Shift solenoid circuit is in faulty condition. (P0753/P0758)
- Acceleration stroke signal circuit is in faulty condition. (P1700)

TROUBLESHOOTING**WARNING**

- **When performing a road test, select a place where there is no traffic or possibility of a traffic accident and be very careful during testing to avoid occurrence of an accident.**
- **Road test should be carried out with 2 persons, a driver and tester, on a level road.**

Step	Action	Yes	No
1	Was "A/T DIAGNOSTIC FLOW TABLE" in this section performed?	Go to Step 2.	Go to "A/T DIAGNOSTIC FLOW TABLE" in this section.
2	Check DTC. Is DTC P0710, P0715, P0720, P0743, P0748, P0753, P0758 or P1700 detected?	Perform "TROUBLE DIAGNOSIS TABLE" to repair and retry.	Go to Step 3.
3	Perform running test under the following conditions and check voltage between terminal E203-12 of TCM connector and ground. <ul style="list-style-type: none"> ● Selector lever is in "D" range. ● Transfer lever is in "2H" position. ● Brake pedal is released. ● Drive vehicle with TCC ON condition referring to "TCC LOCK-UP DIAGRAM" in this section. Is terminal voltage about 10 – 14 V?	Faulty TCC solenoid valve, circuit or transmission.	Go to Step 4.
4	Brake light switch signal inspection. With ignition switch ON, check voltage between terminal E202-16 of TCM connector and ground. Brake pedal is released: 0 – 1 V Brake pedal is depressed: 10 – 14 V Is result as specified?	Go to Step 5.	Mis-adjusted brake light switch, faulty brake light switch or its circuit. If OK, substitute a known-good TCM and recheck.
5	4WD low switch signal inspection With ignition switch ON, check voltage between terminal E202-1 of TCM connector and ground. Transfer gear position "4L" or "N": 0 – 1 V Transfer gear position "2H" or "4H": 10 – 14 V Is result as specified?	Substitute a known-good TCM and recheck.	Faulty 4WD low switch or its circuit. If OK, substitute a known-good TCM and recheck.

TABLE B-1: "O/D OFF" LAMP CIRCUIT CHECK ("O/D OFF" LAMP DOESN'T LIGHT AT IGNITION SWITCH ON)

WIRING DIAGRAM

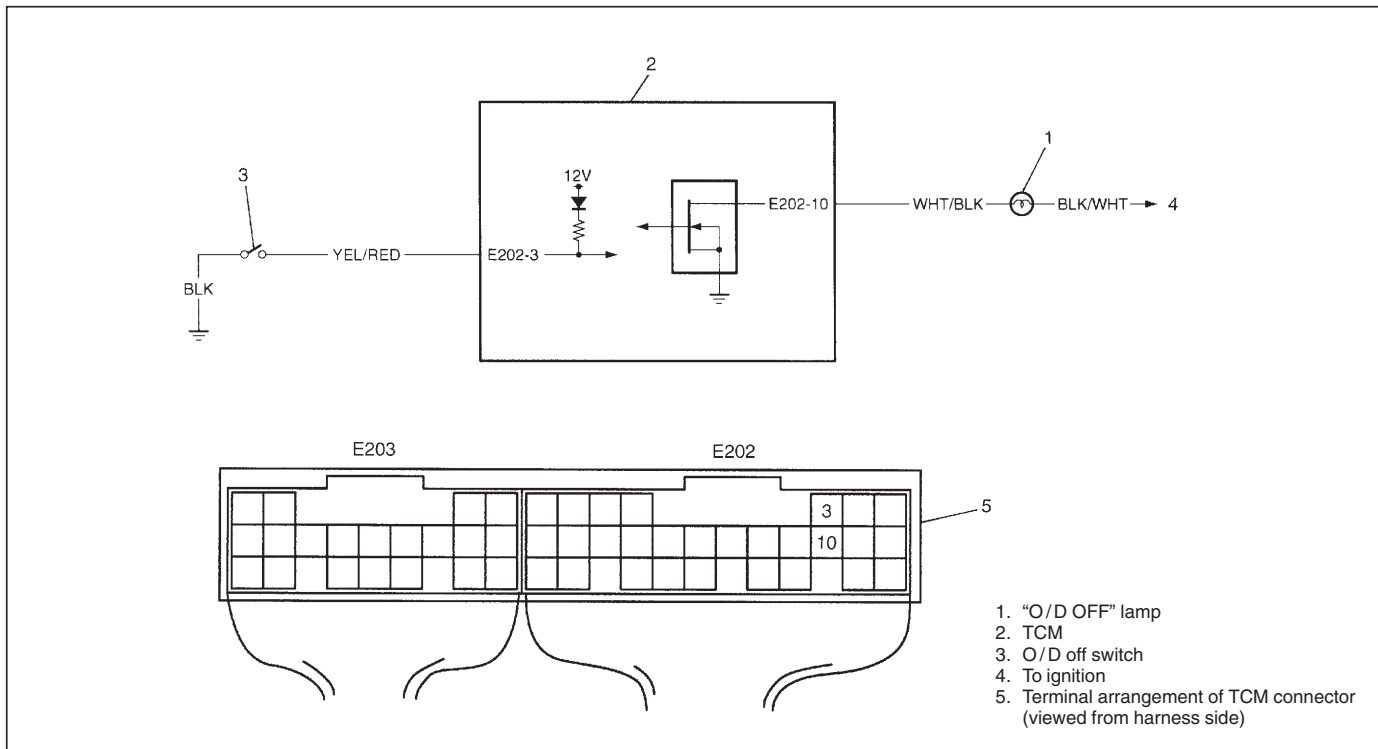

TROUBLESHOOTING

Step	Action	Yes	No
1	"O/D OFF" lamp circuit check: 1) With ignition switch OFF, disconnect couplers from TCM. 2) Using service wire, connect E202-10 terminal of disconnected TCM harness side connector and ground. Does "O/D OFF" light turn ON at ignition switch ON?	Poor E202-10 terminal connection. If OK, substitute a know-good TCM and recheck.	Bulb burned out or faulty "WHT/BLK" or "BLK/WHT" wire.

TABLE B-2: "O/D OFF" LAMP CIRCUIT CHECK ("O/D OFF" LAMP COMES ON STEADILY)

WIRING DIAGRAM

Refer to "TABLE B-1" in this section.

TROUBLESHOOTING

Step	Action	Yes	No
1	Check O/D off switch status. Press O/D off switch button (1). Does "O/D OFF" lamp come ON steadily?	Go to Step 2.	System is OK.
2	Check lamp circuit for short. 1) Turn ignition switch OFF and disconnect TCM connectors. 2) Turn ignition switch ON. Does "O/D OFF" lamp come ON steadily?	"WHT/BLK" circuit shorted to ground.	Go to Step 3.
3	Check O/D off switch circuit. 1) Check resistance between terminal E202-3 of disconnected TCM harness side connector and body ground with O/D off switch button (1) released. Is continuity indicated?	Go to Step 4.	Check TCM ground circuit for open. If ground circuit is OK, substitute a known-good TCM and recheck.
4	Check O/D off switch for operation. 1) Remove console box. 2) Disconnect O/D off switch connector. 3) Check continuity between switch terminals under each condition below. O/D off switch operation With O/D off switch button (1) released: No continuity With O/D off switch button (1) pressed: Continuity Is check result satisfactory?	"YEL/RED" circuit shorted to ground.	Replace O/D off switch.

Fig. for Step 1

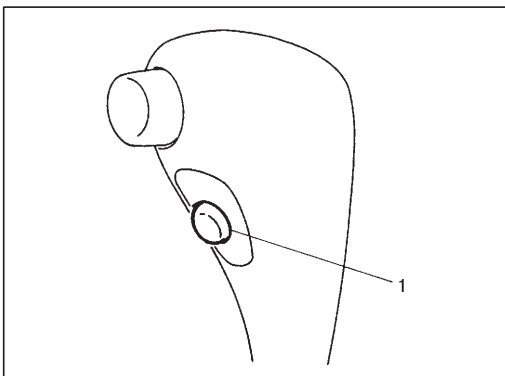
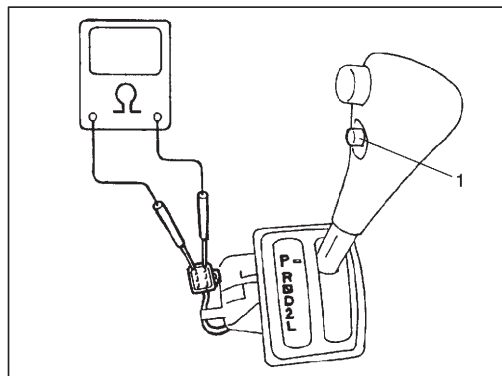

Fig. for Step 4



INSPECTION OF TCM AND ITS CIRCUITS

TCM and its circuits can be checked at TCM wiring connectors by measuring voltage and resistance.

CAUTION:

TCM cannot be checked by itself, it is strictly prohibited to connect voltmeter or ohmmeter to TCM with connector disconnected from it.

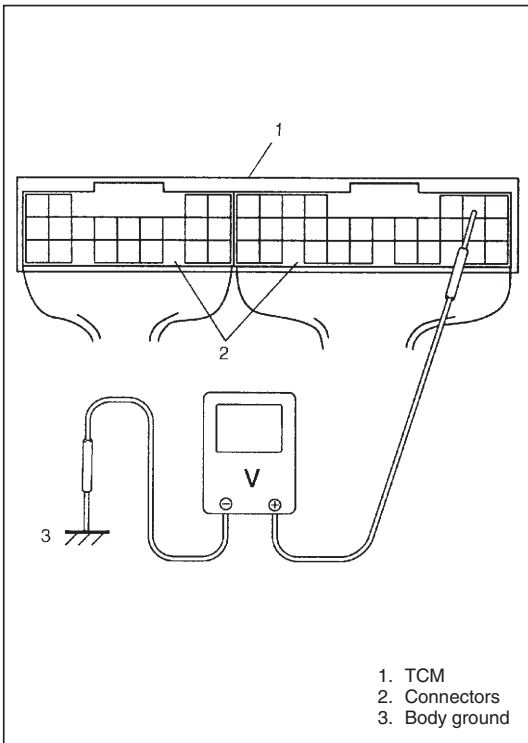

INSPECTION

- 1) Remove TCM from vehicle referring to "TRANSMISSION CONTROL MODULE" in this section.
- 2) Connect TCM connectors to TCM.
- 3) Check voltage at each terminal of connectors connected.

NOTE:

As each terminal voltage is affected by battery voltage, confirm that it is 11 V or more when ignition switch is ON.

WIRE HARNESS AND CONNECTORS

Refer to Section 8A ("WIRING DIAGRAM" manual.)

DTC P0705 (DTC NO.34) TRANSMISSION RANGE SENSOR (SWITCH) CIRCUIT MALFUNCTION

WIRING DIAGRAM

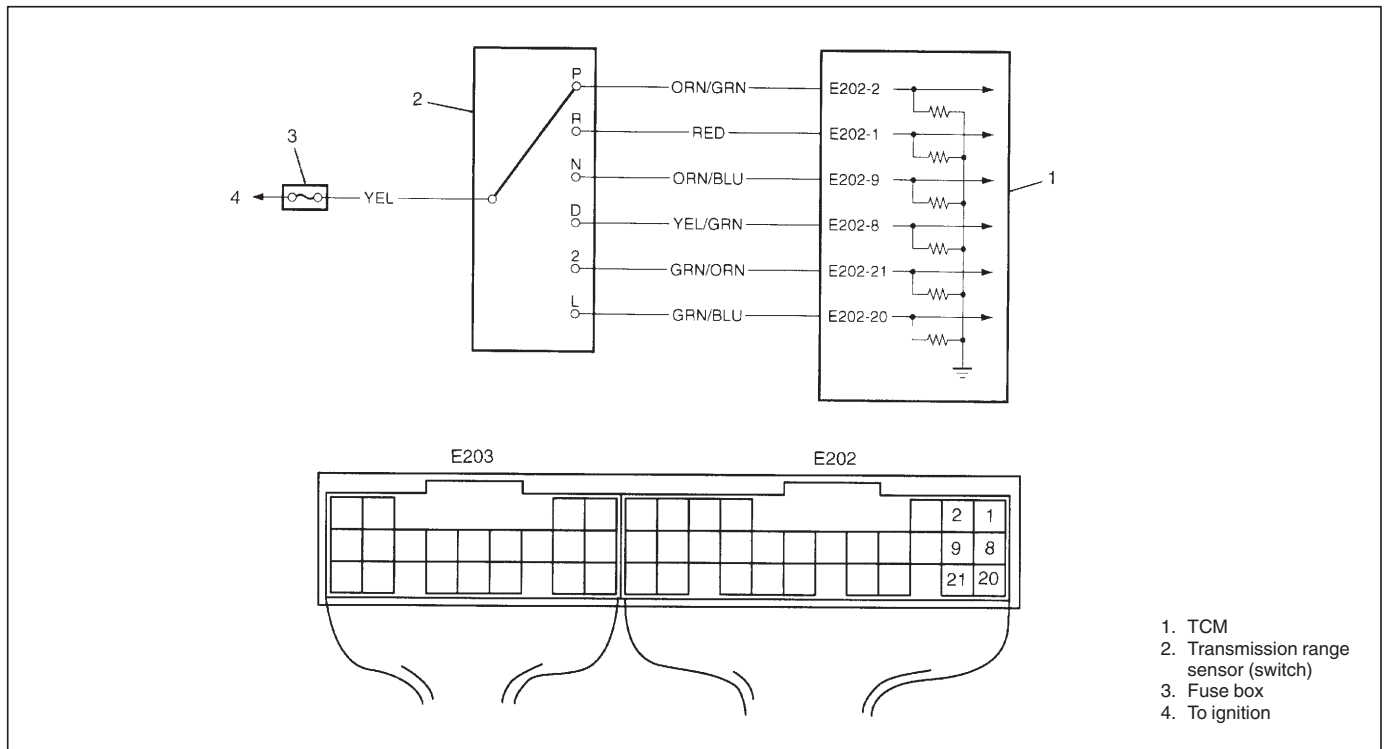

DTC DETECTING CONDITION AND TROUBLE AREA

DTC DETECTING CONDITION	TROUBLE AREA
<ul style="list-style-type: none"> Transmission range switch signal (P, R, N, D, 2 or L) is not inputted for 30 sec. at more than 30 km/h (19 mile/h) vehicle speed and more than 1500 rpm engine speed. or Multiple signals are inputted simultaneously for 10 sec. 	<ul style="list-style-type: none"> Transmission range sensor (switch) maladjusted. Transmission range sensor (switch) or its circuit malfunction. TCM

DTC CONFIRMATION PROCEDURE

WARNING:

- When performing a road test, select a place where there is no traffic or possibility of a traffic accident and be very careful during testing to avoid occurrence of an accident.
- Road test should be carried out with 2 persons, a driver and a tester, on a level road.

- Connect scan tool to DLC with ignition switch OFF.
- Clear DTC in TCM memory by using scan tool and start engine.
- Shift A/T selector lever to each of L, 2, D, N, R and P ranges for 20 seconds each.
- Increase vehicle speed to about 40 km/h (25 mile/h) in D range.
- Keep driving above vehicle speed for 40 seconds.
- Release accelerator pedal, decrease vehicle speed and stop vehicle.
- Check DTC.

TROUBLESHOOTING

Step	Action	Yes	No
1	Was "A/T DIAGNOSTIC FLOW TABLE" in this section performed?	Go to Step 2.	Go to "A/T DIAGNOSTIC FLOW TABLE" in this section.
2	Do you have SUZUKI scan tool?	Go to Step 3.	Go to Step 4.
3	Check Transmission range sensor (switch) circuit for operation. Check by using SUZUKI scan tool: 1) Connect SUZUKI scan tool to DLC with ignition switch OFF. 2) Turn ignition switch ON and check transmission range signal (P, R, N, D, 2 or L) on display when shifting select lever to each range. Is applicable range indicated? Are check results satisfactory?	Intermittent trouble. Check for intermittent referring to "INTERMITTENT AND POOR CONNECTION" in Section 0A.	Go to Step 5.
4	Check Transmission range sensor (switch) circuit for operation. Check by not using SUZUKI scan tool: 1) Turn ignition switch ON. 2) Check voltage at terminals E202-1, E202-2, E202-8, E202-9, E202-20 and E202-21 respectively with select lever shifted to each range. Taking terminal E202-21 as an example, is battery voltage indicated only when select lever is shifted to "2" range and 0 V for other ranges as shown in figure? Check voltage at other terminals likewise, referring to figure. Are check results satisfactory?	Intermittent trouble. Check for intermittent referring to "INTERMITTENT AND POOR CONNECTION" in Section 0A.	Go to Step 5.
5	Check select cable for adjustment referring to "SELECT CABLE ADJUSTMENT" in this section. Is it adjusted correctly?	Go to Step 6.	Adjust.
6	Check transmission range switch for installation position. 1) Shift select lever to "N" range. 2) Check that "N" reference line on switch and center line on shaft are aligned. Are they aligned?	Go to Step 7.	Adjust.
7	Check transmission range sensor (switch) referring to "TRANSMISSION RANGE SENSOR" in this section. Are check results satisfactory?	"YEL", "ORN/GRN", "RED", "ORN/BLU", "YEL/GRN", "GRN/ORN" or "GRN/BLU" circuit open or short. If wires and connections are OK, substitute a known-good TCM and recheck.	Replace Transmission range sensor.

Fig. for Step 3

		Terminal					
		E202-2	E202-1	E202-9	E202-8	E202-21	E202-20
Select lever position	P	B + V	0 V	0 V	0 V	0 V	0 V
	R	0 V	B + V	0 V	0 V	0 V	0 V
	N	0 V	0 V	B + V	0 V	0 V	0 V
	D	0 V	0 V	0 V	B + V	0 V	0 V
	2	0 V	0 V	0 V	0 V	B + V	0 V
	L	0 V	0 V	0 V	0 V	0 V	B + V

DTC P0710 (DTC NO.36/38) TRANSMISSION FLUID TEMPERATURE SENSOR CIRCUIT MALFUNCTION

WIRING DIAGRAM

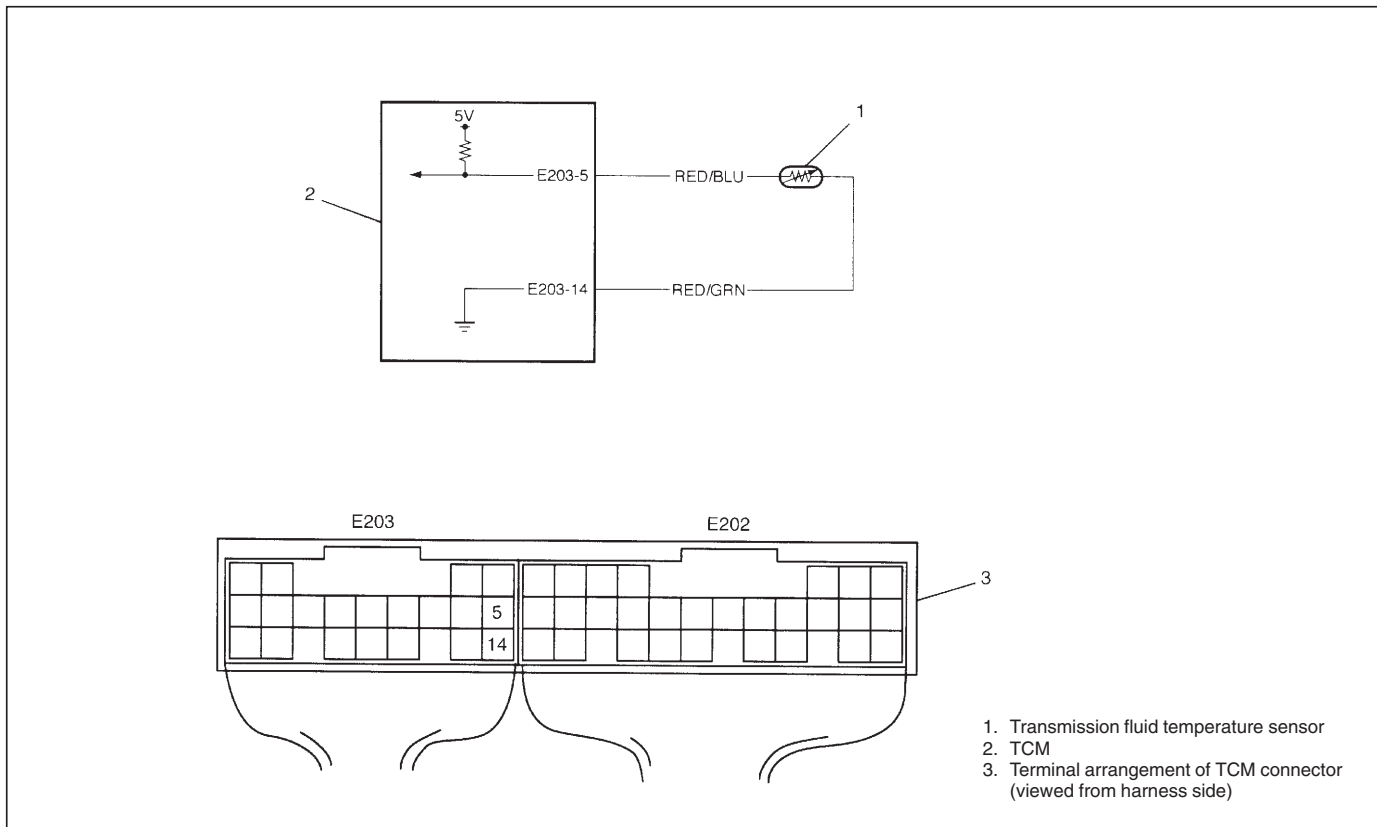

DTC DETECTING CONDITION AND TROUBLE AREA

DTC DETECTING CONDITION	TROUBLE AREA
<ul style="list-style-type: none"> ● Engine speed is more than 400 rpm and engine running time at "R", "D", "2" or "L" range is more than 15 minutes. and ● Transmission fluid temperature sensor output voltage is too low or too high. 	<ul style="list-style-type: none"> ● Transmission fluid temperature sensor ● Transmission fluid temperature sensor circuit ● TCM

DTC CONFIRMATION PROCEDURE

WARNING

- When performing a road test, select a place where there is no traffic or possibility of a traffic accident and be very careful during testing to avoid occurrence of an accident.
- Road test should be carried out with 2 persons, a driver and tester, on a level road.

- 1) Connect scan tool to DLC with ignition switch OFF.
- 2) Clear DTC in TCM memory by using scan tool.
- 3) Start engine and drive vehicle for 15 minutes or more.
- 4) Stop vehicle and check DTC by using scan tool.

TROUBLESHOOTING

Step	Action	Yes	No
1	Was "A/T DIAGNOSTIC FLOW TABLE" in this section performed?	Go to Step 2.	Go to "A/T DIAGNOSTIC FLOW TABLE" in this section.
2	<p>Check transmission fluid temperature sensor circuit.</p> <p>1) Turn ignition switch OFF and disconnect TCM connectors.</p> <p>2) Check for proper connection to output transmission fluid temperature sensor at terminal E203-5 and E203-14.</p> <p>3) If OK, check resistance between terminal E203-5 and E203-14 of disconnected harness side TCM connector.</p> <p>Is it 5800 – 7090 Ω (at 10°C (50°F))?</p> <p>Resistance of transmission fluid temperature sensor Reference: 231 – 263 Ω (at 110°C (230°F)) 105 – 117 Ω (at 145°C (293°F))</p>	<p>Intermittent trouble or faulty TCM.</p> <p>Check for intermittent referring to "INTERMITTENT AND POOR CONNECTION" in Section 0A.</p> <p>If OK, substitute a known-good TCM and recheck.</p>	Go to Step 3.
3	<p>Check transmission fluid temperature sensor resistance.</p> <p>1) With ignition switch OFF, disconnect shift solenoid connector.</p> <p>2) Check resistance between terminal "1" and "2" of shift solenoid connector. (See figure.)</p> <p>Is it 5800 – 7090 Ω (at 10°C (50°F))?</p> <p>Resistance of transmission fluid temperature sensor Reference: 231 – 263 Ω (at 110°C (230°F)) 105 – 117 Ω (at 145°C (293°F))</p>	<p>"RED/BLU" or "RED/GRN" circuit open, shorted each other, intermittent trouble or faulty TCM.</p> <p>If wire and connection are OK, substitute a known-good TCM and recheck.</p>	Faulty transmission fluid temperature sensor.

Fig. for Step 3

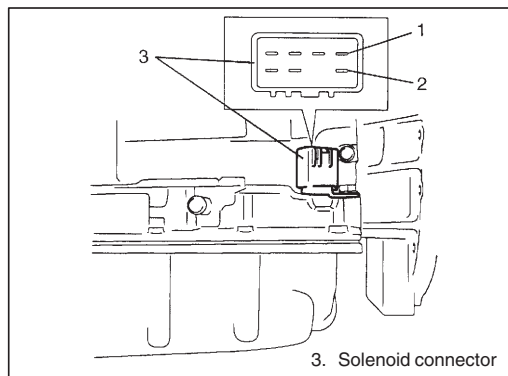

DTC P0715 (DTC NO.37) INPUT/TURBINE SPEED SENSOR CIRCUIT MALFUNCTION

WIRING DIAGRAM

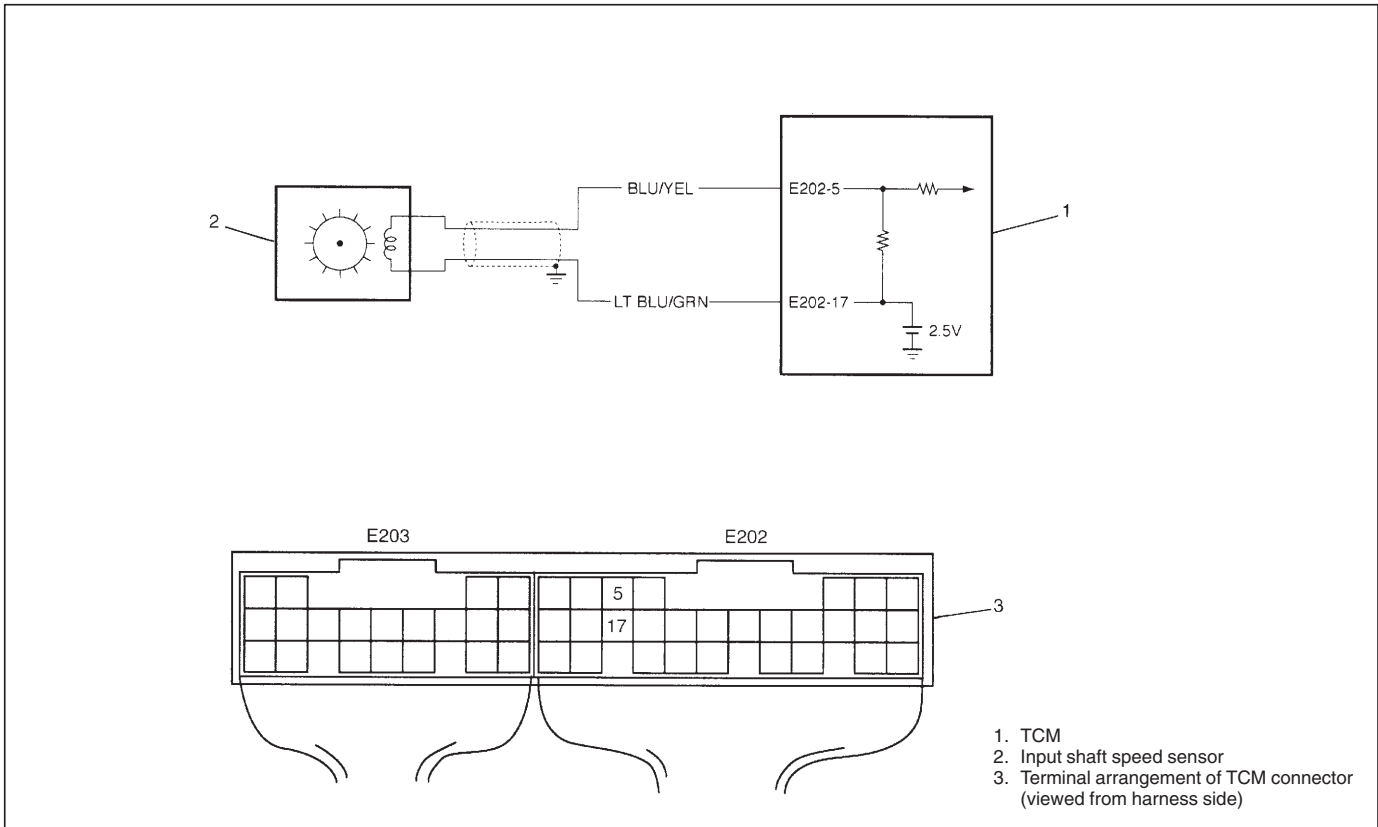

DTC DETECTING CONDITION AND TROUBLE AREA

DTC DETECTING CONDITION	TROUBLE AREA
<p>The following condition is detected for one minute continuously in the period between ignition switch ON and OFF.</p> <ul style="list-style-type: none"> ● No pulse signal out of input shaft speed sensor is inputted although 12 pulses out of output shaft speed sensor are inputted. and ● Transmission range sensor signal is detected as “D”, “2” or “L” range. and ● Gear position is not 4th. and ● Output shaft revolution is more than 775 rpm. 	<p>Input shaft speed sensor and its circuit TCM</p>

DTC CONFIRMATION PROCEDURE**WARNING:**

- When performing a road test, select a place where there is no traffic or possibility of a traffic accident and be very careful during testing to avoid occurrence of an accident.
- Road test should be carried out with 2 persons, a driver and a tester, on a level road.

- 1) Connect scan tool to DLC with ignition switch OFF.
- 2) Clear DTC by using scan tool.
- 3) Start engine and turn O/D off switch ON.
- 4) Shift select lever to D range and start vehicle.
- 5) Start vehicle and keep vehicle speed at 50 km/h (31 mile/h) with 3rd gear in D range for 60 sec. or more.
- 6) Stop vehicle.
- 7) Check DTC.

TROUBLESHOOTING

Step	Action	Yes	No
1	Was "A"/T DIAGNOSTIC FLOW TABLE" in this section performed?	Go to Step 2.	Go to "A/T DIAGNOSTIC FLOW TABLE" in this section.
2	Input shaft speed sensor circuit check: 1) With ignition switch OFF, disconnect TCM connectors. 2) Check for proper connection to input shaft speed sensor at E202-5 and E202-17 terminals. 3) If OK, check resistance of sensor circuit. Input shaft speed sensor resistance: Resistance between E202-5 and E202-17: 560 – 680 Ω (at 20°C (68°F)) Resistance between E202-5/E202-17 and ground: 1 MΩ or more Are check results satisfactory?	Go to Step 4.	Go to Step 3.
3	Input shaft speed sensor check: 1) With ignition switch OFF, disconnect input shaft speed sensor connector. 2) Check for proper connection to input shaft speed sensor at each terminals. 3) If OK, then check resistance of input shaft speed sensor. Are measured values as specified in Step 2?	"BLU/YEL" or "LT BLU/GRN" wire open or shorted to ground.	Replace input shaft speed sensor.
4	Check visually input speed shaft sensor and overdrive clutch drum for the followings. ● No damage ● No foreign material attached ● Correct installation Are they in good condition?	Intermittent trouble or faulty TCM. Check for intermittent referring to "INTERMITTENT AND POOR CONNECTION" in Section 0A. If OK, substitute a known-good TCM and recheck.	Clean, repair or replace.

REFERENCE

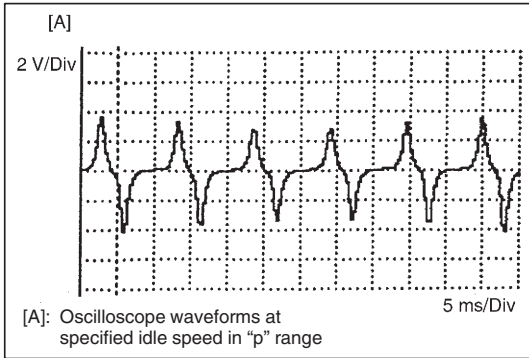

Connect oscilloscope between E202-5 (+) and E202-17 (-) of TCM connector connected to TCM and check input shaft speed sensor signal.

DTC P0720 (DTC NO.31) OUTPUT SPEED SENSOR CIRCUIT MALFUNCTION WIRING DIAGRAM

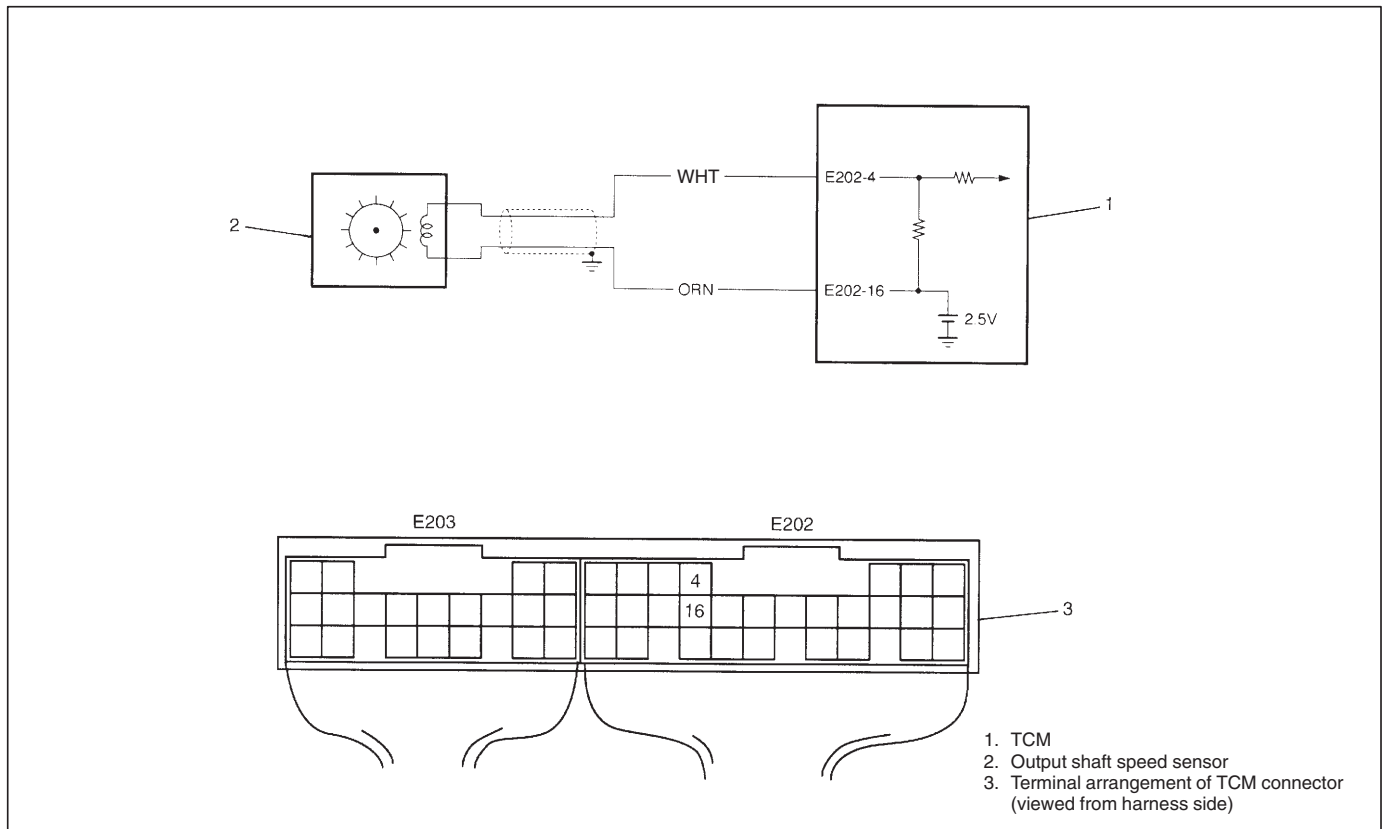

DTC DETECTING CONDITION AND TROUBLE AREA

DTC DETECTING CONDITION	TROUBLE AREA
<p>[When gear position is 1st, 2nd or 3rd gear] The following condition is detected for one minute continuously in the period between ignition switch ON and OFF.</p> <ul style="list-style-type: none"> ● No pulse signal out of output shaft speed sensor is inputted although 20 pulses out of input shaft speed sensor are inputted. and ● Transmission range sensor signal is detected as “D”, “2” or “L” range. and ● Vehicle speed is more than 5 km/h (3 mile). <p>[When gear position is 4th gear]</p> <ul style="list-style-type: none"> ● Detected (calculated) output shaft revolution is 0 rpm and 1500 rpm or more less than last detected (calculated) revolution. and ● Transmission range sensor signal is detected as “D”, “2” or “L” range. and ● Vehicle speed is more than 5 km/h (3 mile). 	<ul style="list-style-type: none"> ● Output shaft speed sensor or its circuit ● TCM

DTC CONFIRMATION PROCEDURE**WARNING:**

- When performing a road test, select a place where there is no traffic or possibility of a traffic accident and be very careful during testing to avoid occurrence of an accident.
- Road test should be carried out with 2 persons, a driver and a tester, on a level road.

- 1) Connect scan tool to DLC with ignition switch OFF.
- 2) Clear DTC in TCM memory by using scan tool.
- 3) Start engine and shift transfer lever to "2H" or "4H" range.
- 4) Drive vehicle at 50 km/h (31 mile/h) or more with 3rd gear in "D" range for longer than 60 sec. and 60 km/h (38 mile/h) or more with 4th gear for about 10 sec.
- 5) Stop vehicle and check DTC by using scan tool.

TROUBLESHOOTING

Step	Action	Yes	No
1	Was "A/T DIAGNOSTIC FLOW TABLE" in this section performed?	Go to Step 2.	Go to "A/T DIAGNOSTIC FLOW TABLE" in this section.
2	Output shaft speed sensor circuit check: 1) Remove TCM cover. 2) With ignition switch OFF, disconnect TCM connectors. 3) Check for proper connection to output shaft speed sensor at E202-4 and E202-16 terminals. 4) If OK, check resistance of sensor circuit. Resistance between E202-4 and E202-16: 387 – 473 Ω (at 20°C (68°F)) Resistance between E202-4/E202-16 and ground: 1 MΩ or more Are check results satisfactory?	Go to Step 4.	Go to Step 3.
3	Output shaft speed sensor check: 1) With ignition switch OFF, disconnect output shaft speed sensor connector. 2) Check for proper connection to output shaft speed sensor at each terminals. 3) If OK, then check resistance of output shaft speed sensor. Are measured values as specified in Step 2?	"ORN" or "WHT" wire open or shorted to ground.	Replace output shaft speed sensor.
4	Check visually output shaft speed sensor and sensor rotor for the followings. ● No damage ● No foreign material attached ● Correct installation Are they in good condition?	Intermittent trouble or faulty TCM. Check for intermittent referring to "INTERMITTENT AND POOR CONNECTION" in Section 0A. If OK, substitute a known-good TCM and recheck.	Clean, repair or replace.

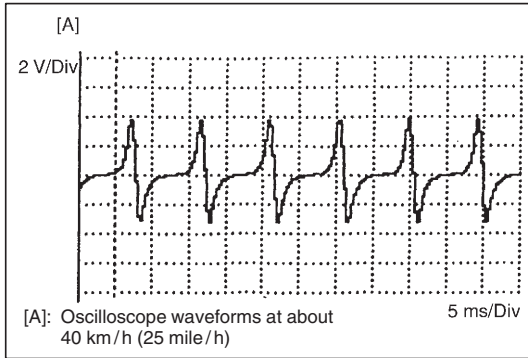
REFERENCE

Connect oscilloscope between E202-4 (+) and E202-16 (-) of TCM connector connected to TCM and check output shaft speed sensor signal.

DTC P0725 (DTC NO.35) ENGINE SPEED INPUT CIRCUIT MALFUNCTION WIRING DIAGRAM

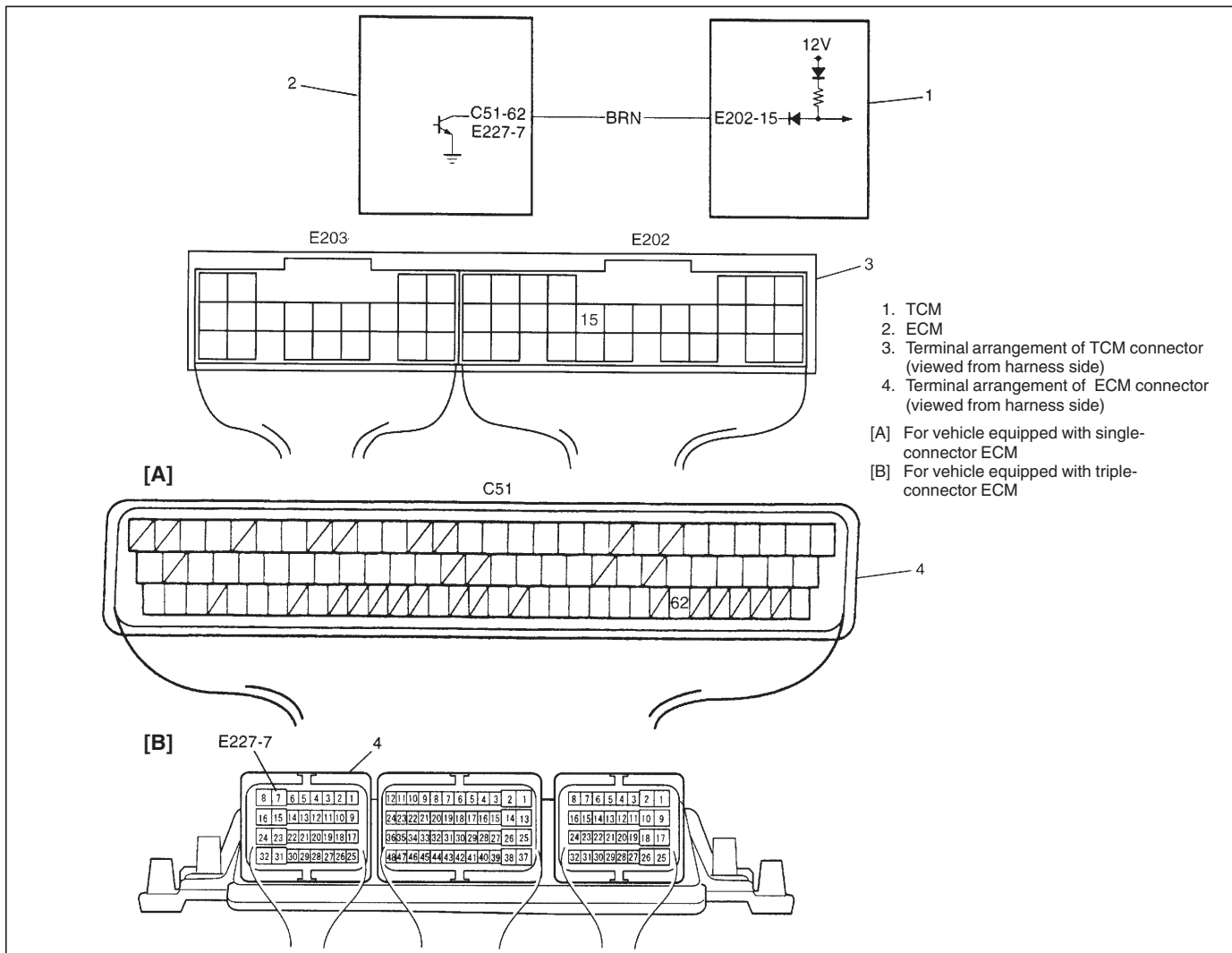

DTC DETECTING CONDITION AND TROUBLE AREA

DTC DETECTING CONDITION	TROUBLE AREA
No engine speed signal is inputted although input shaft speed sensor signals indicate 2000 rpm or more.	<ul style="list-style-type: none"> ● Engine speed input circuit ● TCM ● ECM

DTC CONFIRMATION PROCEDURE

WARNING

- When performing a road test, select a place where there is no traffic or possibility of a traffic accident and be very careful during testing to avoid occurrence of an accident.
- Road test should be carried out with 2 persons, a driver and tester, on a level road.

- 1) Connect scan tool to DLC with ignition switch OFF.
- 2) Clear DTC in TCM memory by using scan tool.
- 3) Start engine and shift turn O/D off switch OFF.
- 4) Shift selector lever in "D" range and drive vehicle with keeping vehicle speed about 65 km/h (41 mile/h) at 3rd gear for 10 second.
- 5) Stop vehicle and check DTC by using scan tool.

TROUBLESHOOTING

Step	Action	Yes	No
1	Was "A/T DIAGNOSTIC FLOW TABLE" in this section performed?	Go to Step 2.	Go to "A/T DIAGNOSTIC FLOW TABLE" in this section.
2	<p>Check engine speed input circuit.</p> <p>1) Turn ignition switch OFF and disconnect TCM and ECM connectors.</p> <p>2) Check for proper connection to TCM and ECM at following terminals. For vehicle equipped with single-connector ECM: E202-15 and C51-62. For vehicle equipped with triple-connector ECM: E202-15 and E227-7.</p> <p>3) If OK, measure resistance between terminal E202-15 of disconnected harnesses side TCM connector and following terminal. For vehicle equipped with single-connector ECM: terminal C51-62 of disconnected harness side ECM connector. For vehicle equipped with triple-connector ECM: terminal E227-7 of disconnected harness side ECM connector.</p> <p>Is it about 0 Ω?</p>	Go to Step 3.	"BRN" circuit open.
3	<p>Check engine speed input circuit.</p> <p>Measure between terminal E202-15 of disconnected harness side TCM connector and ground.</p> <p>Is it infinity?</p>	Go to Step 4.	"BRN" circuit shorted to ground.
4	<p>Check TCM terminal voltage.</p> <p>1) With ignition switch OFF, connect TCM connector.</p> <p>2) Turn ignition switch ON.</p> <p>3) Measure voltage between following terminal and ground. For vehicle equipped with single-connector ECM: terminal C51-62 of disconnected harness side ECM connector. For vehicle equipped with triple-connector ECM: terminal E227-7 of disconnected harness side ECM connector.</p> <p>Is it 10 – 14 V?</p>	<p>Intermittent trouble, faulty TCM or faulty ECM.</p> <p>Check for intermittent referring to "INTERMITTENT AND POOR CONNECTION" in Section 0A.</p> <p>If OK, substitute a known-good TCM or ECM and recheck.</p>	Substitute a known-good TCM and recheck.

DTC P0743 (DTC NO.25/26) TCC (LOCK-UP) SYSTEM ELECTRICAL WIRING DIAGRAM

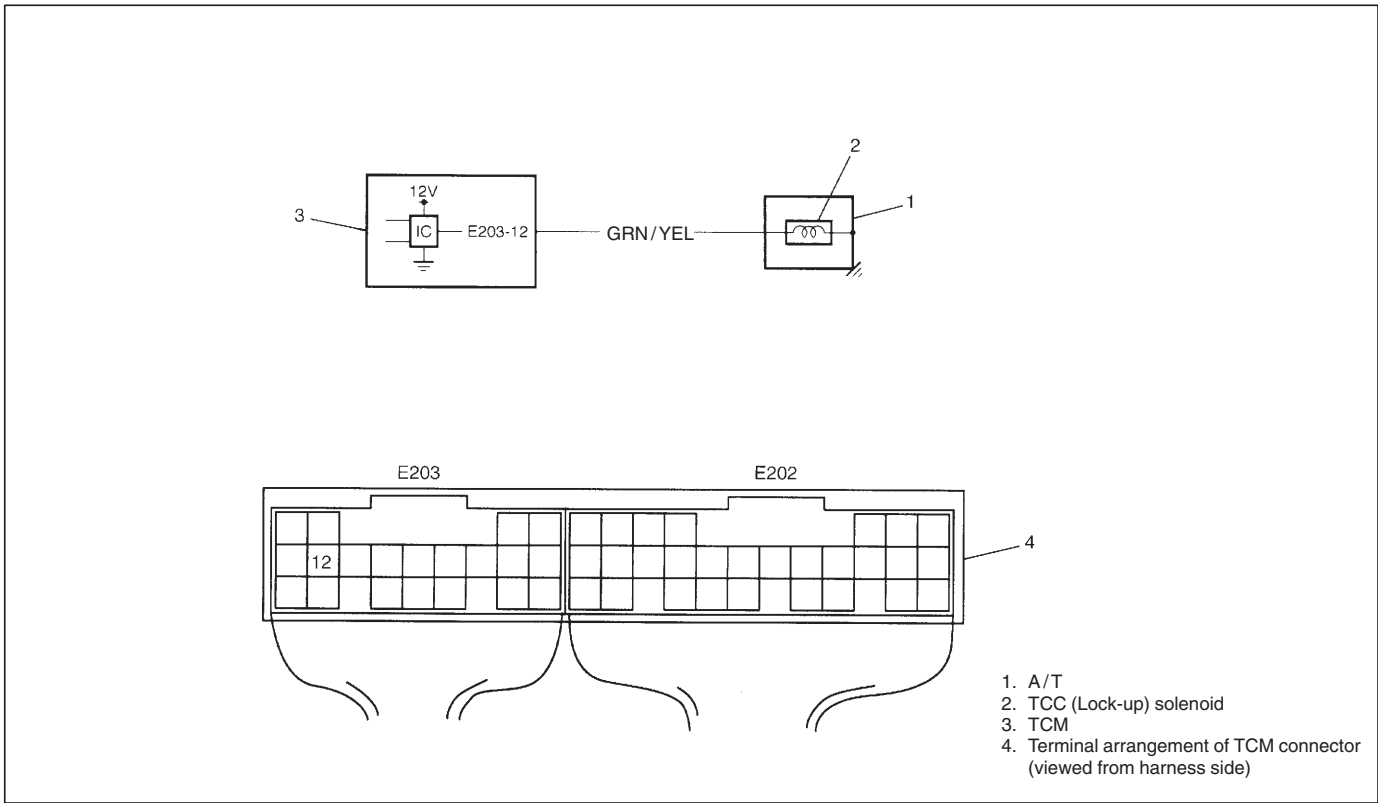

DTC DETECTING CONDITION AND TROUBLE AREA

DTC DETECTING CONDITION	TROUBLE AREA
<p>The following condition is detected 8 times of gear change continuously.</p> <ul style="list-style-type: none"> ● Voltage at terminal E203-12 of TCM is too high while TCC solenoid OFF is commanded or too low while TCC solenoid ON is commanded. 	<ul style="list-style-type: none"> ● TCC (lock-up) solenoid valve ● TCC (lock-up) solenoid valve circuit ● TCM

DTC CONFIRMATION PROCEDURE**WARNING:**

- When performing a road test, select a place where there is no traffic or possibility of a traffic accident and be very careful during testing to avoid occurrence of an accident.
- Road test should be carried out with 2 persons, a driver and a tester, on a level road.

- 1) Connect scan tool to DLC with ignition switch OFF.
- 2) Clear DTC in TCM memory by using scan tool.
- 3) Start engine, warm it up to normal operating temperature and shift transfer lever to “2H” or “4H” range.
- 4) Shift selector lever in D range and start vehicle.
- 5) Increase vehicle speed to about 80 km/h (50 mile/h) in 4th gear and in D range.
- 6) Release accelerator pedal, decrease vehicle speed and stop vehicle.
- 7) Repeat step 4) to step 6) one time.
- 8) Check DTC by using scan tool.

TROUBLESHOOTING

Step	Action	Yes	No
1	Was “A/T DIAGNOSTIC FLOW TABLE” in this section performed?	Go to Step 2.	Go to “A/T DIAGNOSTIC FLOW TABLE” in this section.
2	Check TCC solenoid circuit for short. 1) Turn ignition switch OFF and disconnect TCM connectors. 2) Check for proper connection to TCM at terminal E203-12. 3) If OK, then turn ignition switch ON and measure voltage between terminal E203-12 of disconnected TCM harness side connector and ground. Is it about 0 V?	Go to Step 3.	“GRN/ORN” circuit shorted to power circuit.
3	Check TCC solenoid circuit for open or short. 1) Turn ignition switch OFF. 2) Measure resistance between terminal E203-12 of disconnected TCM harness side connector and ground. Is it 11 – 15 Ω (at 20°C (68°F))?	Intermittent trouble or faulty TCM. Check for intermittent referring to “INTERMITTENT AND POOR CONNECTION” in Section 0A. If OK, substitute a known-good TCM and recheck.	“GRN/ORN” circuit open or shorted to ground. If wire and connections are OK, replace TCC solenoid.

DTC P0748 (DTC NO.41/42) PRESSURE CONTROL SOLENOID ELECTRICAL WIRING DIAGRAM

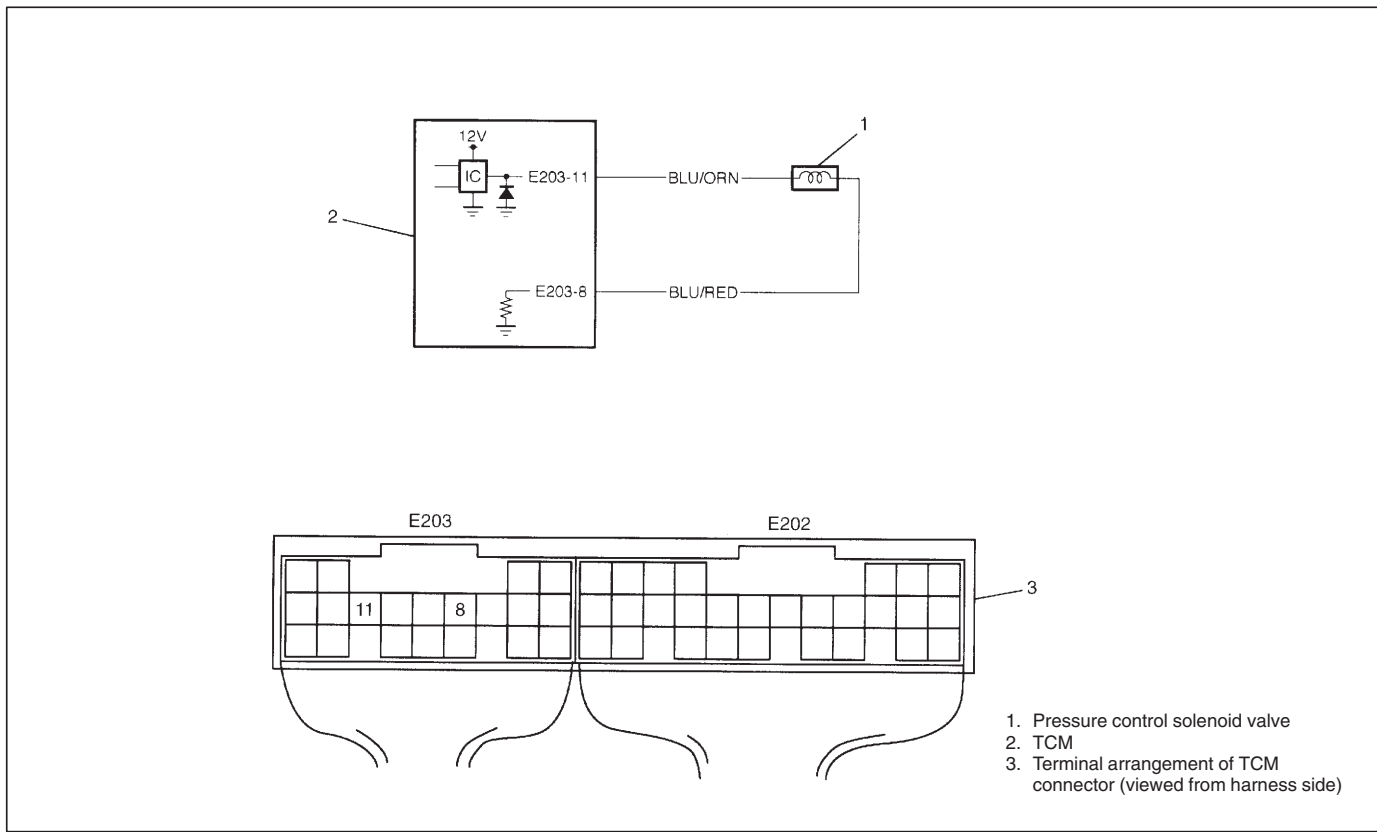

DTC DETECTING CONDITION AND TROUBLE AREA

DTC DETECTING CONDITION	TROUBLE AREA
<ul style="list-style-type: none"> ● Pressure control solenoid output voltage is too high comparing with TCM command value. or ● Pressure control solenoid output voltage is too low comparing with TCM command value. 	<ul style="list-style-type: none"> ● Pressure control solenoid valve ● Pressure control solenoid valve circuit ● TCM

DTC CONFIRMATION PROCEDURE

WARNING

- When performing a road test, select a place where there is no traffic or possibility of a traffic accident and be very careful during testing to avoid occurrence of an accident.
- Road test should be carried out with 2 persons, a driver and tester, on a level road.

- 1) Connect scan tool to DLC with ignition switch OFF.
- 2) Clear DTC in TCM memory by using scan tool.
- 3) Start engine and shift selector lever in "D" range.
- 4) Start vehicle and increase vehicle speed to about 60 km/h at "D" range.
- 5) Keep driving above vehicle speed for 30 second.
- 6) Stop vehicle and check DTC by using scan tool.

TROUBLESHOOTING

Step	Action	Yes	No
1	Was "A/T DIAGNOSTIC FLOW TABLE" in this section performed?	Go to Step 2.	Go to "A/T DIAGNOSTIC FLOW TABLE" in this section.
2	Check pressure control solenoid circuit for short. 1) Turn ignition switch OFF and disconnect TCM connectors. 2) Check for proper connection to TCM at terminal E203-11 and E203-8. 3) If OK, measure voltage between terminal E203-8 of disconnected harness side TCM connectors and ground. Is it about 0 V?	Go to Step 3.	"BLU/ORN" or "BLU/RED" circuit shorted to power circuit.
3	Check pressure control solenoid circuit for short. Measure resistance between terminal E203-11 or disconnected harness side TCM connector and ground. Is it infinity?	Go to Step 4.	"BLU/ORN" or "BLU/RED" circuit shorted to ground.
4	Check pressure control solenoid circuit for short. Measure resistance between terminal E203-8 and E203-11 of disconnected harness side TCM connector. Is it 5.0 – 5.6 Ω (20°C (68°F))?	Intermittent trouble or faulty TCM. Check for intermittent referring to "INTERMITTENT AND POOR CONNECTION" in Section 0A. If OK, substitute a known-good TCM and recheck.	Faulty pressure control solenoid valve. Replace valve body assembly.

DTC P0753 (DTC NO.21/22)/ SHIFT SOLENOID-A/SHIFT SOLENOID-B P0758 (DTC NO.23/24) ELECTRICAL

WIRING DIAGRAM

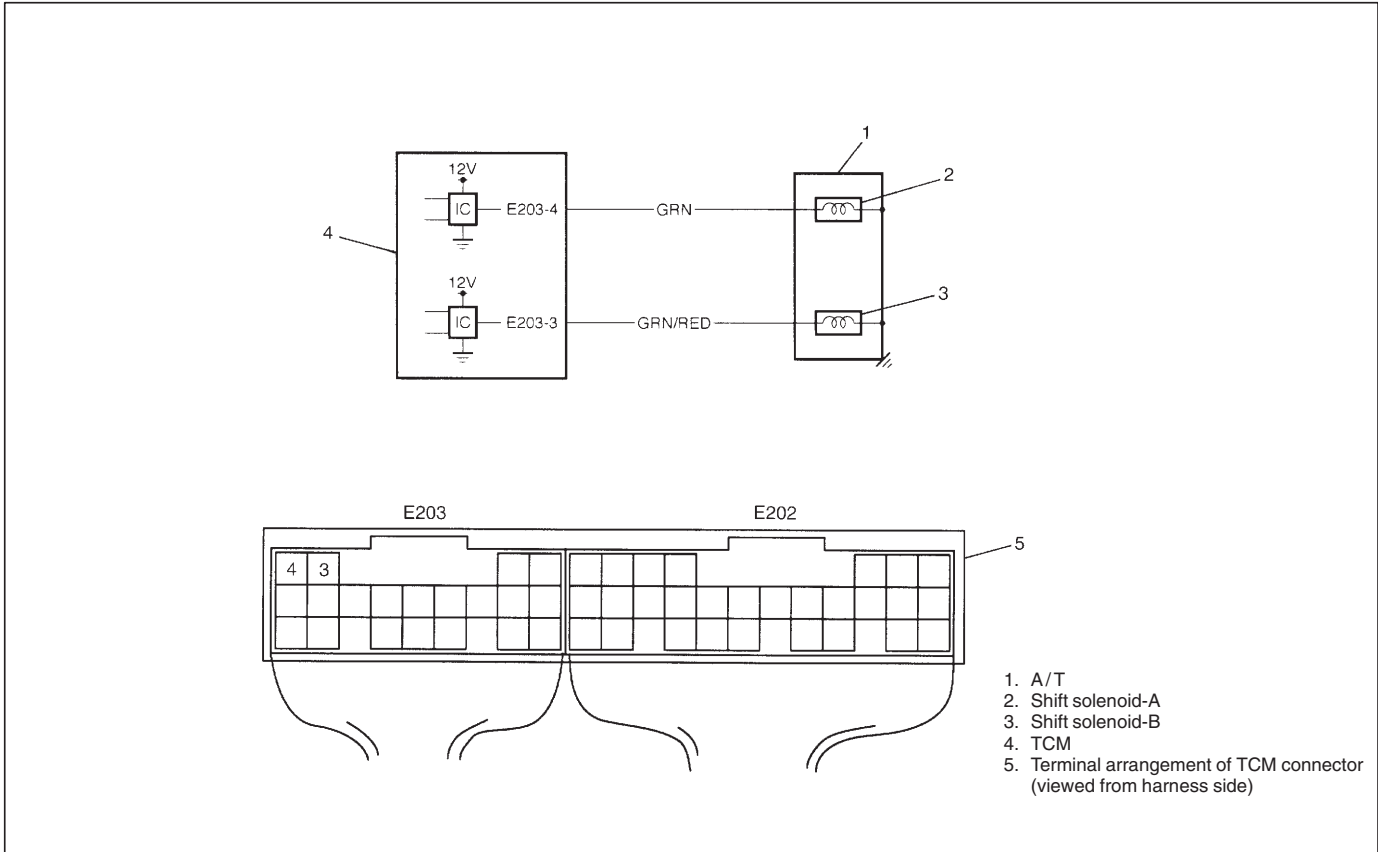

DTC DETECTING CONDITION AND TROUBLE AREA

DTC DETECTING CONDITION	TROUBLE AREA
<p>DTC P0753: The following condition is detected 8 times of gear change continuously.</p> <ul style="list-style-type: none"> ● Voltage at terminal E203-4 of TCM is too high while shift solenoid OFF is commanded or too low while shift solenoid ON is commanded 	<ul style="list-style-type: none"> ● Shift solenoid valve-A ● Shift solenoid valve-A circuit ● TCM
<p>DTC P0758: The following condition is detected 8 times of gear change continuously.</p> <ul style="list-style-type: none"> ● Voltage at terminal E203-3 of TCM is too high while shift solenoid OFF is commanded or too low while shift solenoid ON is commanded 	<ul style="list-style-type: none"> ● Shift solenoid valve-B ● Shift solenoid valve-B circuit ● TCM

DTC CONFIRMATION PROCEDURE**WARNING:**

- When performing a road test, select a place where there is no traffic or possibility of a traffic accident and be very careful during testing to avoid occurrence of an accident.
- Road test should be carried out with 2 persons, a driver and a tester, on a level road.

- 1) Connect scan tool to DLC with ignition switch OFF.
- 2) Clear DTC in TCM memory by using scan tool.
- 3) Start engine and shift transfer lever to “2H” or “4H” range.
- 4) Shift selector lever in D range and start vehicle.
- 5) Increase vehicle speed to about 80 km/h (50 mile/h) with 4th gear in D range.
- 6) Release accelerator pedal, decrease vehicle speed and stop vehicle.
- 7) Repeat step 4) to step 6) five times.
- 8) Check DTC by using scan tool.

TROUBLESHOOTING

Step	Action	Yes	No
1	Was “A/T DIAGNOSTIC FLOW TABLE” in this section performed?	Go to Step 2.	Go to “A/T DIAGNOSTIC FLOW TABLE” in this section.
2	Check shift solenoid circuit for short. 1) Turn ignition switch OFF and disconnect TCM connectors. 2) Check for proper connection to TCM at terminals E202-3 or E203-4. 3) If OK, then turn ignition switch ON and measure voltage between terminal E203-3 or E203-4 of disconnected harness side TCM connector and ground. Is it about 0 V?	Go to Step 3.	“GRN” or “GRN/RED” circuit shorted to power circuit.
3	Check shift solenoid circuit for open or short. 1) Turn ignition switch OFF. 2) Measure resistance between terminal E203-3 or E203-4 of disconnected harness side TCM connector and ground. Is it 11 – 15 Ω (at 20°C (68°F))?	Intermittent trouble or faulty TCM. Check for intermittent referring to “INTERMITTENT AND POOR CONNECTION” in Section 0A. If OK, substitute a known-good TCM and recheck.	“GRN” or “GRN/RED” circuit open or shorted to ground. If wire and connections are OK, replace malfunction shift solenoid.

DTC P1700 (DTC NO.32/33) ACCELERATION STROKE SIGNAL INPUT MALFUNCTION

WIRING DIAGRAM

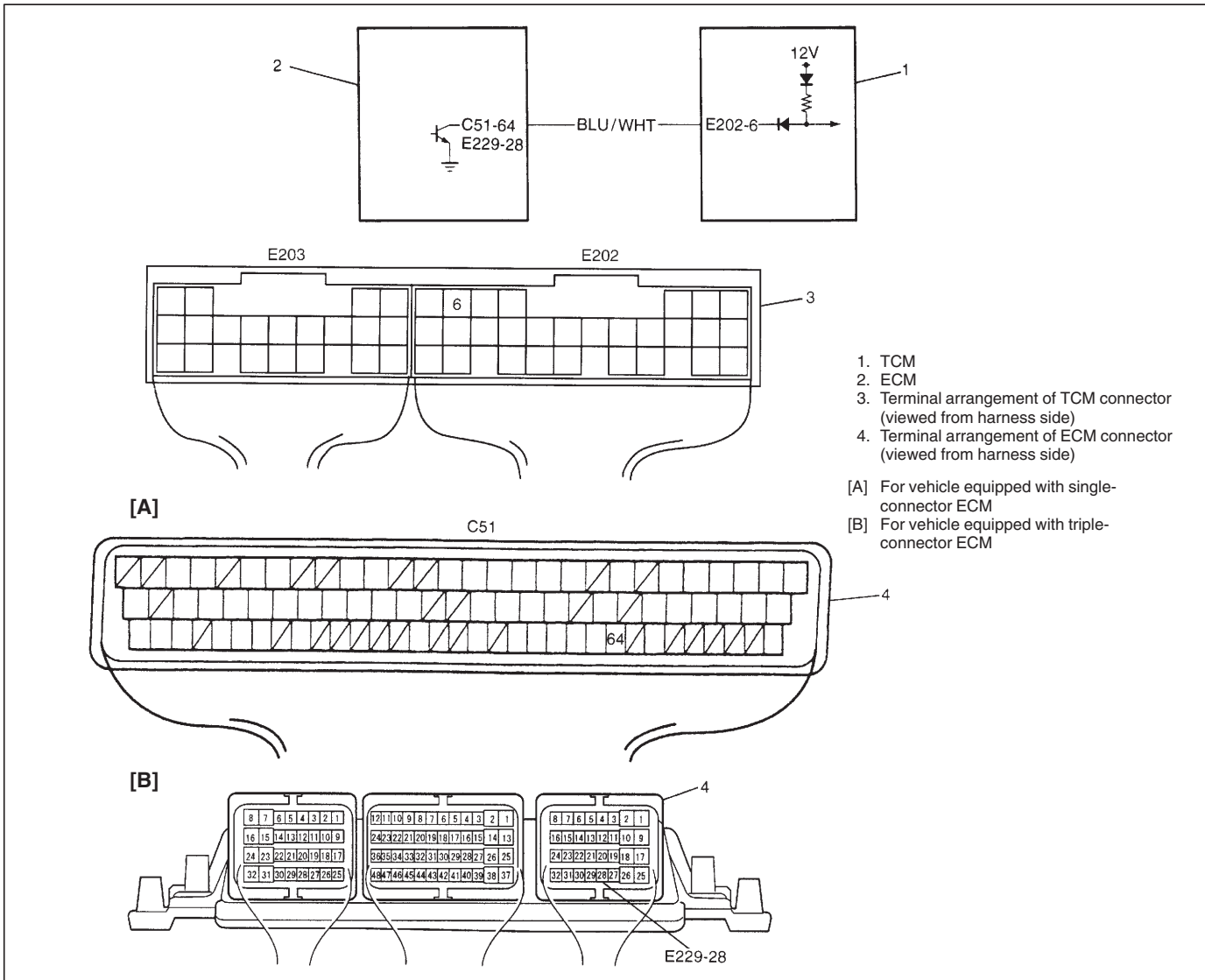

DTC DETECTING CONDITION AND TROUBLE AREA

DTC DETECTING CONDITION	TROUBLE AREA
<ul style="list-style-type: none"> • Continuous time of low voltage acceleration stroke signal is too long. or • Continuous time of low voltage acceleration stroke signal is too short. 	<ul style="list-style-type: none"> • Acceleration stroke signal circuit • TCM • ECM

DTC CONFIRMATION PROCEDURE

- 1) Connect scan tool to DLC with ignition switch OFF.
- 2) Clear DTC in TCM memory by using scan tool.
- 3) Start engine and keep on idling for 20 seconds.
- 4) Stop engine and check DTC by using scan tool.

TROUBLESHOOTING

Step	Action	Yes	No
1	Was "A/T DIAGNOSTIC FLOW TABLE" in this section performed?	Go to Step 2.	Go to "A/T DIAGNOSTIC FLOW TABLE" in this section.
2	<p>Check acceleration stroke signal input circuit for open.</p> <p>1) Turn ignition switch OFF and disconnect TCM and ECM connectors.</p> <p>2) Check for proper connection to TCM and ECM at following terminals. For vehicle equipped with single-connector ECM: E202-6 and C51-64. For vehicle equipped with triple-connector ECM: E202-6 and E229-28.</p> <p>3) If OK, measure resistance between terminal E202-6 of disconnected harnesses side TCM connector and following terminal. For vehicle equipped with single-connector ECM : terminal C51-64 of disconnected harness side ECM connector. For vehicle equipped with triple-connector ECM: terminal E229-28 of disconnected harness side ECM connector.</p> <p>Is it about 0 Ω?</p>	Go to Step 3.	"BLU/WHT" circuit open.
3	<p>Check acceleration stroke signal input circuit for short.</p> <p>Measure between terminal E202-6 of disconnected harness side TCM connector and ground.</p> <p>Is it infinity?</p>	Go to Step 4.	"BLU/WHT" circuit shorted to ground.
4	<p>Check acceleration stroke signal input circuit for short to power circuit.</p> <p>1) With ignition switch OFF, connect ECM connector.</p> <p>2) Turn ignition switch ON.</p> <p>3) Measure voltage between terminal E202-6 of disconnected harness side TCM connector and ground.</p> <p>Is it about 0 V?</p>	Go to Step 5.	"BLU/WHT" circuit shorted to power circuit.
5	<p>Check TCM terminal voltage.</p> <p>1) With ignition switch OFF, connect TCM connector and disconnect ECM connector.</p> <p>2) Turn ignition switch ON.</p> <p>3) Measure voltage between following terminal and ground. For vehicle equipped with single-connector ECM: terminal C51-64 of disconnected harness side ECM connector. For vehicle equipped with triple-connector ECM: terminal E229-28 of disconnected harness side ECM connector.</p> <p>Is it 10 – 14 V?</p>	<p>Intermittent trouble, faulty TCM or faulty ECM.</p> <p>Check for intermittent referring to "INTERMITTENT AND POOR CONNECTION" in Section 0A.</p> <p>If OK, substitute a known-good TCM or ECM and recheck.</p>	Substitute a known-good TCM and recheck.

DTC P1702 (DTC NO.52) INTERNAL MALFUNCTION OF TCM

DTC DETECTING CONDITION	TROUBLE AREA
Calculations of current data stored in TCM is not correct comparing with pre-stored checking data in TCM.	<ul style="list-style-type: none"> ● TCM

DTC CONFIRMATION PROCEDURE

- 1) Connect scan tool to DLC with ignition switch OFF.
- 2) Clear DTC in TCM memory by using scan tool.
- 3) Turn ignition switch ON, and OFF.
- 4) Check DTC by using scan tool.

TROUBLESHOOTING

Step	Action	Yes	No
1	Is DTC P1702 outputted after performing DTC confirmation procedure?	Faulty TCM	Could be a temporary malfunction of TCM.

DTC P1730 (DTC NO.64) ENGINE TORQUE SIGNAL CIRCUIT MALFUNCTION WIRING DIAGRAM

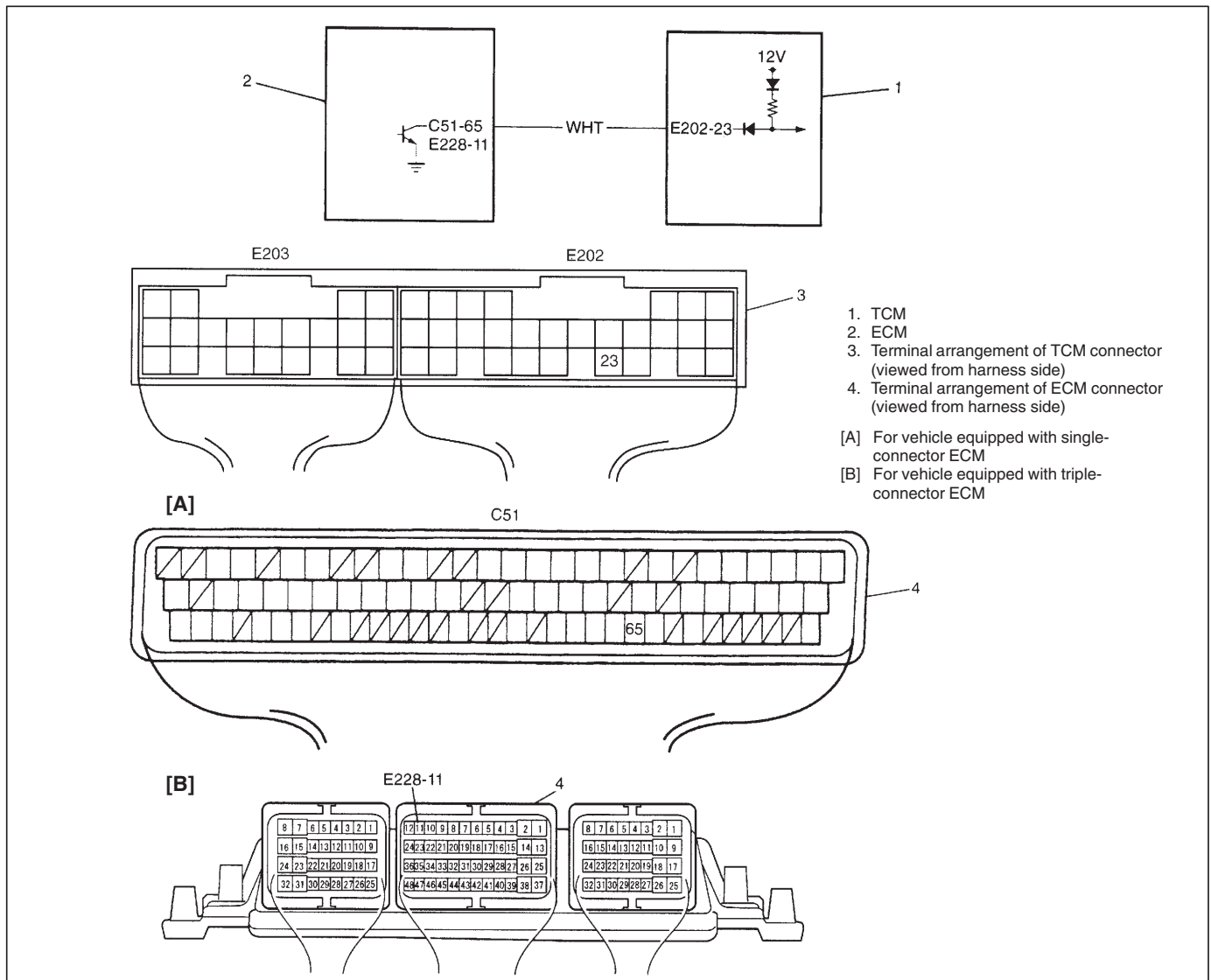

DTC DETECTING CONDITION AND TROUBLE AREA

DTC DETECTING CONDITION	TROUBLE AREA
<ul style="list-style-type: none"> • Continuous time of low voltage engine torque signal is too long. or • Continuous time of low voltage engine torque signal is too short. 	<ul style="list-style-type: none"> • Engine torque signal circuit • TCM • ECM

DTC CONFIRMATION PROCEDURE

- 1) Connect scan tool to DLC with ignition switch OFF.
- 2) Clear DTC in TCM memory by using scan tool.
- 3) Start engine and keep on idling for 10 seconds.
- 4) Stop engine and check DTC by using scan tool.

TROUBLESHOOTING

Step	Action	Yes	No
1	Was "A/T DIAGNOSTIC FLOW TABLE" in this section performed?	Go to Step 2.	Go to "A/T DIAGNOSTIC FLOW TABLE" in this section.
2	<p>Check engine torque signal circuit for open.</p> <p>1) Turn ignition switch OFF and disconnect TCM and ECM connectors.</p> <p>2) Check for proper connection to TCM and ECM at following terminals. For vehicle equipped with single-connector ECM: E202-23 and C51-65. For vehicle equipped with triple-connector ECM: E202-23 and E228-11.</p> <p>3) If OK, measure resistance between terminal E202-23 of disconnected harnesses side TCM connector and following terminal. For vehicle equipped with single-connector ECM: terminal C51-65 of disconnected harness side ECM connector. For vehicle equipped with triple-connector ECM: terminal E228-11 of disconnected harness side ECM connector.</p> <p>Is it about 0 Ω?</p>	Go to Step 3.	"WHT" circuit open.
3	<p>Check engine torque signal circuit for short. Measure between terminal E202-23 of disconnected harness side TCM connector and ground.</p> <p>Is it infinity?</p>	Go to Step 4.	"WHT" circuit shorted to ground.
4	<p>Check engine torque signal circuit for short to power circuit.</p> <p>1) With ignition switch OFF, connect ECM connector to ECM.</p> <p>2) Turn ignition switch ON.</p> <p>3) Measure voltage between terminal E202-23 of disconnected harness side TCM connector and ground.</p> <p>Is it about 0 V?</p>	Go to Step 5.	"WHT" circuit shorted to power circuit.
5	<p>Check TCM terminal voltage.</p> <p>1) With ignition switch OFF, connect TCM connector and disconnect ECM connector.</p> <p>2) Turn ignition switch ON.</p> <p>3) Measure voltage between following terminal and ground. For vehicle equipped with single-connector ECM: terminal C51-65 of disconnected harness side ECM connector. For vehicle equipped with triple-connector ECM: terminal E228-11 of disconnected harness side ECM connector.</p> <p>Is it 10 – 14 V?</p>	<p>Intermittent trouble, faulty TCM or faulty ECM.</p> <p>Check for intermittent referring to "INTERMITTENT AND POOR CONNECTION" in Section 0A.</p> <p>If OK, substitute a known-good TCM or ECM and recheck.</p>	Substitute a known-good TCM and recheck.

ON-VEHICLE SERVICE

MAINTENANCE SERVICE

FLUID LEVEL

LEVEL CHECK AT NORMAL OPERATING TEMPERATURE

- 1) Stop vehicle and place it level.
- 2) Apply parking brake and place chocks against wheels.
- 3) With selector at P position, start engine.
- 4) Warm up engine till fluid temperature reaches normal operating temperature (70–80°C (158–176°F)). As a guide to check fluid temperature, warm up engine till engine coolant temperature meter indicated around 1 unit above “C” point.

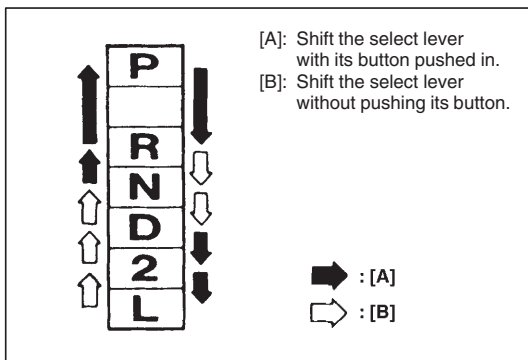

- 5) Keep engine idling and shift selector slowly to “L” and back to “P” position.

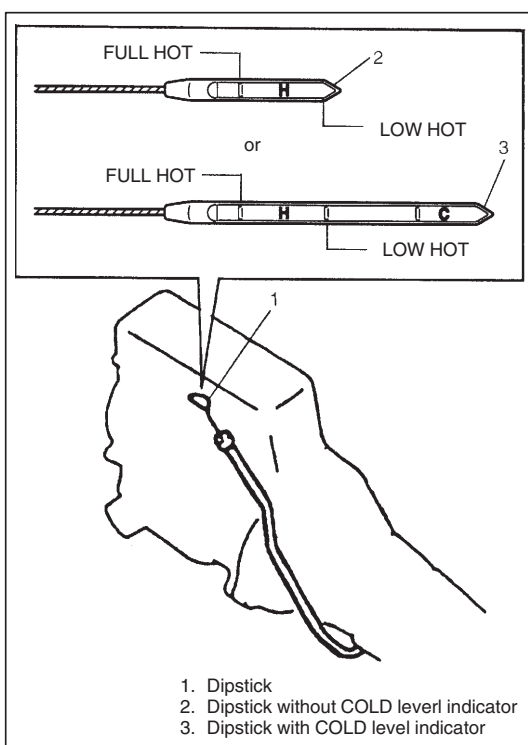

- 6) With engine idling, pull out dipstick (1), wipe it off with a clean cloth and put it back into place.
- 7) Pull out dipstick (1) again and check fluid level indicated on it. Fluid level should be between FULL HOT and LOW HOT. If it is below LOW HOT, add an equivalent of DEXRON®-III up to FULL HOT.

Fluid specification:

An equivalent of DEXRON®-III

NOTE:

- **DO NOT RACE ENGINE** while checking fluid level, even after the engine start.
- **DO NOT OVERFILL.** Overfilling can cause foaming and loss of fluid through breather. Then slippage and transmission failure can result.
- Bringing the level from LOW HOT to FULL HOT requires 0.3 liters (0.64/0.53 US/Imp.pt).
- If vehicle was driven under high load such as pulling a trailer, fluid level should be checked about half an hour after it is stopped.

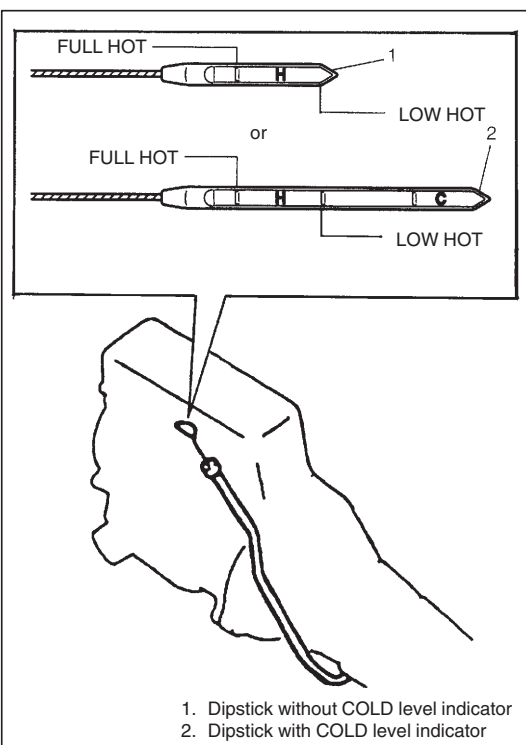
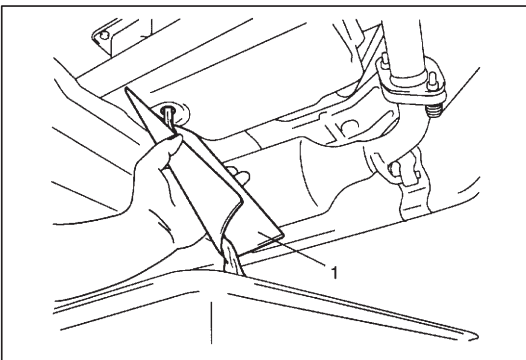
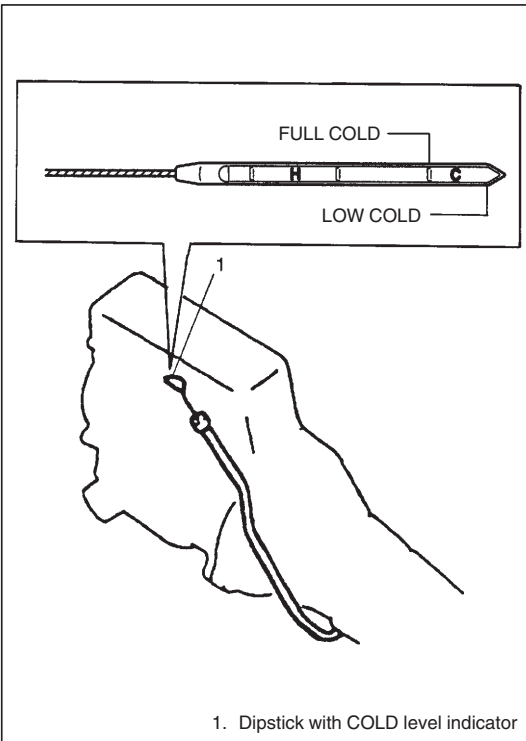

LEVEL CHECK AT ROOM TEMPERATURE

[For vehicle with dipstick with COLD level indicator]

The fluid level check at room temperature performed after repair or fluid change before test driving is just preparation for level check of normal operating temperature. The checking procedure itself is the same as that described previously. If the fluid level is between FULL COLD and LOW COLD, proceed to test drive. And when the fluid temperature has reached the normal operating temperature, check fluid level again and adjust it as necessary.

FLUID CHANGE

- 1) Lift up vehicle.
- 2) With engine is cool, remove drain plug from oil pan and drain A/T fluid using oil gutter (1).
- 3) Install drain plug (1).

Tightening torque

A/T fluid drain plug: 20 N·m (2.0 kg·m, 14.5 lb-ft)

- 4) Lower vehicle and fill proper amount of an equivalent of DEXRON®-III.
- 5) Check fluid level referring to “LEVEL CHECK NORMAL OPERATING TEMPERATURE” of “FLUID LEVEL” in this section.

Fluid specification:

An equivalent of DEXRON®-III

Fluid capacity

When draining from drain plug hole:

2.2 liters (4.65/3.87 US/Imp.pt.)

When overhauling:

7.8 liters (16.48/13.73 US/Imp.pt.)

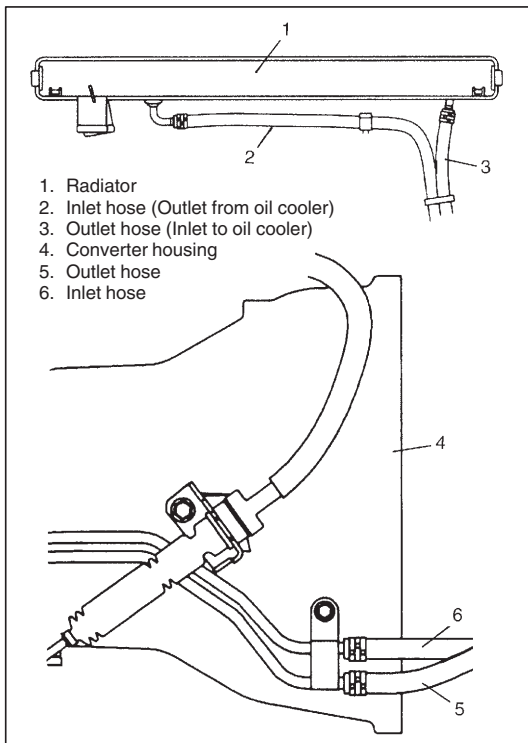

OIL COOLER HOSES

When replacing them, be sure to note the followings.

- to replace clamps at the same time
- to insert hose as far as bulge of pipe
- to clamp hose securely

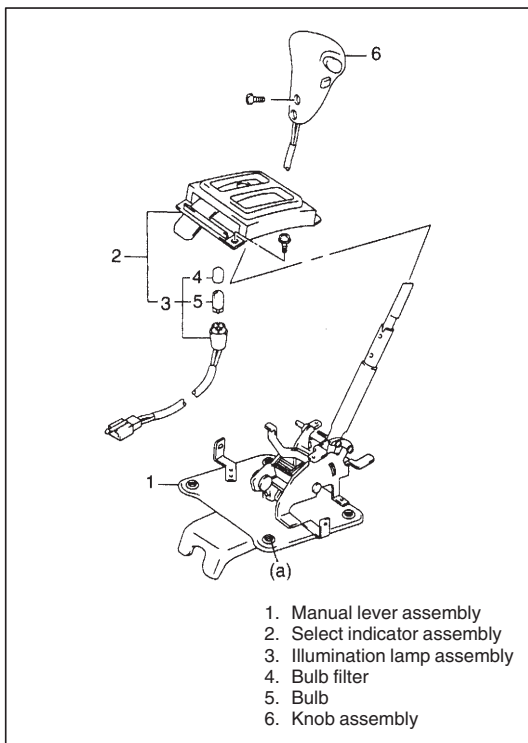

MANUAL SELECTOR ASSEMBLY

Tightening torque

Manual selector assembly bolts (a):
 18 N·m (1.8 kg-m, 13.5 lb-ft)

REMOVAL

- 1) Disconnect negative cable at battery.
- 2) Remove console box.
- 3) Disconnect connector for illumination lamp and O/D off switch.
- 4) Remove selector assembly mounting bolts.
- 5) Disconnect select cable from lever of selector assembly.

INSTALLATION

Reverse removal procedure to install.

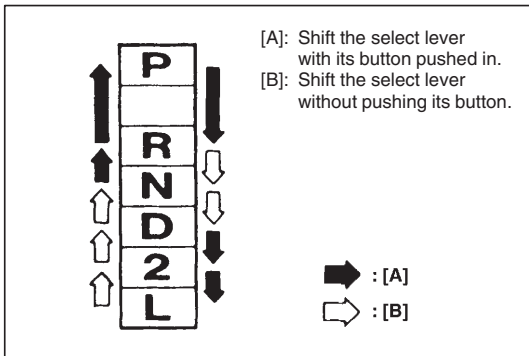

INSPECTION

Check select lever for smooth and clear-cut movement and position indicator for correct indication.

For operation of select lever, refer to the figure.

SELECT CABLE

Tightening torque

Manual select lever nut (a): 13 N·m (1.3 kg-m, 9.5 lb-ft)

Manual select cable end nut (b): 7 N·m (0.7 kg-m, 5.5 lb-ft)

Transmission range sensor lock bolt (c):

5.5 N·m (0.55 kg-m, 4.0 lb-ft)

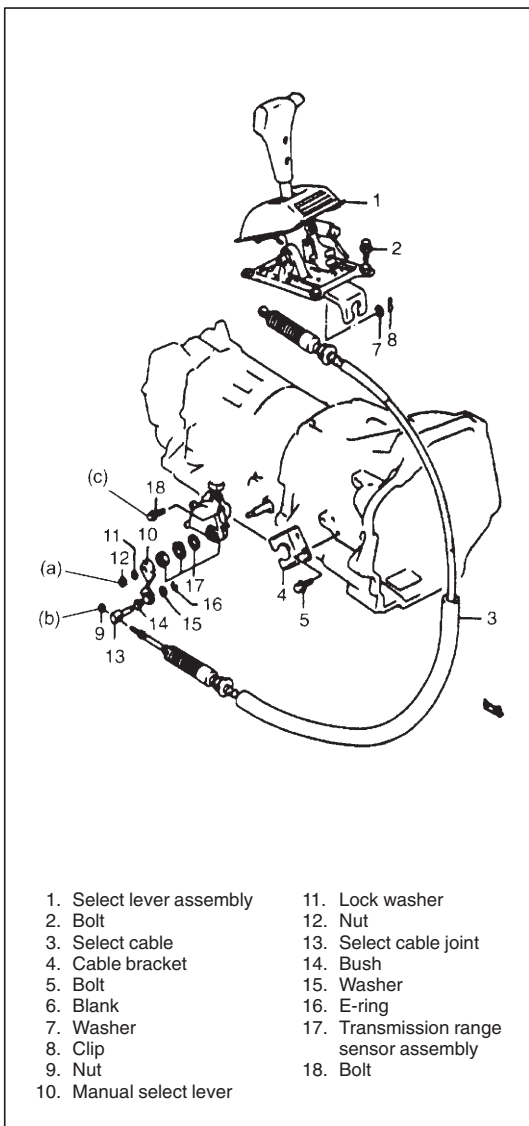

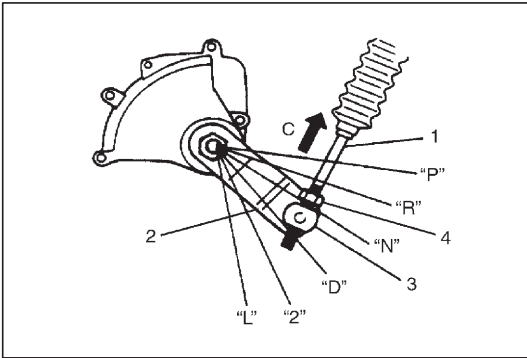

ADJUSTMENT

- 1) Before tightening cable end nut (4), shift select lever to "N".
- 2) Also shift manual shift lever (2) to "N".

NOTE:

- Make sure that nut (4) and cable joint (3) have clearance under above conditions.
- If select cable (1) has been moved, push it in arrow C direction as shown in figure at the left till it stops and then confirm that select lever is in "N" position.

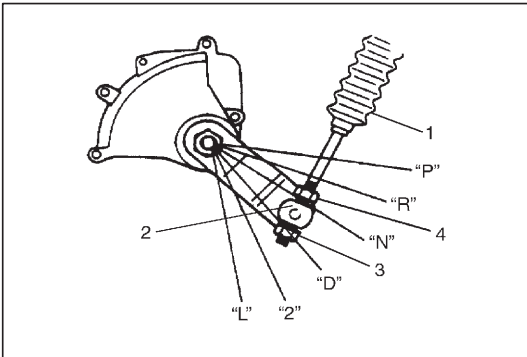

- 3) Turn nut (3) by hand till it contacts manual select cable joint (2). Then tighten nut (4) with wrench.
- 4) After select cable (1) was installed, check for the following.
 - Push vehicle with select lever shifted to "P". Vehicle should not move.
 - Vehicle can not be driven in "N".
 - Vehicle can be driven in "D", "2", and "L".
 - Vehicle can be backed in "R".

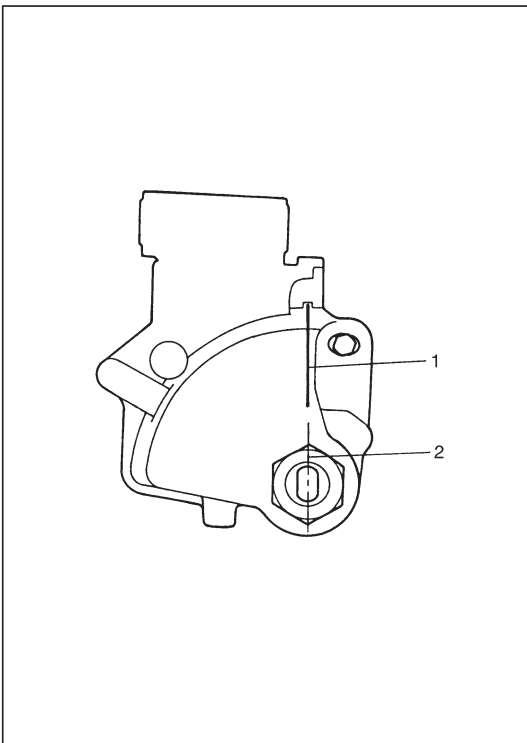

TRANSMISSION RANGE SWITCH

INSPECTION AND ADJUSTMENT

- 1) Shift select lever to "N" range.
- 2) Check that center line on manual valve shaft (2) and "N" reference line (1) on switch are aligned. If not, loosen switch bolt and align them.
- 3) Check that engine starts in "N" and "P" ranges but it doesn't start in "D", "2", "L" or "R" range. Also, check that back-up lamp lights in "R" range.

If faulty condition cannot be corrected by adjustment, disconnect transmission range switch coupler and check that continuity exists as shown by moving select lever.

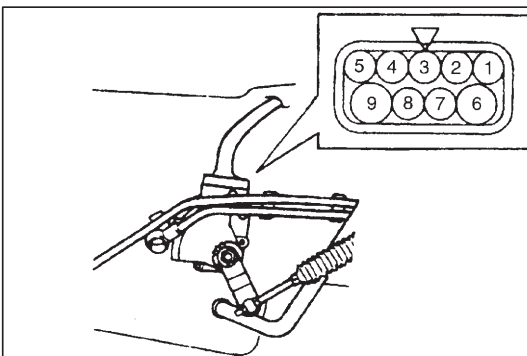

		Terminal No.								
		1	2	3	4	5	6	7	8	9
Switch position	P	○	—	○			○	—	○	
	R		○	—	○					
	N			○	—	○	○	—	○	
	D			○	—	○	○	—	○	
	2			○	—	○				
	L			○	—	○	○	—	○	

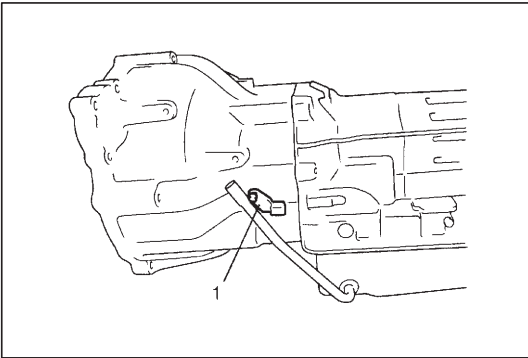

INPUT SHAFT SPEED SENSOR

INSPECTION

Check input shaft speed sensor (1) for resistance between terminals of sensor or TCM connector.

Input shaft speed sensor resistance:
560 – 680 Ω (at 20°C (68°F))

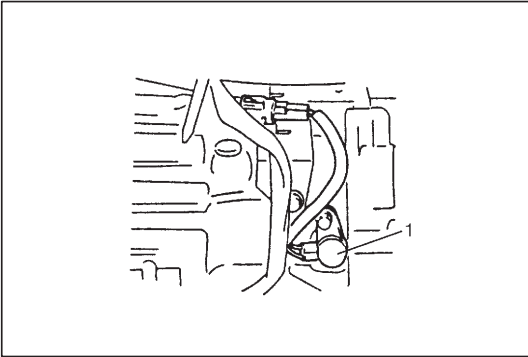

OUTPUT SHAFT SPEED SENSOR

INSPECTION

Check output shaft speed sensor (1) for resistance between terminals of sensor or TCM connector.

Output shaft speed sensor resistance:
387 – 473 Ω (at 20°C (68°F))

O/D OFF SWITCH

INSPECTION

Check O/D off switch for operation referring to step 4 of “DIAGNOSTIC FLOW TABLE B-2” in this section.

If malfunction is found, replace.

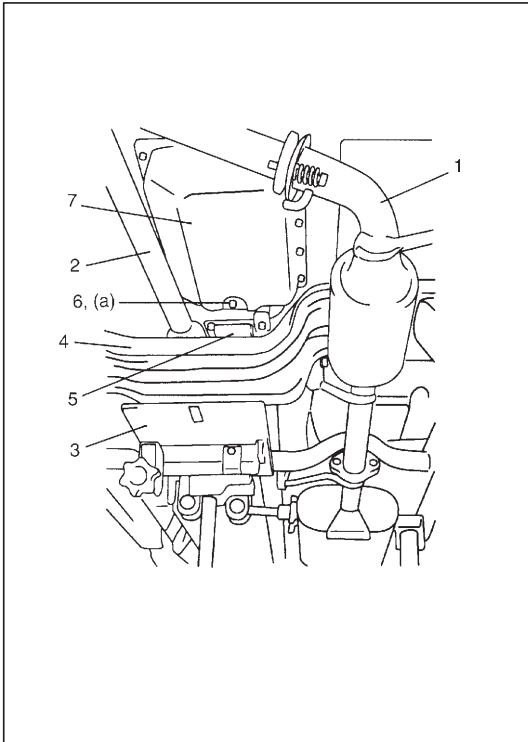

SOLENOID VALVES (SHIFT SOLENOID VALVES, TCC SOLENOID VALVE AND PRESSURE CONTROL SOLENOID VALVE)

REMOVAL

- 1) Disconnect negative cable from battery.
- 2) Pull out fluid level gauge and lift up vehicle.
- 3) Remove exhaust No.2 pipe (1).
- 4) Disconnect front propeller shaft (2) from front differential.
- 5) Apply transmission jack (3) and take off rear mounting member (4).
- 6) Remove engine rear mounting (5).
- 7) Remove drain plug (6) and Drain A/T fluid.
- 8) Install drain plug (6).

Tightening torque

A/T fluid drain plug (a) : 20 N·m (2.0 kg-m, 14.5 lb-ft)

- 9) Remove A/T oil pan (7).

- 10) Disconnect shift solenoid-A valve, shift solenoid-B valve, TCC solenoid valve and pressure control solenoid valve connector referring to "UNIT REPAIR" in this section.
- 11) Remove shift solenoid-A valve, shift solenoid-B valve, TCC solenoid valve and pressure control solenoid valve referring to "UNIT REPAIR" in this section.

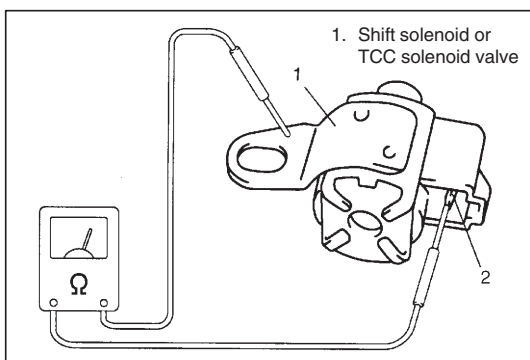

SOLENOID VALVES (SHIFT SOLENOID VALVES AND TCC SOLENOID VALVE)

INSPECTION

Resistance Check

Measure resistance between terminal (2) and solenoid valve body.

Shift solenoid valve and TCC solenoid valve resistance

Standard: 11 – 15 Ω (at 20°C (68°F))

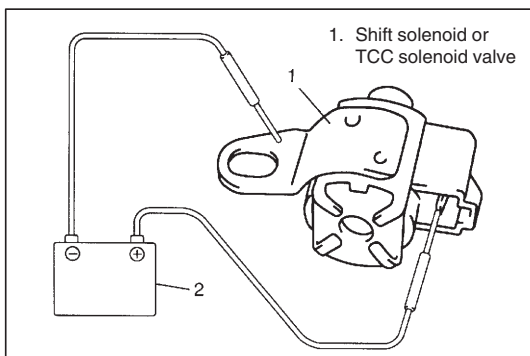

Operation Check

- When solenoid is connected to battery (2) as shown in the figure, check that solenoid valve actuate with click sound.

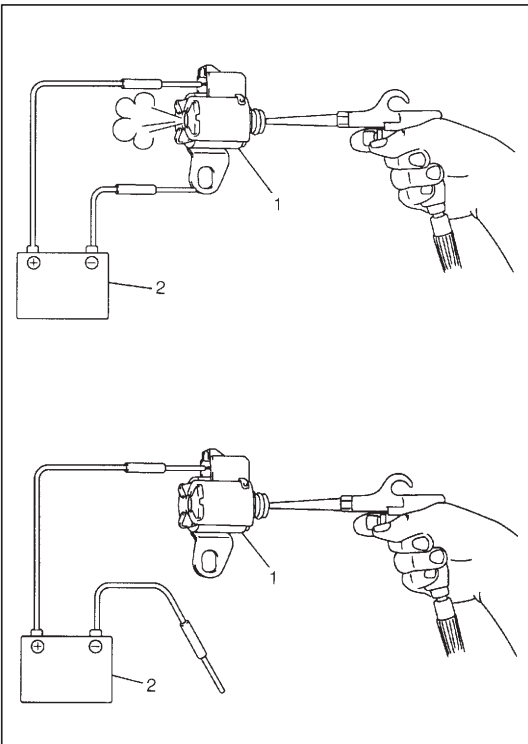

- When shift solenoid valve (1) is connected to battery (2), confirm that shift solenoid valve is open condition by blowing air (50 – 200 kpa, 0.5 – 2.0 kg/cm², 7 – 28.5 psi) into solenoid valve as shown in the figure.
- When shift solenoid valve (1) is not connected to battery (2), confirm that shift solenoid valve is close condition by blowing air (50 – 200 kpa, 0.5 – 2.0 kg/cm², 7 – 28.5 psi) into solenoid valve as shown in the figure.

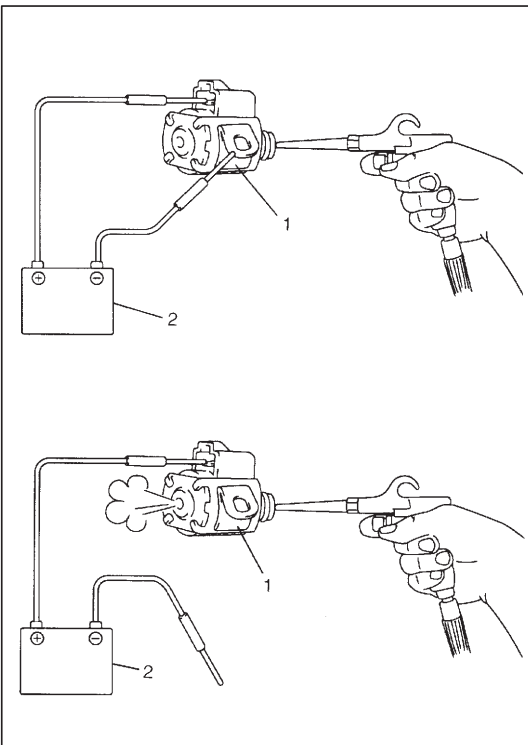

- When TCC solenoid valve (1) is connected to battery (2), confirm that shift solenoid valve is close condition by blowing air (50 – 200 kpa, 0.5 – 2.0 kg/cm², 7 – 28.5 psi) into solenoid valve as shown in the figure.
- When TCC solenoid valve (1) is not connected to battery (2), confirm that TCC solenoid valve is open condition by blowing air (50 – 200 kpa, 0.5 – 2.0 kg/cm², 7 – 28.5 psi) into solenoid valve as shown in the figure.

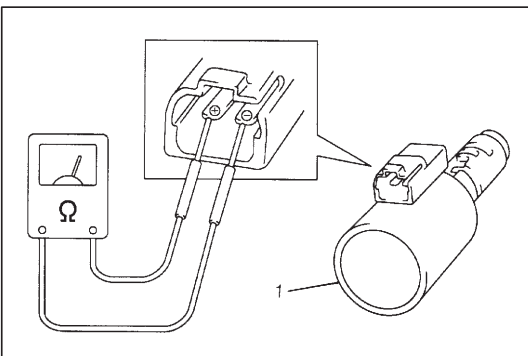

PRESSURE CONTROL SOLENOID VALVE INSPECTION

Resistance Check

Measure resistance between pressure control solenoid valve (1) terminals.

Pressure control solenoid valve resistance
Standard: 5.0 – 5.6 Ω (at 20°C (68°F))

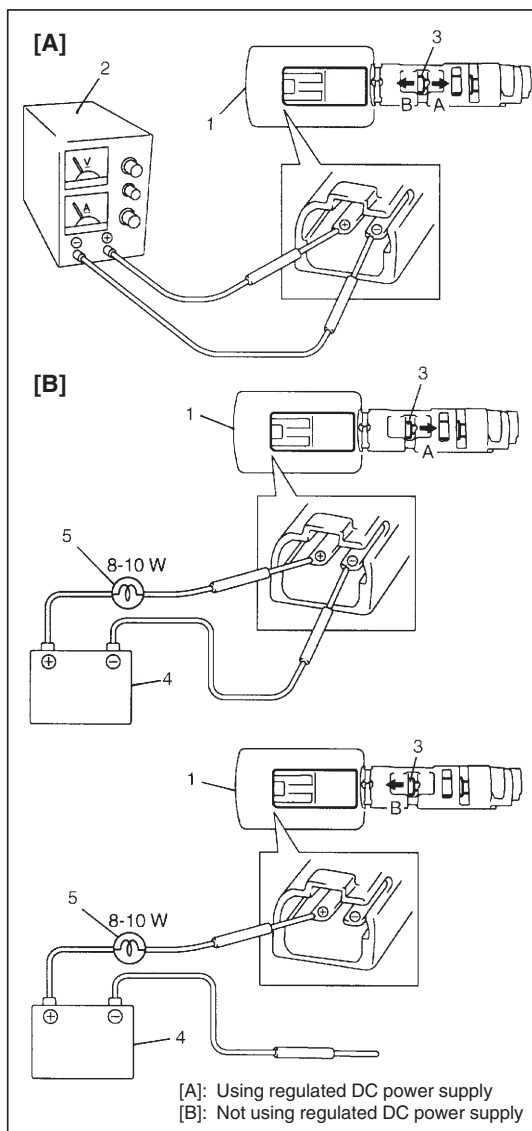

Operation Check

Check pressure control solenoid valve (1) operation in the either manner of the followings.

[Using regulated DC power supply]

- 1) Connect pressure control solenoid valve (1) with regulated DC power supply (2) as shown in the figure.
- 2) Turn regulated DC power supply switch ON, increase voltage of power supply keeping current within 1.0 A.
- 3) Check for gradual movement of valve (3) in the direction of arrow "A" as increase voltage.
- 4) Check movement of valve (3) in the direction of arrow "B" as decrease voltage.
- 5) Turn power supply switch OFF.

CAUTION:

Do not pass current 1.0 A or more, or pressure control solenoid is burned out.

[Not using regulated DC power supply]

- 1) Connect pressure control solenoid valve (1) to battery (4) setting the 8 – 10 W bulb (5) on the way as shown in the figure.
- 2) Check for movement of valve (3) in the direction of arrow "A".
- 3) Disconnect pressure control solenoid valve (1) from battery (4) and check movement of valve (3) in the direction of arrow "B" as shown in the figure.

CAUTION:

Set 8 – 10 W bulb on the way, or pressure control solenoid valve is burned out.

INSTALLATION

Reverse removal procedure to install solenoid valves and noting the following points.

- For details of solenoid valves and their connectors installation, refer to "UNIT REPAIR" in this section. Use new O-ring.
- For details of A/T oil pan installation, refer to "UNIT REPAIR" in this section. Use new oil pan gasket.
- Tighten Universal joint flange bolts & nuts, engine rear mounting bolts, exhaust pipe bolts & nuts and rear mount member bolts.
- Fill A/T fluid and check fluid level according to procedure described in "CHANGING FLUID" of "MAINTENANCE SERVICE" in this section.
- Check for fluid leakage after warming up A/T.

ACCELERATION STROKE SENSOR

INSPECTION

Refer to Section 6E3 for inspection.

TRANSMISSION CONTROL MODULE (TCM)

CAUTION:

TCM consists of highly precise parts, so when handling it , be careful not to expose to excessive shock.

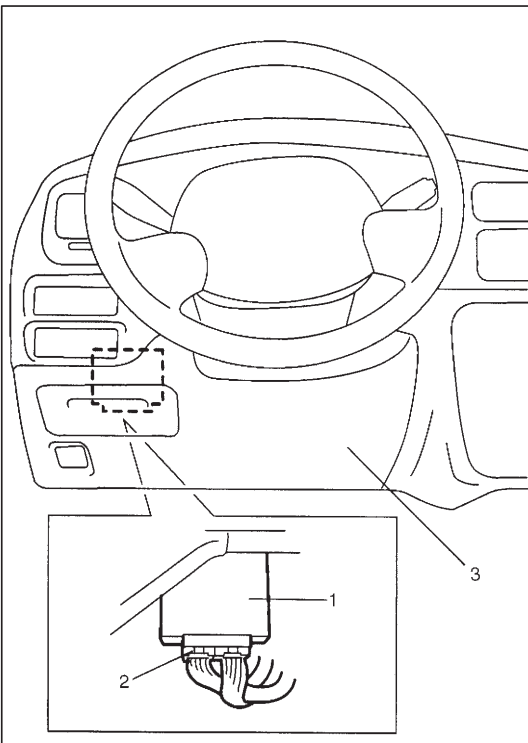

REMOVAL

- 1) Disconnect negative cable at battery.
- 2) If vehicle is equipped with air bag system, disable air bag system.
Refer to "DISABLING AIR BAG SYSTEM" in Section 10B.
- 3) Remove steering column hole cover (3).
- 4) Disconnect couplers (2) from TCM (1).
- 5) Loosen bolt and remove TCM (1).

INSTALLATION

Reverse removal procedure noting the following.

- Connect TCM couplers securely.
- If vehicle is equipped with air bag system, be sure to enable air bag system after TCM are back in place. Refer to "ENABLING AIR BAG SYSTEM" in Section 10B.



4WD LOW SWITCH

INSPECTION

- 1) Disconnect negative cable (–) at battery.
- 2) Disconnect 4WD LOW switch coupler (2).
- 3) Check continuity between 4WD LOW switch (1) terminals.
There should be continuity when transfer lever shifted to 4L position and should be infinity when transfer lever shifted to 4H or 2H positions.
If not, replace 4WD LOW switch (1).
- 4) Connect 4WD LOW switch coupler (2) and battery negative (–) cable.

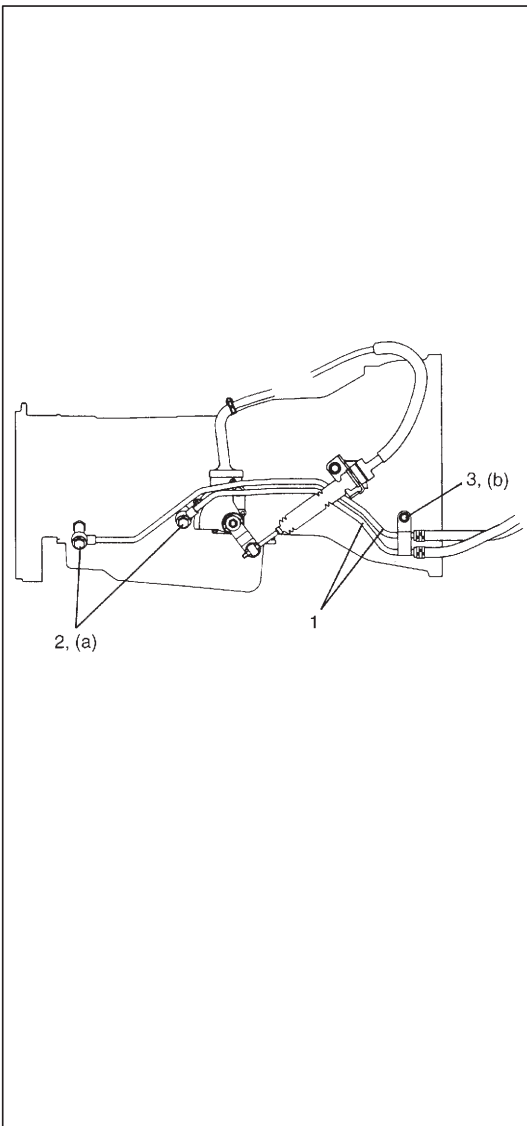

OIL COOLER PIPES

REMOVAL

- 1) Lift up vehicle.
- 2) Make sure to wash dirt off from around pipe joints.
- 3) With engine is cool, loosen oil cooler pipe union bolts with oil outlet union locked and remove oil cooler pipes (1) from oil outlet unions and hoses.

NOTE:

To avoid fluid leakage, plug open ends of oil outlet unions and hoses right after they are disconnected.

INSTALLATION

- 1) Use new union gaskets and connect oil cooler pipes to oil outlet unions.
- 2) Connect hoses to pipes and clamp them securely.
- 3) Tighten union bolts (2) to specified torque with oil outlet union locked.

Tightening torque

Oil cooler pipe union bolts (a) (For copper gasket):

35 N·m (3.5 kg·m, 25.5 lb-ft)

Oil cooler pipe union bolts (a) (For rubber coated gasket):

25 N·m (2.5 kg·m, 18.0 lb-ft)

- 4) Tighten pipe clamp bolt (3) securely.

Tightening torque

Oil cooler pipe clamp bolt (b):

10 N·m (1.0 kg·m, 7.5 lb-ft)

- 5) Check A/T fluid level according to procedure described in "MAINTENANCE SERVICE" in this section.
- 6) Check for fluid leakage after warming up A/T.

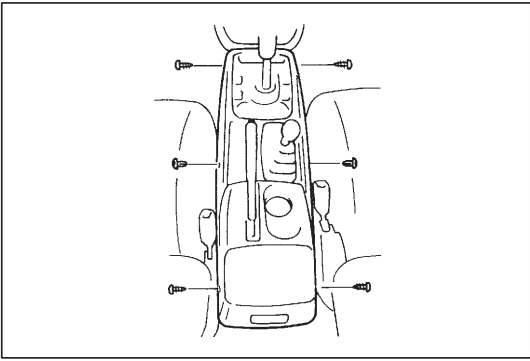

AUTOMATIC TRANSMISSION ASSEMBLY (WITH TRANSFER)

DISMOUNTING

In Cabin

- 1) Remove console box.

NOTE:

To remove clip, push in its center pin first.

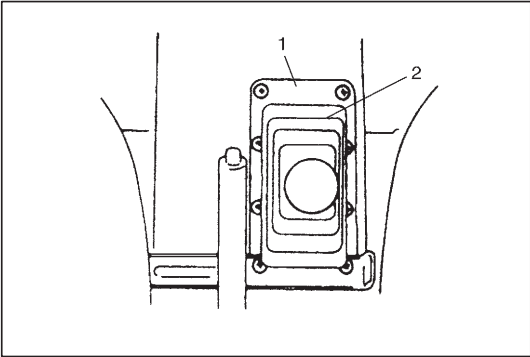

- 2) Remove boot cover (1) and boot No.2 (2).

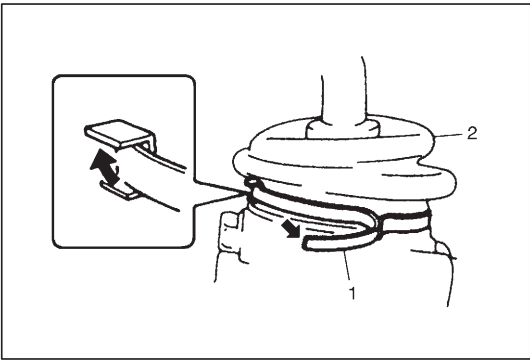

- 3) Remove boot clamp (1) and then remove boot No.1 (2) from transfer gear shift lever case.

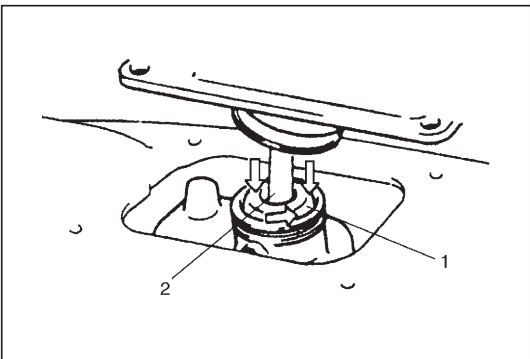

- 4) With transfer shift control case cover (1) pushed down with fingers, turn it to counterclockwise and take out shift control lever (2).

In Engine Room

- 1) Remove battery and dipstick.
- 2) Disconnect CKP sensor connector.
- 3) Remove CKP sensor mounting bolt and then remove CKP sensor from torque converter housing.
- 4) Remove starter motor. But don't disconnect its wiring harness.
- 5) Remove transmission to engine bolt.

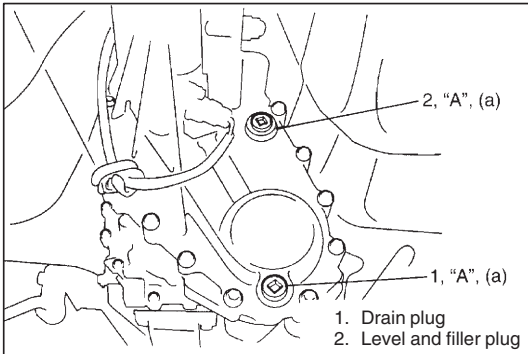
**On Lift**

- 1) Remove transfer skid plate (if equipped).
- 2) Drain transfer oil.

"A": Sealant 99000-31110

Tightening torque

**Transfer oil drain and level/filler plugs (a):
23 N·m(2.3 kg-m, 17.0 lb-ft)**

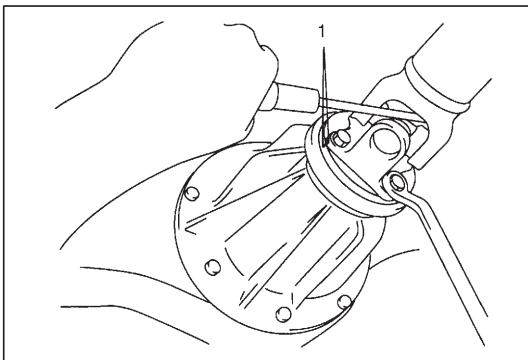

- 3) Before removing propeller shaft, give match marks (1) on joint flange and propeller shaft as shown in the figure.
- 4) Remove universal joint flange bolts and take out rear propeller shaft.
- 5) Likewise, take out front propeller shaft.
- 6) Remove nut from the end of select cable and bracket to set cable free.
- 7) Remove select cable bracket by removing its 2 bolts.
- 8) Remove exhaust No.1 and No.2 pipe.
- 9) Remove stabilizer bar mount bush bracket bolts.
- 10) Unclamp and disconnect oil cooler hoses from pipes.

NOTE:

To avoid leakage of transmission fluid, plug open ends of oil cooler pipes and hoses right after they are disconnected.

- 11) Remove torque converter housing lower plate.

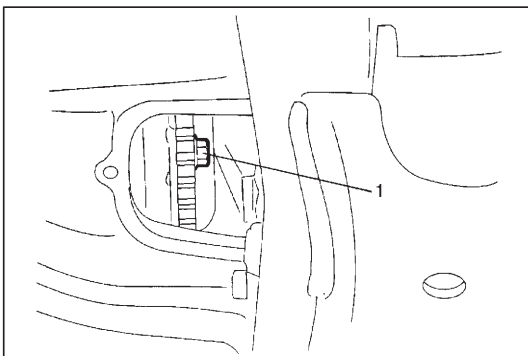

- 12) Holding crankshaft pulley bolt stationary with wrench, remove torque converter mounting bolts (1) with wrench.
- 13) Apply transmission jack (1) and take off rear mounting member by removing its bolts.

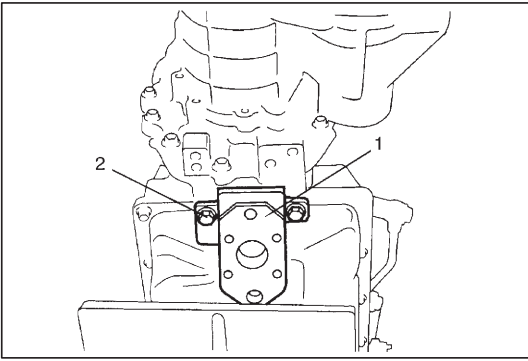

- 14) Remove rear mounting (1) by removing its bolts (2).

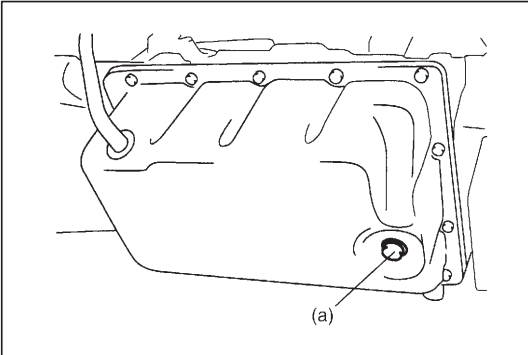
**NOTE:**

If automatic transmission is overhauled later on, draining A/T fluid at this point will facilitate work.

Tightening torque

A/T fluid drain plug (a): 20 N·m (2.0 kg-m, 14.5 lb-ft)

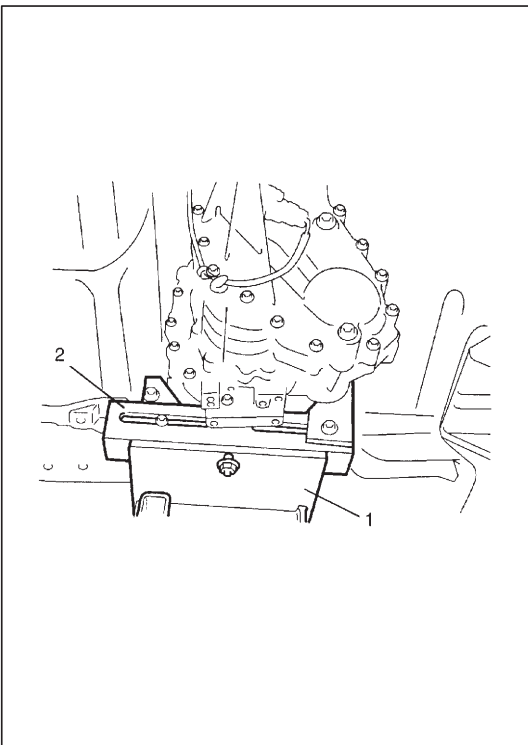

- 15) Lower the transmission jack slowly. Remove it from the transmission, then install the auxiliary arm (2) to the transmission jack (1).
- 16) Raise the transmission jack until it touches the transmission.
- 17) Disconnect connectors from VSS, output shaft speed sensor, input shaft speed sensor, transmission range sensor, shift & TCC solenoid valves and other electrical parts, and release their wire harness from clamps.
- 18) Remove breather hose and harness clamp mounting bolt from transmission.
- 19) Remove oil filler upper tube by removing its bolts.
- 20) Remove engine to transmission bolts and nuts.

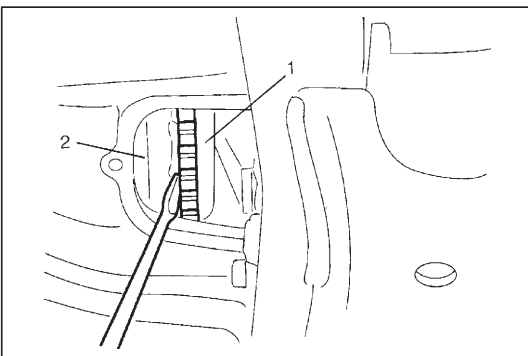

- 21) With transmission assembly held up on jack, move them to the rear and lower them including torque converter. As necessary, insert a rod into the gap between the drive plate (1) and the torque converter (2), then separate the driver plate (1) from the torque converter (2).

WARNING:

Transmission assembly may tilt rearward on jack. It is recommended to use an auxiliary arm of jack for the purpose of safety.

After Dismounting

WARNING:

Be sure to keep transmission and transfer assembly horizontal throughout the work. Should they be tilted, torque converter may fall off and cause personal injury and A/T fluid may flow out.

- 1) Remove breather hose.
- 2) Remove transfer by removing its bolts.

REMountING

WARNING:

When moving transmission assembly with torque converter equipped in it, be sure to keep it horizontal. Tilting it with its front facing down may allow converter to fall off. Whereby an injury may result.

Reverse dismounting procedure for remounting, and then note the following instruction.

- When installing the transmission and transfer to the engine, lift the front of the engine by using the support device (1).

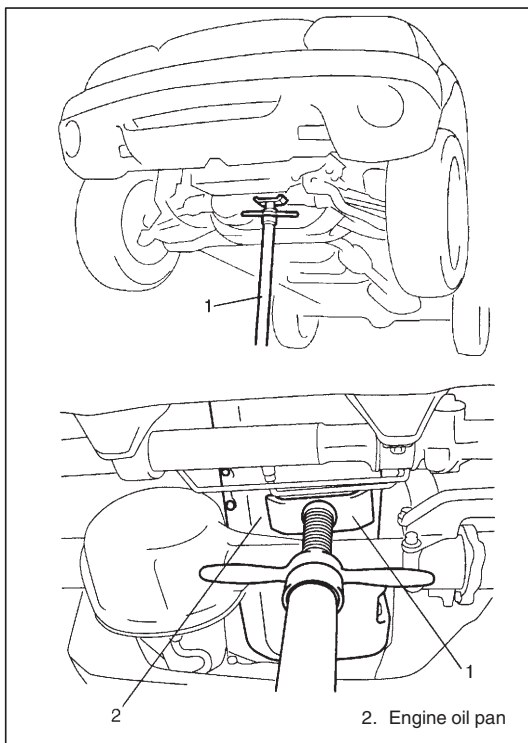

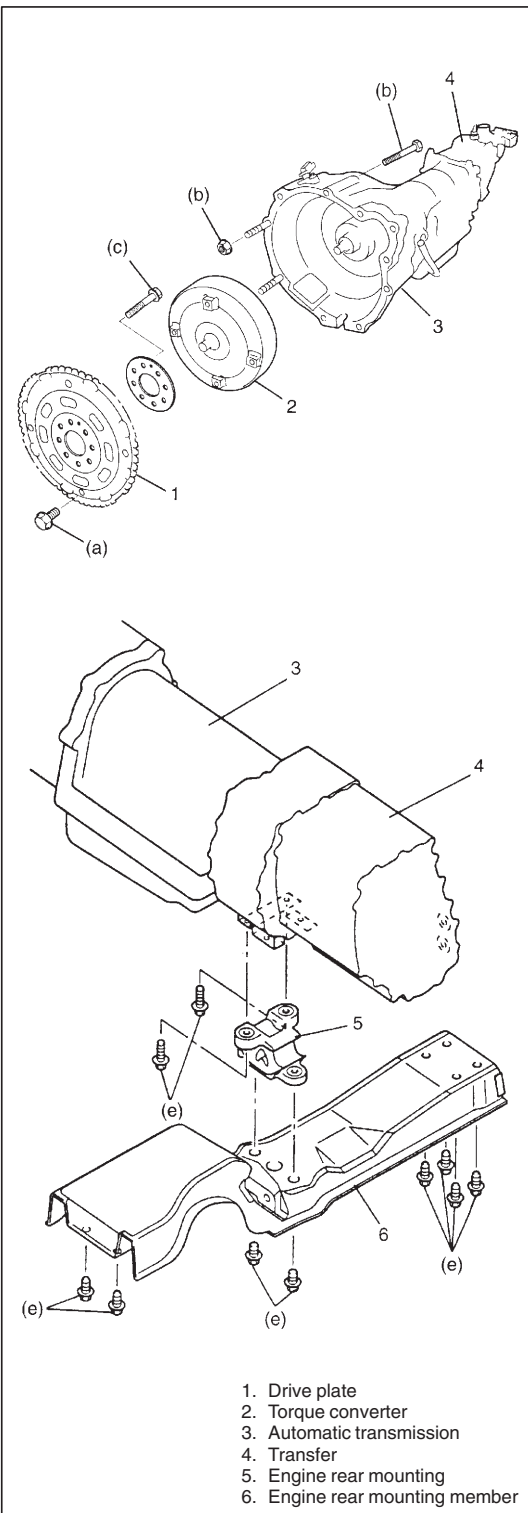

- Tighten bolts and nuts to specified torque.

“A”: Sealant 99000-31110

Tightening torque

Torque converter mounting bolts (a):

65 N·m (6.5 kg-m, 47.0 lb-ft)

Transmission to engine bolts and nuts (b):

61 N·m (6.1 kg-m, 44.0 lb-ft)

Drive plate bolts (c):

50 N·m (5.0 kg-m, 36.5 lb-ft)

Engine rear mounting bolts (e):

50 N·m (5.0 kg-m, 36.5 lb-ft)

Engine rear mounting member bolts (e):

50 N·m (5.0 kg-m, 36.5 lb-ft)

Exhaust No.1 pipe to manifold nuts:

50 N·m (5.0 kg-m, 36.5 lb-ft)

Exhaust No.2 pipe to No.1 pipe bolts:

50 N·m (5.0 kg-m, 36.5 lb-ft)

Muffler to exhaust No.2 pipe nuts:

60 N·m (6.0 kg-m, 43.5 lb-ft)

Front propeller shaft universal joint flange bolts:

50 N·m (5.0 kg-m, 36.5 lb-ft)

Rear propeller shaft universal joint flange bolts:

60 N·m (6.0 kg-m, 43.5 lb-ft)

Oil filler tube bolt: 23 N·m (2.3 kg-m, 17.0 lb-ft)

Select cable bracket bolts: 23 N·m(2.3 kg-m, 17.0 lb-ft)

Stabilizer bar mount bush bracket bolts:

23 N·m (2.3 kg-m, 17.0 lb-ft)

- Clamp wiring harness and hoses securely.
- Refer to “SELECT CABLE” in this section for adjusting procedure of select cable.
- Follow fluid level check procedure for refilling automatic transmission fluid and its level adjusting.
- Connect battery, and confirm that engine and transmission function acceptably.
- When remounting drive plate, use specified bolts.

UNIT REPAIR

NOTE:

Refer to the same section of the Unit Repair Manual mentioned in FOREWORD of this manual for the descriptions not found in this item.

When repairing automatic transmission, it is necessary to conduct the on-vehicle test to investigate where the cause of the trouble lies first.

Then whether overhaul should be done or not is determined. If the transmission is disassembled without such preliminary procedure, not only the cause of the trouble would be unknown, but also a secondary trouble may occur and often time would be wasted.

PRECAUTIONS

As the automatic transmission consists of high precision components, the following cautions should be strictly observed when handling its parts in disassembly and reassembly.

- Disassembling valve body assembly is prohibited essentially. However, a few parts can be disassembled. When disassembling valve body component parts, confirm whether their parts are allowed to disassemble or not referring to "VALVE BODY ASSEMBLY" in this section.
- Make sure to wash dirt off from the transmission so that no such dirt will enter the transmission during dismounting and remounting.
- Select a clean place free from dust and dirt for overhauling.
- Place a rubber mat on the work bench to protect parts from damage.
- Work gloves or shop cloth should not be used. (Use a nylon cloth or a paper towel.)
- When separating the case joint, do not pry with a screwdriver or such but tap with a plastic hammer lightly.
- Make sure to wash dirt off from the transmission so that no such dirt will enter the transmission during disassembly and reassembly.
- Wash the disassembled parts in ATF (Automatic Transmission Fluid) or kerosene (using care not to allow ATF or kerosene to get on your face, etc.) and confirm that each fluid passage is not clogged by blowing air into it. But use ATF to wash the disc, resin washers and rubber parts.
- Replace each gasket, oil seal and O-ring with a new one.
- Apply ATF to sliding or rotating parts before reassembly.
- A new disc should be soaked in ATF at least 2 hours before use.

PART INSPECTION AND CORRECTION TABLE

Part	Inspect for	Correction
Casted part, machined part	Small flaw, burr	Remove with oil stone.
	Deep or grooved flaw	Replace part.
	Clogged fluid passage	Clean with air or wire.
	Flaw on installing surface, residual gasket	Remove with oil stone or replace part.
	Crack	Replace part.
Bearing	Unsmooth rotation	Replace.
	Streak, pitting, flaw, crack	Replace.
Bushing, thrust washer	Flaw, burr, wear, burning	Replace.
Oil seal, gasket	Flawed or hardened seal ring	Replace.
	Worn seal ring on its periphery or side	Replace.
	Piston seal ring, oil seal, gasket, etc.	Replace.
Gear	Flaw, burr	Replace.
	Worn gear tooth	Replace.
Splined part	Burr, flaw, torsion	Correct with oil stone or replace.
Snap ring	Wear, flaw, distortion	Replace.
	No interference	Replace.
Thread	Burr	Replace.
	Damage	Replace.
Spring	Settling, sign of burning	Replace.
Clutch disc, brake disc	Wear, burning, distortion, damaged claw	Replace.
Clutch plate, brake plate	Wear, burning, distortion, damaged claw	Replace.
Sealing surface (where lip contacts)	Flaw, rough surface, stepped wear, foreign material	Replace.

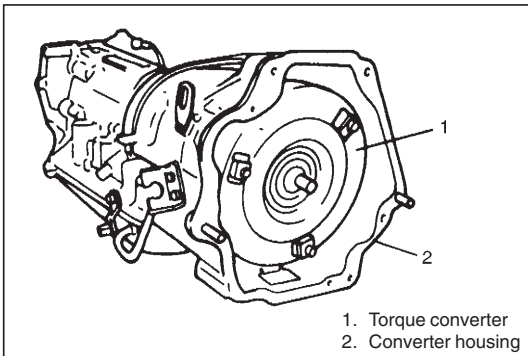

UNIT DISASSEMBLY

- 1) Extract torque converter.

CAUTION:

Remove torque converter as much straight as possible. Leaning it may cause to damage oil seal lip.

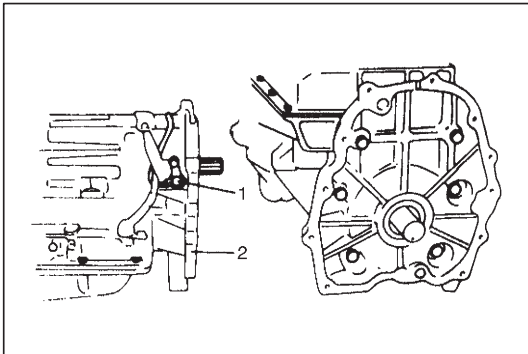

- 2) Remove output shaft speed sensor (1).
- 3) Remove 6 adapter case fixing bolts and then remove adaptor case (2).

NOTE:

Use care not to cause damage to oil seal.

- 4) Remove gasket.

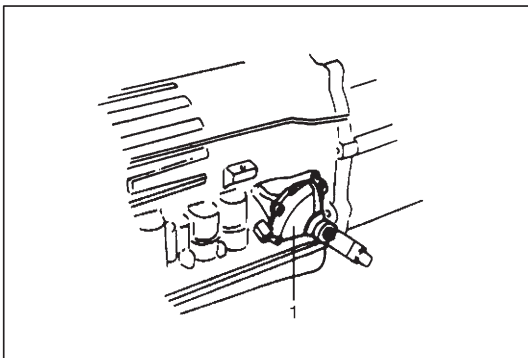

- 5) Remove transmission range sensor (1).

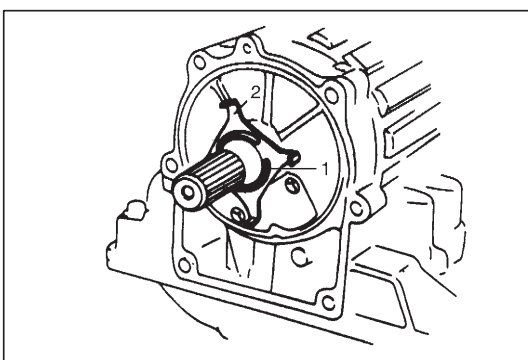

- 6) Remove C-ring (1) and then remove speed sensor rotor (2).

NOTE:

Use care not to loose rotor stop key.

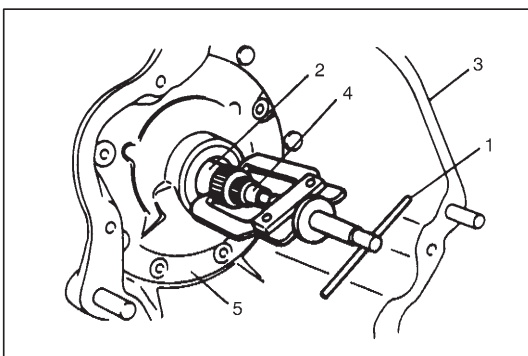

- 7) Remove oil pump (5) by using puller (1).

NOTE:

Use care not to cause damage to shaft bushing surface (2).

- 8) Remove bearing at the rear of oil pump (5).
- 9) Remove O-ring from oil pump (5).
- 10) Holding input shaft (4) by hand, remove converter housing (3).

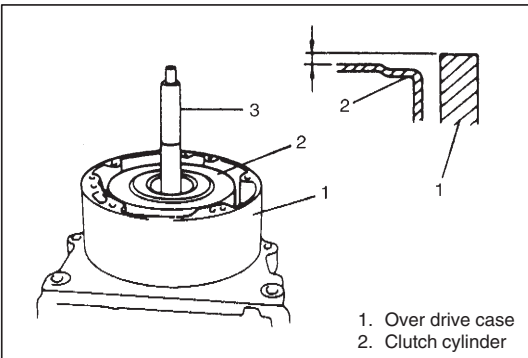

- 11) Check dimensions of overdrive (O/D) case surface and clutch cylinder surface for reassembly.
- 12) Remove overdrive (O/D) clutch assembly by holding input shaft (3).
- 13) Remove O/D case, bearing and bearing race.

NOTE:

Confirm direction of bearing and bearing race for reassembly.

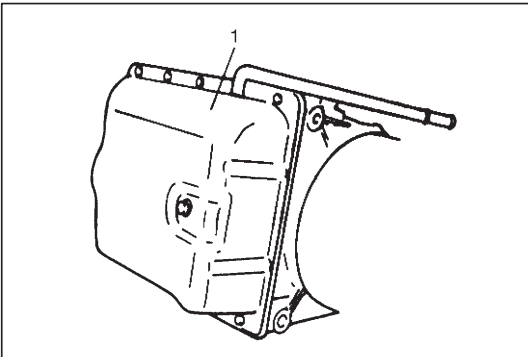

- 14) Remove oil pan (1) and oil pan gasket.

NOTE:

- Hold oil pan with oil pan side down to prevent foreign material in oil pan from entering valve body.
- If iron powder is found, it is possible that bearing, gear or clutch plate is worn.

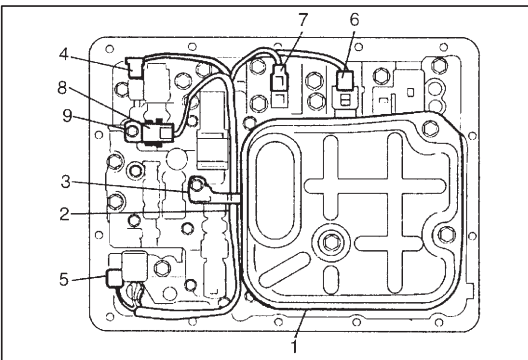

- 15) Remove oil strainer (1).
- 16) Remove wire harness (2) from wire harness clamp (3).
- 17) Disconnect the following connectors.
 - Shift solenoid-A connector (4)
 - Shift solenoid-B connector (5)
 - TCC solenoid connector (6)
 - Pressure control solenoid connector (7)
- 18) Remove transmission fluid temperature sensor (8) from sensor clamp (9).

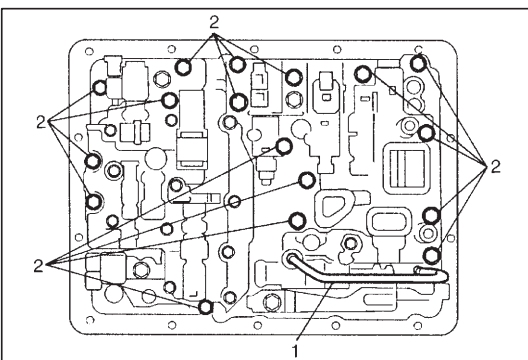

- 19) Remove oil pipe (1).
- 20) Remove valve body mounting bolts (2) as shown in the figure.

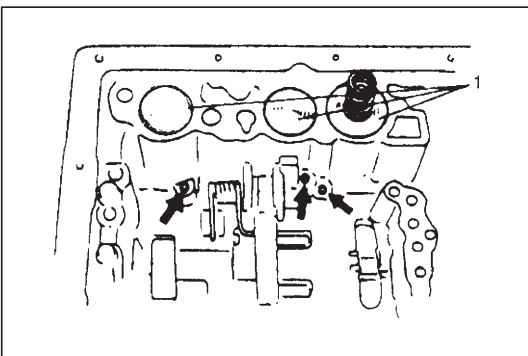

- 21) Remove accumulator pistons (1) by blowing air into holes indicated in the figure.

NOTE:

Hold accumulator piston (1) with shop cloth while blowing.

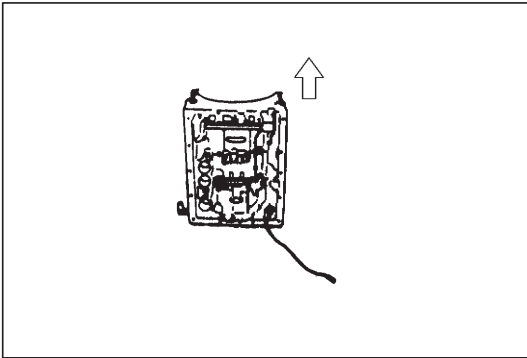

22) Place transmission upright as shown in the figure.

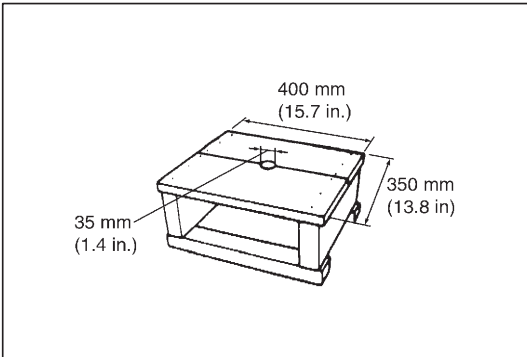

NOTE:

- To prevent transmission case from getting damaged, protect its contacting surface with stand by using shop cloth or the like.
- A stand of such size as shown in the figure will facilitate work.

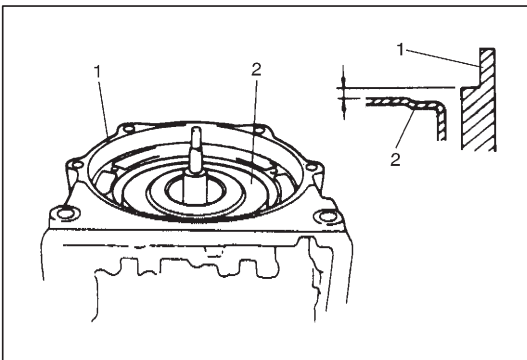

23) Check top surface level of forward clutch (2) against case (1) for reassembly.

24) Remove forward clutch.

NOTE:

- Confirm direction of bearing and bearing race for reassembly.

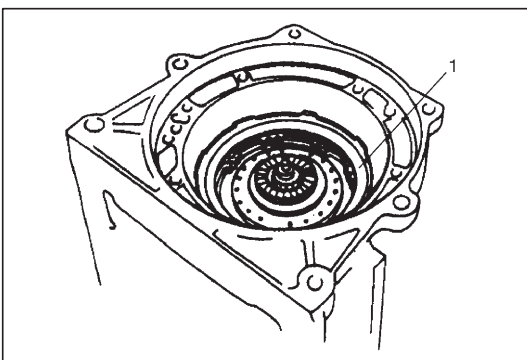

25) Remove direct clutch (1).

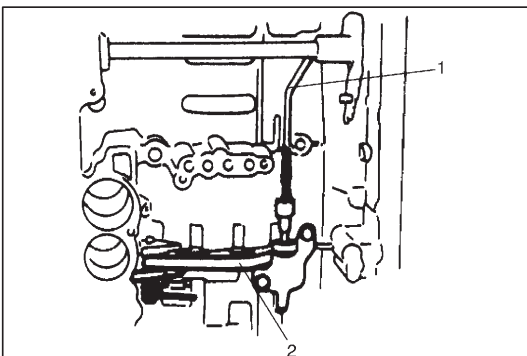

26) Remove parking rod (1) and parking pawl (2).

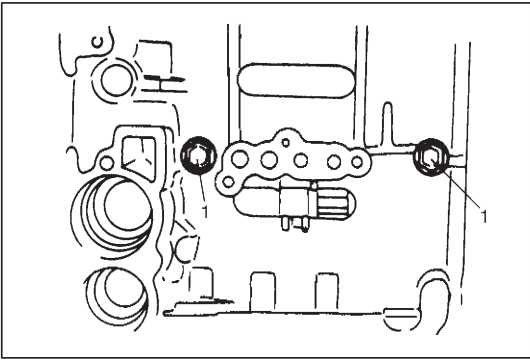

27) Remove 2 bolts (1) from valve body side to remove center support.

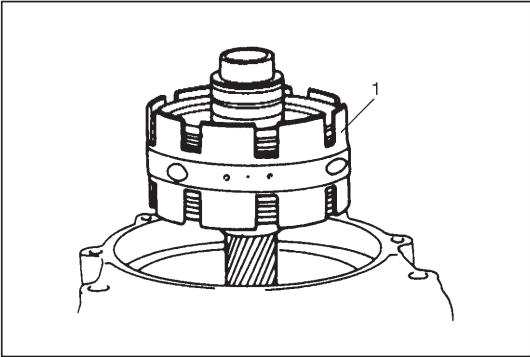

28) Remove center support assembly (1).

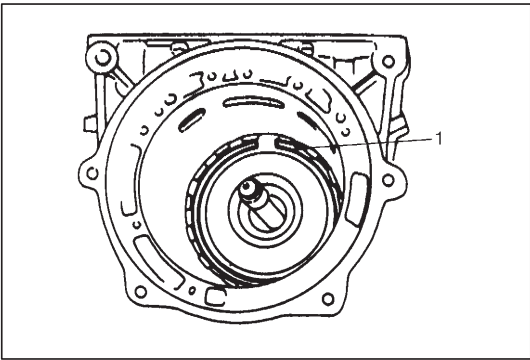

29) Remove retaining ring (1), planetary gear assembly and leaf spring.

NOTE:

- Use care not to cause damage to case when removing retaining ring.
- Confirm direction of bearing and bearing race for reassembly.

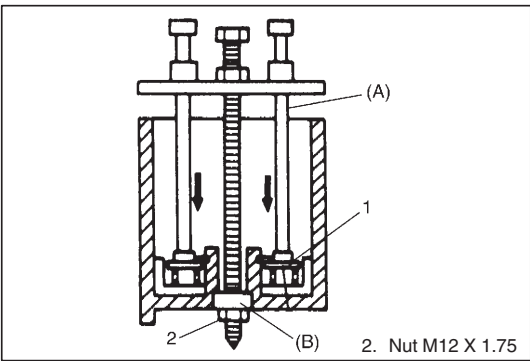

30) Remove reverse brake retainer (1).

Special tool

- (A): 09941-84510
- (B): 09926-98320

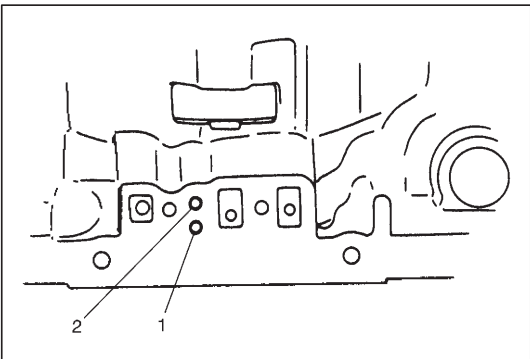

31) Remove rear action sleeve and reverse brake piston by blowing air into hole (1) with hole (2) closed.

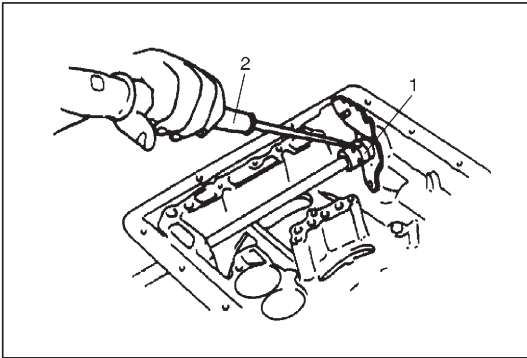

32) Undo caulking of sleeve cover (1) by using moderate stick (2) and move sleeve cover.

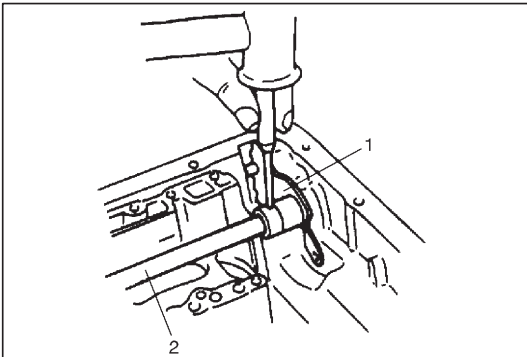

33) Using a punch, drive out manual shift lever pin, pull out manual shift shaft (2) and remove manual shift lever (1). Then remove sleeve cover from manual shift lever (1).

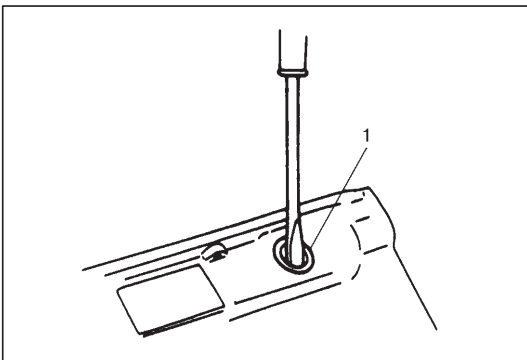

34) Remove oil seal (1) from both sides of transmission case.

SUB-ASSEMBLY REPAIR OVERDRIVE (CASE SIDE)

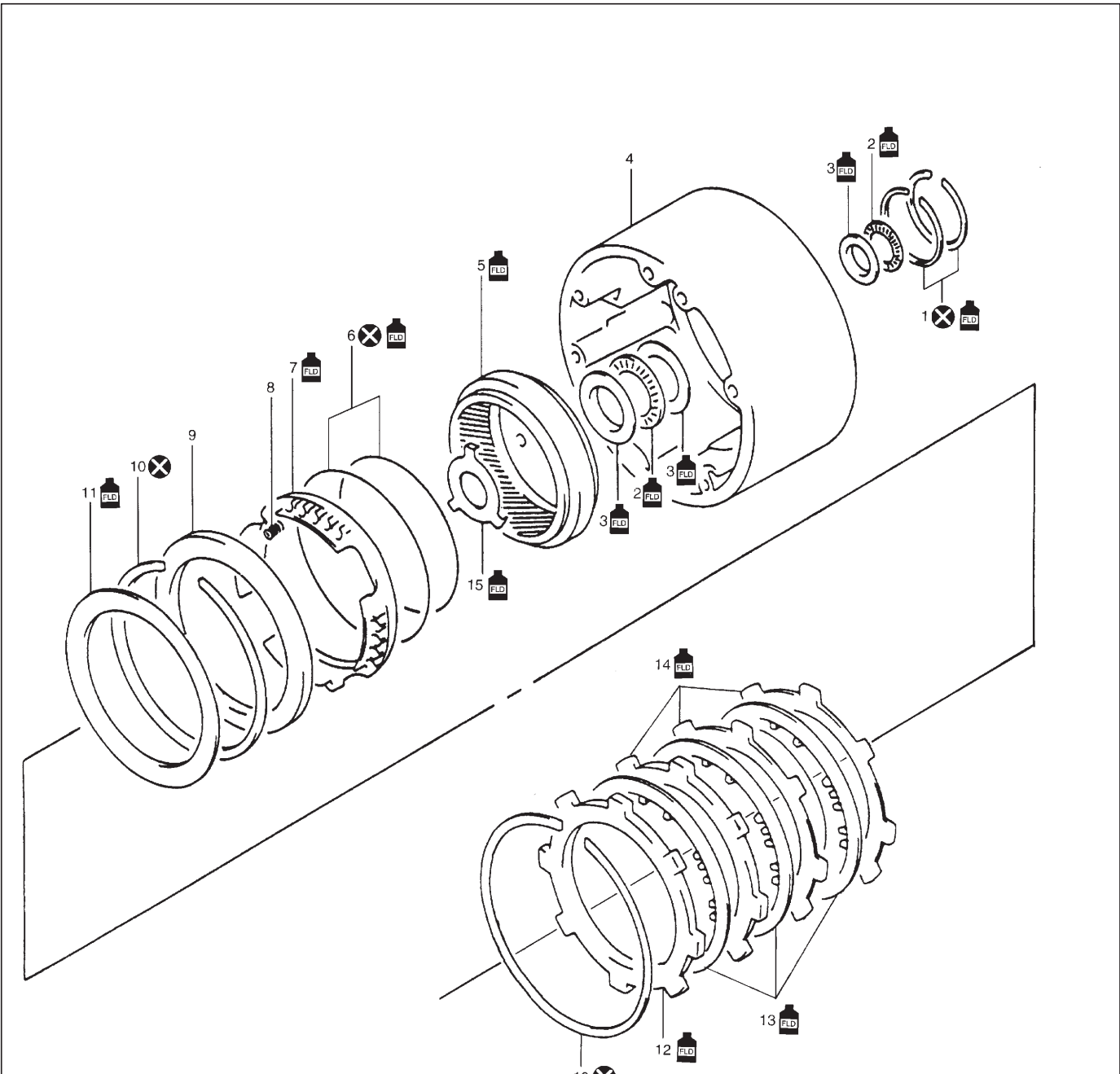

- 1. Sealing
- 2. Bearing
- 3. Bearing race
- 4. O/D case
- 5. Planetary ring gear
- 6. O-ring
- 7. Brake piston
- 8. Return spring
- 9. Retainer
- 10. Retaining ring
- 11. Cushion plate
- 12. Brake backing plate
- 13. Brake disc
- 14. Brake plate
- 15. Thrust race

⊗ : Do not reuse.

FLD : Apply automatic transmission fluid.

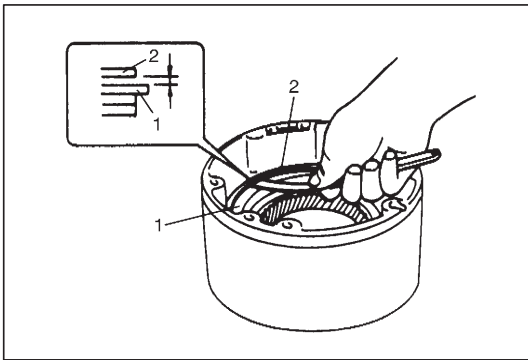

DISASSEMBLY

- 1) Measure clearance between retaining ring (1) and brake backing plate (2) with thickness gauge. If it is not within standard range, adjust it to standard clearance with selective brake plates shown below.

**Clearance between retaining ring and brake backing plate
Standard:**

0.75 – 1.25 mm (0.030 – 0.049 in.)

Available plate thickness	2.0, 2.3 mm (0.079, 0.091 in.)
----------------------------------	---------------------------------------

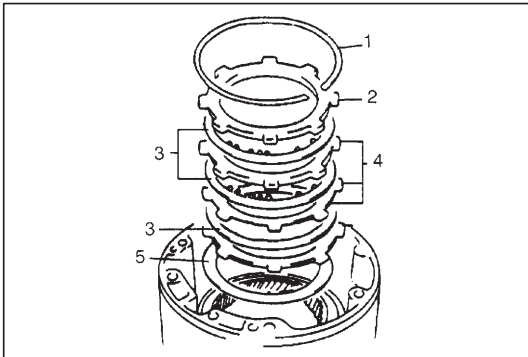

- 2) Remove retaining ring (1), brake backing plate (2), brake disc (3), brake plate (4), cushion brake plate (5) in that order. Then remove planetary ring gear, thrust bearing race and thrust rear bearing.

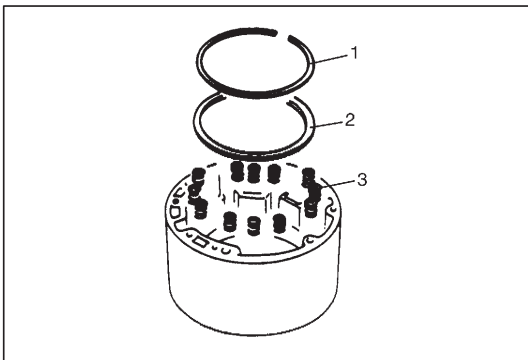

- 3) Remove retaining ring (1), retainer (2) and piston return spring (3).

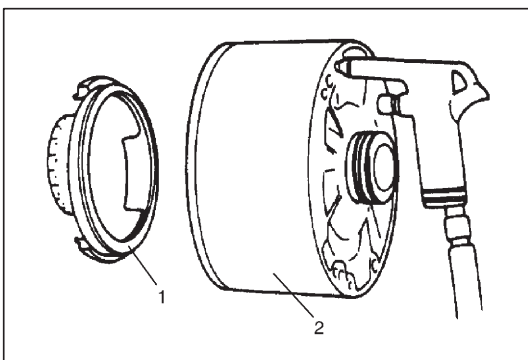

- 4) Blow air into fluid hole in O/D case (2) and remove brake piston (1).
- 5) Remove brake piston inner ring and brake piston outer ring from brake piston.

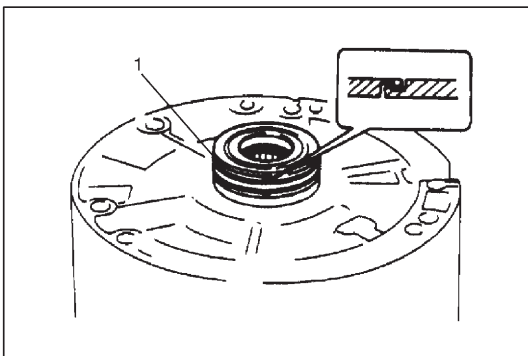

- 6) Unsnap seal ring (1).
- 7) Remove 2 seal rings (1).

NOTE:

Be careful not to open seal ring more than necessary.

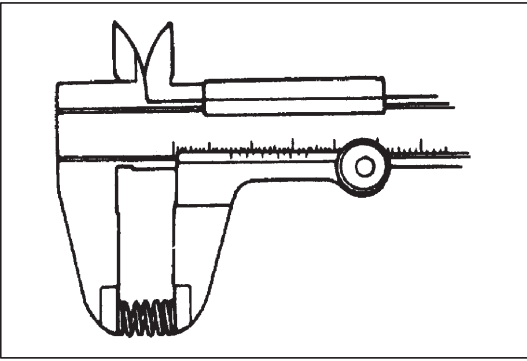

INSPECTION

- Measure free length of piston return spring.

**Standard free length of piston return spring:
16.60 mm (0.654 in.)**

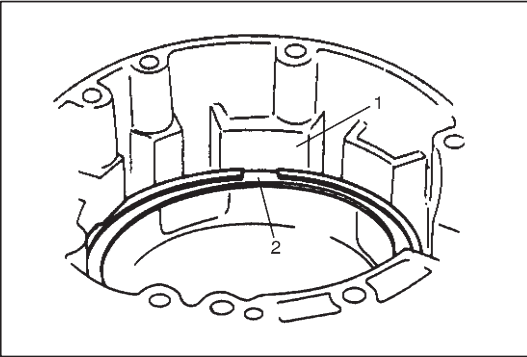

ASSEMBLY

Install each component by reversing removal procedure and noting the following points.

- When installing rear seal ring, use care not to open it too wide.
- Apply A/T fluid to O-ring, disc, etc. before installing them.
- Opening of retaining brake front ring (2) and projection (1) of O/D case should be matched.
- When installing each component, refer to the first figure of "OVER DRIVE (CASE SIDE)" in this section.

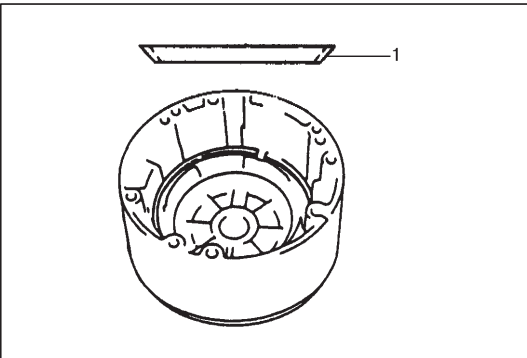

- Install cushion brake plate (1) so that it warps convexly.
- As a final step, measure clearance between retaining brake front ring and brake backing plate again.

**Standard clearance between retaining brake front ring and
brake backing plate:
0.75 – 1.25 mm (0.030 – 0.049 in.)**

FORWARD CLUTCH

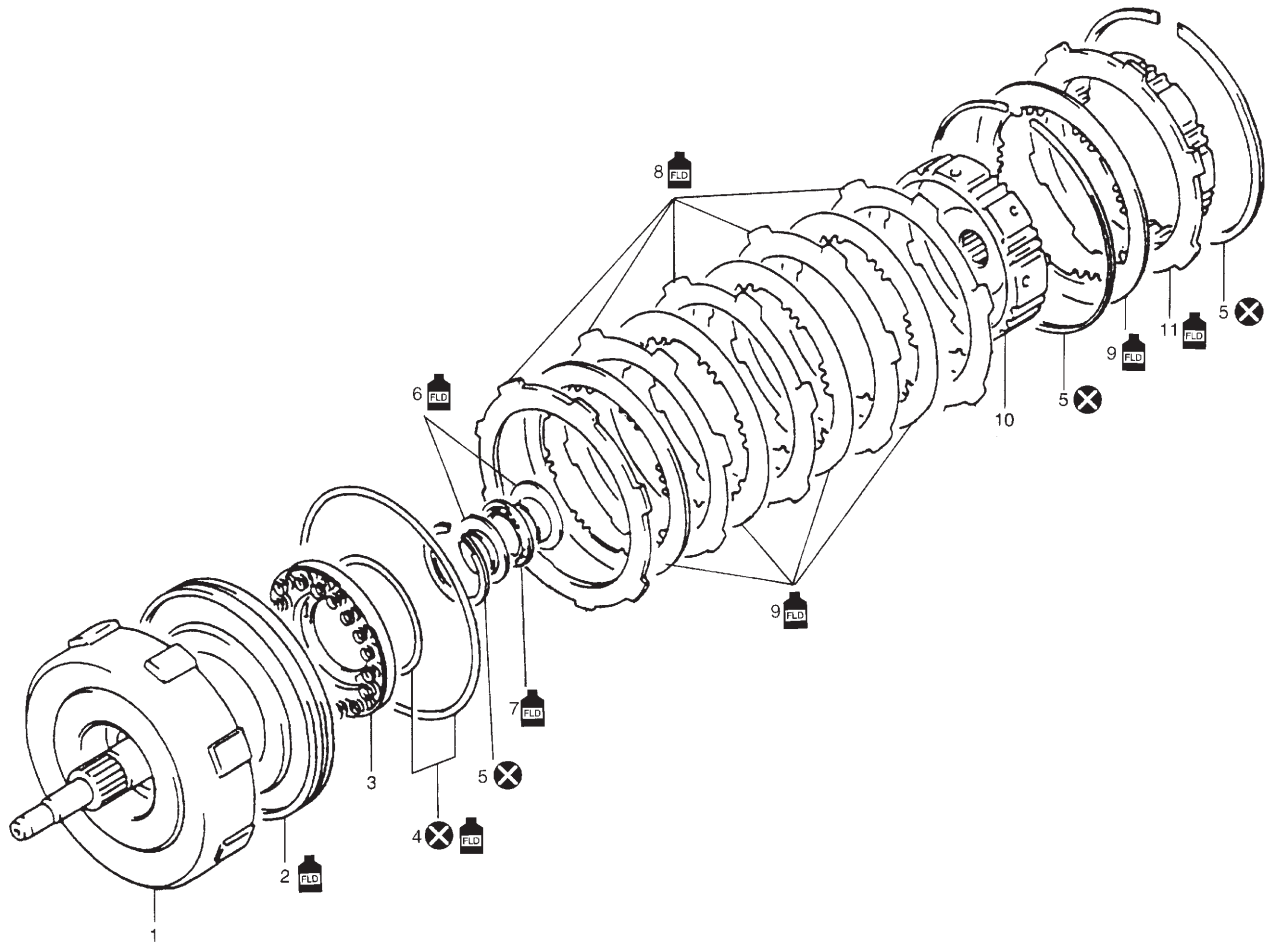

1. Input shaft
 2. Piston
 3. Return spring
 4. O-ring
 5. Retaining ring
 6. Bearing race
 7. Bearing
 8. Clutch plate
 9. Clutch disc
 10. Forward clutch hub
 11. Direct clutch input hub
- ⊗ : Do not reuse.
- FLD : Apply automatic transmission fluid.

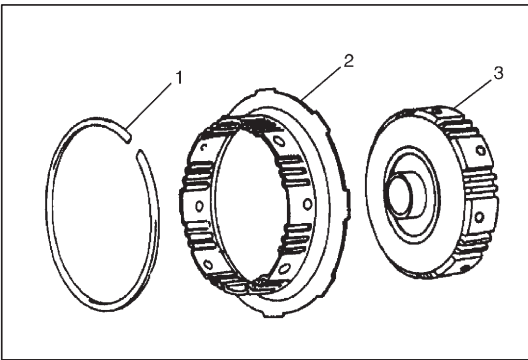
**DISASSEMBLY**

1) After removing retaining ring (1), remove direct clutch input hub (2) and forward clutch hub (3).

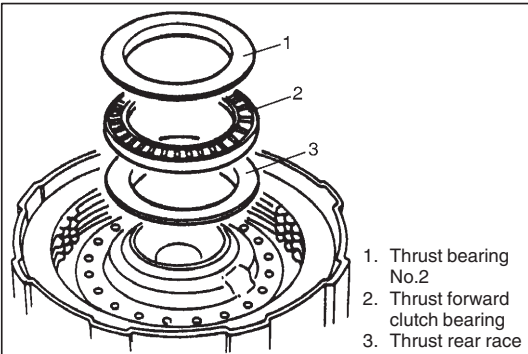

2) Remove bearing race and thrust bearing.

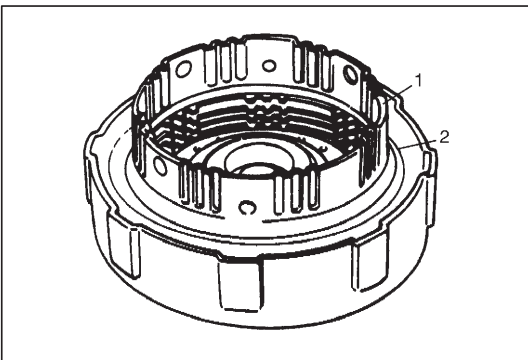

3) Install direct clutch input hub (1) and retaining ring (2).

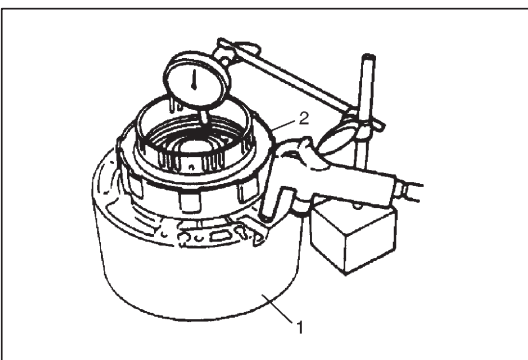

4) Install forward clutch (2) to O/D case (1). Apply 4 – 8 kg/cm² air pressure into fluid hole at the right of cut in O/D case and measure movement of forward clutch piston.

If measured value is not within standard range, adjust it to standard value with selective clutch plates shown below.

Standard forward clutch piston movement:

1.40 – 1.70 mm (0.056 – 0.067 in.)

Available plate thickness	1.8, 2.0 mm (0.071, 0.079 in.)
----------------------------------	---------------------------------------

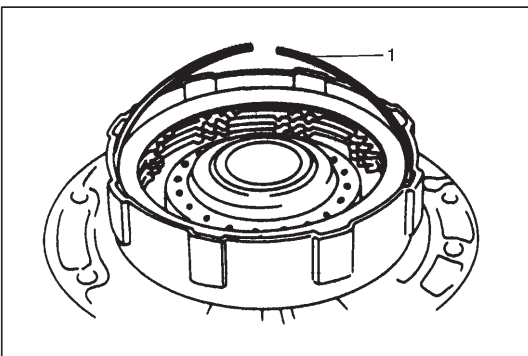

5) Remove retaining ring (1) and then remove direct clutch input hub.

6) Remove retaining ring and then remove all clutch discs.

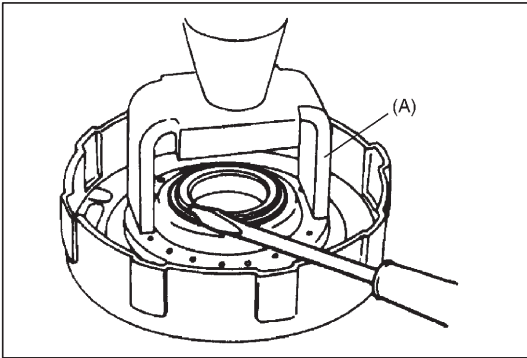

- 7) Using special tool and hydraulic press, compress forward clutch piston return spring and remove retaining return spring.

Special tool (A): 09926-98310

CAUTION:

Be careful when applying pressure, for overpressure will cause plate section of piston return spring to deform.

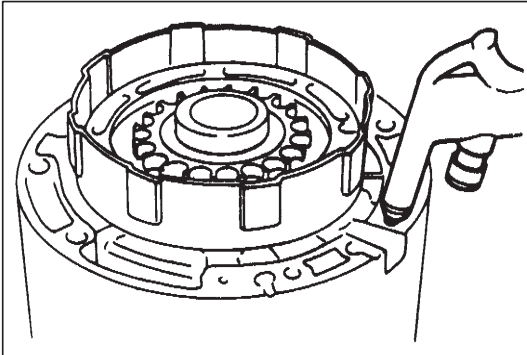

- 8) Remove forward clutch piston return spring.
- 9) Install forward clutch to O/D case. Blow low pressure air into fluid hole at the right of cut in O/D case to remove forward clutch piston.

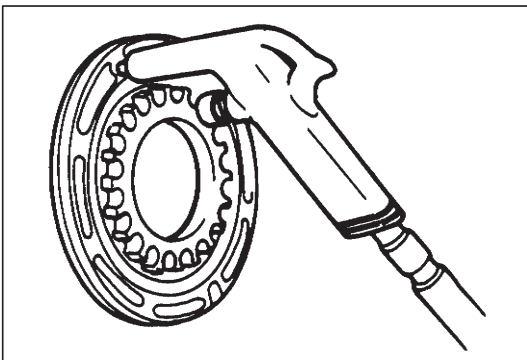

INSPECTION

Forward Clutch Piston

- Shake piston to check that ball is not stuck.
- Blow low pressure air to check ball section for leakage.

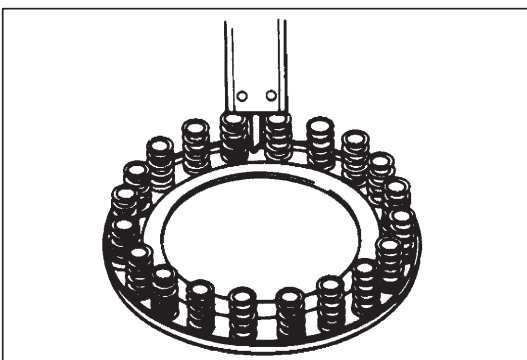

Forward Clutch Piston Return Spring

- Measure free length.

**Standard free length of forward clutch piston return spring:
19.21 mm (0.756 in.)**

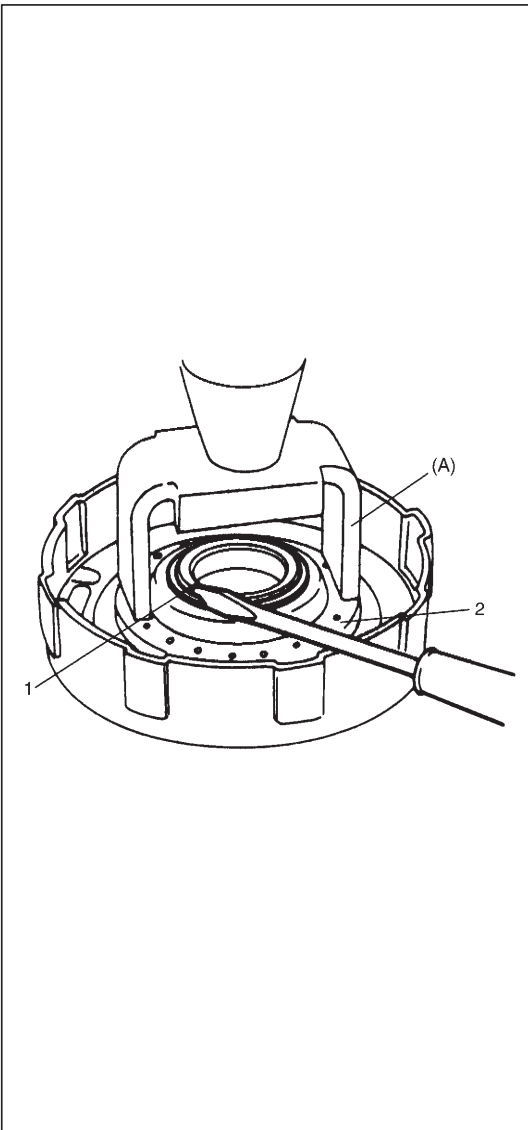

INSTALLATION

- 1) Apply A/T fluid to forward input shaft O-rings, install forward clutch piston and piston return spring (2) to forward input shaft and then install return spring ring with special tool and hydraulic press.

Special tool

(A): 09926-98310

NOTE:

- When installing return spring (2), be careful so that return spring (2) will not fall or tilt.
- Do not align opening in retaining ring (1) with lug of forward clutch piston return spring (2) at its retainer section.

CAUTION:

Be careful when applying pressure, for overpressure will cause plate section of piston return spring to deform.

NOTE:

- Refer to the first figure of "FORWARD CLUTCH" in this section. When installing each component.
- Do not match opening in retaining clutch ring and dent in forward clutch input shaft.

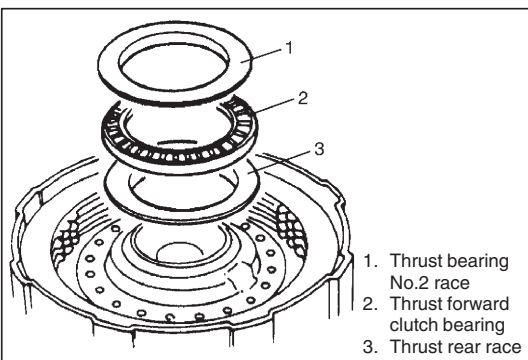

- 2) Install bearing races and thrust bearing.

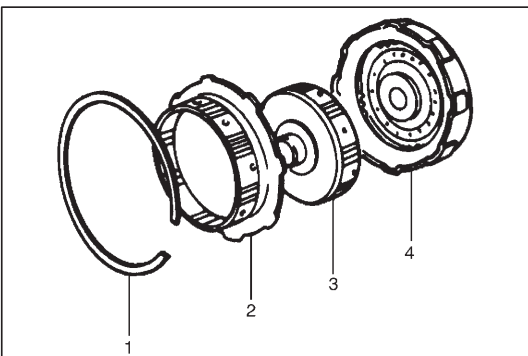

- 3) Install forward clutch hub (3), direct clutch hub (2) and retaining ring (1) to input shaft (4) in that order.

DIRECT CLUTCH

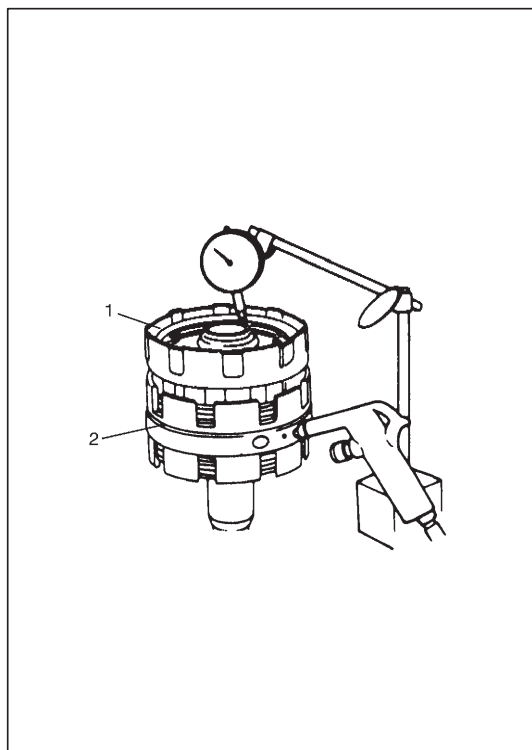
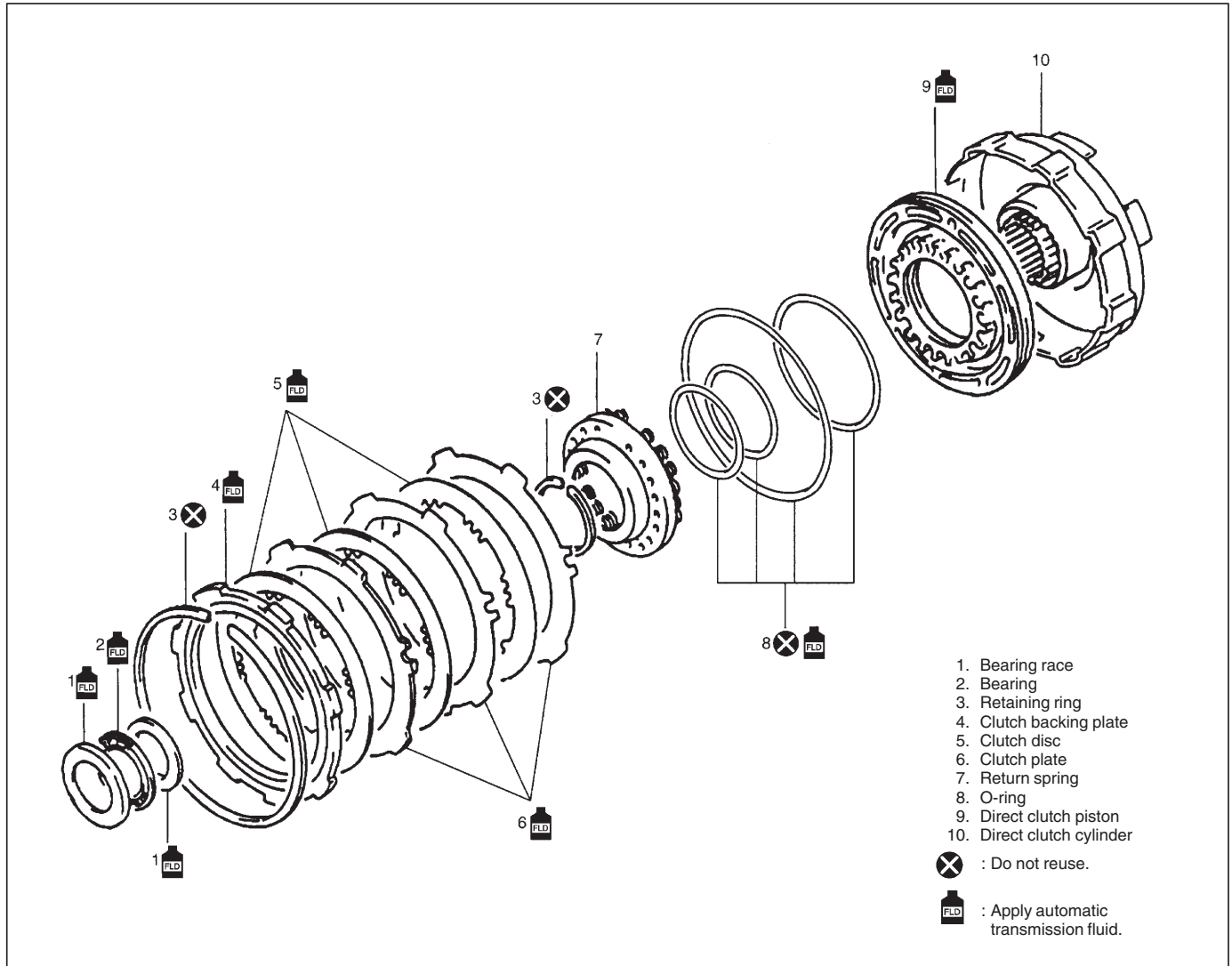

DISASSEMBLY

1) Install direct clutch assembly (1) to center support (2) and with 4 – 8 kg/cm² air pressure applied to second fluid hole from the left, measure stroke of direct clutch piston as shown in figure. If it is not within standard range, adjust it to standard stroke with selective clutch backing plates shown below.

Standard direct clutch piston stroke:

0.90 – 1.30 mm (0.035 – 0.051 in.)

Available backing plate thickness	3.55, 3.75, 4.00 mm (0.140, 0.148, 0.157 in.)
-----------------------------------	--

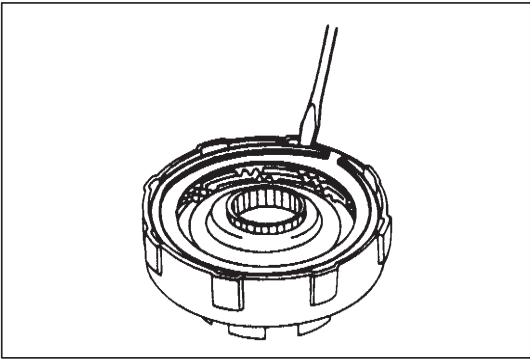

- 2) Remove direct clutch assembly from center support and then remove retaining ring.

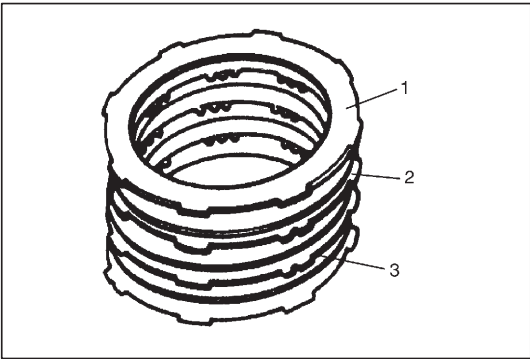

- 3) Remove clutch backing plate (1) and then remove clutch disc (3) and clutch plate (2).

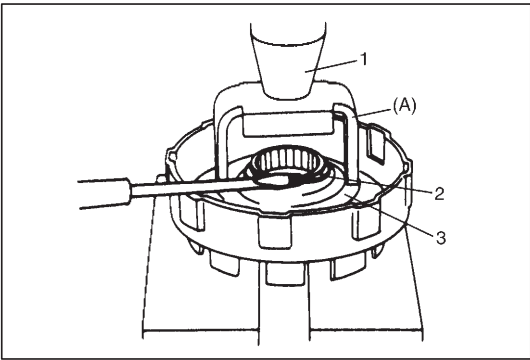

- 4) Using special tool and hydraulic press (1), compress direct clutch piston return spring (3) and remove retaining return spring ring (2).

Special tool
(A): 09926-98310

CAUTION:
Be careful when applying pressure, for overpressure will cause plate section of piston return spring to deform.

- 5) Remove direct clutch piston return spring.

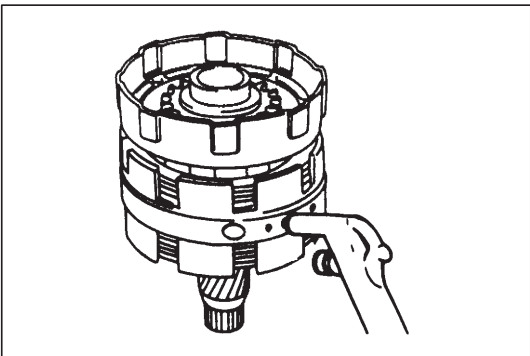

- 6) Install direct clutch cylinder to center support. Remove direct clutch piston by blowing air into the second hole from the left as shown in the figure. And then remove O-rings from piston.

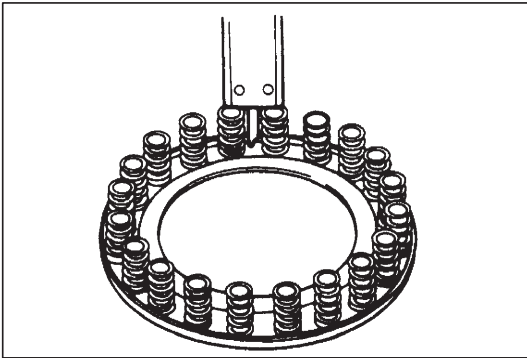

INSPECTION

Direct Clutch Piston Return Spring

- Measure free length.

**Standard free length of direct clutch piston return spring:
15.13 mm (0.595 in.)**

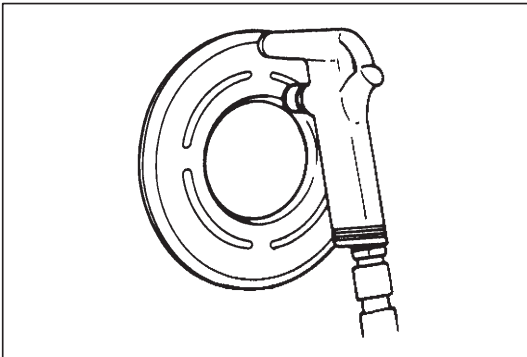

Direct Clutch Piston

- Shake piston to check that ball is not stuck.
- Apply air pressure and check that there is no leakage.

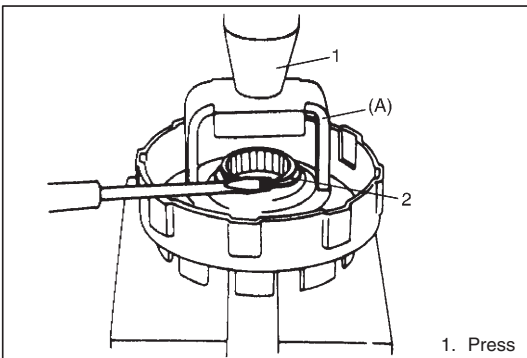

ASSEMBLY

Assemble each component by reversing disassembly procedure and noting the following points.

- Always use new O-ring and apply A/T fluid before installation.
- Do not align opening in retaining ring (2) with lug of direct clutch piston return spring at retainer.

Special tool

(A): 09926-98310

- Use care so that direct clutch piston return spring will not fall or tilt.

CAUTION:

Be careful when applying pressure, for overpressure will cause plate section of piston return spring to deform.

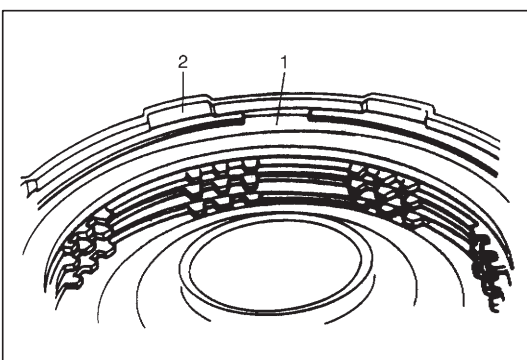

- Do not match opening (1) in retaining back plate ring with cutout (2) in direct clutch cylinder.

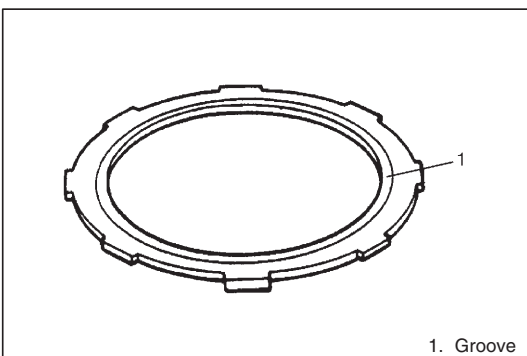

- Install clutch backing plate with its grooved side facing the front.

CENTER SUPPORT

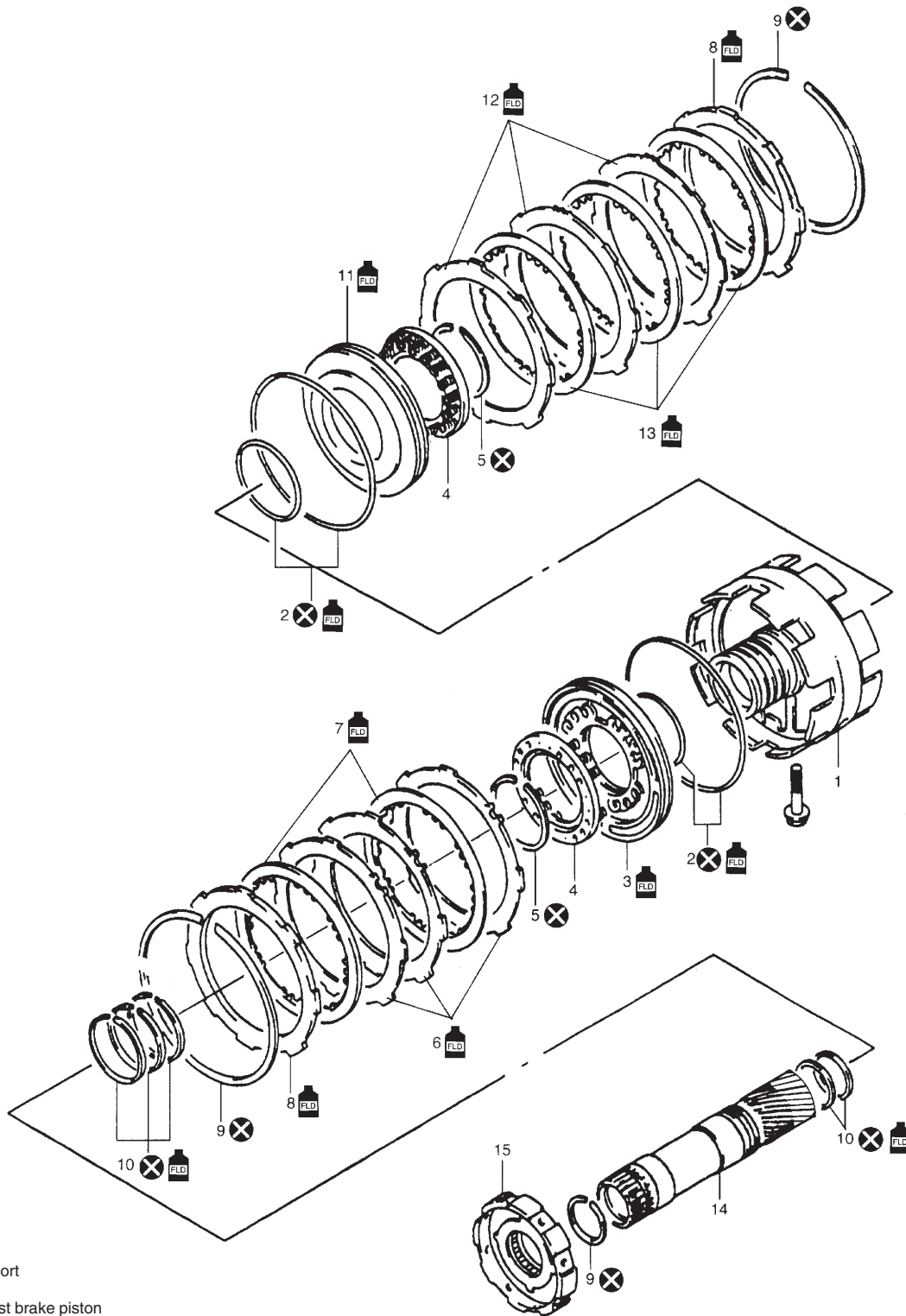

1. Center support
2. O-ring
3. Second coast brake piston
4. Piston return spring
5. Snap ring
6. Second coast brake plate
7. Second coast brake disc
8. Clutch backing plate
9. Retaining ring
10. Seal ring
11. Second brake piston
12. Second brake plate
13. Second brake disc
14. Planetary sun gear
15. Second brake hub assembly

⊗ : Do not reuse.

FLD : Apply automatic transmission fluid.

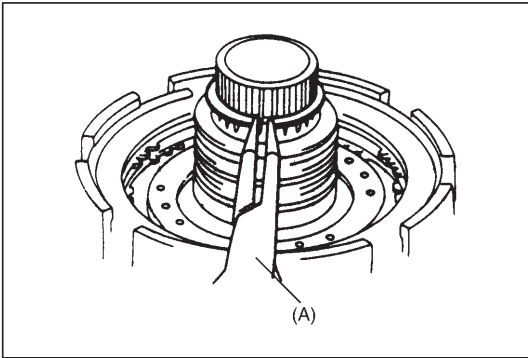

DISASSEMBLY

1) Remove retaining ring.

Special tool

(A): 09920-76010

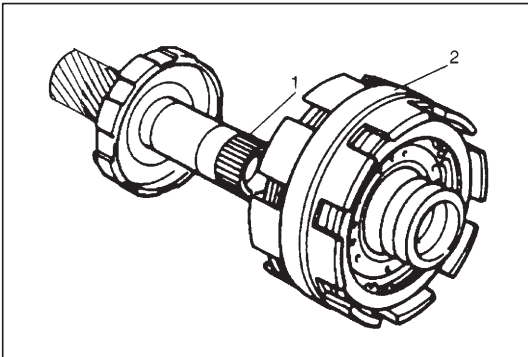

2) Pull out center support assembly (2) from planetary sun gear (1).

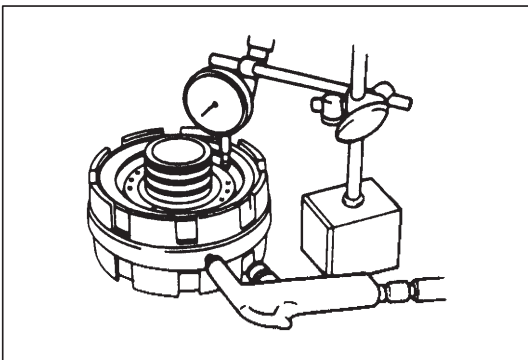

3) Apply 4 – 8 kg/cm² air pressure into fluid hole at the extreme left and measure movement of second coast brake piston. If measured value is not within standard range, replace second coast brake plate or second coast brake disc.

Standard second coast brake piston movement:

1.00 – 1.20 mm (0.039 – 0.047 in.)

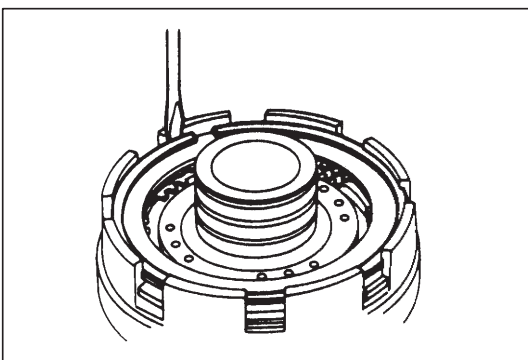

4) Remove retaining ring.

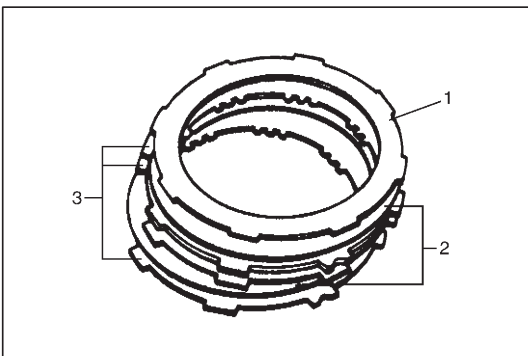

5) After removing clutch backing plate (1), remove second coast brake plates (3) and second coast brake discs (2).

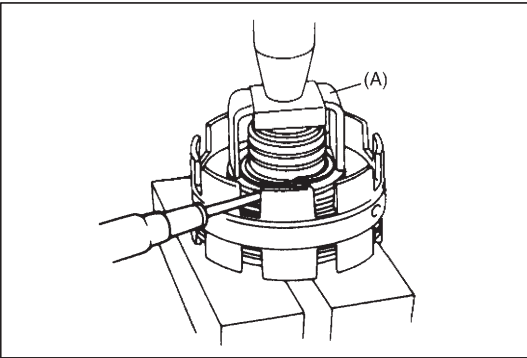

- 6) Using special tool and hydraulic press, compress piston return spring and remove snap ring.

CAUTION:

Be careful when applying pressure, for overpressure will cause plate section of piston return spring to deform.

Special tool

(A): 09926-98310

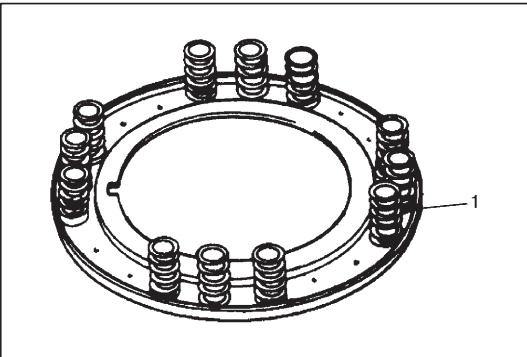

- 7) Remove brake piston return spring (1).

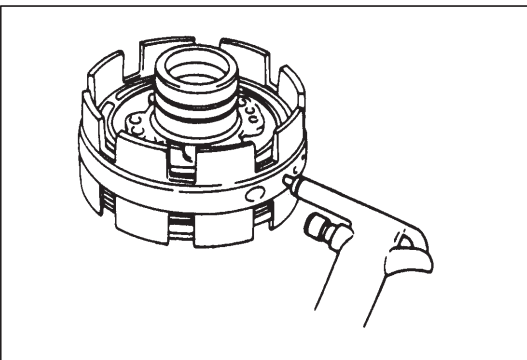

- 8) Blow air into fluid hole at the extreme left and remove second coast brake piston as shown in the figure. Then remove piston inner O-ring and piston outer O-ring from second coast brake piston.

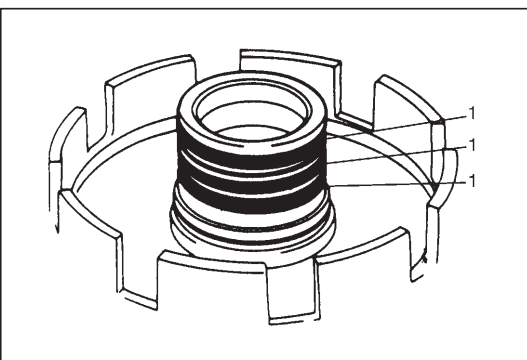

- 9) Remove 3 seal rear rings (1).

NOTE:

Use care not to open ring more than necessary.

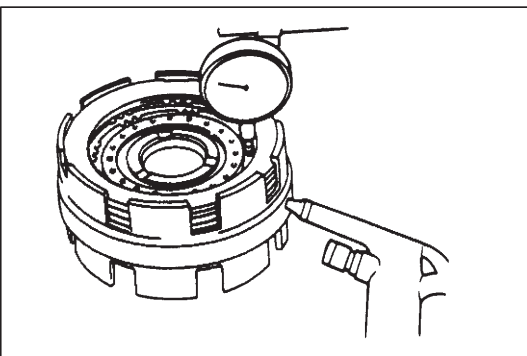

- 10) Apply 4 – 8 kg/cm² air pressure into the second hole from the left and measure stroke of second brake piston as shown in figure.

If measured value is not within standard range, replace second brake plate or second brake disc.

Standard second brake piston stroke:

1.01 – 2.25 mm (0.040 – 0.088 in.)

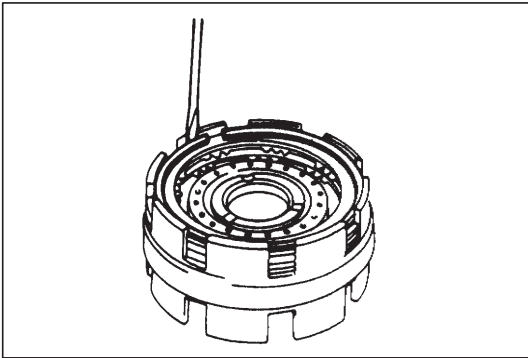

- 11) After removing retaining back plate ring, remove clutch backing plate, second brake plates and second brake discs.

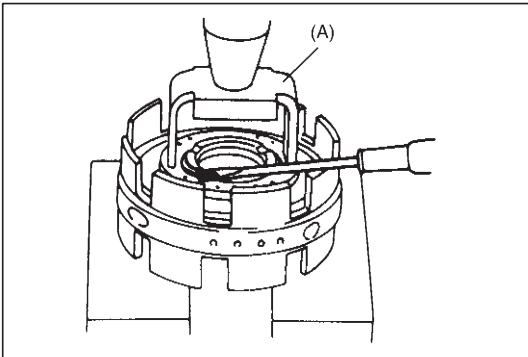

- 12) Using special tool and hydraulic press, compress brake piston return spring and remove snap second brake ring.

CAUTION:

Be careful when applying pressure, for overpressure will cause plate section of piston return spring to deform.

Special tool

(A): 09926-98310

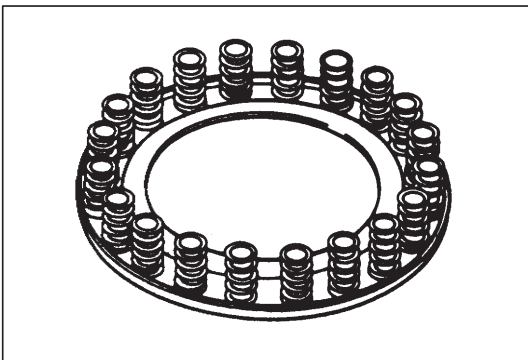

- 13) Remove brake piston return spring.

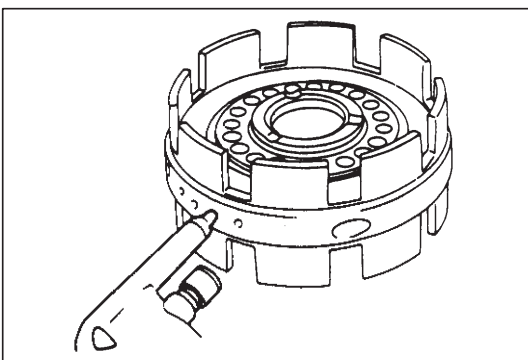

- 14) Blow air into the second air hole from the left and remove second brake piston. Then remove piston inner O-ring and piston outer O-ring from second brake piston.

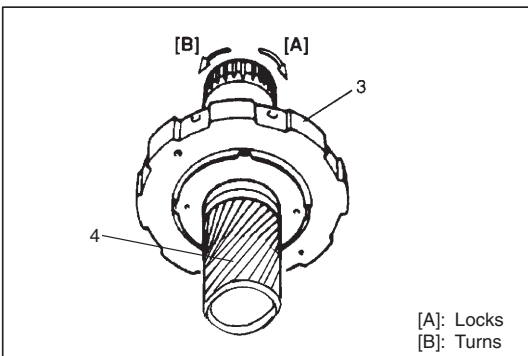

- 15) With second brake hub assembly (3) held stationary, turn planetary sun gear (4) clockwise to check that it locks and then counterclockwise to check that it turns smoothly.

[A]: Locks
[B]: Turns

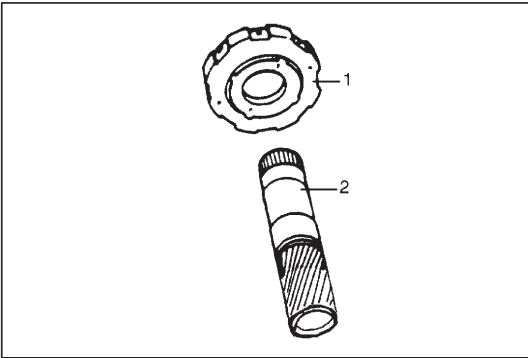

- 16) Remove second brake hub assembly (1) from planetary sun gear (2).

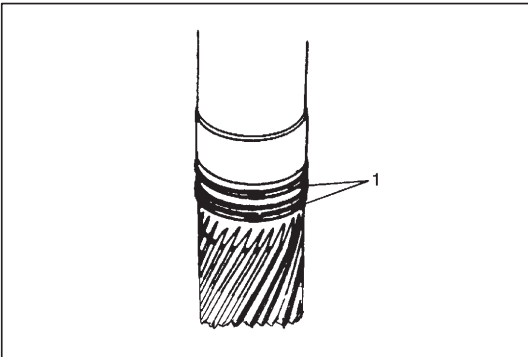

- 17) Remove 2 sun gear seal rings (1) from planetary sun gear.

NOTE:

Use care not to open sun gear seal ring more than necessary.

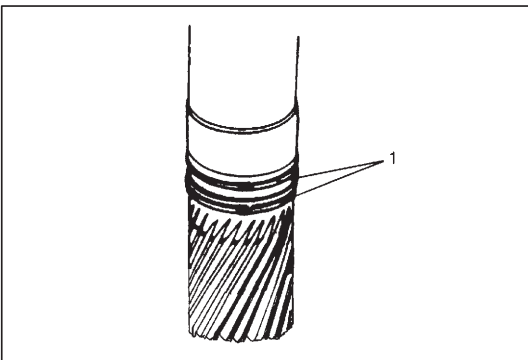

ASSEMBLY

Assemble components by reversing disassembly procedure and noting the following points.

- Snap both ends of sun gear seal ring (1) securely.
 - Do not open sun gear seal ring more than necessary.
 - Always use new O-ring and apply A/T fluid before installation.
 - When installing O-ring, make sure that it is not kinked or caught.
 - Push in brake piston horizontally.
 - When installing brake piston return spring, be careful so that spring will not fall or tilt.
- When installing snap ring, do not align lug (1) of retainer with opening in snap ring (2).

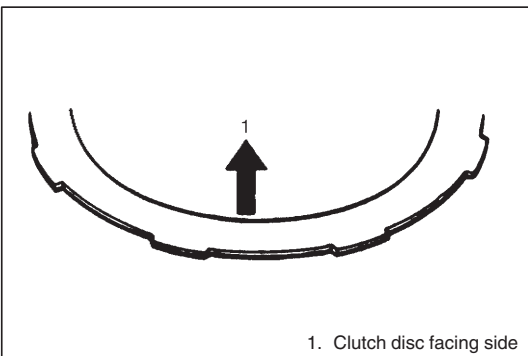
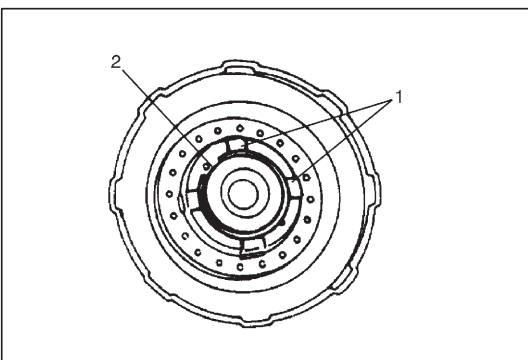

1. Clutch disc facing side

- When installing brake discs, brake plates and clutch backing plate, refer to the first figure of "CENTER SUPPORT" in this section.
- Install clutch backing plate with its chamfered side facing brake disc.

- After installing each retaining backing plate ring, measure movement of brake piston again.
If it is not within standard range, it is possible that ring is not installed properly. Then disassemble and reassemble again.

Standard movement of second coast brake piston:

1.00 – 1.20 mm (0.039 – 0.047 in.)

Standard movement of second brake piston:

1.01 – 2.25 mm (0.040 – 0.088 in.)

PLANETARY GEARS AND OUTPUT SHAFT

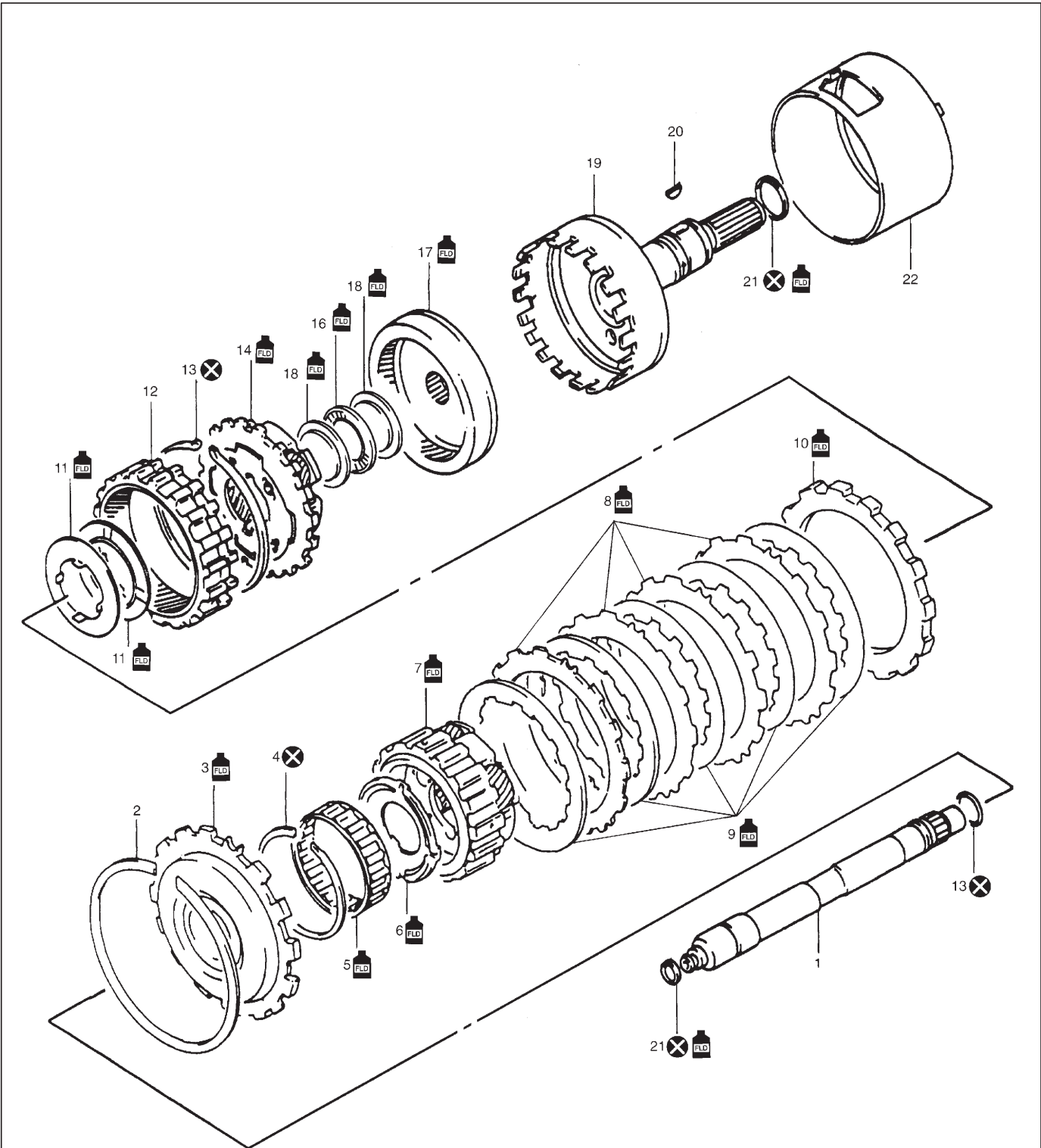

- | | | |
|---------------------------------|-------------------------------|-------------------------|
| 1. Inner shaft | 11. Washer | 21. Seal ring |
| 2. Retaining ring | 12. Front planetary ring gear | 22. Brake applying tube |
| 3. Reverse brake reaction plate | 13. Retaining ring | |
| 4. Retaining ring | 14. Rear planetary gear | |
| 5. One-way clutch | 15. Blank | |
| 6. One-way clutch thrust washer | 16. Bearing | |
| 7. Front planetary gear | 17. Rear planetary ring gear | |
| 8. Reverse brake plate | 18. Bearing race | |
| 9. Reverse brake disc | 19. Output shaft assembly | |
| 10. Reverse brake backing plate | 20. Key | |

 : Apply automatic transmission fluid.

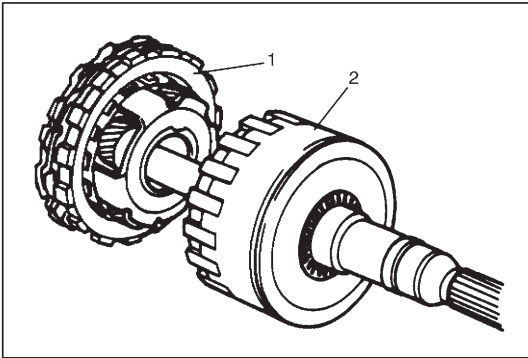

DISASSEMBLY

1) Remove front planetary gear assembly (1) from output shaft assembly (2).

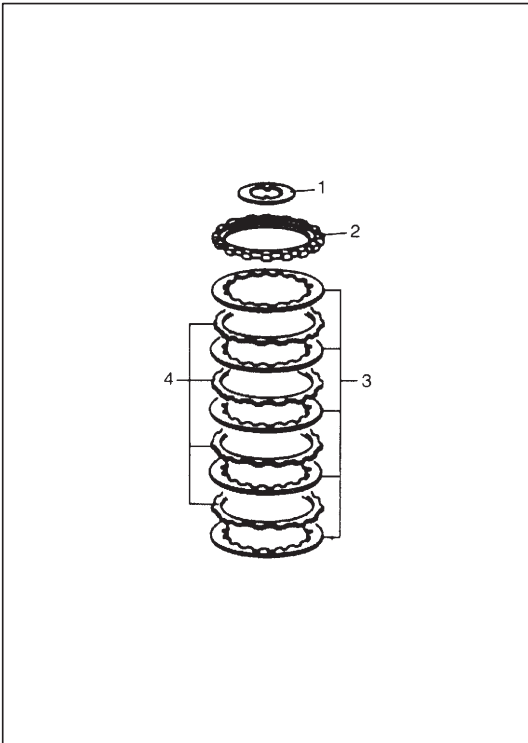

2) Remove rear planetary thrust washer (1), reverse brake backing plate (2), reverse brake disc (3) and reverse brake plate (4) from front planetary gear assembly.

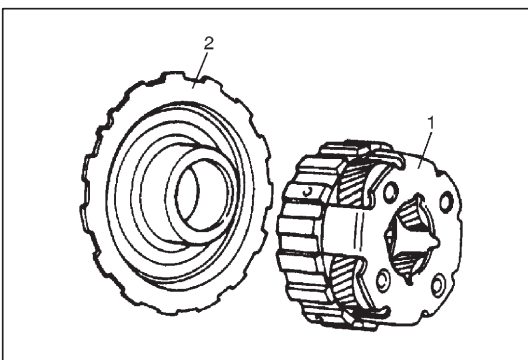

3) Remove reverse brake reaction plate (2) from front planetary gear (1).

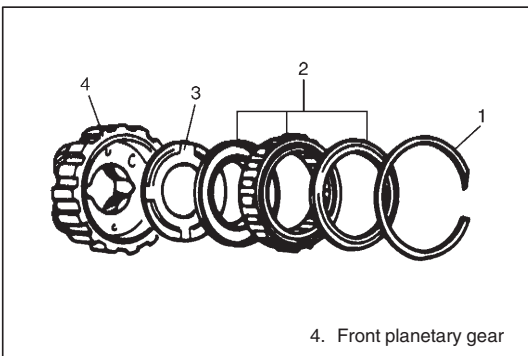

4) After removing retaining ring (1), remove one-way clutch (2) and one-way clutch rear thrust washer (3).

4. Front planetary gear

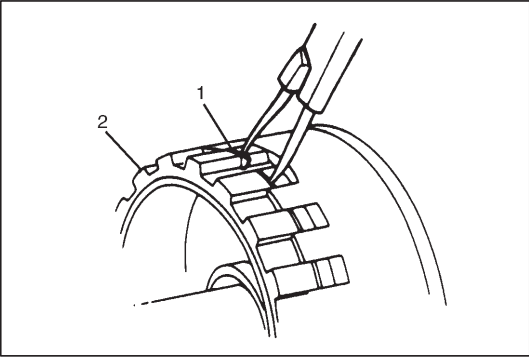

- 5) After removing retaining ring (1), remove front planetary ring gear (2), thrust bearing and rear planetary race.

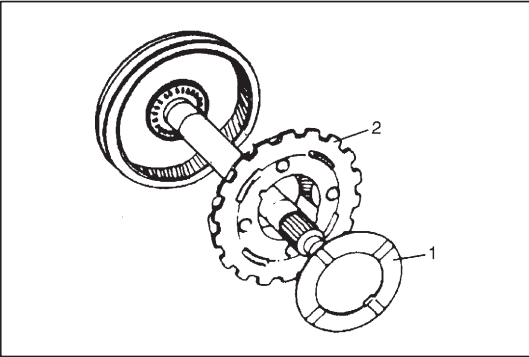

- 6) Remove rear planetary thrust washer (1), rear planetary gear (2).

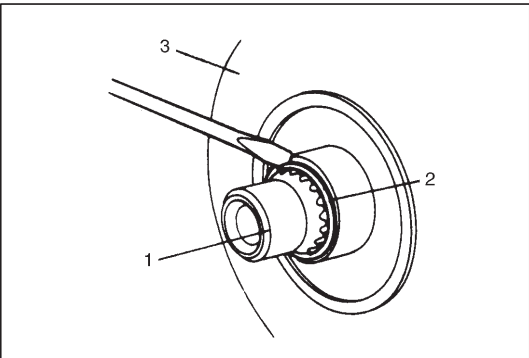

- 7) After removing retaining ring (2) from inner shaft (1), remove rear planetary ring gear (3) and thrust bearing assembly.

ASSEMBLY

Assemble components by reversing disassembly procedure and noting following points.

- Refer to the first figure of "PLANETARY GEARS AND OUTPUT SHAFT" when installing each component.
- Check seal sleeve ring for damage before installation and replace if damaged.
- Fit retaining rings into groove securely.

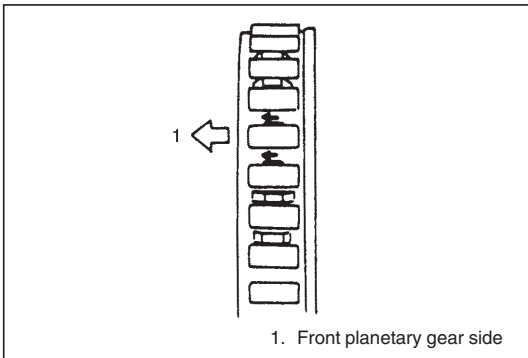

- Install one-way clutch as shown in the figure.

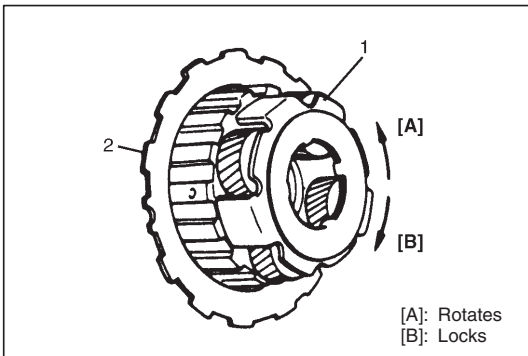

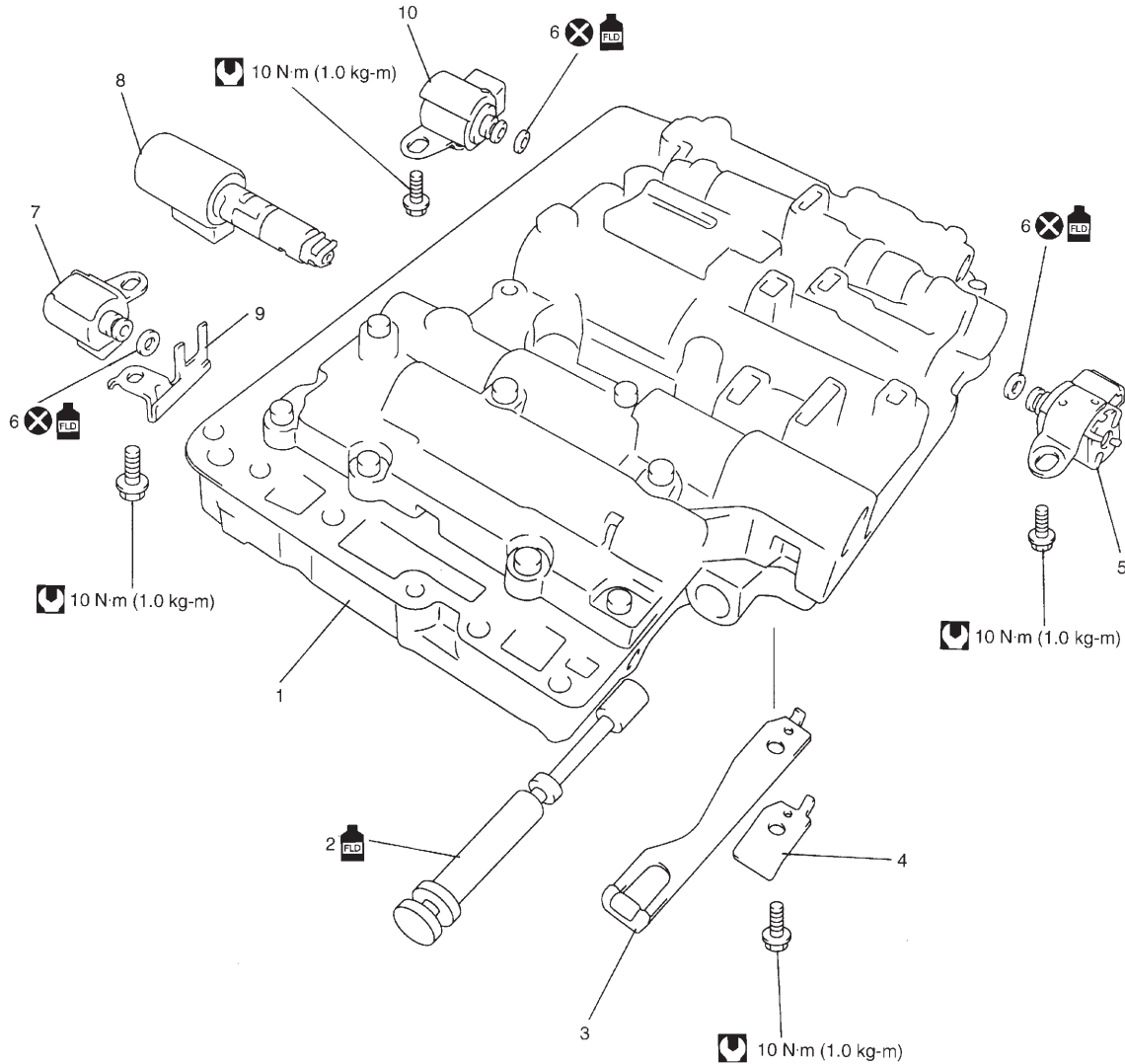

- Install reverse brake reaction plate (2) to front planetary gear (1). With reverse brake reaction plate (2) fixed stationary, turn front planetary gear (1) clockwise to check that it locks and then counterclockwise to check that it turns smoothly.

VALVE BODY ASSEMBLY



1. Valve body assembly
2. Manual valve
3. Detent spring
4. Detent spring cover
5. Shift solenoid-B (No.2) valve
6. O-ring
7. TCC (lock-up) solenoid valve
8. Pressure control solenoid valve
9. Clamp
10. Shift solenoid-A (No.1) valve

-  : Apply automatic transmission fluid.
-  : Tightening torque.
-  : Do not reuse.

CAUTION:

When replacing pressure control solenoid valve (8), it is strictly required to replace it together with valve body assembly (1) as a set.

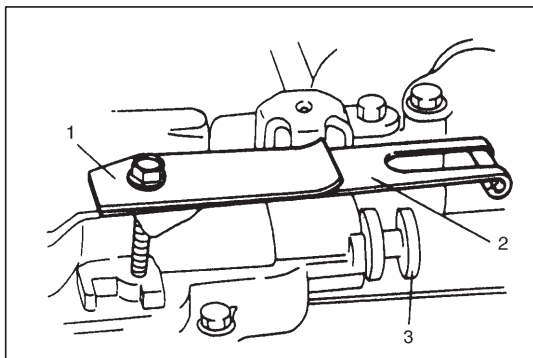

DISASSEMBLY

1) Remove detent spring (2), plate (1) and manual valve (3).

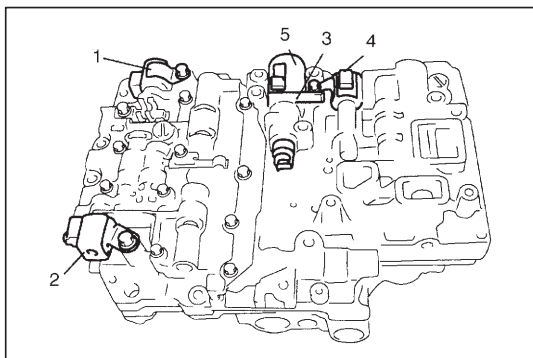

2) Remove shift solenoid-A valve (1) and shift solenoid-B valve (2).
 3) Remove clamp (3), then remove TCC solenoid valve (4) and Pressure control solenoid valve (5).

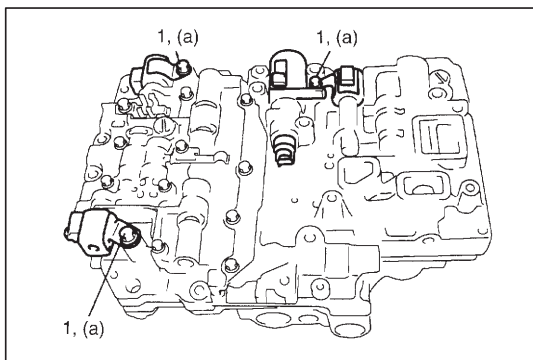

ASSEMBLY

Reverse disassembling procedure noting the following points.

- Use new O-ring for shift solenoid valves and TCC solenoid valve.
- Tighten solenoid bolts (1) to specified torque.

Tightening torque

Solenoid valve bolts (a): 10 N·m (1.0 kg-m, 7.5 lb-ft)

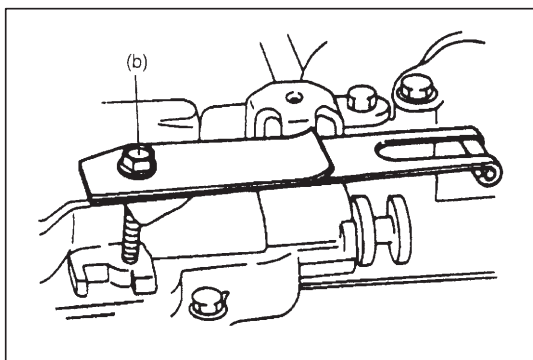

- Tighten detent spring bolt to specified torque.

Tightening torque

Detent spring bolt (b): 10 N·m (0.1 kg-m, 7.5 lb-ft)

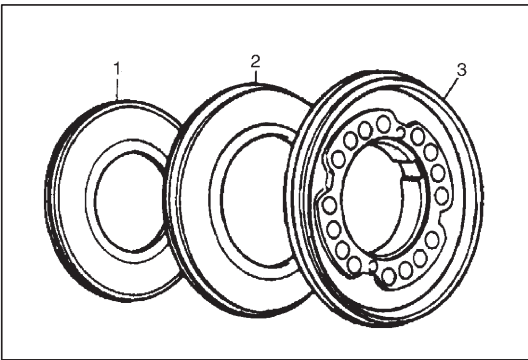

UNIT ASSEMBLY

1) After applying A/T fluid to new O-rings, install them to reverse brake piston (3), reaction sleeve (2) and secondary reverse piston (1).

2) install reverse brake piston assembly and brake piston return spring to transmission case, using care not to damage O-ring. Then install snap ring (1) with special tool.

Special tool

(A): 09926-98320

(B): 09941-84510

NOTE:

- Install so that opening in snap ring (1) will not align with any of 3 lugs of spring seat.
- Do not compress spring more than necessary and do not allow it fall or tilt.

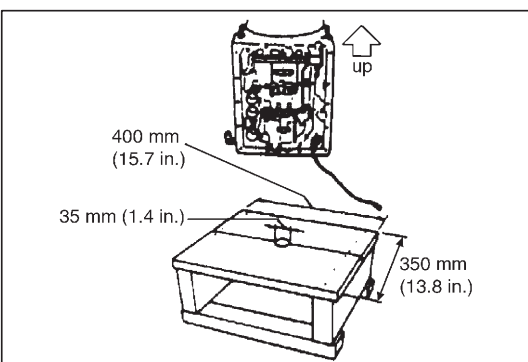
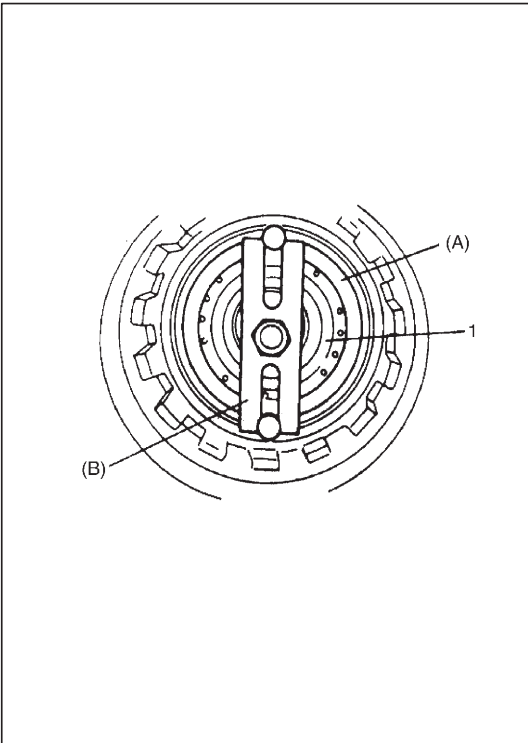

3) Prepare a stand as shown in the figure. It is necessary because work will be done with transmission case set upright from this step on.

NOTE:

- To protect transmission case against damage, spread cloth on stand where case contacts.
- A stand of such size as shown in figure will facilitate work.

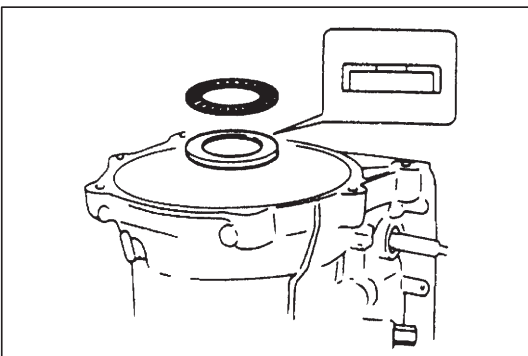

4) Install thrust output shaft bearing and thrust bearing output shaft race after lubricating them with grease.

NOTE:

- Make sure that thrust bearing output shaft race is installed in proper direction.

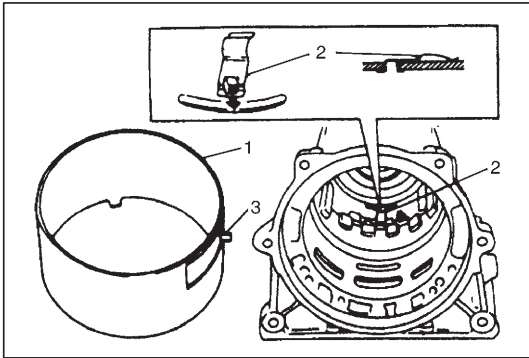

5) Install brake applying tube (1) so that its lug fits in a in transmission case. After installation, check that 4 lugs (3) along the underside of brake applying tube fit inside of reverse brake piston and leaf spring (2) is installed properly.

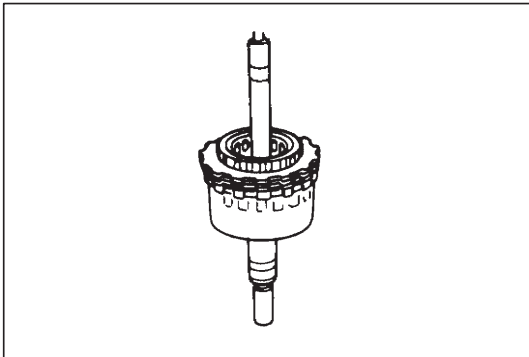

6) Remove reverse brake reaction plate of planetary gear assembly and align lugs of reverse brake plate, reverse brake disc and reverse brake packing plate. Install planetary gear assembly to transmission case so that aligned lugs fit in groove in transmission case.

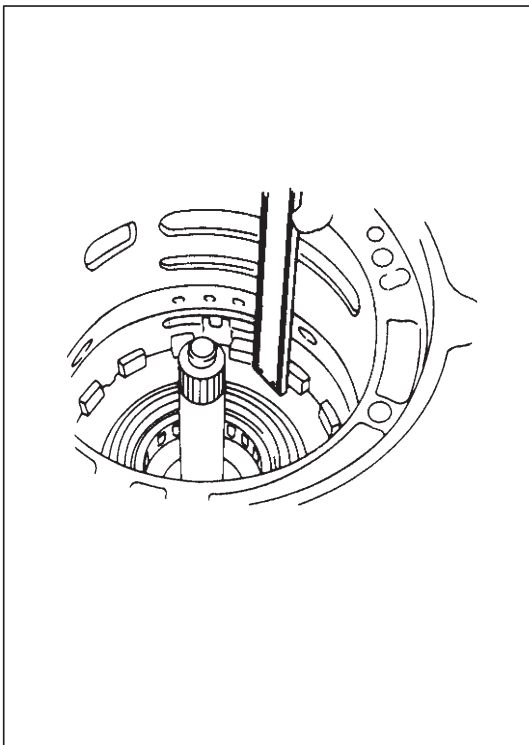

7) Measure clearance between reverse brake plate and lugs of transmission case.

If measured value is less than standard range, it is possible that something is installed improperly or dust or fluid is on reverse brake disc, etc. If it exceeds standard range, adjust it to standard clearance with selective reverse brake backing plates shown below.

Standard clearance between reverse brake plate and lugs of transmission case:

0.52 – 1.27 mm (0.02 – 0.05 in.)

Available plate thickness	3.25, 3.5, 3.75, 4.0, 4.25, 7.66 mm (0.128, 0.138, 0.148, 0.157, 0.167, 0.302 in.)
---------------------------	---

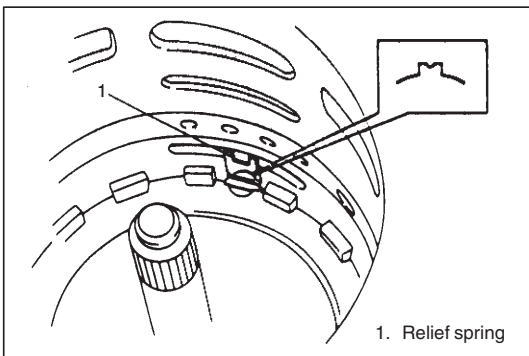

8) Install reverse brake reaction plate so that its lug with dent comes to the same position as leaf spring.

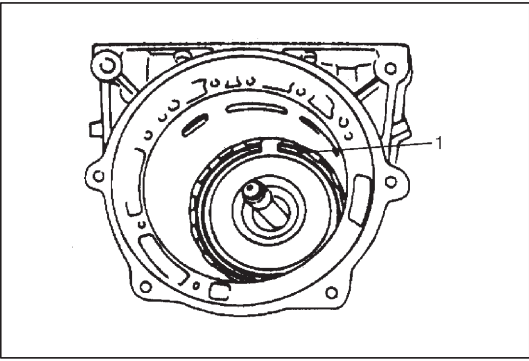

- 9) Using screwdriver with vinyl tape or the like wound at its tip, install retaining reaction plate ring (1). After installation, check that ring is in groove securely.

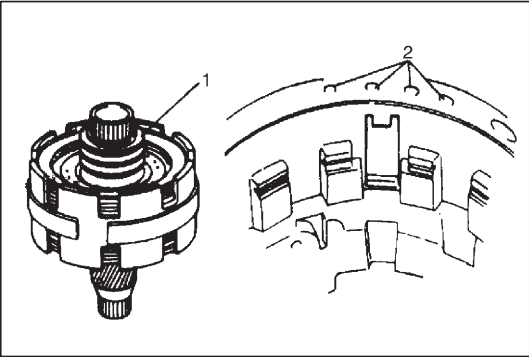

- 10) After confirming that lugs of all brake plates and brake discs are in grooves securely, hold retaining direct clutch ring (1) of planetary sun gear, install center support assembly by aligning fluid holes (2) in center support and transmission case.

NOTE:

Unless retaining direct clutch ring of planetary sun gear is held, brake valve gets off center support and that will make it impossible to align fluid holes with bolt holes.

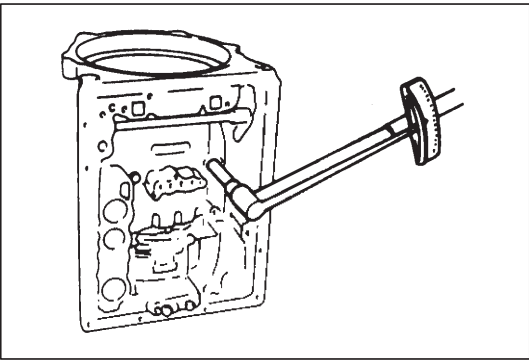

- 11) Tighten center support bolts by certain amount at a time till specified tightening torque is obtained.

Tightening torque

Center support bolts: 26 N·m (2.6 kg-m, 19.0 lb-ft)

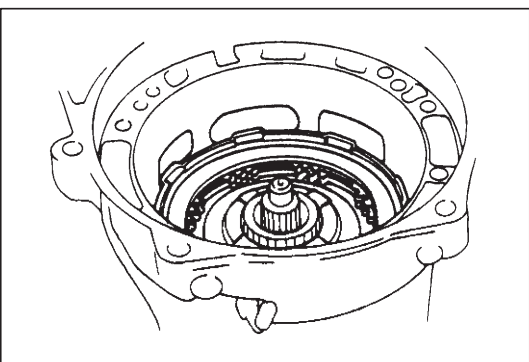

- 12) Install direct clutch assembly by aligning splines in direct clutch cylinder with planetary sun gear.

NOTE:

Ends of splines in direct clutch cylinder and planetary sun gear should come almost in match.

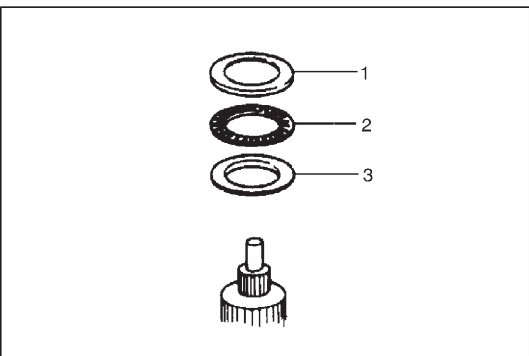

- 13) Apply grease to forward clutch rear No.1 race (1), thrust rear bearing (2), thrust bearing rear planetary ring race (3) and install thrust bearing planetary ring race (3) to direct clutch cylinder and forward clutch rear No.1 race and thrust bearing to forward clutch hub.

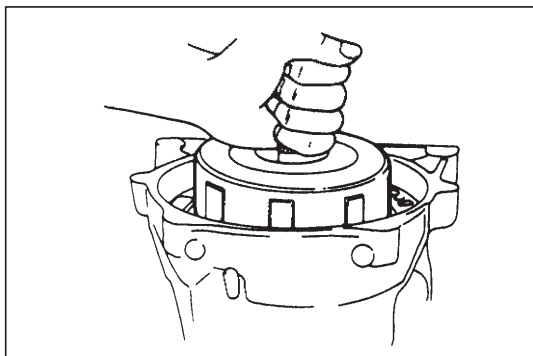

- 14) Install forward clutch assembly by putting all lugs of direct clutch disc hub together and matching them with groove cut in direct clutch input hub, and at the same time aligning splines in forward clutch hub with inner shaft.

NOTE:

Use care not to let forward clutch rear No.1 race and thrust bearing installed to forward clutch hub fall off.

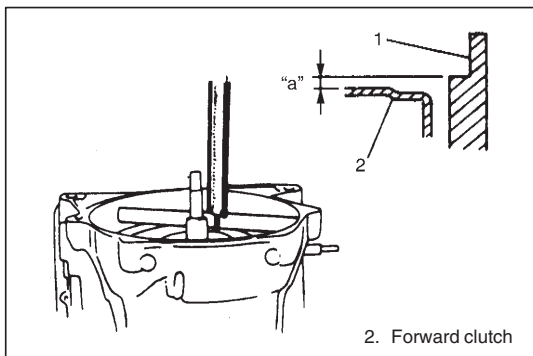

- 15) When clutch disc and plate have been replaced, check height difference between forward clutch input shaft and transmission case (1) by measuring as shown in the figure.

Standard height difference "a":

About 2.0 mm (0.079 in.)

NOTE:

If measured value is less than standard value, remove forward clutch assembly and install it again.

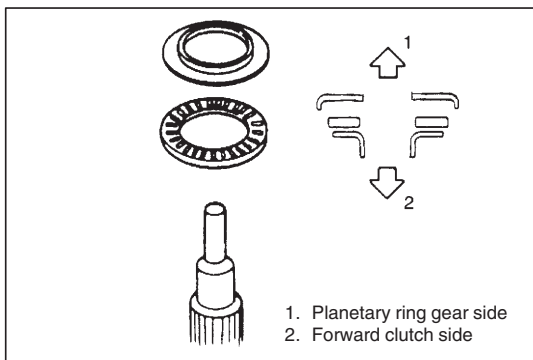

- 16) Apply grease to thrust forward clutch bearing and install it to forward clutch input shaft. Also apply grease to thrust rear race and install it to O/D case.

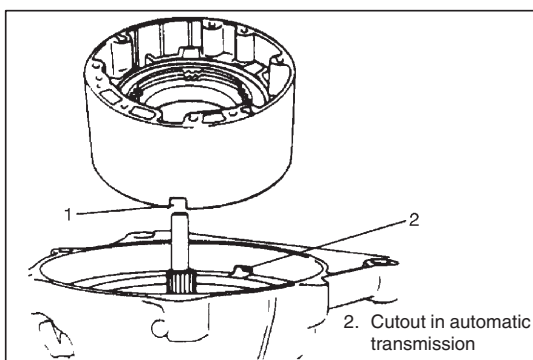

- 17) Install O/D case by aligning cutout in O/D case (1) and that in transmission case.

NOTE:

Use care not to drop thrust rear race installed to O/D case.

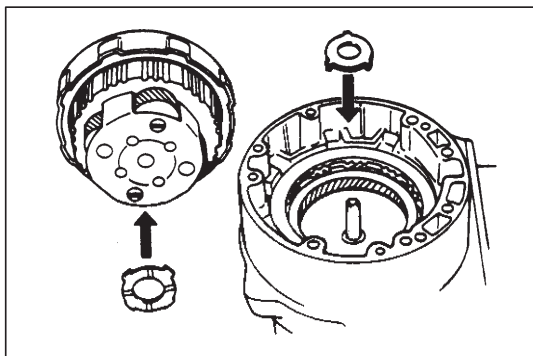

- 18) Apply grease to thrust planetary rear washer and install it to O/D planetary gear. Also apply grease to thrust planetary ring front race and install it to planetary ring gear and then install O/D input shaft assembly to O/D case.

NOTE:

- **Fit claws of thrust planetary rear washer and thrust planetary ring front race into holes securely.**
- **Use care not to drop thrust planetary rear washer installed to O/D planetary gear.**

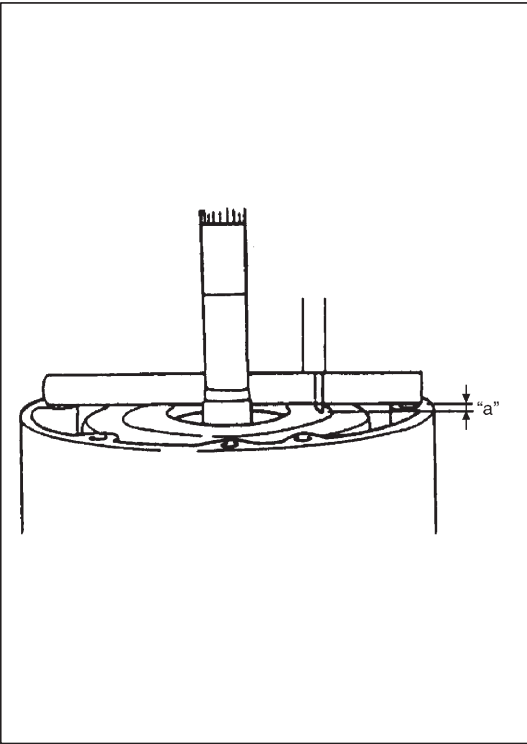

- 19) When clutch disc or plate has been replaced, check height difference between O/D case and O/D clutch cylinder by measuring it as shown in the figure.

Standard height difference "a" between O/D case and O/D clutch cylinder:

About 3.5 mm (0.138 in.)

NOTE:

Measure at the highest point along inner circumference of O/D clutch cylinder.

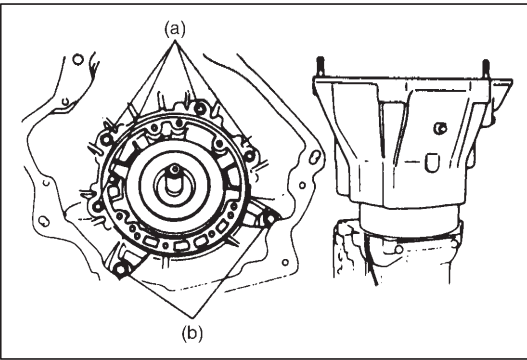

- 20) Apply A/T fluid to new housing O-ring and install it to O/D case. Then install converter housing and tighten housing bolt to specified torque.

Tightening torque

Torque converter housing No.1 bolts (a):

35 N·m (3.5 kg-m, 25.5 lb-ft)

Torque converter housing No.2 bolts (b):

58 N·m (5.8 kg-m, 42.0 lb-ft)

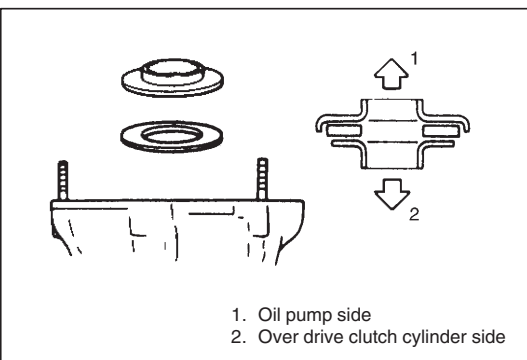

- 21) Apply grease to thrust front race and install it to O/D clutch cylinder.

1. Oil pump side
2. Over drive clutch cylinder side

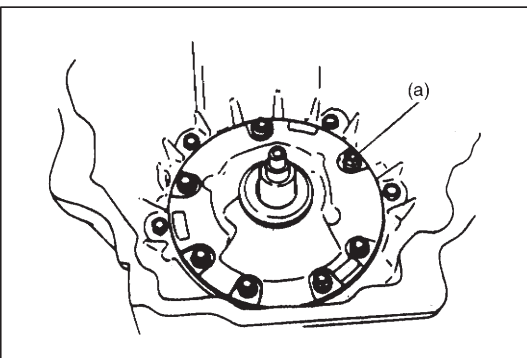

- 22) Apply grease to front bearing assembly and install it to oil pump assembly. Also, apply A/T fluid to new oil pump cover O-ring and install it to oil pump assembly. Then install oil pump assembly aligning bolt holes in O/D case with those in transmission case oil pump assembly. Apply seal packing to oil pump assembly bolts and tighten them by certain amount of torque at each time one after another till specified torque is attained.

Tightening torque

Oil pump assembly bolt (a): 22 N·m (2.2 kg-m, 16.0 lb-ft)

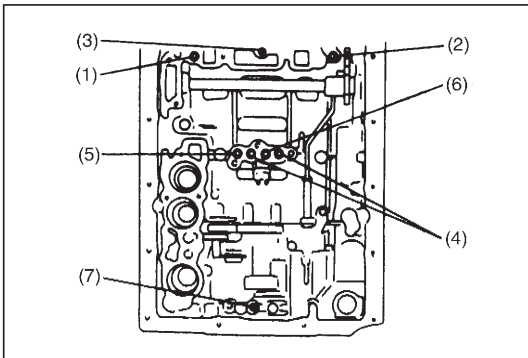

23) Apply 2 – 4 kg/cm² air pressure into fluid holes in the figure as numbered and check operation sound of each part.

- (1) O/D clutch
- (2) O/D brake
- (3) Forward clutch
- (4) Direct clutch
- (5) Second coast brake
- (6) Second brake
- (7) Reverse brake

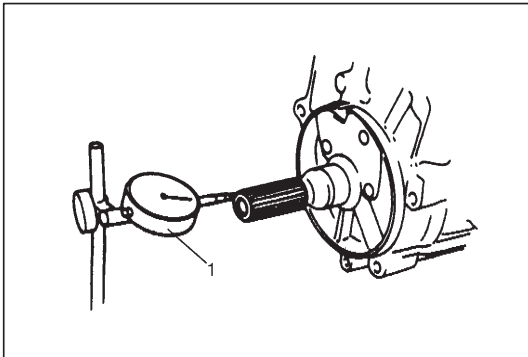

24) Take down transmission from stand and measure clearance in shaft direction by applying dial gauge (1) to output shaft as shown in the figure.

**Standard clearance in shaft direction:
0.3 – 0.9 mm (0.012 – 0.035 in.)**

25) Check that inner shaft runs smoothly.

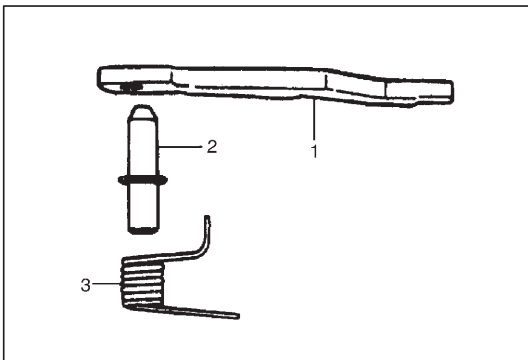

26) Install parking lock pawl (1), pawl pin (2) and pawl spring (3) to transmission case.

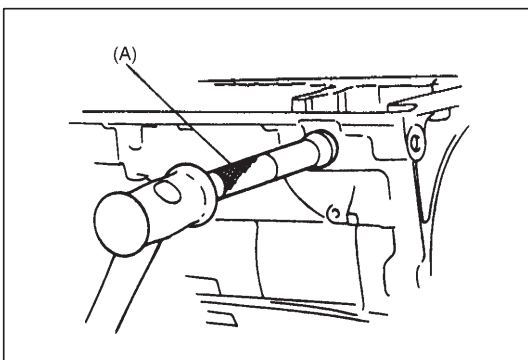

27) Apply grease to lip of new oil lip seal and drive in oil lip seal with special tool till it contacts transmission case.

**Special tool
(A): 09943-88211**

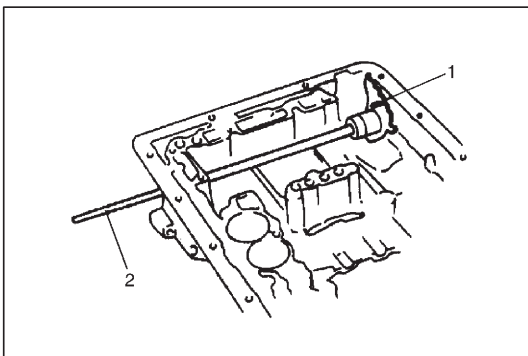

28) After installing new sleeve cover to manual shift lever (1), install manual shift shaft (2) and manual shift lever (1) to transmission case.

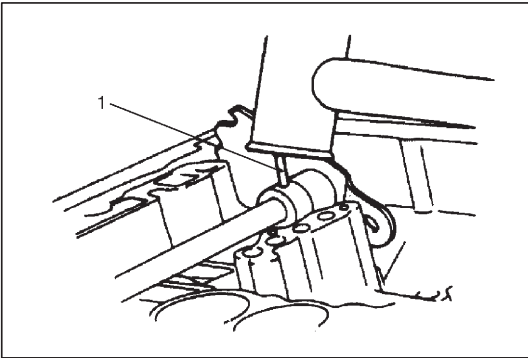

29) Align hole in manual shift shaft with that in manual shift lever and drive in new manual shift lever pin (1).

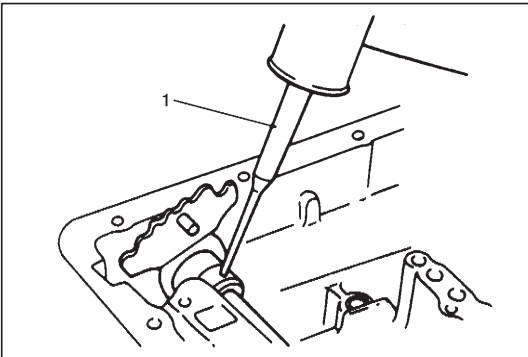

30) Align hole in sleeve cover with dent in manual shift lever and caulk securely with pin punch (1). Then check that manual shift shaft turns smoothly.

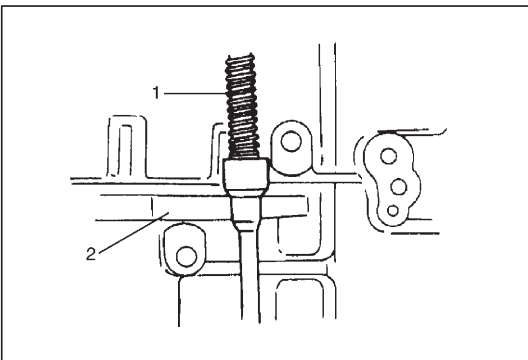

31) With parking lock rod (1) installed to manual shift lever, place parking lock rod (1) on parking lock pawl (2) as shown in the figure. Then install pawl bracket and tighten bracket screw to specified torque.

Tightening torque

Pawl bracket screw: 7.5 N·m (0.75 kg·m, 5.5 lb-ft)

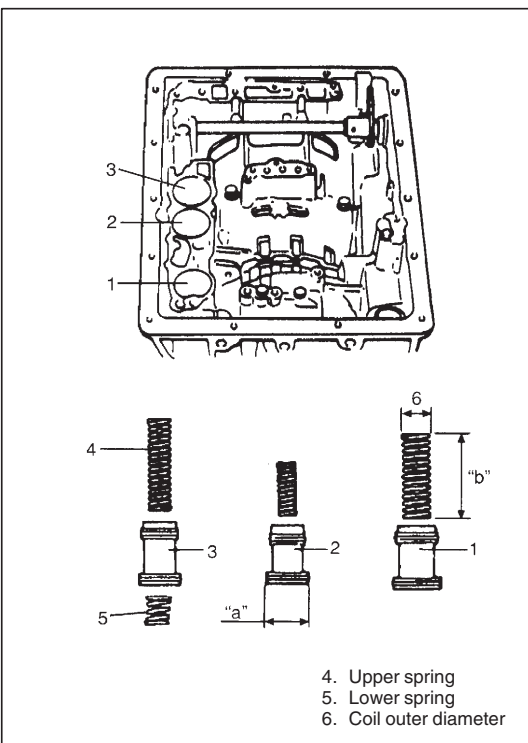

32) Apply A/T fluid to new O-rings and install them to accumulator pistons (1, 2, 3) and install accumulator pistons to transmission case.

Accumulator piston and spring specification:

Used for	Piston outer diameter "a"	Spring free length "b"		Identification painting
		Upper spring	Lower spring	
Direct clutch accumulator (2)	31.80 – 31.85 mm (1.252 – 1.254 in.)	Upper spring	58.96 mm (2.321 in.)	Light blue
		Lower spring	–	–
Forward clutch accumulator (1)	31.80 – 31.85 mm (1.252 – 1.254 in.)	Upper spring	75.03 mm (2.954 in.)	White + blue
		Lower spring	–	–
Second brake accumulator (3)	34.80 – 34.85 mm (1.370 – 1.372 in.)	Upper spring	56.4 mm (2.220 in.)	Green
		Lower spring	18.5 mm (0.728 in.)	Light blue

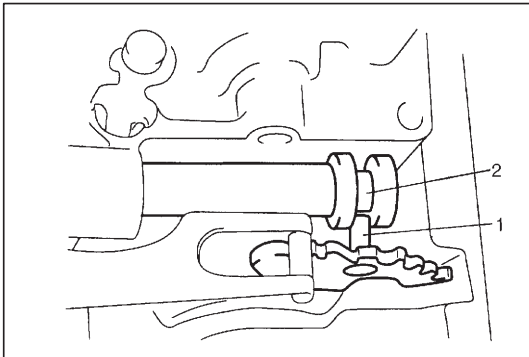

33) After confirming that accumulator piston is pushed all the way down, match pin (1) of manual shift lever with groove in manual valve (2).

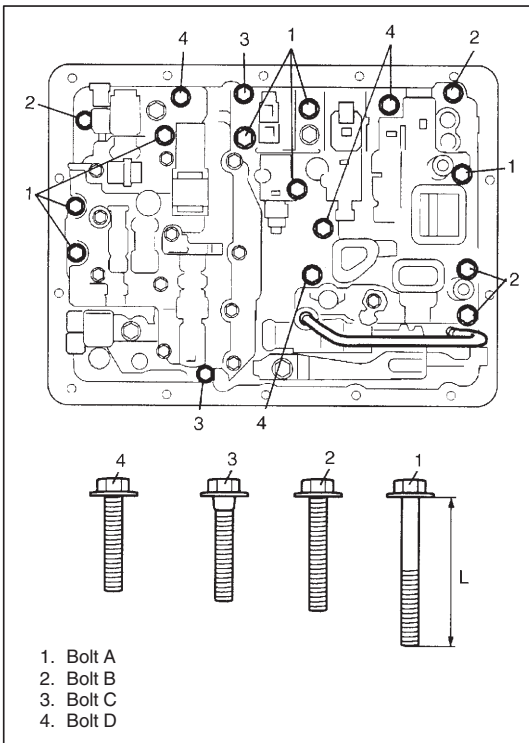

34) Install valve body assembly by using bolts noting its length shown below.

Tightening torque

Valve body bolts (a): 10 N·m (1.0 kg-m, 7.5 lb-ft)

Valve body bolt length

Bolt	Length	Pieces
A	45 mm (1.77 in.)	7
B	36 mm (1.42 in.)	4
C	30 mm (1.22 in.)	2
D	28 mm (1.10 in.)	4

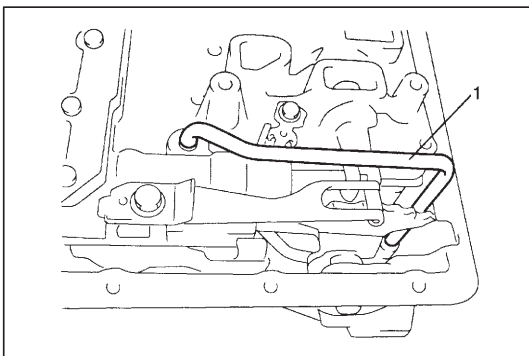

35) Using plastic hammer, install oil pipe (1).

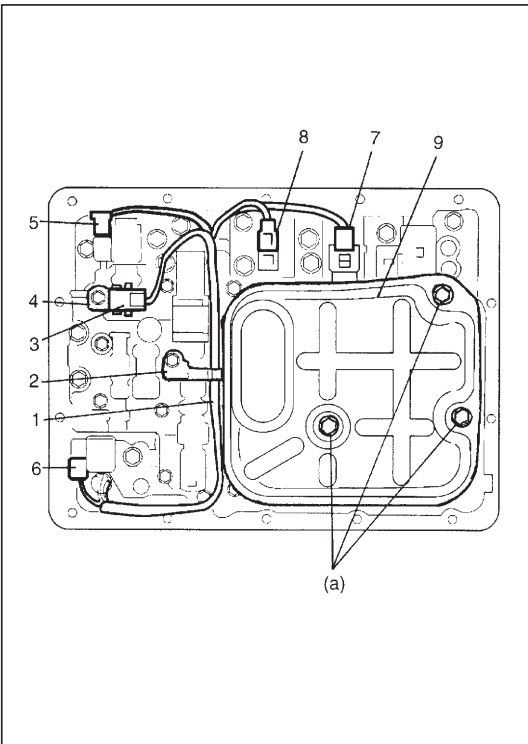

- 36) Clamp wire harness (1) by wire harness clamp (2).
- 37) Install transmission temperature sensor (3) to sensor clamp (4).
- 38) Connect the following connector by referring to its color shown below.
 - Shift solenoid-A (No.1) connector (5) – Brown
 - Shift solenoid-B (No.2) connector (6) – Black
 - TCC (lock up) solenoid connector (7) – White
 - Pressure control solenoid connector (8) – Black
- 39) Install oil strainer (9).

Tightening torque

Oil strainer bolts (a): 10 N·m (0.1 kg-m, 7.5 lb-ft)

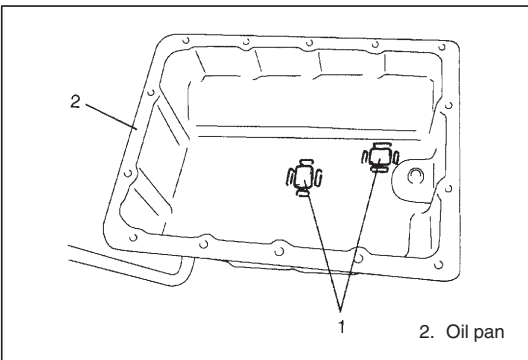

- 40) Confirm two oil pan magnet (1) are in its place.

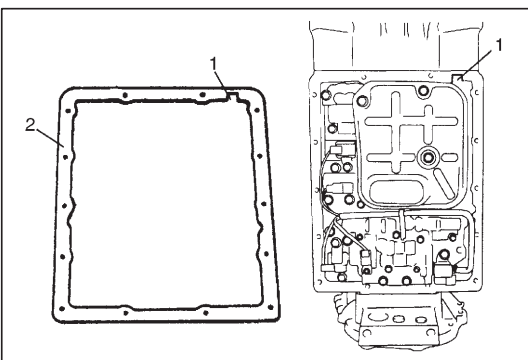

- 41) Install transmission oil pan with new oil pan gasket (2).

NOTE:

Align cut out (1) in oil pan gasket with that in transmission case.

Tightening torque

**Transmission oil pan bolts:
4.5 N·m (0.45 kg-m, 3.5 lb-ft)**

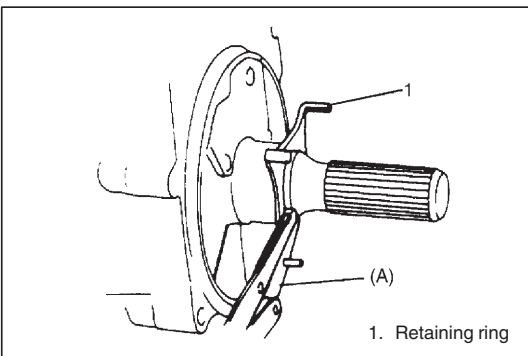

- 42) With wood rough key attached to output shaft, install sensor rotor by aligning its key groove with wood rough key and install C-ring by using special tool.

Special tool

(A): 09920-76010

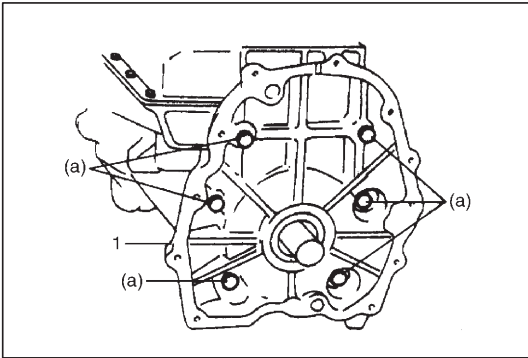

- 43) Install adapter case (1) with new adapter gasket to transmission case and tighten adapter case bolts to specified torque.

Tightening torque

Adapter case bolt (a): 35 N·m (3.5 kg-m, 25.5 lb-ft)

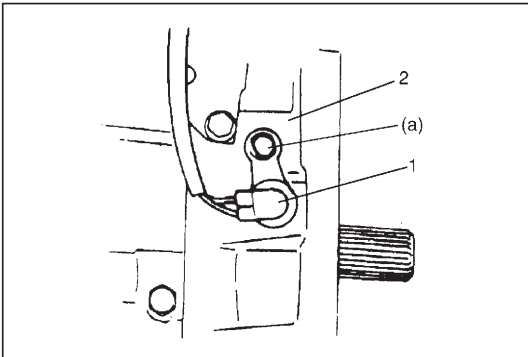

- 44) Apply A/T fluid to new O-ring and install it to output shaft speed sensor (1) and then install output shaft speed sensor (1) to adapter case (2).

Tightening torque

**Output shaft speed sensor bolt (a):
7.5 N·m (0.75 kg-m, 5.5 lb-ft)**

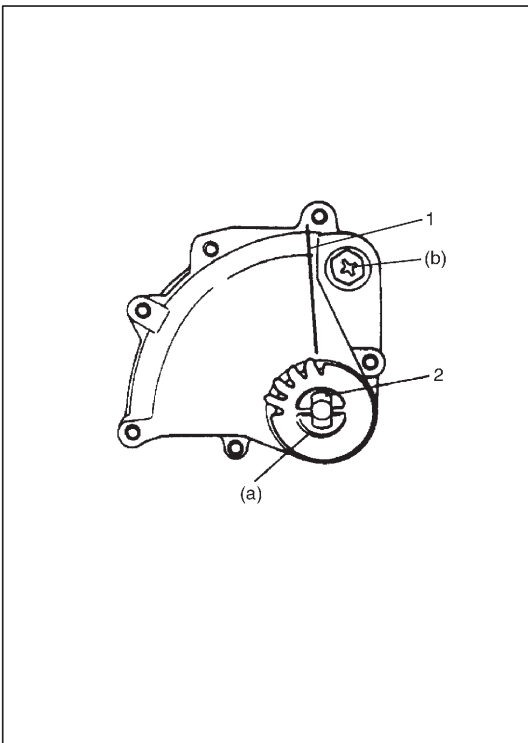

- 45) After turning manual shift shaft fully rearward, turn it back by 2 notches and set it to "N" range. Then install transmission range sensor, lock washer and set nut and tighten set nut. After tightening it, bend claws of lock washer.

Tightening torque

**Manual shift shaft set nut (a):
4 N·m (0.4 kg-m, 3.0 lb-ft)**

- 46) With neutral reference line (1) and cut groove (2) in sensor aligned, tighten lock bolt.

Tightening torque

**Transmission range sensor lock bolt (b):
5.5 N·m (0.55 kg-m, 4.0 lb-ft)**

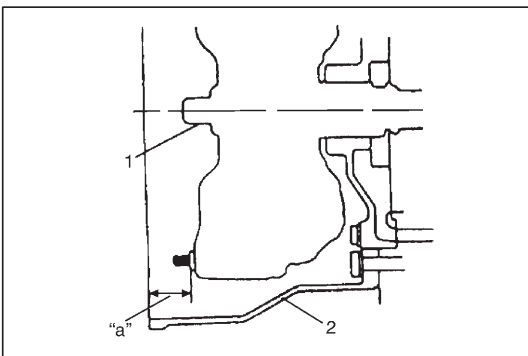

- 47) Confirm that torque converter is fully fitted in transmission. Confirmation can be done by measuring dimension between end surface of housing case (2) and drive plate installation seat.

**Standard dimension between end surface of case housing and drive plate installation seat "a":
56.4 mm (2.22 in.)**

- 48) Check that torque converter turns smoothly and apply grease to center piece (1) of torque converter.

BEARING AND RACE INSTALLATION DIAGRAM

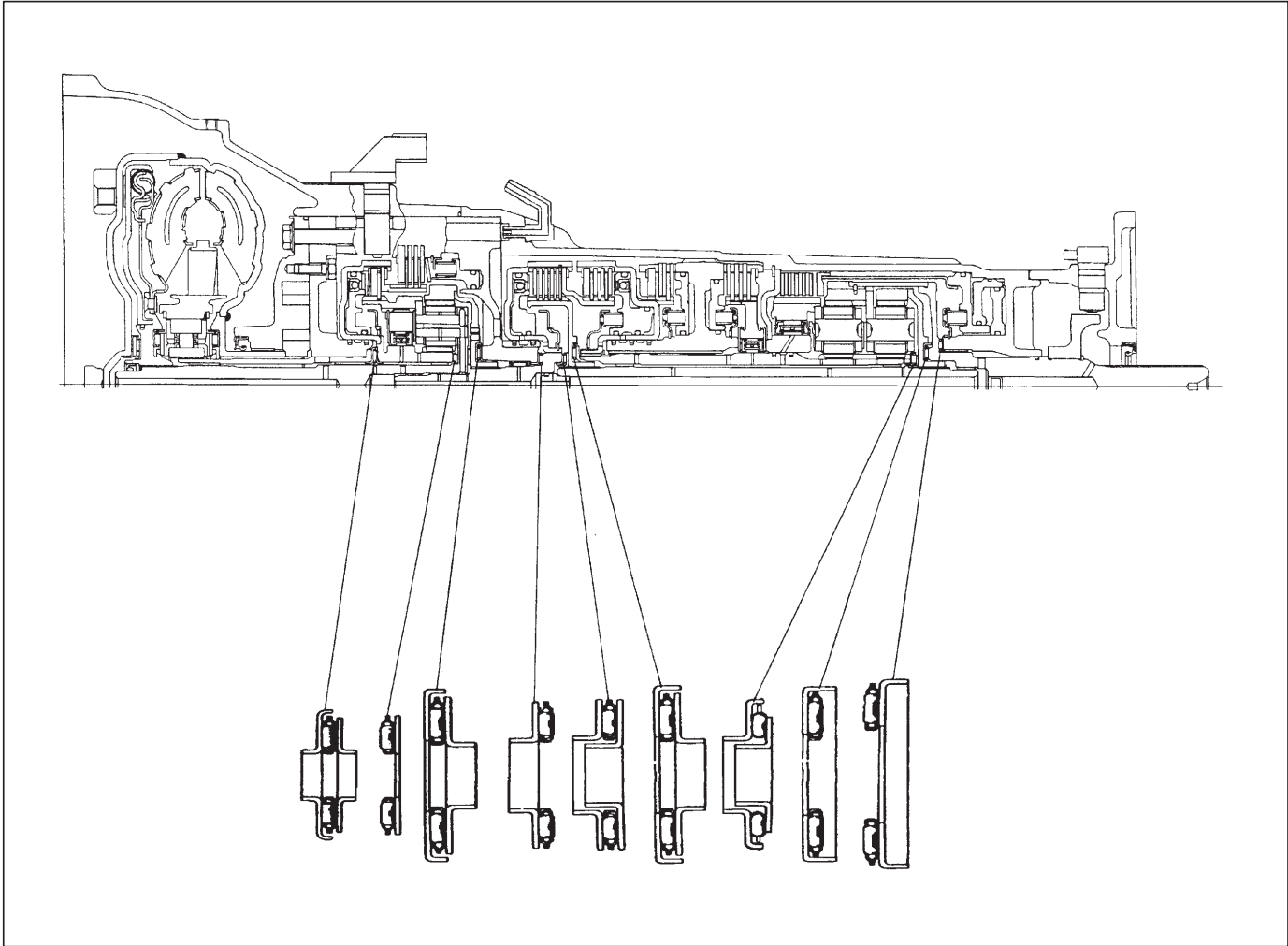

TIGHTENING TORQUE SPECIFICATION

Fastening part		Tightening torque		
		N·m	kg-m	lb-ft
Transmission case plug		7.5	0.75	5.5
A/T fluid drain plug		20	2.0	14.5
Transfer oil drain and level/filler plugs		23	2.3	17.0
Manual selector assembly bolts		18	1.8	13.5
Manual select lever nut		13	1.3	9.5
Manual select cable end nut		7	0.7	5.5
Transmission range sensor lock bolt		5.5	0.55	4.0
Oil cooler pipe union bolts	(For copper gasket)	35	3.5	25.5
	(For rubber coated gasket)	25	2.5	18.0
Oil cooler pipe clamp bolt		10	1.0	7.5
Torque converter mounting bolts		65	6.5	47.0
Transmission to engine bolts and nuts		61	6.1	44.0
Drive plate bolts		50	5.0	36.5
Engine rear mounting bolts		50	5.0	36.5
Engine rear mounting member bolts		50	5.0	36.5
Exhaust No.1 pipe to manifold nuts		50	5.0	36.5
Exhaust No.2 pipe to No.1 pipe bolts		50	5.0	36.5
Muffler to exhaust No.2 pipe nuts		60	6.0	43.5
Front propeller shaft universal joint flange bolts		50	5.0	36.5
Rear propeller shaft universal joint flange bolts		60	6.0	43.5
Oil filler tube bolt		23	2.3	17.0
Stabilizer bar mount bush bracket bolts		23	2.3	17.0
Select cable bracket bolts		23	2.3	17.0
Oil pump bolts		7.5	0.75	5.5
Solenoid valve bolts		10	1.0	7.5
Detent spring bolt		10	1.0	7.5
Center support bolts		26	2.6	19.0
Torque converter housing No.1 bolts		35	3.5	25.5
Torque converter housing No.2 bolts		58	5.8	42.0
Oil pump assembly bolts		22	2.2	16.0
Pawl bracket screw		7.5	0.75	5.5
Valve body bolts		10	1.0	7.5
Oil strainer bolts		10	1.0	7.5
Transmission oil pan bolts		4.5	0.45	3.5
Adapter case bolts		35	3.5	25.5
Output shaft speed sensor bolt		7.5	0.75	5.5
Manual shift shaft set nut		4	0.4	3.0

REQUIRED SERVICE MATERIAL

Material	Recommended SUZUKI product (Part Number)	Use
A/T fluid	Refer to Section 0B	<ul style="list-style-type: none"> ● Automatic transmission ● Parts lubrication when installing ● Solenoid valve O-ring
Lithium grease	SUZUKI SUPER GREASE C (99000-25030)	<ul style="list-style-type: none"> ● Retaining parts in place when assembling ● Oil seal lips ● Oil pump O-ring
	SUZUKI SUPER GREASE A (99000-25010)	Cable ends

SPECIAL TOOL

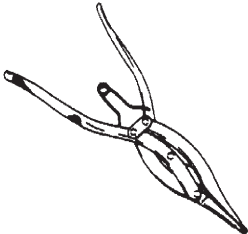
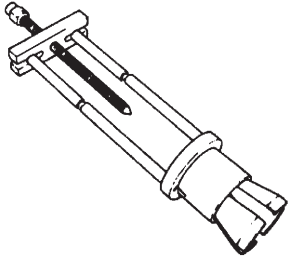
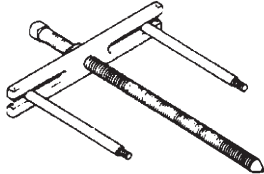
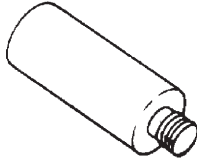
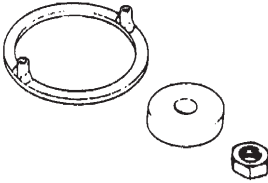
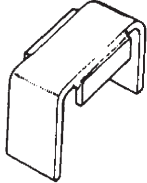
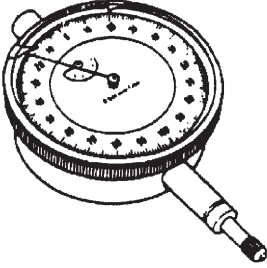
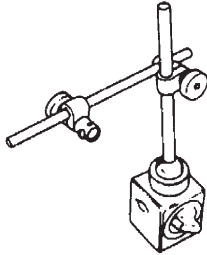
			
09920-76010 Snap ring opener	09941-84510 Bearing inner race remover	09918-48211 Oil pump remover	09918-48220 Oil pump remover attachment (M8)
			
09926-98320 Spring compressor No.1 set	09926-98310 Clutch spring compressor	09900-20606 Dial gauge	09900-20701 Magnetic stand

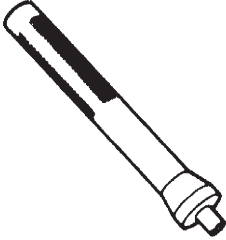
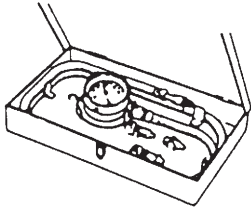
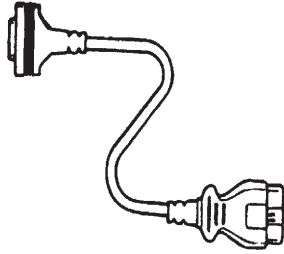
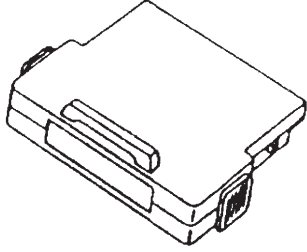
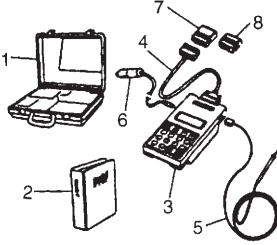
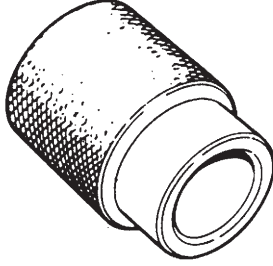
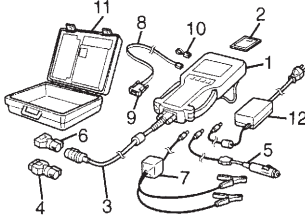
 <p>09943-88211 Bearing installer</p>	 <p>09925-37811-001 Oil pressure gauge</p>	 <p>09931-76030 16/14 pin DLC</p>	 <p>Mass storage cartridge of version 1.7 or more for Tech 1A.</p>
 <p>09931-76011 Tech 1A kit (SUZUKI scan tool) See NOTE "A" below.</p>	 <p>09940-53111 Bearing installer</p>	 <p>Tech 2 kit (SUZUKI scan tool) See NOTE "B" below.</p>	

NOTE:

- "A" : This kit includes the following items and substitutes for the Tech 2 kit.
 1. Storage case, 2. Operator's manual, 3. Tech 1A, 4. DLC cable, 5. Test lead/probe, 6. Power source cable, 7. DLC cable adaptor, 8. Self-test adaptor
- "B" : This kit includes the following items and substitutes for the Tech 1 kit.
 1. Tech 2, 2. PCMCIA card, 3. DLC cable, 4. SAE16/19 adapter, 5. Cigarette cable, 6. DLC loopback adapter, 7. Battery power cable, 8. RS232 cable, 9. RS232 adapter, 10. RS232 loopback connector, 11. Storage case, 12. Power supply

SECTION 7C1

CLUTCH

NOTE:

For the descriptions (items) not found in this section, refer to the same section of the Service Manual mentioned in the FOREWORD of this manual.

CONTENTS

GENERAL DESCRIPTION	7C1-2
UNIT REPAIR	7C1-3
CLUTCH COVER, CLUTCH DISC AND FLYWHEEL	7C1-3
TIGHTENING TORQUE SPECIFICATION	7C1-7
REQUIRED SERVICE MATERIAL	7C1-7
SPECIAL TOOL	7C1-7

GENERAL DESCRIPTION

The clutch is a diaphragm-spring type clutch with a dry single disc. The diaphragm spring is of a tapering-finger type, which a solid ring is set in the outer diameter part, with a series of tapered fingers pointing inward.

The clutch disc, which is positioned on the transmission input shaft with an involute spline fit, is a type called silent type. The silent type clutch disc is provided with the performance of absorbing the engine output torque fluctuation, which is peculiar to the diesel engine. This performance of the silent type clutch disc is attained from the characteristics which can vary torsional torque as two step depending on its torsional angle and the specific hysteresis feature called AC/DC hysteresis.

The clutch cover is secured to the flywheel, and carries the diaphragm spring in such a way that the peripheral edge part of the spring pushes on the pressure plate against the flywheel (with the disc in between), when the clutch release bearing is held back. This is the engaged condition of the clutch.

Depressing the clutch pedal causes the release bearing to advance and pushes on the tips of the tapered fingers of the diaphragm spring. When this happens, the diaphragm spring pulls the pressure plate away from the flywheel, thereby interrupting the flow of drive from flywheel through clutch disc to transmission input shaft.

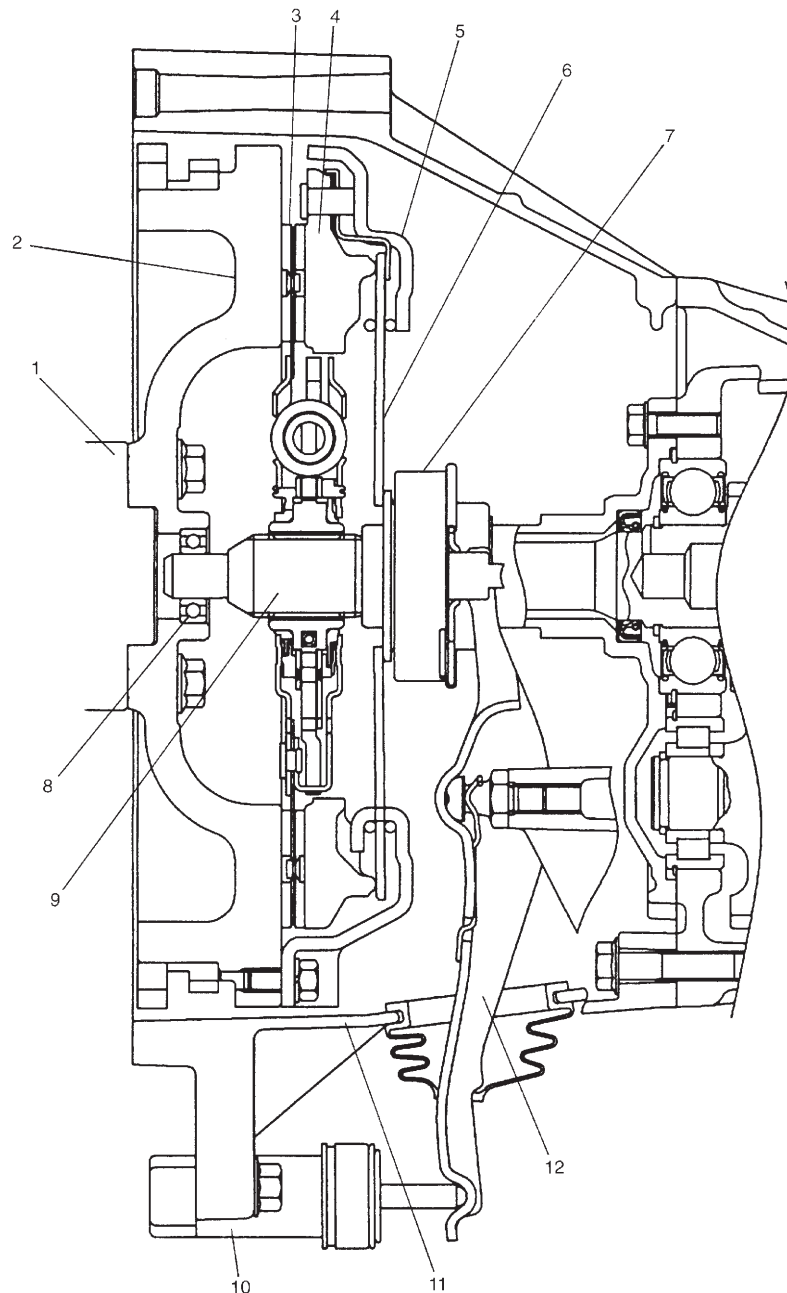

1. Crankshaft
2. Flywheel
3. Clutch disc
4. Pressure plate
5. Clutch cover
6. Diaphragm spring
7. Release bearing
8. Input shaft bearing
9. Input shaft
10. Operating cylinder
11. Clutch housing
12. Release fork

UNIT REPAIR

CLUTCH COVER, CLUTCH DISC AND FLYWHEEL

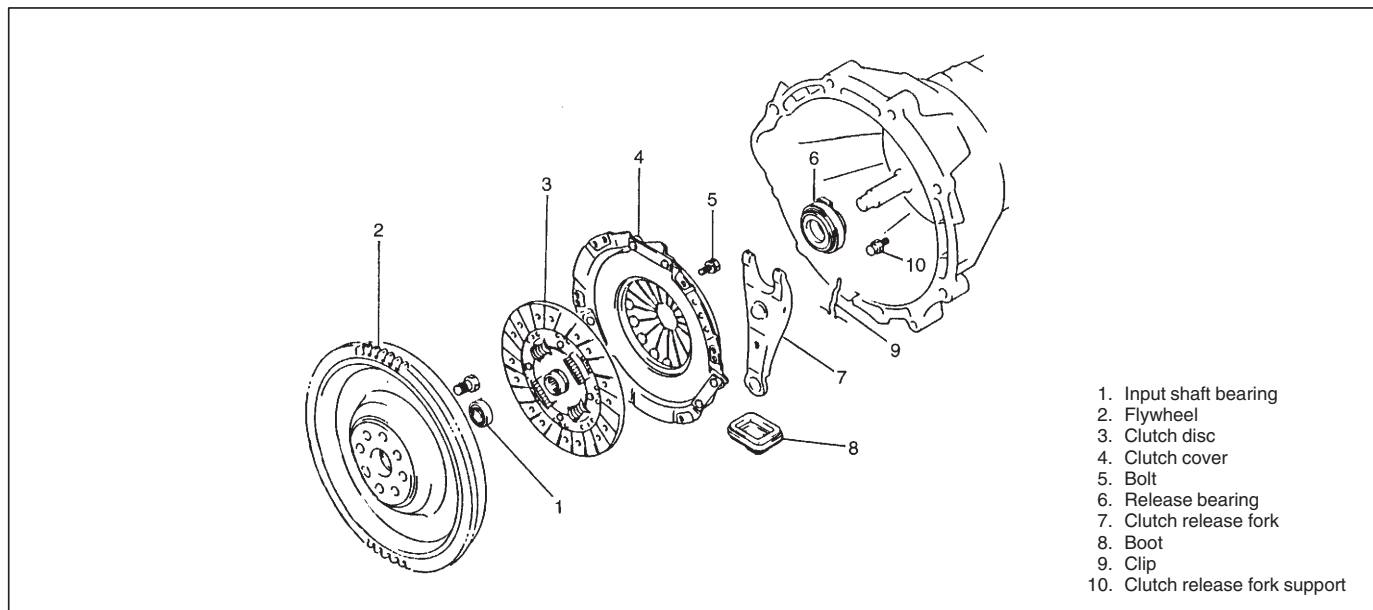

DISMOUNTING/REMountING

Refer to SECTION 7A2 "DISMOUNTING/REMountING OF TRANSMISSION".

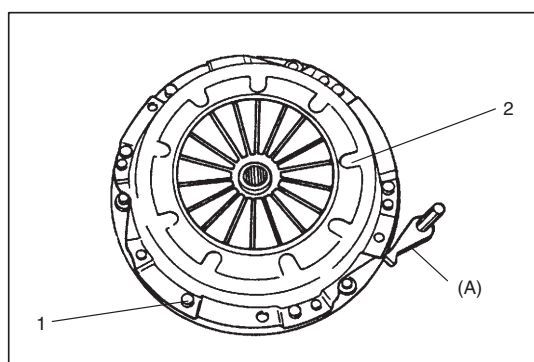

REMOVAL

- 1) Hold flywheel stationary with special tool and remove clutch cover bolts (1), clutch cover (2) and clutch disc.

Special Tool

(A): 09924-17811

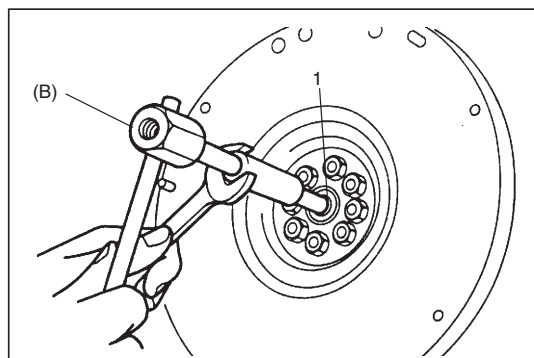

- 2) Pull out input shaft bearing (1) by using special tool and wrench.

Special Tool

(B): 09923-73210

- 3) Remove release bearing and release fork.

INSPECTION

Input Shaft Bearing and Release Bearing

Check bearing for smooth rotation and replace it if abnormality is found.

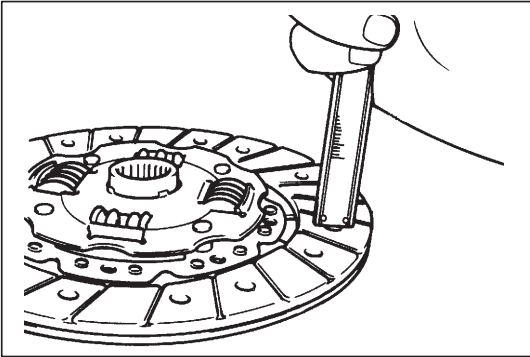

Clutch Disc

Measure depth of rivet head depression, i.e. distance between rivet head and facing surface. If depression is found to have reached service limit at any of holes, replace disc assembly.

Rivet head depth

Standard: 1.6 mm (0.06 in.)

Service limit: 0.5 mm (0.02 in.)

Clutch Cover

- 1) Check diaphragm spring for abnormal wear or damage.
- 2) Inspect pressure plate for wear or heat spots.
- 3) If abnormality is found, replace it as assembly. Do not disassemble it into diaphragm and pressure plate.

Flywheel

Check surface contacting clutch disc for abnormal wear or heat spots. Replace or repair as required.

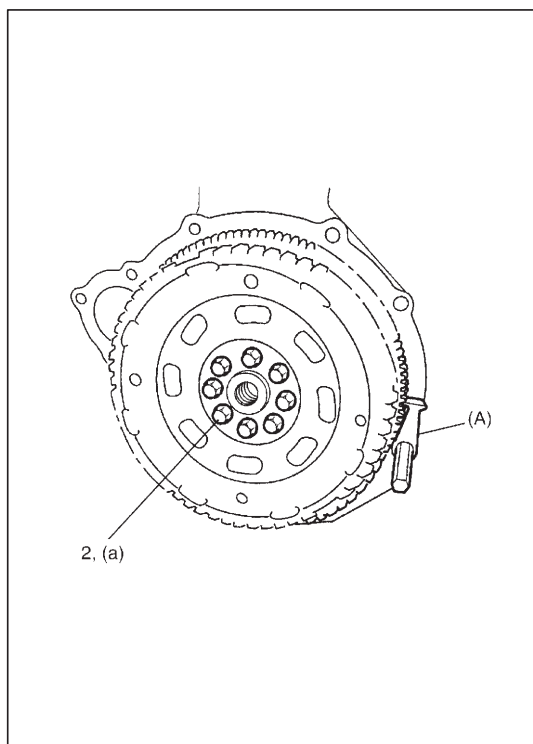

INSTALLATION

NOTE:

Before assembling, make sure that flywheel surface and pressure plate surface have been cleaned and dried thoroughly.

- 1) Install flywheel to crankshaft and tighten bolts (2) to specification.

Special Tool

(A): 09924-17811

Tightening Torque

(a): 50 N·m (5.0 kg-m, 36.5 lb-ft)

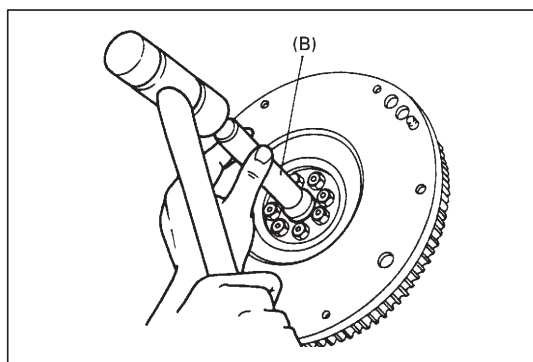

- 2) Using special tool, install input shaft bearing to flywheel.

Special Tool

(B): 09925-98210

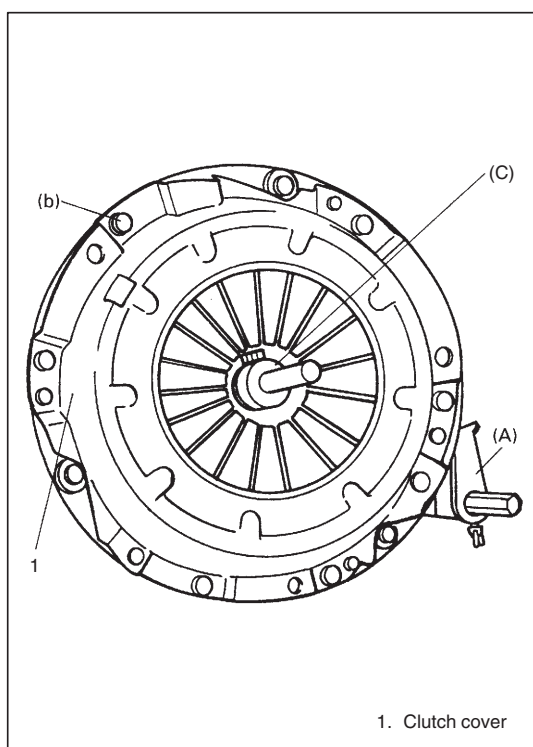

- 3) Aligning clutch disc to flywheel center by using special tool, install clutch cover and bolts. Then tighten bolts to specification.

NOTE:

- While tightening clutch cover bolts, compress clutch disc with special tool by hand so that disc centered.
- Tighten cover bolts little by little evenly in diagonal order.

Special Tools

(A): 09924-17811

(C): 09923-36320

Tightening Torque

(b): 23 N·m (2.3 kg-m, 16.5 lb-ft)

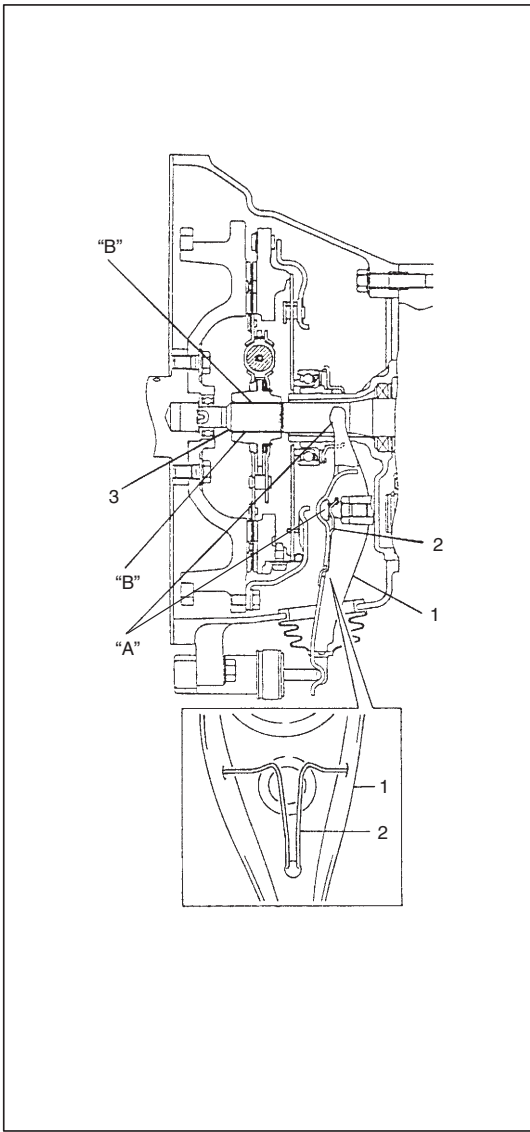

4) Install clip (2) to release fork (1) and apply grease.

“A”: Grease 99000-25010

Then install release fork (1) and release bearing as shown in figure.

5) Slightly apply grease to input shaft (3) and install clutch disc. Then join transmission transfer assembly with engine. Refer to Section 7A2.

“B”: Grease 99000-25210

NOTE:

Turn crankshaft with wrench from front while inserting transmission input shaft to clutch disc until splines mesh.

TIGHTENING TORQUE SPECIFICATION

Fastening portion	Tightening torque		
	N·m	kg·m	lb·ft
Clutch fluid pipe flare nut	16	1.6	11.5
Clutch master cylinder nut	13	1.3	9.5
Clevis lock nut	10	1.0	7.5
Flywheel bolts	50	5.0	36.5
Clutch cover bolts	23	2.3	16.5
Clutch operating cylinder bolt	50	5.0	36.5
Clutch hose union bolt	23	2.3	16.5

REQUIRED SERVICE MATERIAL

MATERIAL	RECOMMENDED SUZUKI PRODUCT	USE
Lithium grease	SUZUKI SUPER GREASE A (99000-25010)	<ul style="list-style-type: none"> ● Clutch master cylinder clevis pin. ● Release fork. ● Push rod tip of operating cylinder.
	SUZUKI SUPER GREASE I (99000-25210)	Input shaft spline front end.
Clutch fluid (Brake fluid)	DOT3 or SAE J1703	<ul style="list-style-type: none"> ● Clutch reservoir. ● Clutch master cylinder. ● Clutch operating cylinder.

SPECIAL TOOL

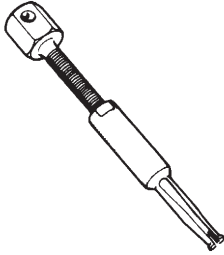
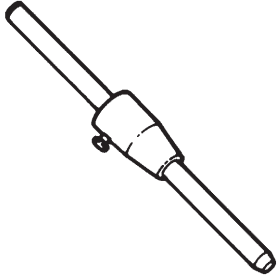
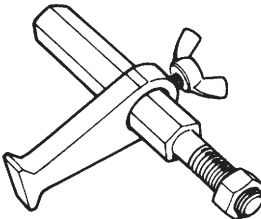
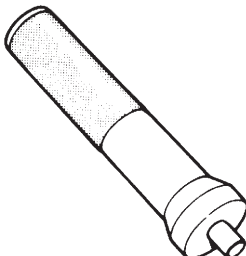
			
09923-73210 Bearing remover	09923-36320 Clutch center guide	09924-17811 Flywheel holder	09925-98210 Input shaft bearing installer

SECTION 7E

DIFFERENTIAL (FRONT)

NOTE:

For the descriptions (items) not found in this section, refer to the same section of the Service Manual mentioned in the FOREWORD of this manual.

CONTENTS

- GENERAL DESCRIPTION** 7E- 1
- 4WD CONTROL SYSTEM 7E- 2
- DIAGNOSIS** 7E- 5
- DIAGNOSIS TABLE 7E- 5
- DIFFERENTIAL ASSEMBLY 7E- 5
- 4WD CONTROL SYSTEM DIAGNOSTIC FLOW TABLE 7E- 6
- 4WD CONTROL CIRCUIT INSPECTION 7E- 8
- ON-VEHICLE SERVICE** 7E- 9
- INSPECTION 7E- 9
- 4WD CONTROL SYSTEM 7E- 9
- ACTUATOR 7E-10
- AIR PUMP ASSEMBLY 7E-11
- REMOVAL AND INSTALLATION 7E-12
- DIFFERENTIAL MOUNTINGS 7E-12
- DISMOUNTING 7E-14
- REMountING 7E-15
- TIGHTENING TORQUE SPECIFICATIONS** 7E-16
- SPECIAL TOOLS** 7E-16

GENERAL DESCRIPTION

The differential assembly using a hypoid bevel pinion and gear is installed to the front axle.

4WD control system controls drive force to be transmitted to front axles or not. The reduction ratio varies depending on transmission.

The differential assembly is decisive in that the drive power is concentrated there. Therefore, use of genuine parts and specified torque is compulsory. Further, because of sliding tooth meshing with high pressure between bevel pinion and gear, it is mandatory to lubricate them by hypoid gear oil.

4WD CONTROL SYSTEM

When the 4WD switch is turned ON by shifting the transfer shift lever, 4WD controller actuates (energizes) the air pump assembly. Then positive pressure is sent from the air pump assembly to the actuator installed to the differential case and causes the axle lock clutch and the free axle hub in the differential case to be engaged, resulting in the 4WD mode. Only when running in the 4WD mode, front axles are joined to differential case, and they become free when 2WD mode is used (or when transfer shift lever is shifted to N position), thereby reducing the power loss.

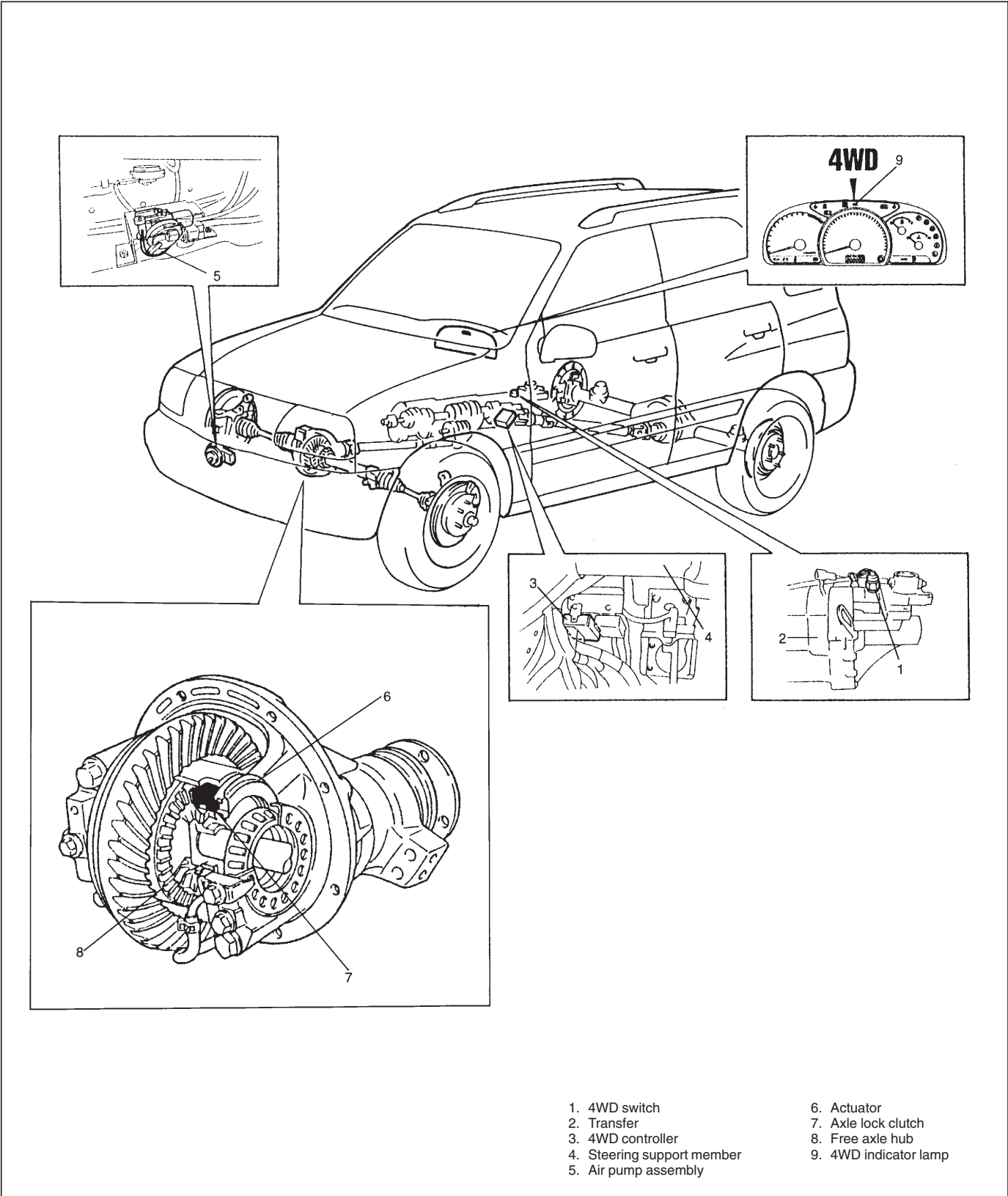

System Circuit and Operation

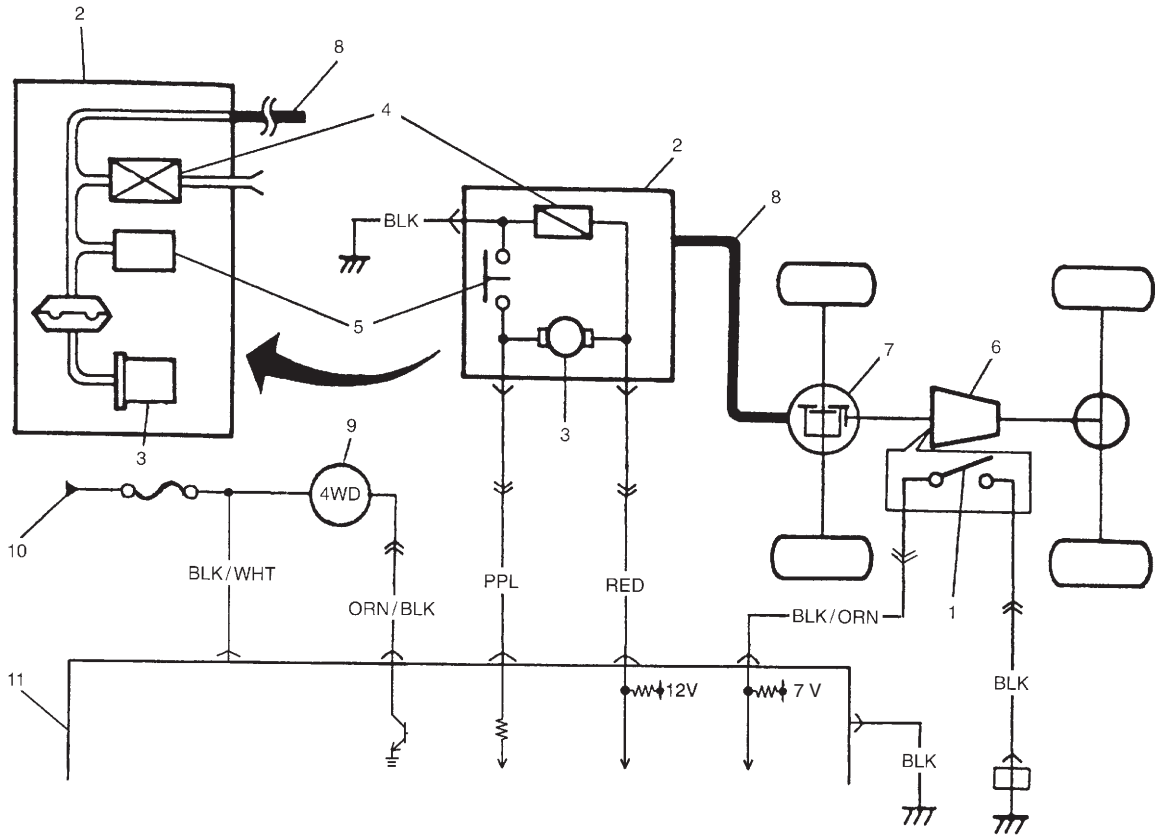

- 1. 4WD switch
- 2. Air pump assembly
- 3. Pump motor
- 4. Release valve
- 5. Pressure switch
- 6. Transfer
- 7. Front differential
- 8. Air hose and pipe
- 9. 4WD indicator lamp
- 10. To ignition switch
- 11. 4WD controller

Operation (refer to "Components and Functions")

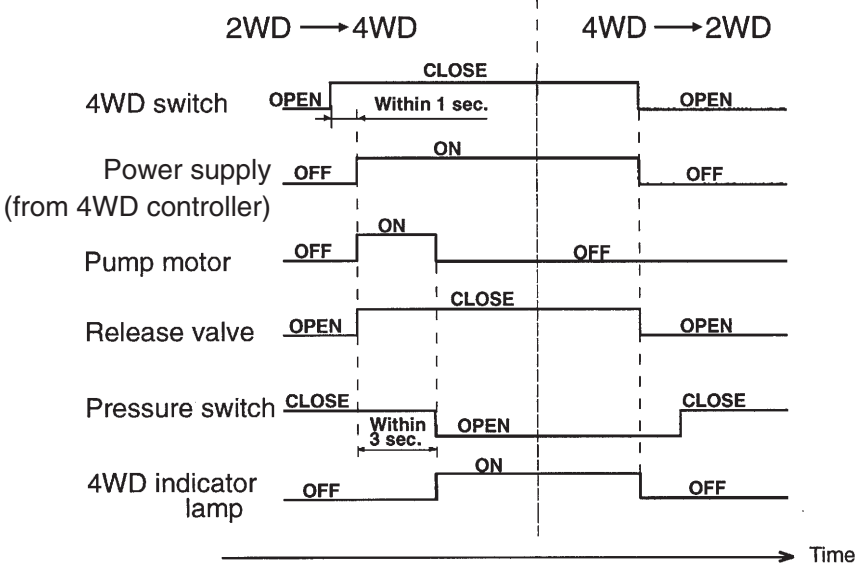

Components and Functions

Component	Function
4WD switch	When the transfer shift lever is shifted to 4L or 4H position, this switch turns ON and causes the 4WD control system to turn ON, unless it is shifted to N or 2H within 1 second.
4WD controller	When the 4WD switch turns ON [unless it turns OFF within 1 second], this component actuates the pump assembly. If the pressure in the air pump assembly fails to increase higher than the set level even after the pump motor has run more than 10 seconds, this component stops the motor to protect it.
Air pump assembly <ul style="list-style-type: none"> ● Pump motor ● Release valve ● Pressure switch 	The air pump assembly consists of a pump motor, release valve and a pressure switch. Pump motor: Produces positive pressure which actuates the actuator. Release valve: Closes when transfer shift lever is shifted to 4H or 4L so that the positive pressure is applied to the actuator, and opens when N or 2H to release the pressure to the atmosphere. Pressure switch: Turns ON and OFF depending on the pressure level in the pump assembly (whether higher or lower than the set pressure level). 4WD controller detects the pressure level through this switch.
Differential case assembly <ul style="list-style-type: none"> ● Free axle hub ● Axle lock clutch ● Actuator 	The free axle hub, axle lock clutch and actuator are installed in the differential left case. The positive pressure produced in the air pump assembly is applied to the actuator which then pushes the axle lock clutch to be engaged with the free axle hub. In this state, the drive force is transmitted to the front axle, resulting in the 4WD mode. When the actuator is free from the positive pressure [when it is under the atmospheric pressure], the axle lock clutch is pushed back by the return spring force and cannot be engaged with the free axle hub, resulting in the 2WD mode.
"4WD" indicator lamp	It lights up when 4WD control system is in the 4WD mode.

DIAGNOSIS

DIAGNOSIS TABLE DIFFERENTIAL ASSEMBLY

Condition	Possible Cause	Correction
Gear noise	<ul style="list-style-type: none"> ● Deteriorated or water mixed lubricant ● Inadequate or insufficient lubricant ● Maladjusted backlash between bevel pinion and gear ● Improper tooth contact in the mesh between bevel pinion and gear ● Loose bevel gear securing bolts ● Damaged side gear(s) or side pinion(s) 	Repair and replenish Repair and replenish Adjust Adjust or replace Replace or retighten Replace
Bearing noise	<ul style="list-style-type: none"> ● (Constant noise) Deteriorated or water mixed lubricant ● (Constant noise) Inadequate or insufficient lubricant ● (Noise while coasting) Damaged bearing(s) of bevel pinion ● (Noise while turning) Damaged diff. side bearing(s) or axle bearing(s) 	Repair and replenish Repair and replenish Replace Replace
Oil leakage	<ul style="list-style-type: none"> ● Worn or damaged oil seal ● Excessive oil ● Loose differential carrier bolts 	Replace Adjust oil level Replace or retighten
2WD/4WD switching error	<ul style="list-style-type: none"> ● Defective actuator ● Abnormality in 4WD control system 	Replace Inspect referring to "4WD CONTROL SYSTEM DIAGNOSTIC FLOW TABLE".

4WD CONTROL SYSTEM DIAGNOSTIC FLOW TABLE

Before performing the trouble diagnosis, check that the transfer and front differential are in good condition.

[NOTES ON SYSTEM CIRCUIT INSPECTION]

- Be sure to read “PRECAUTIONS FOR ELECTRICAL CIRCUIT SERVICE” in Section 0A before circuit inspection and observe what is written there.
- For system circuit, refer to the figure of “GENERAL DESCRIPTION” in this section.
- For terminal arrangement, refer to “4WD CONTROL CIRCUIT INSPECTION” in this section.

Step	Action	Yes	No
1	Inspect 4WD control system for air leakage and operation referring to “4WD CONTROL SYSTEM” of “ON-VEHICLE SERVICE” in this section. Is the result OK?	Go to Step 2.	Inspect for air leakage from air hoses. If OK, go to Step 3.
2	Inspect actuator for air leakage and operation referring to “ACTUATOR” of “ON-VEHICLE SERVICE” in this section. Is the result OK?	4WD control system and actuator are OK. Recheck transfer and front differential.	Inspect for air leakage from air hoses. If OK, inspect differential assembly referring to Section 7E in UNIT REPAIR MANUAL.
3	Inspect air pump assembly for air leakage and operation referring to “AIR PUMP ASSEMBLY” of “ON-VEHICLE SERVICE” in this section. Is the result OK?	Go to Step 4.	Replace air pump assembly.
4	Check ground circuit. 1) Disconnect connector from 4WD controller with ignition switch OFF. 2) Check for proper connection to 4WD controller at all terminal. 3) If OK, Check continuity between terminal E23-6 and body ground. Is there continuity between terminal E23-6 and body ground?	Go to Step 5.	“BLK” wire is open.
5	Check power circuit. 1) Disconnect connector from 4WD controller. 2) Turn ignition switch ON. 3) Check voltage between terminal E23-2 and ground. Is it 10 – 14 V?	Go to Step 6.	“BLK/WHT” circuit is open or short.
6	Check 4WD switch circuit. 1) Connect coupler to 4WD controller. 2) Turn ignition switch ON and check voltage between terminal E23-4 and ground. Transfer lever is in “N” or “2H”: 6 – 8 V Transfer lever is in “4L” or “4H”: 0 – 1 V	Go to step 7.	Check 4WD switch (refer to Section 7A2), “BLK/ORN” and “BLK” circuit of 4WD switch. If OK, substitute a known-good 4WD controller and recheck.

Step	Action	Yes	No
7	Check 4WD controller. 1) Turn ignition switch ON. 2) Check voltage between terminal E23-3 and ground. Transfer lever is in "N" or "2H": 0 – 1 V Transfer lever is in "4L" or "4H": 10 – 14 V (1 second after transfer lever is shifted to "4H" or "4L".)	Go to Step 8.	Substitute a known-good 4WD controller and recheck.
8	Check 4WD controller. 1) Check for proper connection to air pump assembly at all terminals. 2) Turn ignition switch ON. 3) Check voltage between terminal E23-7 and ground. Transfer lever is in "N" or "2H": 0 – 1 V Transfer lever is in "4L" or "4H": 10 – 14 V (4 seconds after transfer lever is shifted to "4H" or "4L".)	Go to Step 9.	Substitute a known-good 4WD controller and recheck.
9	Check 4WD indicator lamp circuit. 1) Turn ignition switch ON. 2) Check voltage between terminal E23-1 and ground. Transfer lever is in "N" or "2H": 10 – 14 V Transfer lever is in "4L" or "4H": 0 – 1 V (4 seconds after transfer lever is shifted to "4H" or "4L".)	Substitute a known-good 4WD controller and recheck.	Check "ORN/BLK" circuit (Including indicator lamp and combination meter). If OK, substitute a known-good 4WD controller and recheck.

4WD CONTROL CIRCUIT INSPECTION

VOLTAGE CHECK

Check for input or output voltage (voltage between each circuit and body ground) of 4WD controller with 4WD controller connector connected and ignition switch turned ON.

TER-MINAL	CIRCUIT	WIRE COLOR	NORMAL VOLTAGE	CONDITION
E23-1	4WD Indicator lamp	ORN/ BLK	10 – 14 V	Transfer shift lever: 2H or N
			0 – 1 V	4 seconds after transfer shift lever shifted to 4H or 4L
E23-2	Ignition switch	BLK/ WHT	10 – 14 V	Ignition switch: ON
E23-3	Air pump assembly (Pump motor and release valve)	RED	0 – 1 V	Transfer shift lever: 2H or N
			10 – 14 V	1 seconds after transfer shift lever shifted to 4H or 4L
E23-4	4WD switch	BLK/ ORN	6 – 8 V	Transfer shift lever: 2H or N
			0 – 1 V	Transfer shift lever: 4H or 4L
E23-6	Ground	BLK	0 – 1 V	–
E23-7	Air pump assembly (pressure switch)	PPL	0 – 1 V	Transfer shift lever: 2H or N
			10 – 14 V	4 seconds after transfer shift lever shifted to 4H or 4L

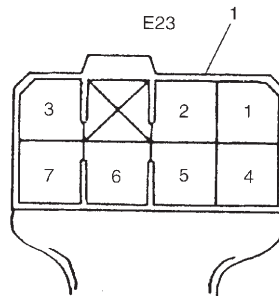

1. 4WD controller connector terminal arrangement

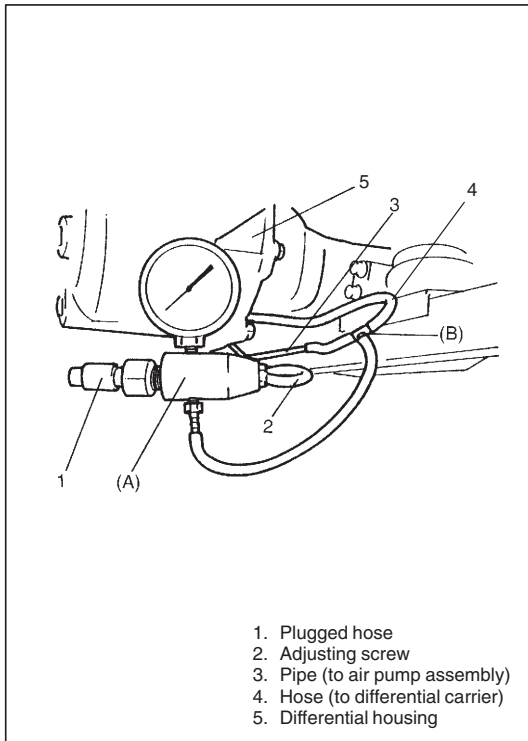

ON-VEHICLE SERVICE

INSPECTION

4WD CONTROL SYSTEM

- 1) Install special tool to air hose connecting between air pump assembly and differential (actuator) as shown in figure. Tighten adjusting screw of special tool as far as it stops. Close air check side opening by using fuel hose as blind plug.

Special Tool

(A): 09918-18111

(B): 09367-04002

NOTE:

Use care not to bend any part of hose.

- 2) Turn ON ignition switch and shift transfer lever from 2H to 4H range.
- 3) Check that motor starts running (a sound can be heard) within 1 second and it stops when gauge of special tool indicates specified pressure value.
Check also for air leakage.

Pressure specification:

30.0 – 45.0 kPa (0.30 – 0.45 kg/cm², 4.25 – 6.40 psi)

- 4) Check that pressure value indicated on gauge of special tool drops as soon as transfer lever is shifted to 2H position.
- 5) Start motor by shifting transfer lever to 4H position again. Loosen adjusting screw to lower pressure value on gauge. Motor should start to run again and stop in about 4 seconds.
- 6) With the adjusting screw of special tool loosened, shift transfer shift lever to N or 2H position and then 4L or 4H position. Pump motor should stop about 10 seconds after motor starts to run.

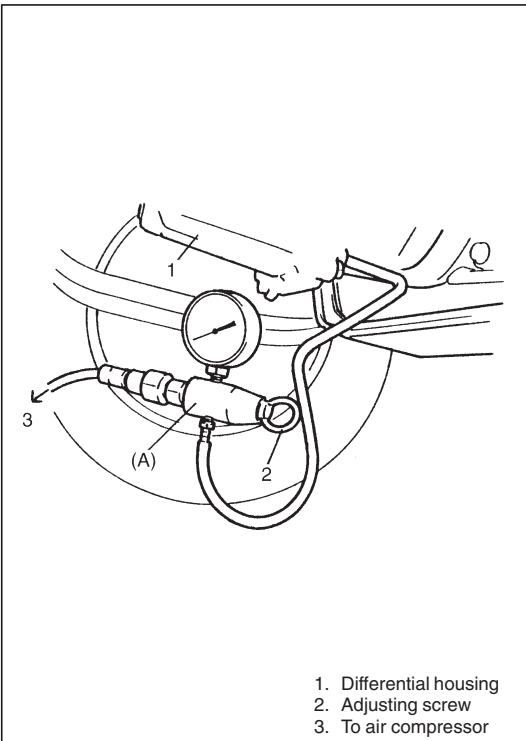

ACTUATOR

- 1) Disconnect air hose from pump assembly and install special tool to air hose as shown in figure. Loosen adjusting screw of special tool.

Special Tool

(A): 09918-18111

- 2) Connect compressor air hose to special tool. Blow air and turn adjusting screw to obtain specified pressure.

Specified pressure: 30.0 kPa (0.3 kg/cm², 4.25 psi)

CAUTION:

Do not apply a pressure exceeding 200 kPa (2.0 kg/cm², 28.4 psi) which may cause damage to diaphragm.

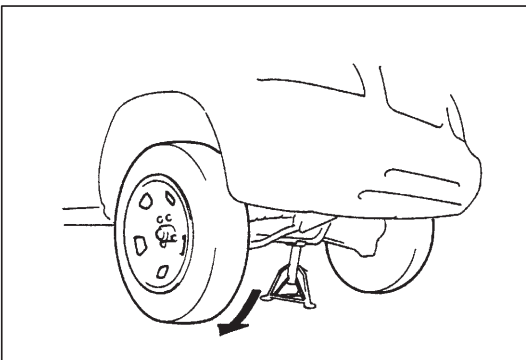

- 3) With the vehicle lifted so that both of the front wheels are off the ground, turn one of the front wheels by hand and check the other wheel, which should act as described below.

- When the pressure from compressor is applied to actuator:
The other front wheel should turn in the direction opposite to the wheel being turned by hand.
- When the pressure from compressor is not applied to actuator:
The other front wheel should remain stationary while the wheel pushed by hand is turning.

If the result is not satisfactory, inspect differential assembly. Refer to "INSPECTION" of SECTION 7E in UNIT REPAIR MANUAL.

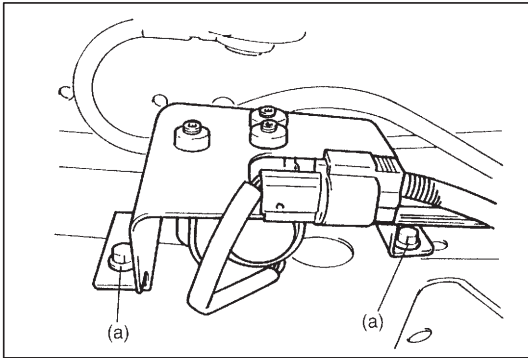

AIR PUMP ASSEMBLY

Removal/Installation

- 1) Disconnect air hoses and coupler from air pump assembly.
- 2) Remove pump assembly by removing bolts.
- 3) Reverse removal procedure for installation.

Tightening Torque

(a): 13 N·m (1.3 kg-m, 9.5 lb-ft)

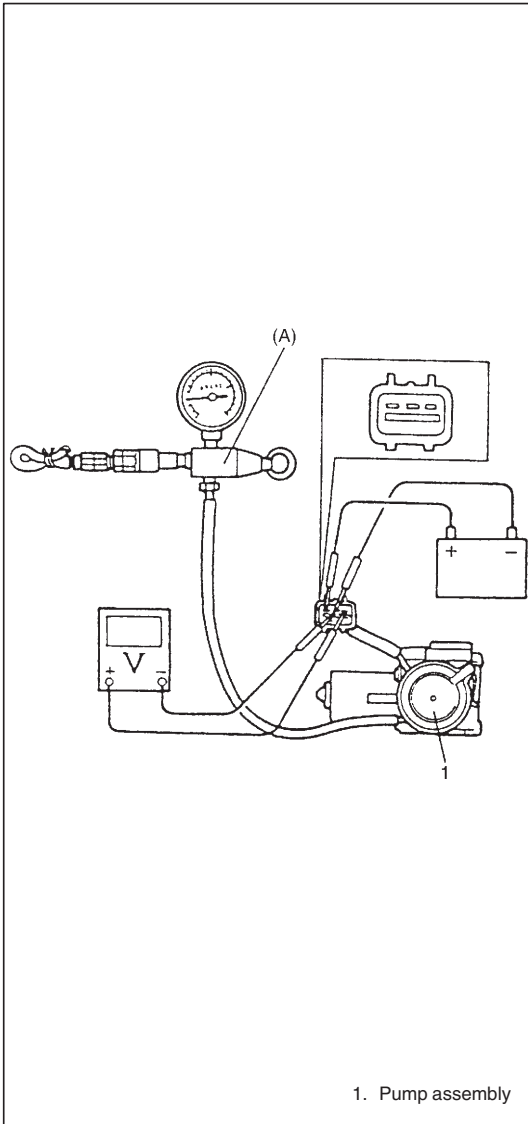

Inspection

- 1) Install special tool, voltmeter and battery to pump assembly as shown in figure.
- 2) Tighten adjusting screw of special tool as far as it stops and close its air check side opening by using fuel hose as blind plug.

Special Tool

(A): 09918-18111

- 3) Check that motor starts to run (a sound can be heard) when battery is connected and it stops when specified pressure is obtained.

Check also for air leakage.

Specified pressure: 30.0 – 45.0 kPa

(0.30 – 0.45 kg/cm², 4.25 – 6.40 psi)

- 4) Check that value indicated on voltmeter is within specification shown below.

When motor is running: 0 – 1 V

When motor has stopped running: 10 – 14 V

CAUTION:

Do not run motor more than 10 seconds continuously to prevent motor breakage.

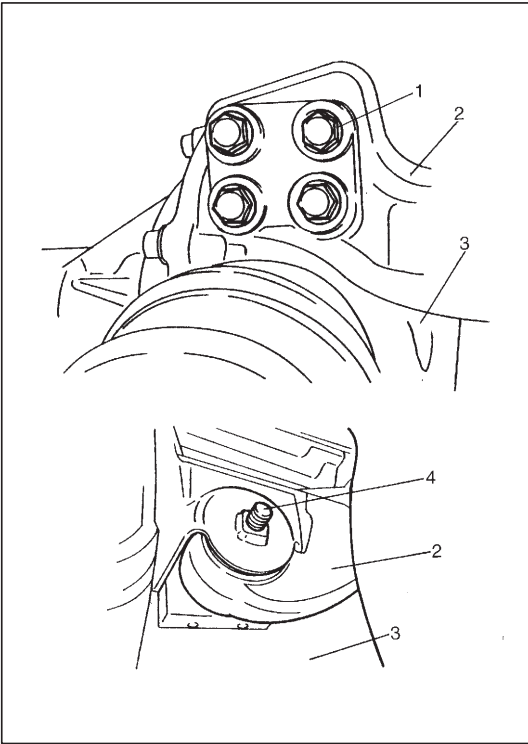

REMOVAL AND INSTALLATION

DIFFERENTIAL MOUNTINGS

- 1) Lift up vehicle and turn steering wheel all way to the right.
- 2) Separate front mounting bracket R (2) from differential housing (3) by removing bolts (1) from its lower part.
- 3) Remove mounting bracket R (2) by removing mounting front bolt (4) from its upper part.

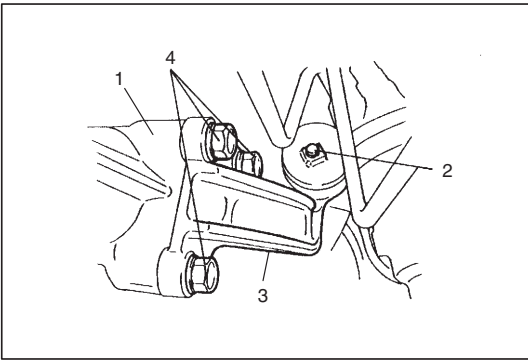

- 4) Remove mounting bracket L (3) from differential housing (1) by removing upper and lower fastening bolts (2, 4).

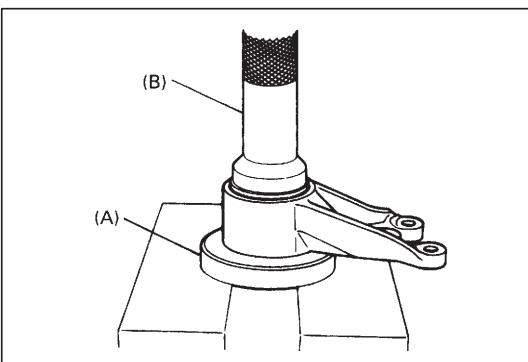

- 5) Check conditions of each bush. If it is damaged or deteriorated, drive it out with special tools and press for replacement.

Special Tool

(A): 09951-26010

(B): 09951-16080

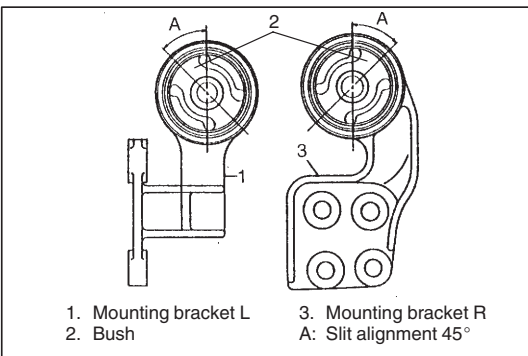

- 6) Position slit in each bush as shown when press-fitting it.

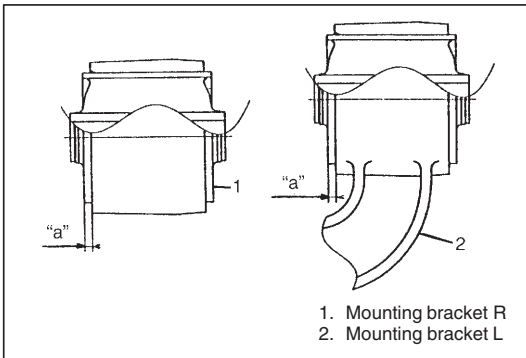

7) Position each bush to bracket as shown.

Length "a": 3.0 mm (0.12 in.)

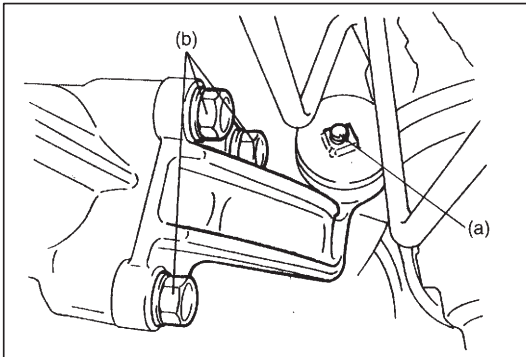

8) Use following torque for reinstallation.

Tightening Torque

Front mounting bolt (a):

85 N·m (8.5 kg-m, 61.5 lb-ft)

Front mounting bracket bolt (b):

50 N·m (5.0 kg-m, 36.5 lb-ft)

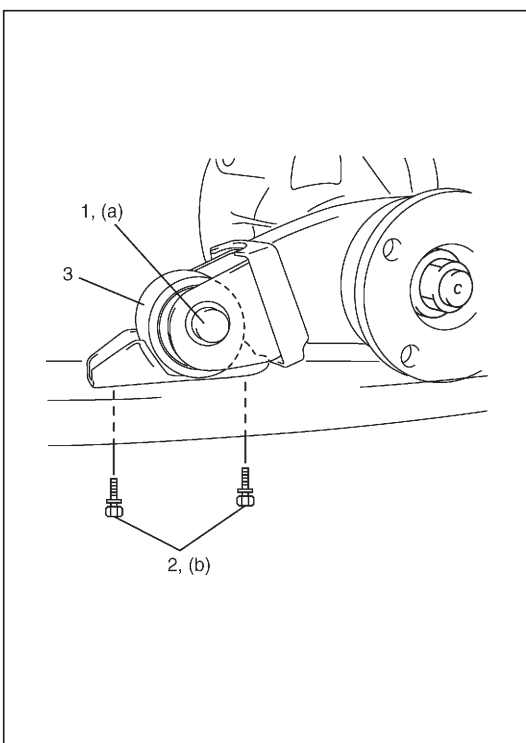

REAR MOUNTING

(For front differential carrier)

- 1) Lift up vehicle and remove rear mounting bracket (3) by removing rear mounting bolt (1) and rear mounting bracket bolts (2).
- 2) Check mounting rubber for damage or deterioration and replace as necessary.
- 3) Tighten rear mounting bolts (1) and rear mounting bracket bolts (2) to specified torque for reinstallation.

Tightening torque

Rear mounting bolt (a):

85 N·m (8.5 kg-m, 61.5 lb-ft)

Rear mounting bracket bolts (b):

60 N·m (6.0 kg-m, 43.5 lb-ft)

DISMOUNTING

- 1) Lift up vehicle and drain oil.
- 2) Disconnect air hose and breather hose from differential housing.

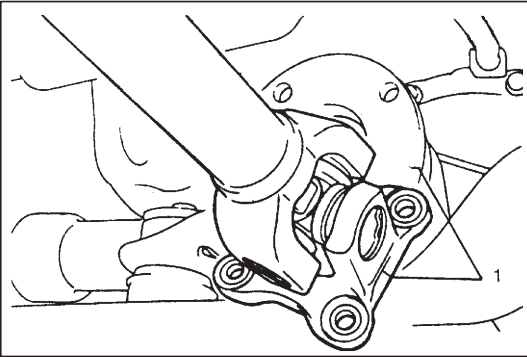

- 3) Before removing propeller shaft, give match marks (1) on joint flange and propeller shaft as shown.
- 4) Remove propeller shaft flange by removing its 4 bolts and suspend it with cord or the like.

NOTE:

If pull out propeller shaft, transfer oil must be drained before pulling out.

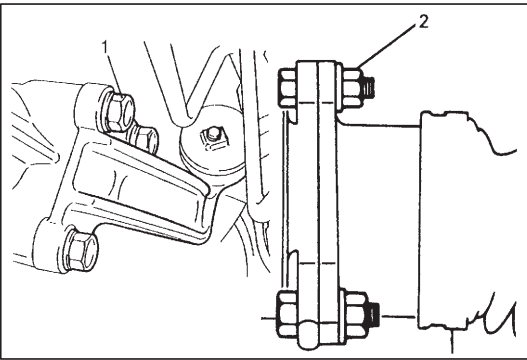

- 5) Remove bolts (1) for left mounting bracket and bolts and nuts (2) for drive shaft flange to set left side of differential free.

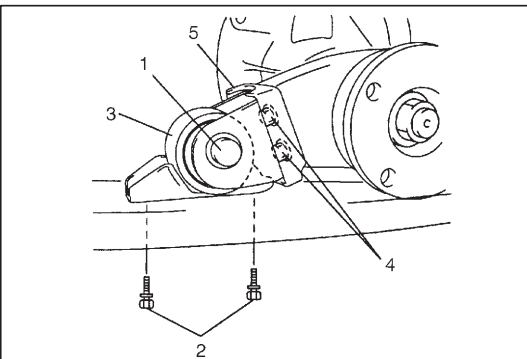

- 6) Remove bolts (1, 2) and rear mounting bracket (3).
- 7) Remove bolts (4) and rear mounting bracket No.2 (5).

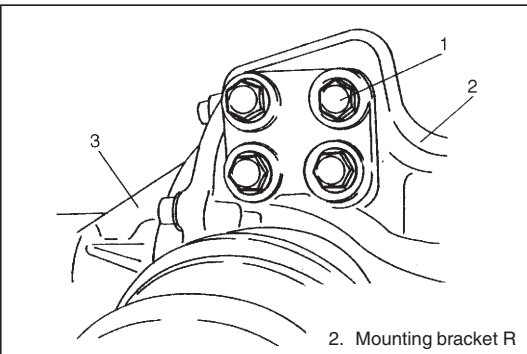

- 8) With differential housing assembly held with transmission jack, remove mounting bracket bolts (1) on right end of housing (3).

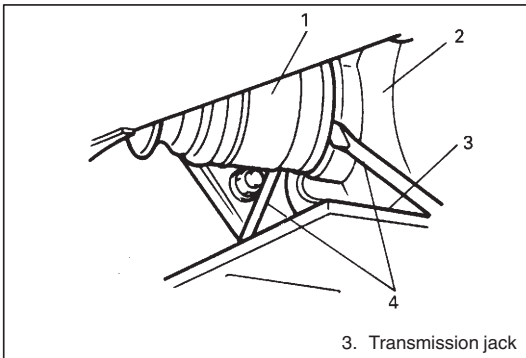

- 9) Using 2 large screwdrivers (4) as levers, pull out right side drive shaft joint (1) from differential (2) and dismount housing assembly from vehicle.

CAUTION:

During above work, use care not to cause damage to drive shaft boot.

REMountING

For remounting, reverse dismounting procedure and use following tightening torque.

Tightening torque

Propeller shaft flange bolts (a):

50 N·m (5.0 kg-m, 36.5 lb-ft)

Front drive shaft flange bolts (b):

50 N·m (5.0 kg-m, 36.5 lb-ft)

Front mounting bracket bolts (c):

50 N·m (5.0 kg-m, 36.5 lb-ft)

Rear mounting bracket bolts (d):

60 N·m (6.0 kg-m, 43.5 lb-ft)

Rear mounting bolt (e):

85 N·m (8.5 kg-m, 61.5 lb-ft)

Rear mounting bracket No.2 bolts (f):

85 N·m (8.5 kg-m, 61.5 lb-ft)

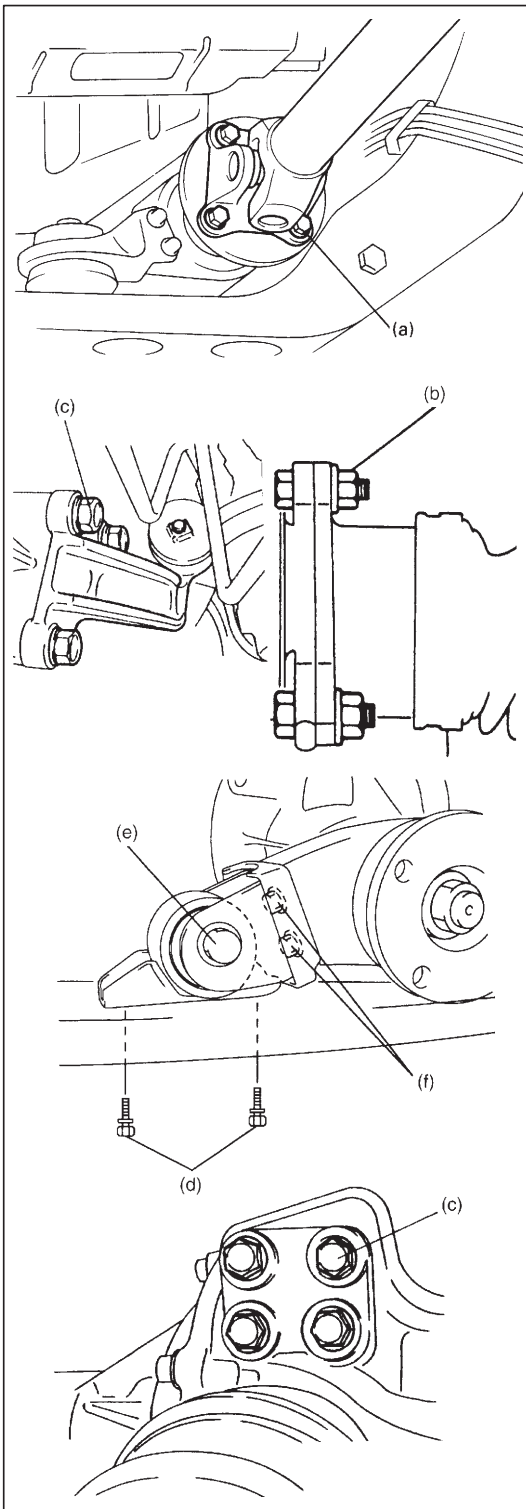

After tightening all fasteners properly, fill hypoid gear oil as specified and check tightening of plugs with specification.

TIGHTENING TORQUE SPECIFICATION

Fastening part	Tightening torque		
	N·m	kg·m	lb·ft
Differential oil level/filler plug	23	2.3	17.0
Differential oil drain plug	23	2.3	17.0
Front mounting bolts	85	8.5	61.5
Front mounting bracket bolts	50	5.0	36.5
Front drive shaft flange bolts	50	5.0	36.5
Propeller shaft flange bolts	50	5.0	36.5
Pump assembly bolts	13	1.3	9.5
Rear mounting bolt	85	8.5	61.5
Rear mounting bracket bolts	60	6.0	43.5
Rear mounting bracket No.2 bolts	85	8.5	61.5

SPECIAL TOOL

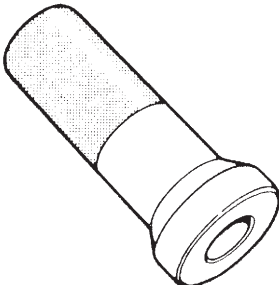
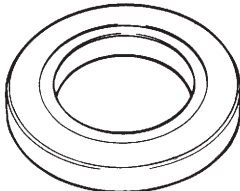
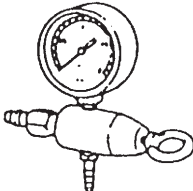
		
09951-16080 Bearing installer	09951-26010 Bush remover plate	09918-18111 Air pressure regulator 09367-04002 3-way joint

SECTION 7F

DIFFERENTIAL (REAR)

CONTENTS

GENERAL DESCRIPTION	7F- 2	COMPONENT INSPECTION	7F- 9
DIAGNOSIS	7F- 2	SUB-ASSEMBLY ADJUSTMENT AND REASSEMBLY	7F- 9
DIAGNOSIS TABLE	7F- 2	DIFFERENTIAL CARRIER	7F- 9
ON-VEHICLE SERVICE	7F- 3	DIFFERENTIAL CASE	7F-10
PRECAUTION FOR MAINTENANCE SERVICE	7F- 4	DIFFERENTIAL SIDE BEARING	7F-12
DIFFERENTIAL GEAR OIL CHANGE ...	7F- 4	DRIVE BEVEL PINION	7F-13
REAR DIFFERENTIAL ASSEMBLY	7F- 5	ASSEMBLING UNIT	7F-18
DISMOUNTING	7F- 5	TIGHTENING TORQUE SPECIFICATION .	7F-21
REMOUNTING	7F- 5	REQUIRED SERVICE MATERIAL	7F-21
UNIT REPAIR	7F- 6	SPECIAL TOOL	7F-22
DISASSEMBLING UNIT	7F- 6		

GENERAL DESCRIPTION

The differential assembly using a hypoid bevel pinion and gear is installed to the rear axle. It is set in the conventional type axle housing.

The differential assembly is decisive in that the drive power is concentrated there. Therefore, use of genuine parts and specified torque is compulsory. Further, because of sliding tooth meshing with high pressure between bevel pinion and gear, it is mandatory to lubricate them by hypoid gear oil.

DIAGNOSIS

DIAGNOSIS TABLE

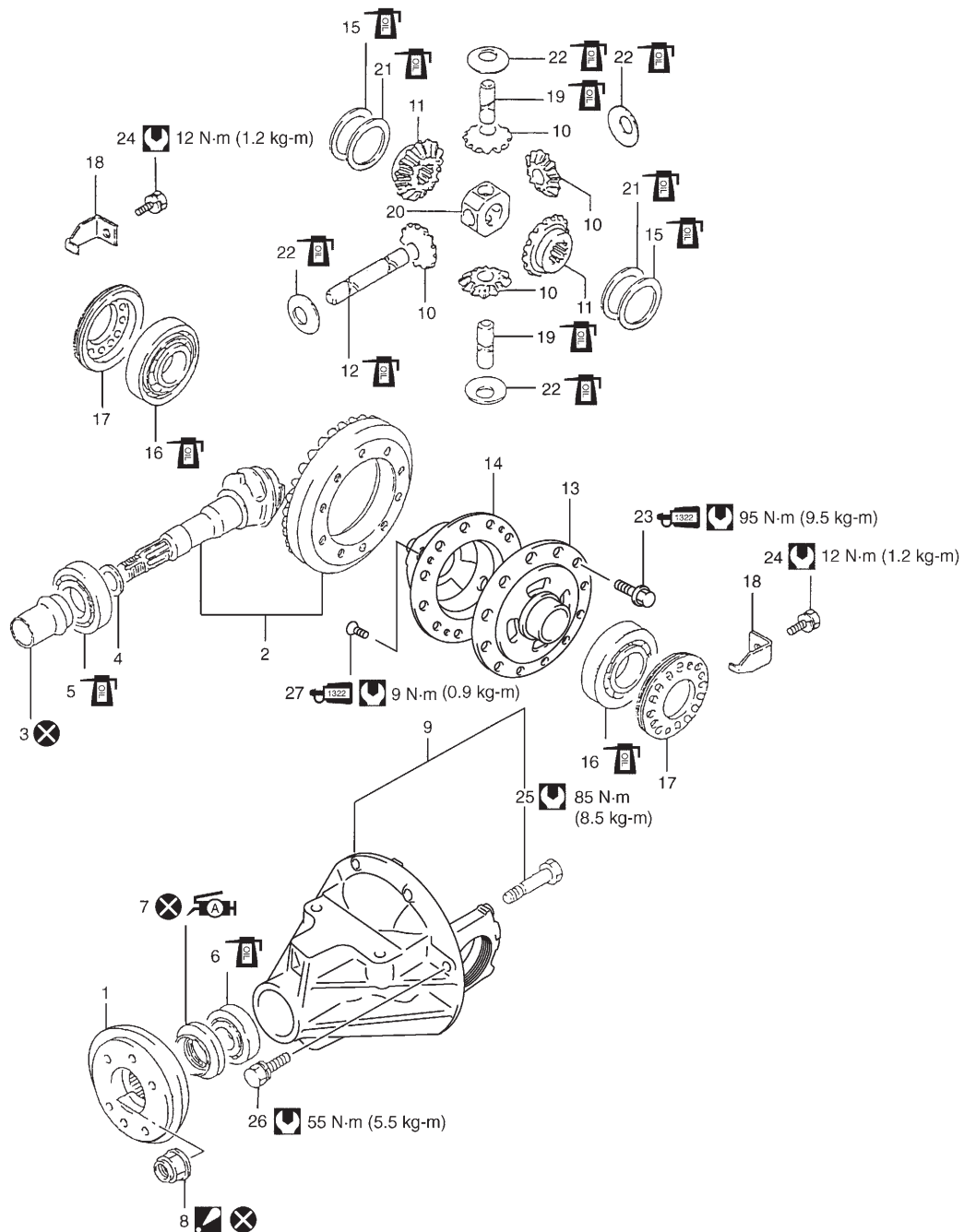

Condition	Possible Cause	Correction
Gear noise	Deteriorated or water mixed lubricant	Repair and replenish.
	Inadequate or insufficient lubricant	Repair and replenish.
	Maladjusted backlash between drive bevel pinion and gear	Adjust as prescribed.
	Improper tooth contact in the mesh between drive bevel pinion and gear	Adjust or replace.
	Loose drive bevel gear securing bolts	Replace or retighten.
	Damaged differential gear(s) or differential pinion(s)	Replace.
Bearing noise	(Constant noise) Deteriorated or water mixed lubricant	Repair and replenish.
	(Constant noise) Inadequate or insufficient lubricant	Repair and replenish.
	(Noise while coasting) Damaged bearing(s) of drive bevel pinion	Replace.
	(Noise while turning) Damaged differential side bearing(s) or axle bearing(s)	Replace.
Oil leakage	Clogged breather plug	Clean.
	Worn or damaged oil seal	Replace.
	Excessive oil	Adjust oil level.

ON-VEHICLE SERVICE



1. Universal joint flange
2. Hypoid gear set
3. Bevel pinion spacer
4. Shim
5. Rear bearing
6. Front bearing
7. Oil seal:
Apply grease 99000-25010 to oil seal lip.
8. Flange nut:
After tightening nut so as rotation torque of bevel pinion shaft to be in specified value, caulk nut securely.
9. Differential carrier assembly
10. Differential pinion
11. Differential gear
12. Pinion shaft No.1
13. Differential left case
14. Differential right case

15. Thrust washer
16. Differential side bearing
17. Bearing adjuster
18. Lock plate
19. Pinion shaft No.2
20. Pinion joint
21. Spring washer
22. Washer
23. Bevel gear bolt:
Apply thread lock cement 99000-32110 to thread part of bolt.
24. Bolt
25. Bolt
26. Bolt
27. Differential case screw:
Apply thread lock cement 99000-32110 to thread part of bolt.

- ⊗ : Do not reuse.
 : Tightening torque
 : Apply differential oil.

PRECAUTION FOR MAINTENANCE SERVICE

- When having driven through water, check immediately if water has entered (if so, oil is cloudy). Water mixed oil must be changed at once.
- Whenever vehicle is hoisted for any other service work than oil change, also be sure to check for oil leakage and status of breather hoses.

DIFFERENTIAL GEAR OIL CHANGE

NOTE:

- **Hypoid gear oil must be used for differential.**
- **It is highly recommended to use SAE 80W-90 viscosity.**

- 1) Before oil change or inspection, be sure to stop engine and lift up vehicle horizontally.
- 2) Check oil level and existence of leakage. If leakage is found, correct its cause.

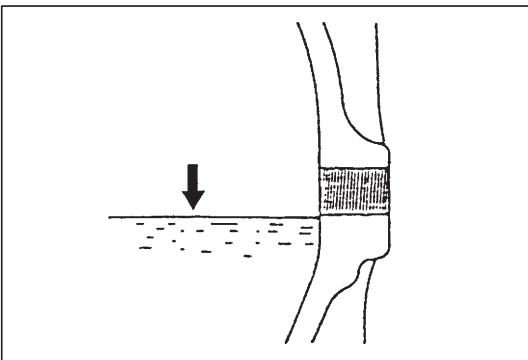

- 3) Drain old oil and pour proper amount of gear oil as specified (roughly up to level hole).

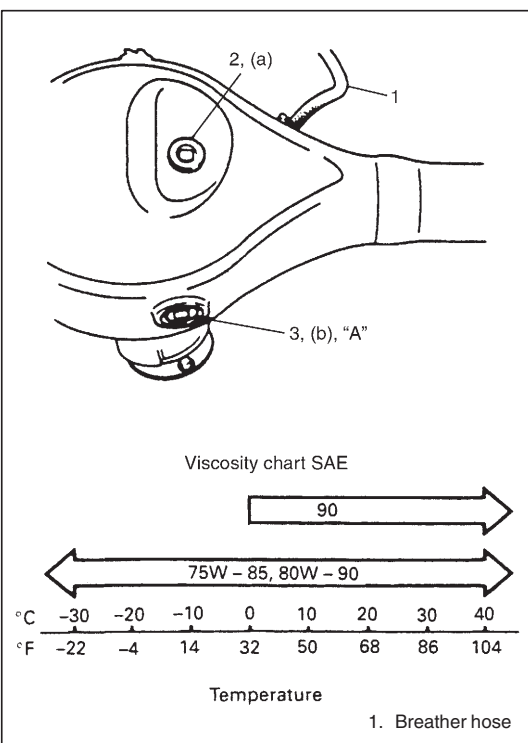

- 4) Torque drain plug (3) and level/filler plugs (2) to specification.

“A”: Sealant 99000-31110

Tightening torque

Differential oil level/filler plug (a):

50 N·m (5.0 kg-m, 36.5 lb-ft)

Differential oil drain plug (b):

28 N·m (2.8 kg-m, 20.5 lb-ft)

Hypoid gear oil:

API GL-5, SAE 75W-85, 80W-90 or 90

Oil capacity:

2.5 liters (5.3/4.4 US/Imp. pt.)

REAR DIFFERENTIAL ASSEMBLY

DISMOUNTING

- 1) Lift up vehicle and drain oil from rear differential housing.
- 2) Remove rear brake drums and pull out right and left rear axle shafts. (Refer to "REAR AXLE SHAFT REMOVAL" of Section 3E.)

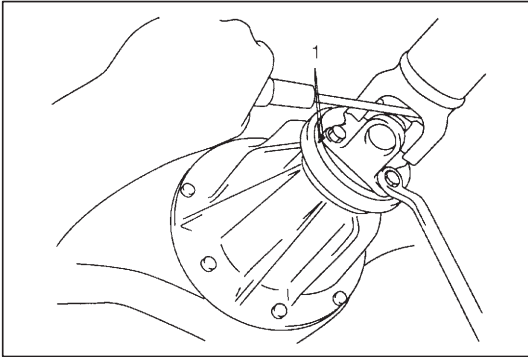

- 3) Before removing propeller shaft, give match marks (1) on joint flange and propeller shaft as shown.
- 4) Remove propeller shaft by removing its flange bolts.

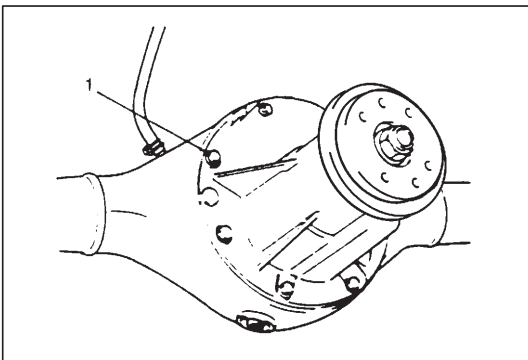

- 5) Remove differential assembly by removing its 8 fastening bolts (1).

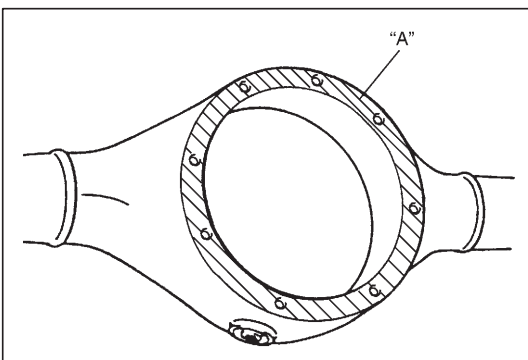

REMountING

- 1) Clean mating surfaces of rear axle and differential assembly and apply sealant to axle side evenly.

"A": Sealant 99000-31110

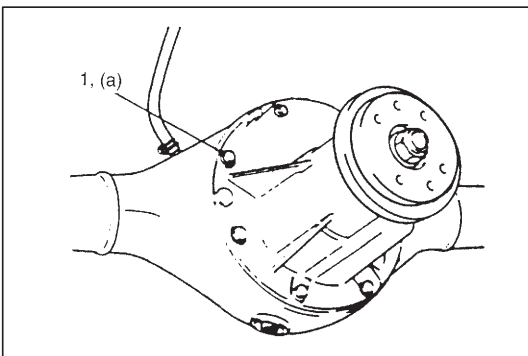

- 2) Install differential assembly to axle and fix it with bolts (1) tightened to specified torque.

Tightening torque

Differential carrier bolts (a):

55 N·m (5.5 kg-m, 40.0 lb-ft)

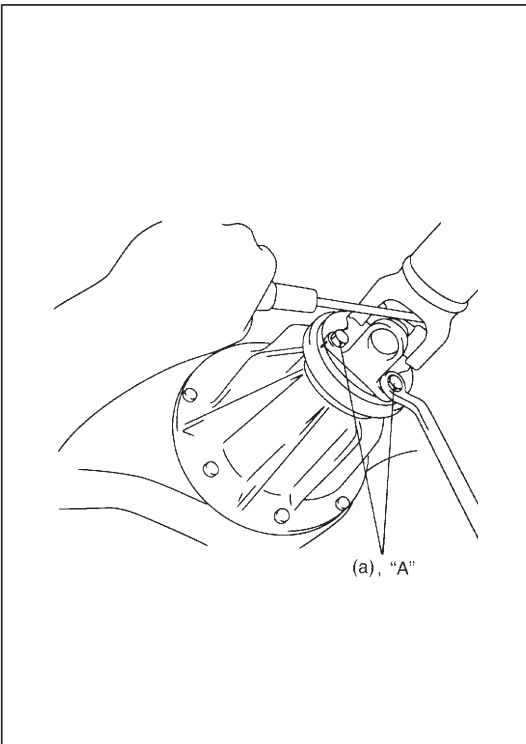

- 3) Install propeller shaft to joint flange aligning match marks and torque flange bolts to specification. Apply thread lock cement to thread part of bolt if reused.

"A": Cement 99000-32110

Tightening torque

**Propeller shaft flange bolts (a):
60 N·m (6.0 kg-m, 43.5 lb-ft)**

- 4) Install right and left rear axle shafts and drums.
(Refer to "REAR AXLE INSTALLATION" of Section 3E and rear brake drum installation of Section 5.)
- 5) Install wheels.
- 6) Fill hypoid gear oil as specified and tighten plug to specification.
- 7) Lower lift.

UNIT REPAIR

DISASSEMBLING UNIT

- 1) Hold differential assembly securely and put identification marks on differential side bearing caps (6).
- 2) Take off differential side bearing lock plates (4) and differential side bearing caps (6) by removing their bolts and then take out bearing adjusters (5), side bearing outer races and drive bevel gear with differential case.

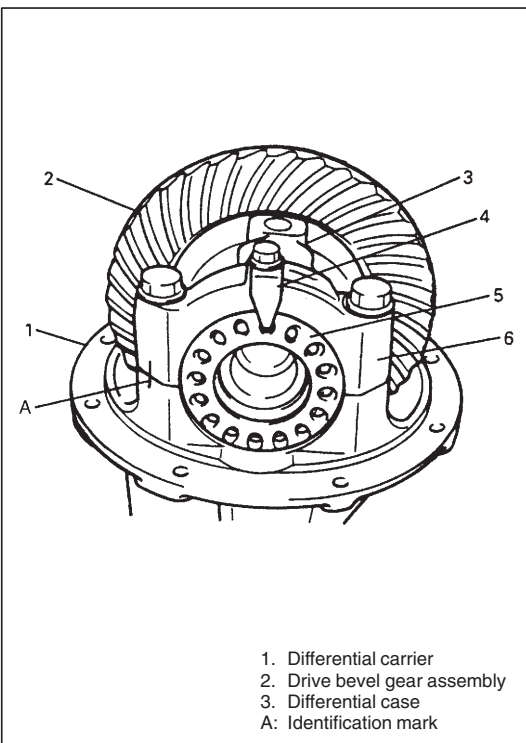

- 3) Remove drive bevel gear (hypoid gear), differential gears, differential pinions and pinion shafts.
 - a) With aluminum plates (2) placed on vise first, grip differential case with it and remove drive bevel gear (hypoid gear) (3) by removing its bolts (1).

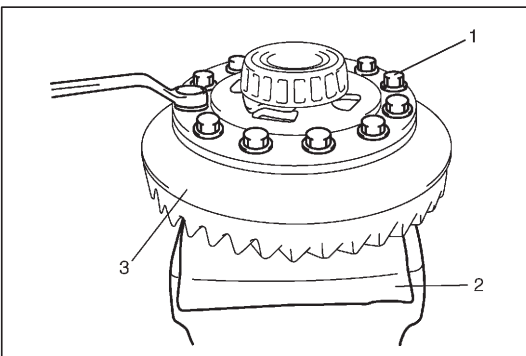

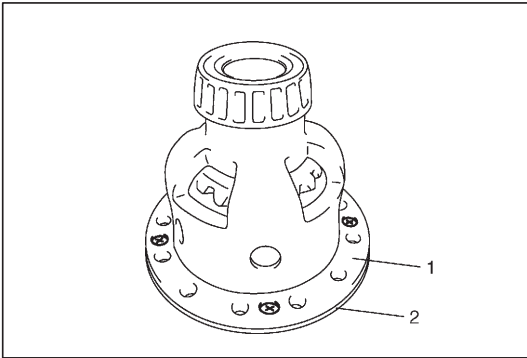

- b) Remove differential left case (2) from differential right case (1).

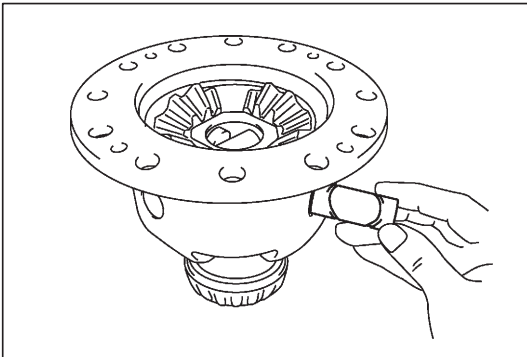

- c) Remove pinion shafts, differential gears, washers, differential pinions, spring washers, thrust washers.

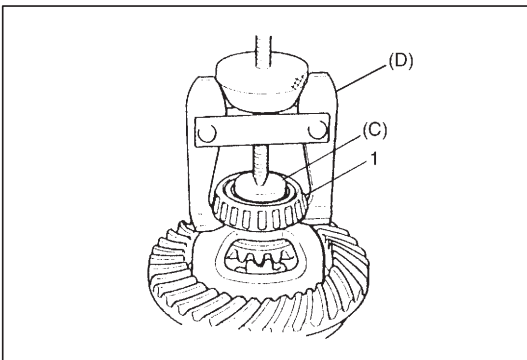

- 4) Using special tools, pull out differential side bearings (1).

Special tool

(C): 09913-85230

(D): 09913-61510

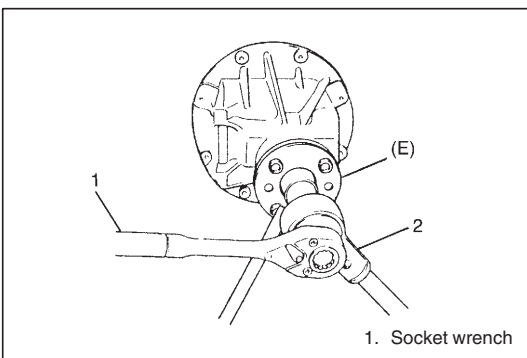

- 5) Remove drive bevel pinion (hypoid gear) assembly.

- a) Hold universal joint flange with special tool and then remove flange nut by using power wrench (4 – 10 magnification) (2).

Special tool

(E): 09922-66021

1. Socket wrench

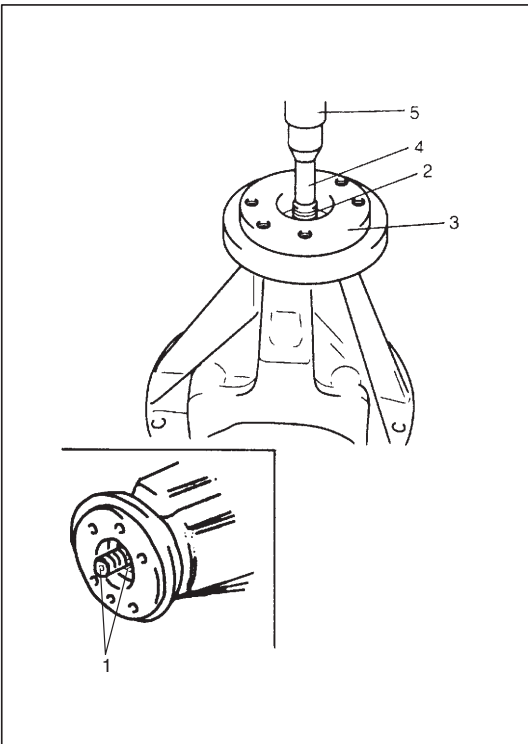

- b) Make mating marks (1) on drive bevel pinion and companion flange.

CAUTION:
Don't make mating mark on the coupling surface of the flange.

- c) Press drive bevel pinion (2) by using rod (4) (approx. 22 mm (0.866 in.) in diameter) and press (5) then remove drive bevel pinion (2) and companion flange (3).

CAUTION:
Do not drop drive bevel pinion by holding its gear part by hand from beneath.

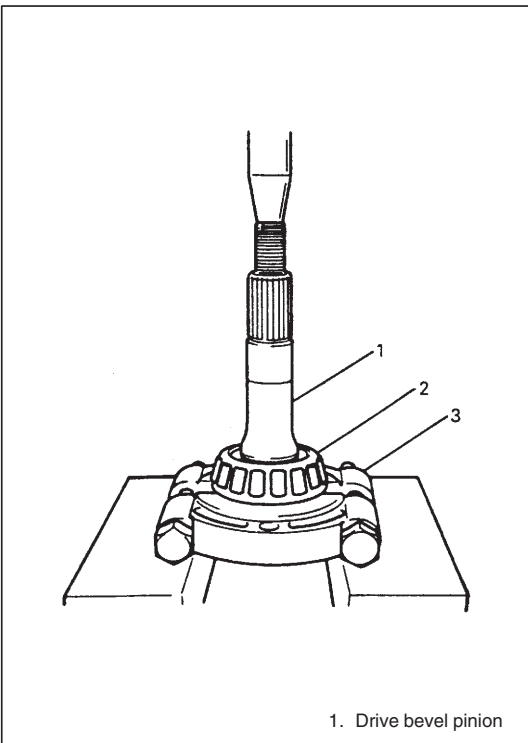

- d) Remove drive bevel pinion rear bearing (2) by using bearing puller (3) and press.

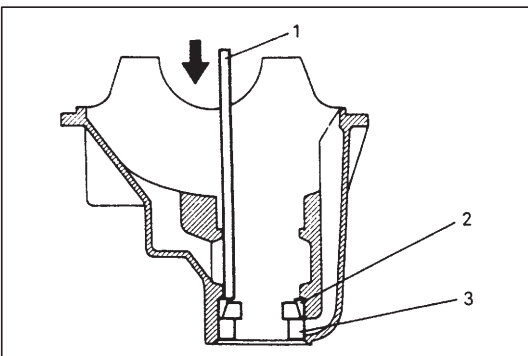

- 6) Using a hammer and brass bar (1), drive out front bearing outer race with bearing (2) and oil seal (3).

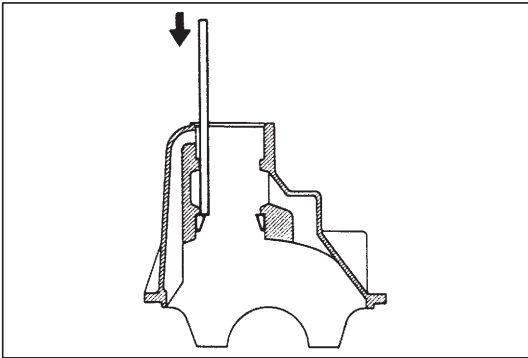

- 7) Drive out rear bearing outer race in the same way as in the Step 6).

COMPONENT INSPECTION

- Check companion flange for wear or damage.
- Check bearings for wear or discoloration.
- Check differential carrier for cracks.
- Check drive bevel pinion and drive bevel gear for wear or cracks.
- Check differential gears, pinions and pinion shafts for wear or damage.
- Check differential gear spline for wear or damage.

SUB-ASSEMBLY ADJUSTMENT AND REASSEMBLY

Judging from faulty conditions noted before disassembly and what is found through visual check of bearing and gear tooth etc. after disassembly, prepare replacing parts and proceed to reassembly according to procedures as described below.

CAUTION:

- Drive bevel gear and pinion must be replaced as a set when either replacement becomes necessary.
- When replacing taper roller bearing, replace as inner race & outer race assembly.

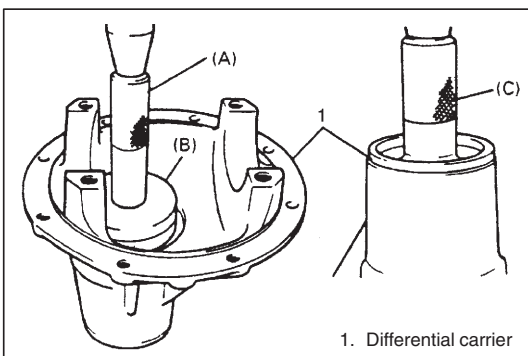

DIFFERENTIAL CARRIER

For press-fitting drive bevel pinion bearing outer races, use special tools as shown in the figure.

Special tool

- (A): 09924-74510
 (B): 09926-68310
 (C): 09913-75510

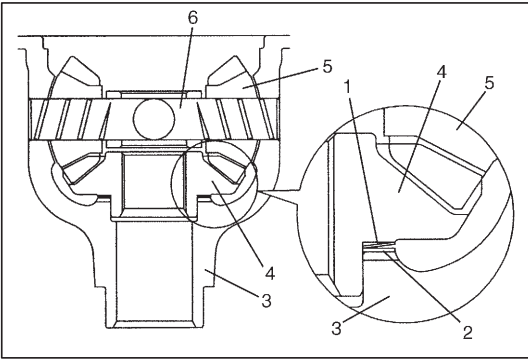

DIFFERENTIAL CASE

1) After applying differential oil to differential gear (4), pinions (5), pinion shafts (6), thrust washer (2) and spring washer (1), install them in differential right case (3).

For correct installing direction of thrust washer (2) and spring washer (1), refer to the figure.

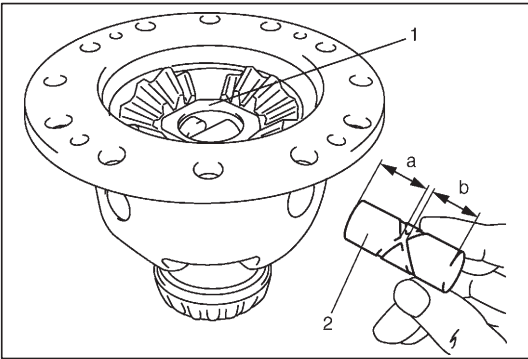

2) When installing pinion shaft No.2 (2) (shorter) into differential case and pinion, insert its "a" side into pinion joint (1).

NOTE:

"a" is longer than "b". ("a" > "b")

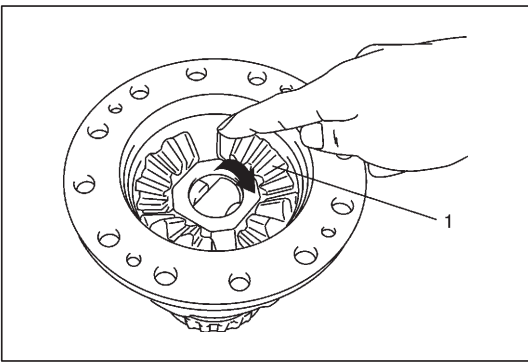

3) Check differential pinion gear (1) for smooth rotation.

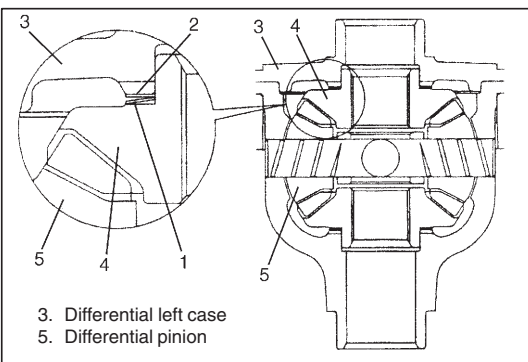

4) In the same manner as described in Step 1), install thrust washer (2), spring washer (1) and differential gear (4).

3. Differential left case
5. Differential pinion

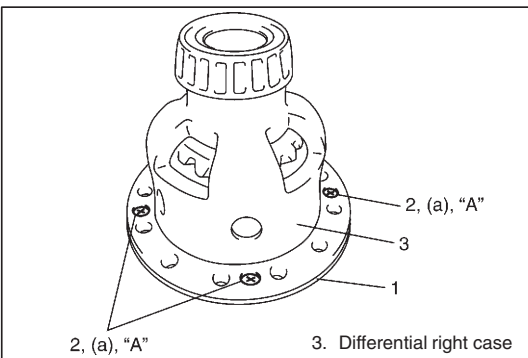

5) Install differential left case (1) and then tighten screws (2) to specified torque.

"A": Cement 99000-32110

Tightening torque

Differential case screw (a):

9 N·m (0.9 kg-m, 6.5 lb-ft)

2, (a), "A" 3. Differential right case

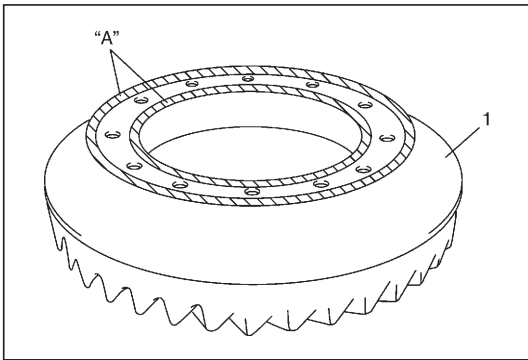

- 6) Clean and degrease mating surface of drive bevel gear (hypoid gear) (1).
- 7) Apply thread lock cement to hatched part of drive bevel gear (1) as shown in the figure.

“A”: Cement 99000-32110

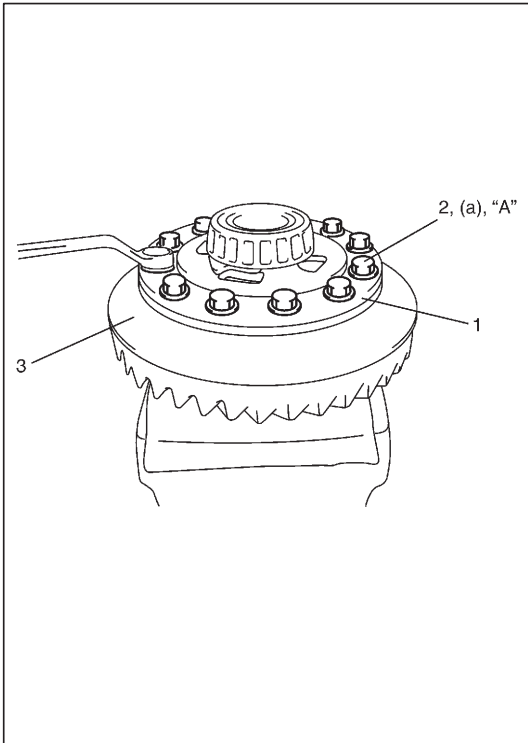

- 8) Put drive bevel gear (3) on differential case (1) and fasten them with bolts (2) by tightening them to specified torque. Use thread lock cement for bolts (2).

CAUTION:

Use of any other bolts than that specified is prohibited.

“A”: Cement 99000-32110

Tightening torque

Bevel gear bolts (a): 95 N·m (9.5 kg-m, 68.5 lb-ft)

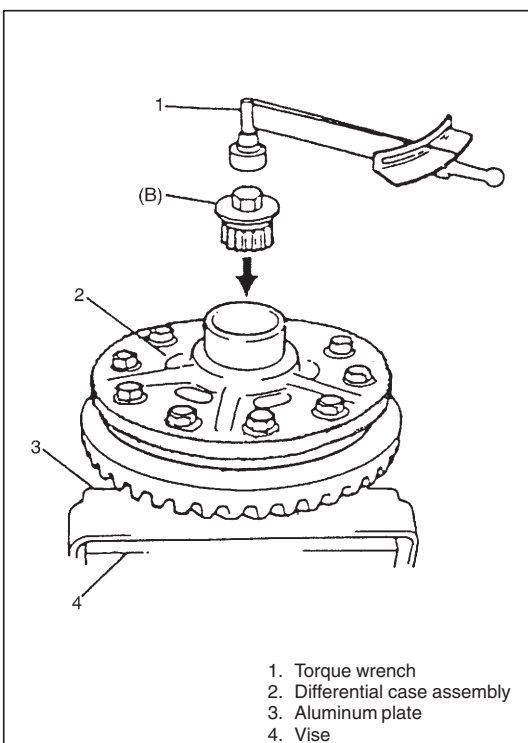

- 9) Install special tool to differential case assembly and check that preload is within specification below. If preload exceeds specified value, check if foreign matter is caught or gear is damaged.

Special tool

(B): 09928-06510

Side gear preload

: Max. 2.5 N·m (0.25 kg-m, 1.8 lb-ft)

1. Torque wrench
2. Differential case assembly
3. Aluminum plate
4. Vise

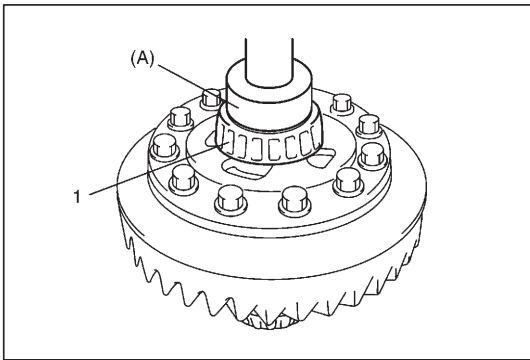

DIFFERENTIAL SIDE BEARING

1) Press-fit side bearing (1) with special tool and press.

Special tool
(A): 09944-66020

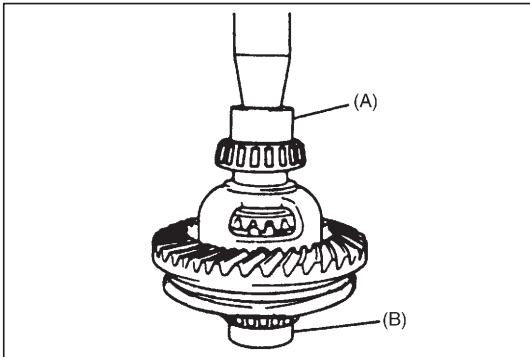

2) Hold bearing press-fitted in Step 1) with holder and press-fit side bearing on the other side.

NOTE:
Be sure to use bearing holder for the purpose of protecting lower bearing.

Special tool
(A): 09944-66020
(B): 09951-16060

DRIVE BEVEL PINION

To engage drive bevel pinion and gear correctly, it is pre-required to install drive bevel pinion to differential carrier properly by using adjusting shim as described on the followings. Shown below is relative positions of drive bevel pinion, differential carrier and mounting dummy.

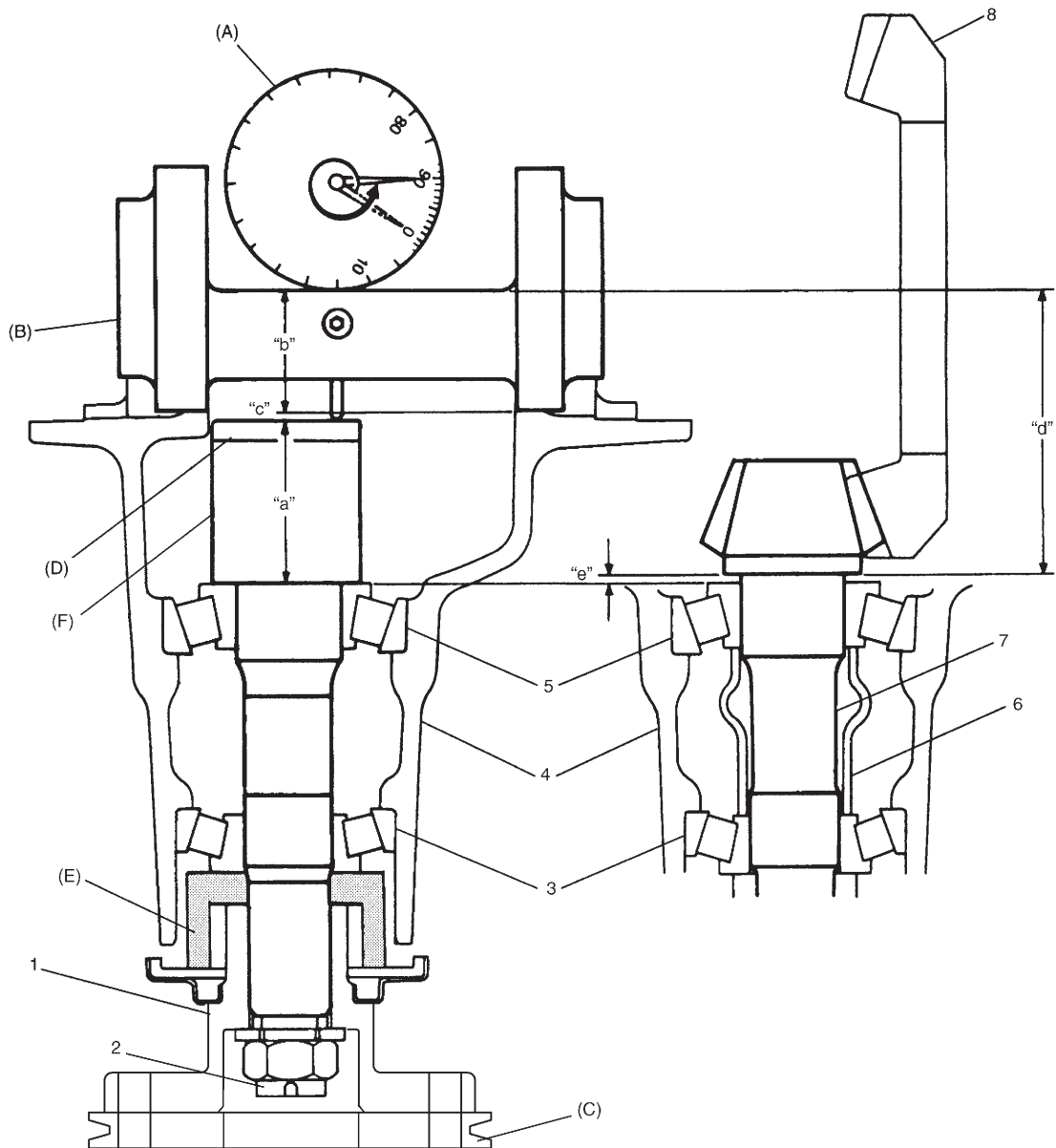
(A): 09900-20606**(B): 09926-78320****(C): 09922-75222****(D): 09922-76570****(E): 09951-46010****(F): 09926-78311-002**

1. Universal Joint flange (P/No. 27110-60A00)
2. Nut
3. Front bearing
4. Differential carrier
5. Rear bearing
6. Spacer
7. Drive bevel pinion
8. Drive bevel gear

- "a": Pinion dummy height + Attachment height
 "b": Axle dummy radius
 "a" + "b": Mounting dummy size 110.00 mm / 4.3307 in.
 "c": Measured dimension
 "d": Drive bevel pinion mounting distance 110.00 mm / 4.3307 in.
 "e": Shim size for mounting distance adjustment (= "c")

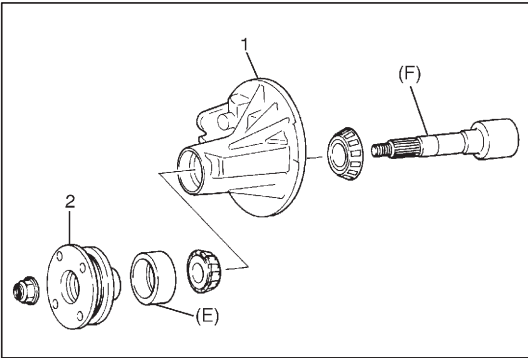

- 1) Install special tools with bearings and universal joint flange (2) to differential carrier (1).

NOTE:

This installation requires no spacer or oil seal.

Special tool

(E): 09951-46010

(F): 09926-78311-002

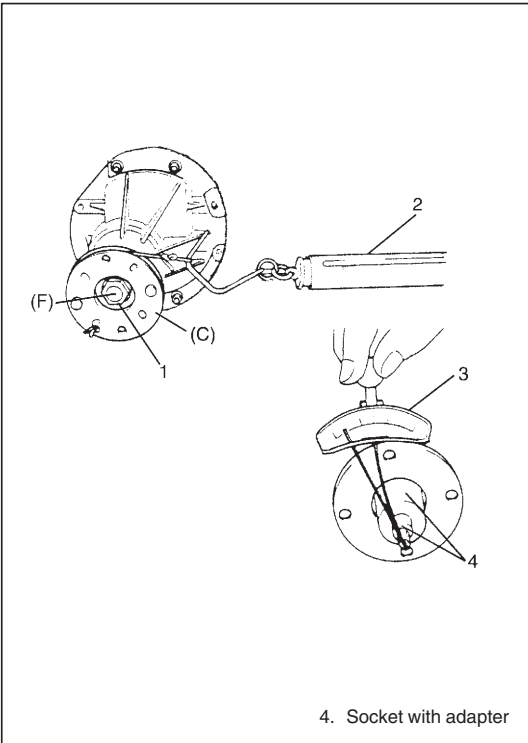

- 2) Tighten flange nut (1) so that specified bearing preload is obtained.

NOTE:

- Before taking measurement with spring balance (2) or torque wrench (3), check for rotation by hand and apply small amount of differential oil to bearings.

- On measuring preload, rotate the drive bevel pinion about 1 rotation per 2 seconds.

Special tool

(C): 09922-75222

(F): 09926-78311-002

Pinion bearing preload:

0.9 – 1.7 N·m (9.0 – 17.0 kg-cm, 7.8 – 14.7 lb-in.)

Spring measure reading with special tool:

18 – 34 N (1.8 – 3.4 kg, 4.0 – 7.5 lb)

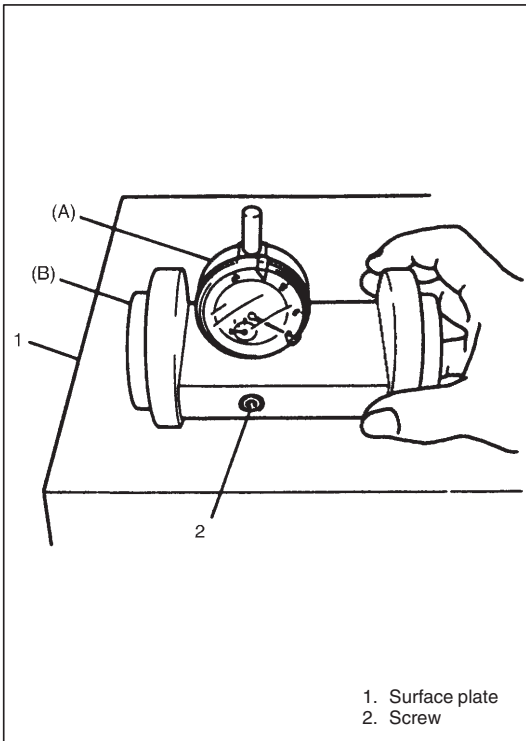

- 3) Set dial gauge to mounting dummy and make 0 (zero) adjustment on surface plate.

NOTE:

- When setting dial gauge to mounting dummy, tighten screw lightly. Be careful not to overtighten it, which will cause damage to dial gauge.
- With dial gauge set, turn dummy back and force by hand a couple of times and attain accurate 0 (zero) adjustment.
- It is desirable that short pointer indicates beyond 2 mm when long one is at 0 (zero).

Special tool

(A): 09900-20606

(B): 09926-78320

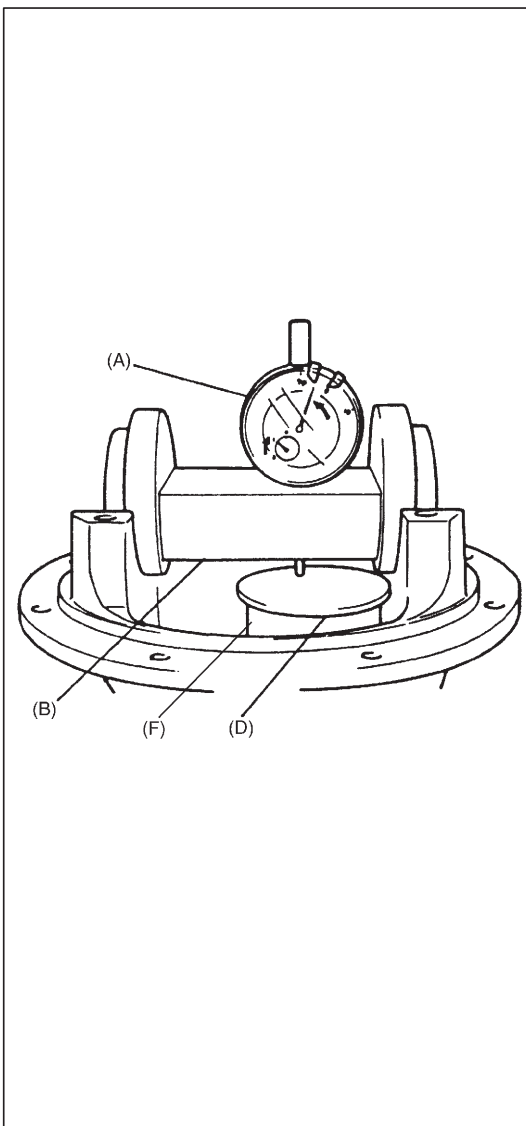

- 4) Place zero-adjusted mounting dummy and dial gauge set on pinion mounting dummy and take measurement between zero position and extended dial gauge measuring tip.

NOTE:

- Repeat turning back and force of dummy and measure distance as far as top surface of pinion dummy accurately.
- When dial gauge measuring tip extends from 0 (zero) position, pointer turns counterclockwise.
- Measured value may exceed 1 mm. Therefore, it is also necessary to know reading of short pointer.

Special tool

(A): 09900-20606

(B): 09926-78311

(D): 09922-76570

(F): 09926-78311-002

- 5) Obtain adjusting shim thickness by using measured value by dial gauge in previous step.

Necessary shim thickness "e"	=	Dial gauge measured value "c"
------------------------------	---	-------------------------------

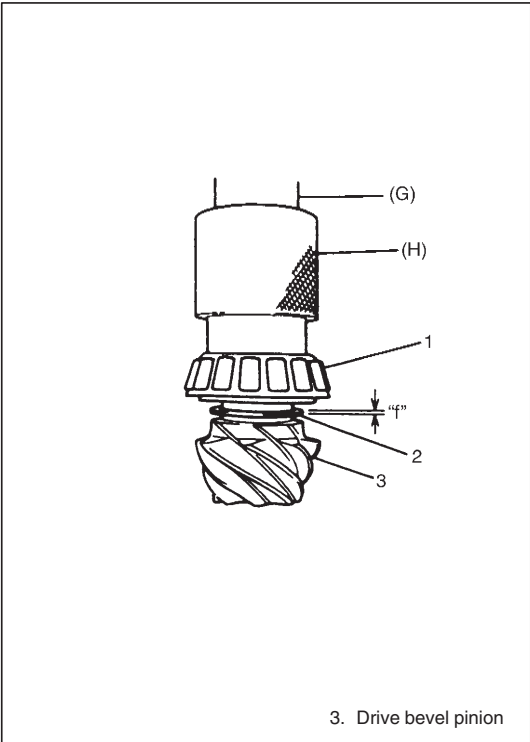

6) Select adjusting shim(s) (2) closest to calculated value from among following available sizes and put it in place and then press-fit rear bearing (1).

Calculated value “f”:
Closest value to “e” (refer to Step 5).

Special tool
(G): 09925-18011
(H): 09927-66010

Available shim thickness:
1.12, 1.15, 1.18, 1.21, 1.24, 1.27, 1.30 and 0.3 mm
(0.044, 0.045, 0.046, 0.047, 0.048, 0.049, 0.050 and 0.012 in.)

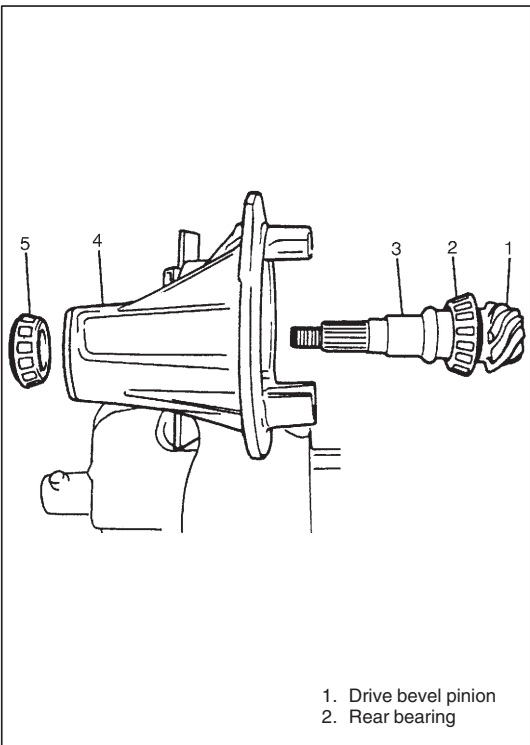

7) With new pinion spacer (3) inserted as shown in the figure, install front bearing (5) to differential carrier (4).

NOTE:

- Make sure to use new spacer for reinstallation.
- Apply differential oil to bearings.

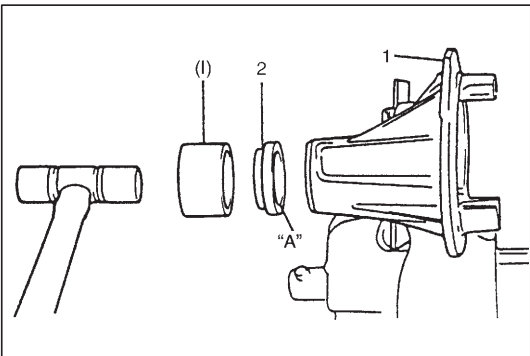

8) Using special tool and plastic hammer, drive oil seal (2) into differential carrier (1) till it becomes flush with carrier end. Then apply grease “A” to oil seal lip.

“A”: Grease 99000-25010

Special tool
(I): 09951-18210

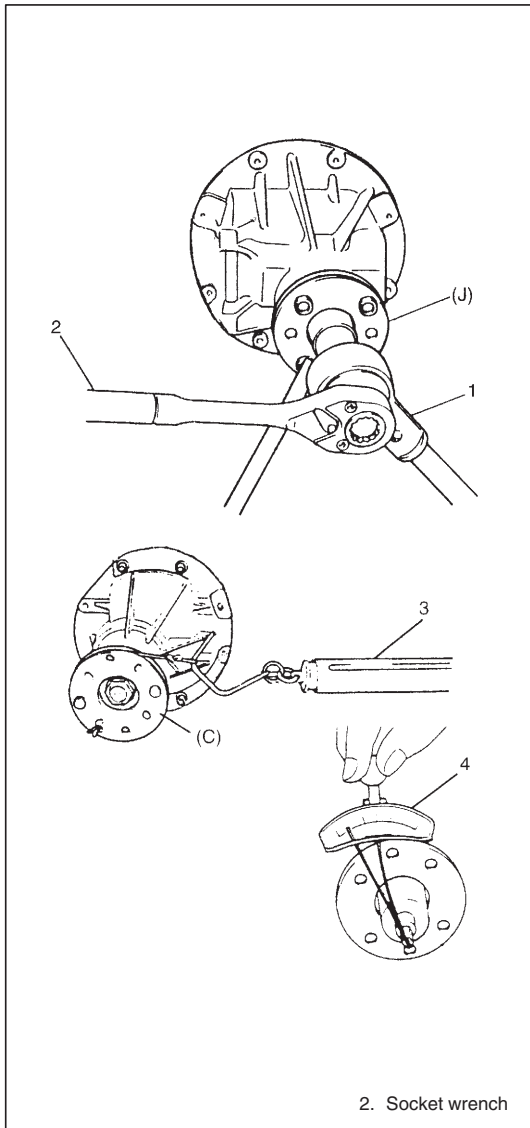

- 9) While tightening flange nut gradually with special tool and power wrench (4 – 10 magnification) (1), set preload of pinion to specification.

NOTE:

- Before taking measurement with spring balance (3) or torque wrench (4), check for smooth rotation by hand.
- On measuring preload, rotate the drive bevel pinion about 1 rotation per 2 seconds.
- Be sure to tighten gradually and carefully till specified starting torque is obtained. Turning back overtightened flange nuts should be avoided.

Pinion bearing preload:

0.9 – 1.7 N·m (9.0 – 17.0 kg-cm, 7.8 – 14.7 lb-in.)

Spring measure reading with special tool:

16 – 30 N (1.6 – 3.0 kg, 3.5 – 6.6 lb)

Special tool

(C): 09922-75222

(J): 09922-66021

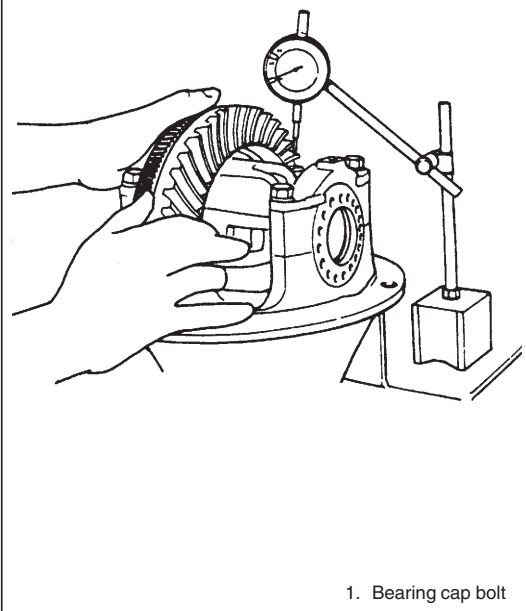
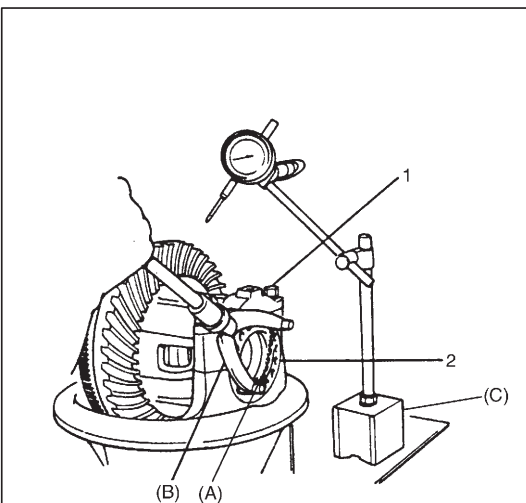
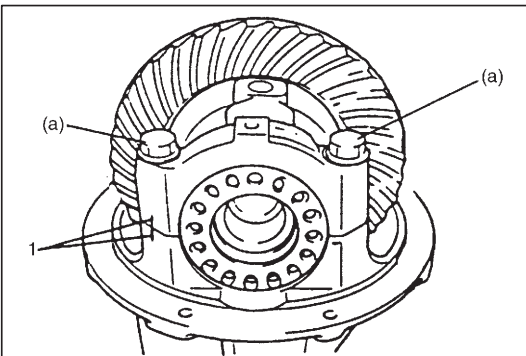
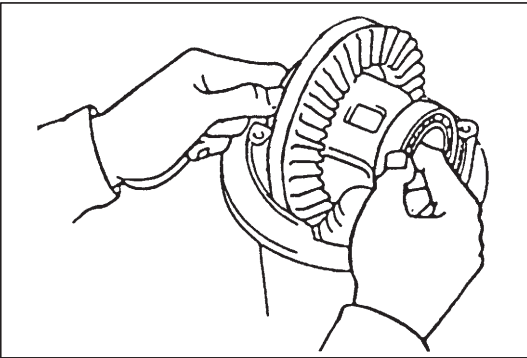

1. Bearing cap bolt

ASSEMBLING UNIT

- 1) Place bearing outer races on their respective bearings.
Used left and right outer races are not interchangeable.
- 2) Install case assembly in carrier.
- 3) Install side bearing adjusters on their respective carrier, making sure adjuster are threaded properly.

- 4) Align match marks (1) on cap and carrier. Screw in 2 side bearing cap bolts 2 or 3 turns and press down bearing cap by hand.

NOTE:

If bearing cap does not fit tightly on carrier, side bearing adjuster is not threaded properly. Reinstall adjuster.

- 5) Tighten cap bolts (provisional torque).

Tightening torque

Bearing cap bolt (Provisional torque) (a):
15 N·m (1.5 kg·m, 11.0 lb·ft)

- 6) Tighten both bearing adjusters (2) so as to obtain specified gear backlash and at the same time, obtain preload of side bearing.

NOTE:

- Be sure to apply measuring tip of dial gauge at right angles to convex side of tooth.
- As a practical measure the following would be recommended to obtain specified backlash and side bearing preload at the same time.
 - Obtain specified backlash by turning both adjusters inward lightly.
 - Tighten both adjusters further by one notch at a time.
- Measure at least 4 points on drive bevel gear periphery.

Standard backlash:

0.13 – 0.18 mm (0.005 – 0.007 in.)

Special tool

(A): 09930-40120

(B): 09930-40113

(C): 09900-20701

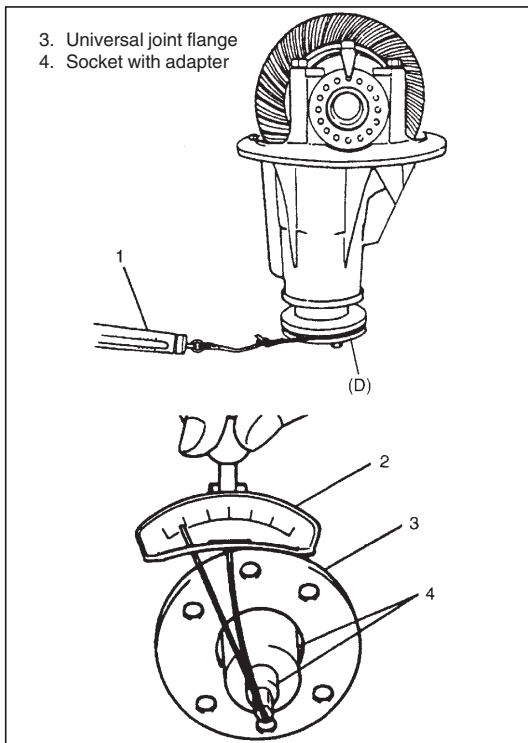

- 7) Measure preload of pinion bearing with spring balance (1) or torque wrench (2) and check composite preload of pinion bearing and side bearing.

NOTE:

- Before taking measurement with spring balance (1) or torque wrench (2), check for smooth rotation by hand.
- On measuring preload, rotate the drive bevel pinion about 1 rotation per 2 seconds.

Composite preload of pinion bearing and side bearing:

1.1 – 2.0 N·m (11.0 – 20.0 kg-cm, 9.5 – 17.4 lb-in.)

Spring measure reading with special tool:

19.5 – 35.5 N (1.95 – 3.55 kg, 4.30 – 7.83 lb)

Special tool

(D): 09922-75222

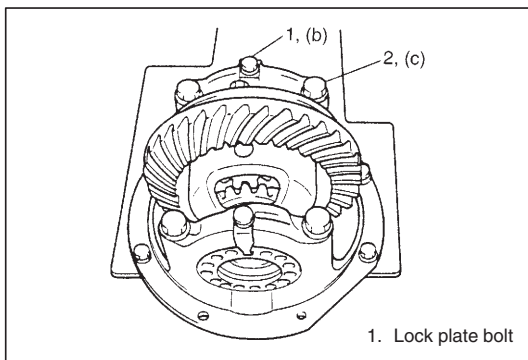

- 8) Torque bearing cap bolts (2) to specification and install bearing lock plates.

Tightening torque

Lock plate bolt (b): 12 N·m (1.2 kg-m, 9.0 lb-ft)

Bearing cap bolt (c): 85 N·m (8.5 kg-m, 61.5 lb-ft)

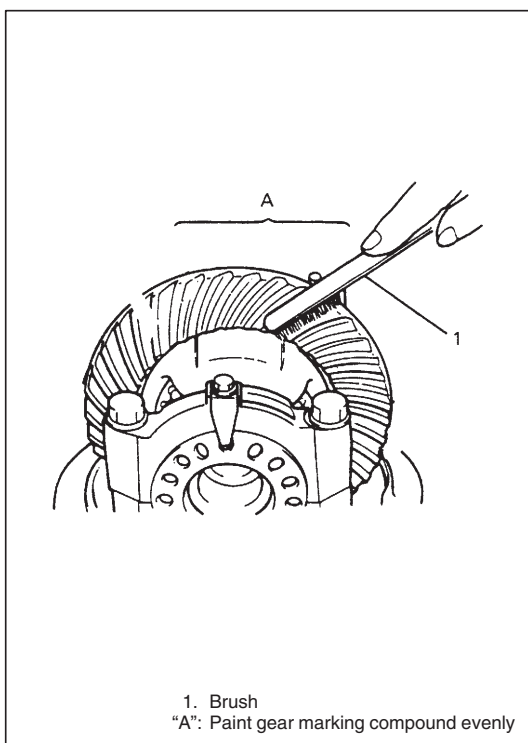





- 9) As final step, check gear tooth contact as follows.

- After cleaning 10 drive bevel gear teeth, paint them with gear marking compound evenly by using brush or sponge etc.
- Turn gear to bring its painted part in mesh with drive bevel pinion and turn it back and forth by hand to repeat their contact.
- Bring painted part up and check contact pattern, referring to following chart. If contact pattern is not normal, readjust or replace as necessary according to instruction in chart.

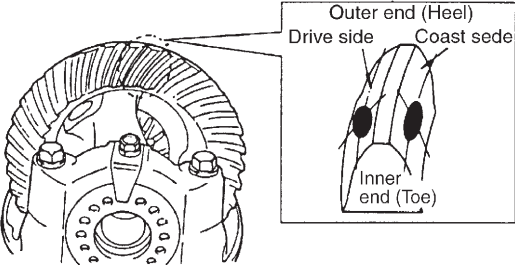
NOTE:

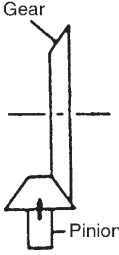
Be careful not to turn drive bevel gear more than one full revolution, for it will hinder accurate check.

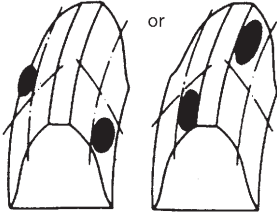
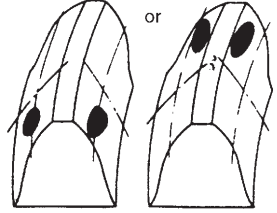
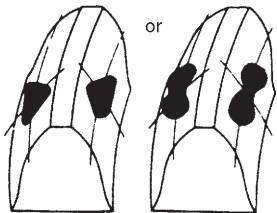
TOOTH CONTACT PATTERN	DIAGNOSIS AND REMEDY	
	<p>NORMAL</p>	
	<p>HIGH CONTACT Pinion is positioned too far from the center of drive bevel gear.</p> <ol style="list-style-type: none"> 1) Increase thickness of pinion height adjusting shim and position pinion closer to gear center. 2) Adjust drive bevel gear backlash to specification. 	
	<p>LOW CONTACT Pinion is positioned too close to the center of drive bevel gear.</p> <ol style="list-style-type: none"> 1) Decrease thickness of pinion height adjusting shim and position pinion farther from gear center. 2) Adjust drive bevel gear backlash to specification. 	
	<p>If adjustment is impossible, replace differential carrier.</p>	
	<ol style="list-style-type: none"> 1) Check seating of bevel gear or differential case. (Check bevel gear for runout). 2) If adjustment is impossible, replace drive bevel gear & pinion set or differential carrier. 	
	<p>Replace drive bevel gear & pinion set or differential case.</p>	

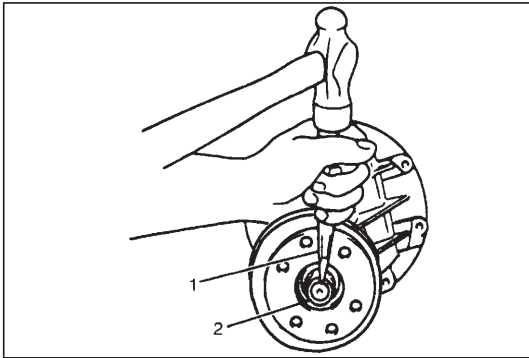

- 10) Upon completion of gear tooth contact check in Step 9), caulk flange nut (2) with caulking tool (1) and hammer.



TIGHTENING TORQUE SPECIFICATION

Fastening part	Tightening torque		
	N·m	kg·m	lb·ft
Differential oil level/filler plug	50	5.0	36.5
Differential oil drain plug	28	2.8	20.5
Propeller shaft flange bolts	60	6.0	43.5
Differential carrier bolts	55	5.5	40.0
Bevel gear bolts	95	9.5	68.5
Bearing cap bolts	85	8.5	61.5
Lock plate bolts	12	1.2	9.0
Differential case screws	9	0.9	6.5

REQUIRED SERVICE MATERIAL

Material	Recommended SUZUKI product (Part Number)	Use
Thread lock cement	THREAD LOCK CEMENT SUPER 1322 (99000-32110)	<ul style="list-style-type: none"> ● Bevel gear bolts ● Differential case bolts ● Bevel gear mating surface ● Propeller shaft flange bolt
Lithium grease	SUZUKI SUPER GREASE A (99000-25010)	Oil seal lips
Sealant	SUZUKI BOND NO.1215 (99000-31110)	<ul style="list-style-type: none"> ● Rear differential drain plug ● Mating surface of differential housing ● Mating surface of rear axle housing

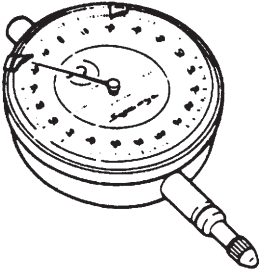
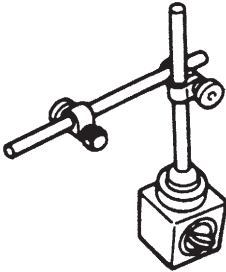
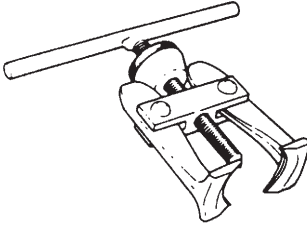
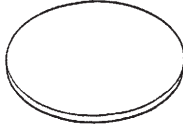
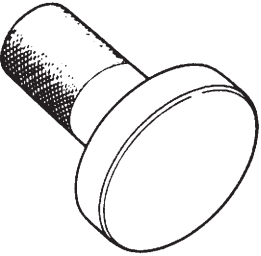
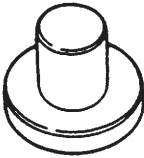
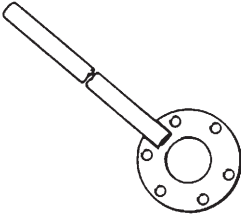
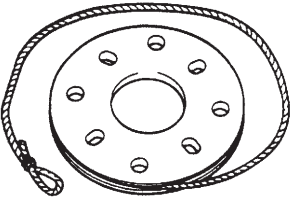
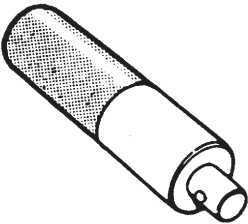
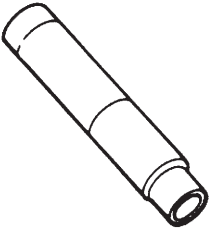
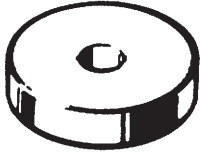
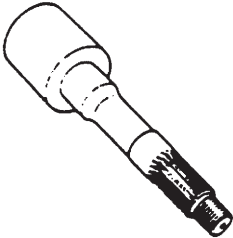
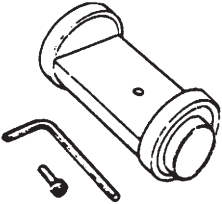
SPECIAL TOOL

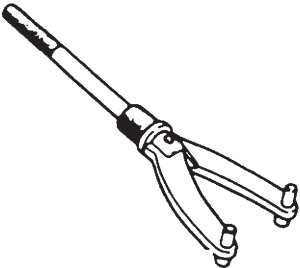
 <p>09900-20606 Dial gauge</p>	 <p>09900-20701 Magnetic stand</p>	 <p>09913-61510 Bearing puller</p>	 <p>09922-76570 Attachment</p>
 <p>09913-75510 Bearing installer</p>	 <p>09913-85230 Bearing removing jig</p>	 <p>09922-66021 Flange holder</p>	 <p>09922-75222 Preload checking tool</p>
 <p>09924-74510 Installer attachment</p>	 <p>09925-18011 Bearing installer</p>	 <p>09926-68310 Bearing installer</p>	 <p>09926-78311-002 Pinion mounting dummy (See NOTE.)</p>
 <p>09926-78320 Mounting dummy</p>	 <p>09927-66010/J-23082-01 Oil pump aligner</p>	 <p>09928-06510 Differential torque checking tool</p>	 <p>09930-40113 Rotor holder</p>

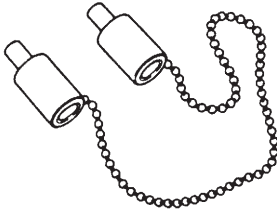
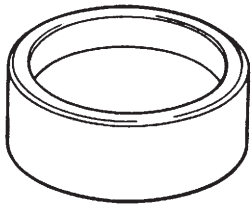
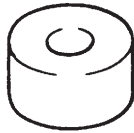
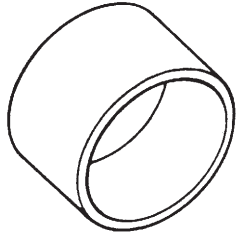
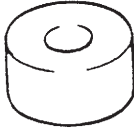
 <p>09930-40120 Attachment</p>	 <p>09944-66020 Bearing installer</p>	 <p>09951-16060 Lower arm bush remover</p>	 <p>09951-18210 Oil seal remover & installer No.2</p>
 <p>09951-46010 Drive shaft oil seal installer</p>			

NOTE:

This tool is constituent of tools with 09926-78311

SECTION 8C

INSTRUMENTATION/DRIVER INFORMATION

WARNING:

For vehicles equipped with Supplemental Restraint (Air Bag) System:

- Service on and around the air bag system components or wiring must be performed only by an authorized SUZUKI dealer. Refer to “Air Bag System Components and Wiring Location View” under “General Description” in air bag system section in order to confirm whether you are performing service on or near the air bag system components or wiring. Please observe all WARNINGS and “Service Precautions” under “On-Vehicle Service” in air bag system section before performing service on or around the air bag system components or wiring. Failure to follow WARNINGS could result in unintentional activation of the system or could render the system inoperative. Either of these two conditions may result in severe injury.
- Technical service work must be started at least 90 seconds after the ignition switch is turned to the “LOCK” position and the negative cable is disconnected from the battery. Otherwise, the system may be activated by reserve energy in the Sensing and Diagnostic Module (SDM).

NOTE:

For the descriptions (items) not found in this section of this manual, refer to the same section of the Service Manual mentioned in the FOREWORD of this manual.

CONTENTS

GENERAL DESCRIPTION	8C- 2
Combination Meter	8C- 2
ON-VEHICLE SERVICE	8C- 3
Fuel Meter/Fuel Gauge Unit	8C- 3
Engine Coolant Temperature Sensor (ECT Sensor)	8C- 3
Oil Pressure Switch	8C- 3

GENERAL DESCRIPTION

COMBINATION METER

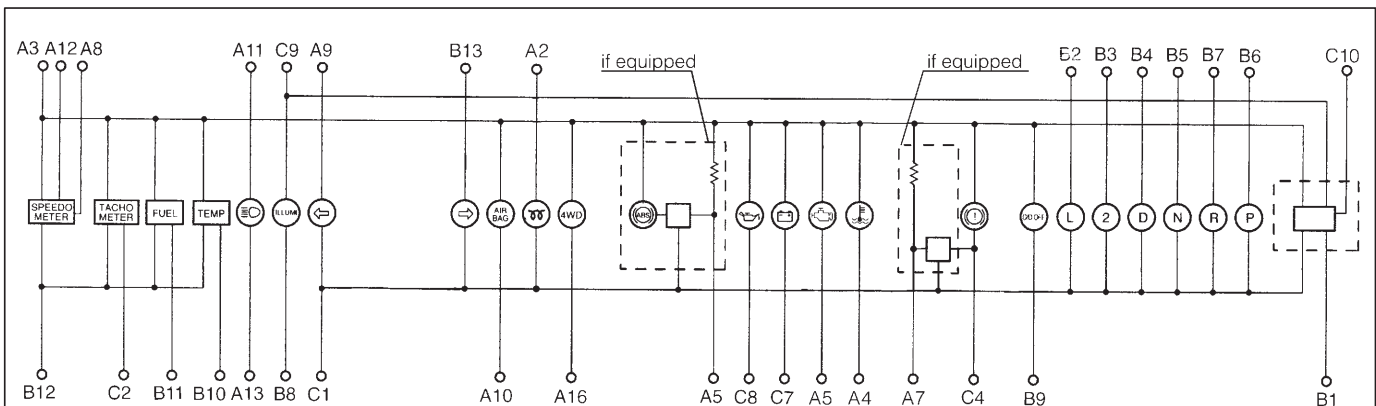
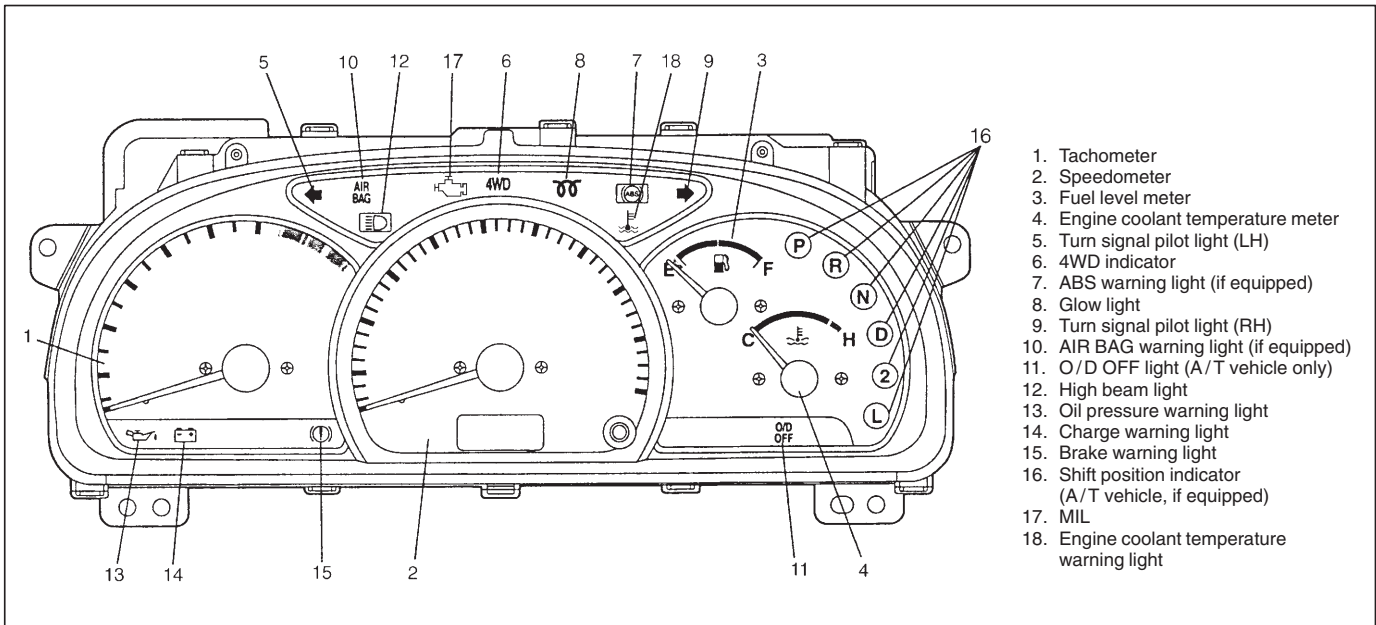

NOTE:
Terminal arrangement of coupler viewed from harness side.

Coupler A

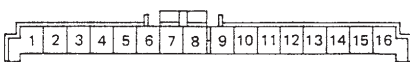

Coupler A

- | | |
|----------------------------------|-------|
| 1. Blank | — |
| 2. To ECM (PCM for A/T vehicle) | R/B |
| 3. To ignition switch | B/W |
| 4. To ECM (PCM for A/T vehicle) | Y/W |
| 5. To ABS control module | Bl/Or |
| 6. Blank | — |
| 7. To ABS control module | Br |
| 8. To VSS | Bl/Y |
| 9. To combination switch | G/R |
| 10. To SDM | Bl |
| 11. To main fuse | W/Bl |
| 12. To fuse box | W |
| 13. To combination switch | R |
| 14. Blank | — |
| 15. To ECM (PCM for A/T vehicle) | V/Y |
| 16. To ECM (PCM for A/T vehicle) | Or/B |

Coupler B

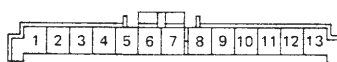

Coupler B

- | | |
|--|-------|
| 1. To door switch (driver side) | B/Bl |
| 2. To transmission range switch (A/T vehicle only) L | G/Bl |
| 3. To transmission range switch (A/T vehicle only) 2 | G/Or |
| 4. To transmission range switch (A/T vehicle only) D | Y/G |
| 5. To transmission range switch (A/T vehicle only) N | Or/Bl |
| 6. To transmission range switch (A/T vehicle only) P | Or/G |
| 7. To transmission range switch (A/T vehicle only) R | R |
| 8. To ground | B |
| 9. To PCM (A/T vehicle only) | W/B |
| 10. To ECT sensor | Y/W |
| 11. To fuel level gauge | Bl/W |
| 12. To ground | B |
| 13. To combination switch | G/Y |

Coupler C

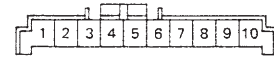

Coupler C

- | | |
|---|------|
| 1. To ground | B |
| 2. To ECM (PCM for A/T vehicle) | Br |
| 3. Blank | — |
| 4. To brake fluid level switch and parking brake switch | R/B |
| 5. Blank | — |
| 6. Blank | — |
| 7. To generator | W/R |
| 8. To oil pressure switch | Y/B |
| 9. To combination switch | R/Y |
| 10. To ignition switch | Bl/R |

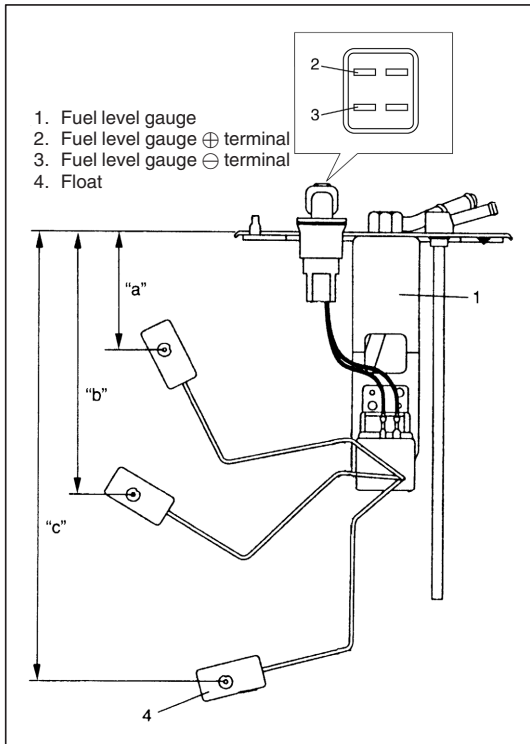

ON-VEHICLE SERVICE

FUEL METER/FUEL GAUGE UNIT FUEL LEVEL GAUGE

INSPECTION

Remove fuel sender gauge referring to Section 6C of this manual. Use an ohmmeter to confirm that resistance of sender gauge unit changes with change of float position.

	Float Position	Fuel Meter	Resistance (Ω)
"a"	51.7 mm (2.04 in.)	F	6 – 8
"b"	139.6 mm (5.50 in.)	1/2	29.5 – 35.5
"c"	254.9 mm (10.0 in.)	E	94 – 96

If measured value is out of specification, replace fuel sender gauge.

ENGINE COOLANT TEMPERATURE SENSOR (ECT SENSOR)

REMOVAL, INSPECTION AND INSTALLATION

Refer to ENGINE COOLANT TEMPERATURE SENSOR (ECT SENSOR) in Section 6E3.

OIL PRESSURE SWITCH

REMOVAL AND INSTALLATION

Refer to OIL PRESSURE SWITCH in Section 6A3 of this manual for details.

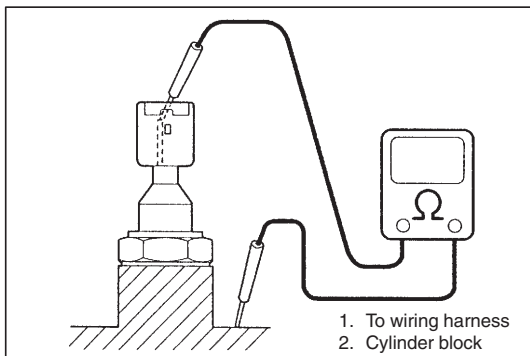

INSPECTION

Use an ohmmeter to check switch continuity.

During Engine Running	No continuity ($\infty \Omega$)
At Engine Stop	Continuity (0Ω)

SECTION 8G

IMMOBILIZER CONTROL SYSTEM (IF EQUIPPED)

WARNING:

For vehicles equipped with Supplemental Restraint (Air Bag) System:

- Service on and around the air bag system components or wiring must be performed only by an authorized SUZUKI dealer. Refer to “Air Bag System Components and Wiring Location View” under “General Description” in air bag system section in order to confirm whether you are performing service on or near the air bag system components or wiring. Please observe all WARNINGS and “Service Precautions” under “On-Vehicle Service” in air bag system section before performing service on or around the air bag system components or wiring. Failure to follow WARNINGS could result in unintentional activation of the system or could render the system inoperative. Either of these two conditions may result in severe injury.
- Technical service work must be started at least 90 seconds after the ignition switch is turned to the “LOCK” position and the negative cable is disconnected from the battery. Otherwise, the system may be activated by reserve energy in the Sensing and Diagnostic Module (SDM).

CONTENTS

GENERAL DESCRIPTION	8G- 2	DTC13 No Transponder Code Transmitted from Ignition Key	8G-12
Ignition Key	8G- 4	DTC14 Coil Antenna Circuit Malfunction .	8G-12
Coil Antenna	8G- 4	DTC41 ECM Not Registered	8G-13
Immobilizer Control Module	8G- 4	DTC42 Serial Data Circuit Malfunction ..	8G-14
ECM	8G- 4	DTC43 ECU Code Not Matched	8G-15
On-board Diagnostic System (Self-diagnosis function)	8G- 5	Inspection of Immobilizer Control Module and Its Circuit	8G-16
DIAGNOSIS	8G- 6	Voltage Check	8G-16
Precautions in Diagnosing Troubles	8G- 6	Resistance Check	8G-17
Immobilizer Diagnostic Flow Table	8G- 7	ON-VEHICLE SERVICE	8G-18
Diagnostic Trouble Code (DTC) Check (Immobilizer Control Module)	8G- 8	Precautions in Handling Immobilizer Control System	8G-18
Diagnostic Trouble Code Table	8G- 9	Immobilizer Control Module	8G-19
TABLE A Scan Tool Can Not Communicate with Immobilizer Control Module	8G-10	Coil Antenna	8G-19
DTC11 Transponder Code Not Matched	8G-11	HOW TO REGISTER IGNITION KEY	8G-20
DTC31 Transponder Code Not Registered	8G-11	PROCEDURE AFTER IMMOBILIZER CONTROL MODULE REPLACEMENT ..	8G-21
DTC12 Fault in Immobilizer Control Module	8G-11	PROCEDURE AFTER ECM REPLACEMENT	8G-22
		SPECIAL TOOLS	8G-23

GENERAL DESCRIPTION

The immobilizer control system is designed to prevent vehicle burglar and consists of following components.

- Engine control module (ECM)
- Immobilizer Control Module
- Ignition key (with built-in transponder)
- Coil antenna

Operation of this system is as follows.

- (1) Each ignition key has its own Transponder code stored in memory. When the ignition switch is turned ON, Immobilizer Control Module tries to read the Transponder code through the coil antenna installed to the steering lock assembly.
- (2) Immobilizer Control Module compares the Transponder code read in (1) and that registered in Immobilizer Control Module and checks if they match.
- (3) When it is confirmed that two Transponder codes match in Step (2), Immobilizer Control Module and ECM check if ECU codes registered in them respectively match.
- (4) Only when it is confirmed that ECU codes match, engine can be started (immobilizer system unlocked).
If Transponder codes in Step (2) or ECU codes in Step (3) do not match, ECM will stop operation of the injectors.

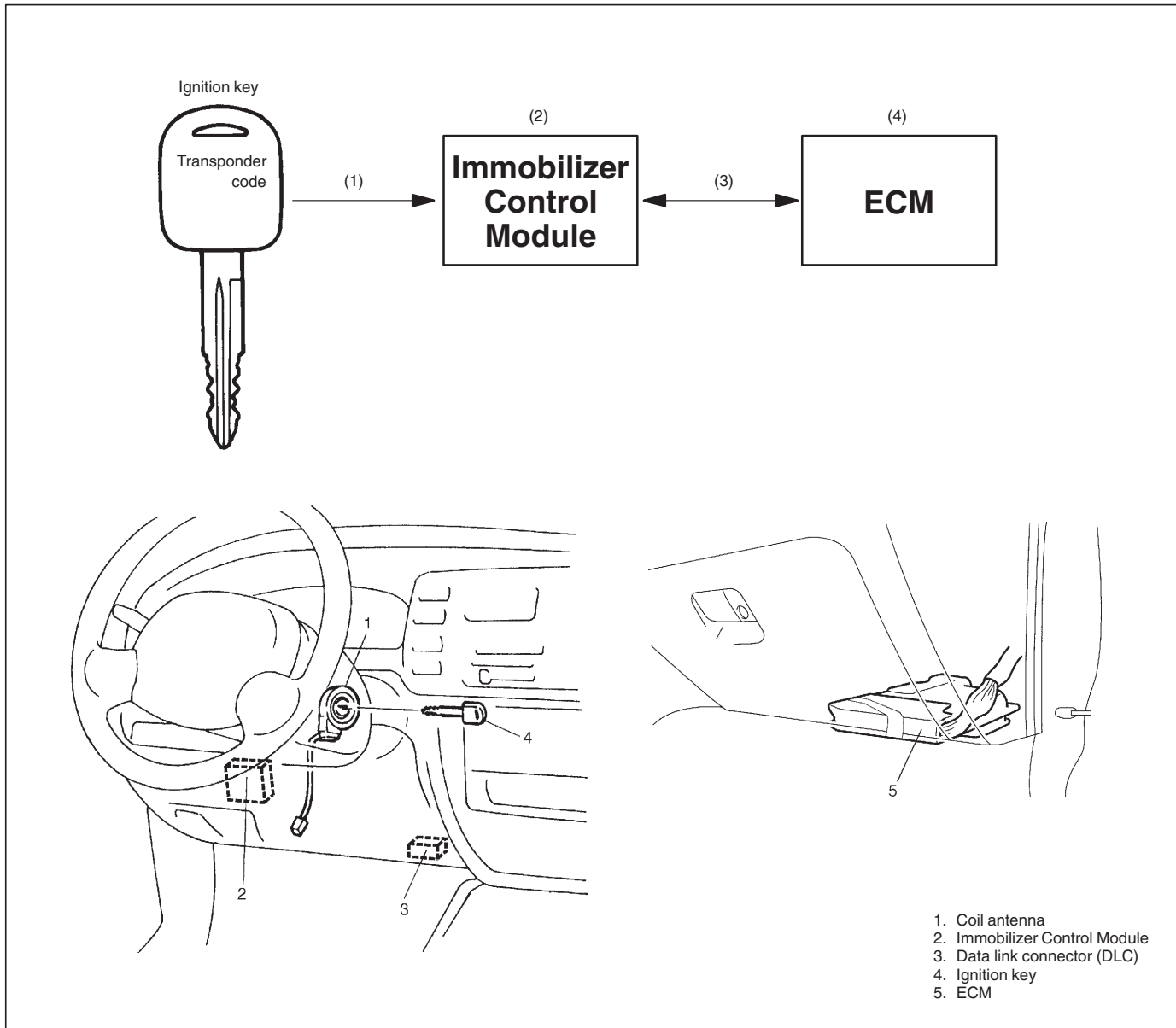

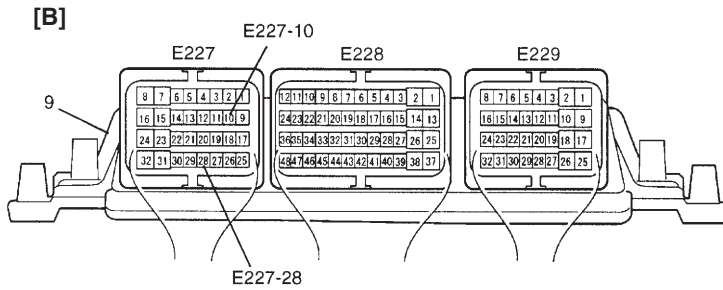
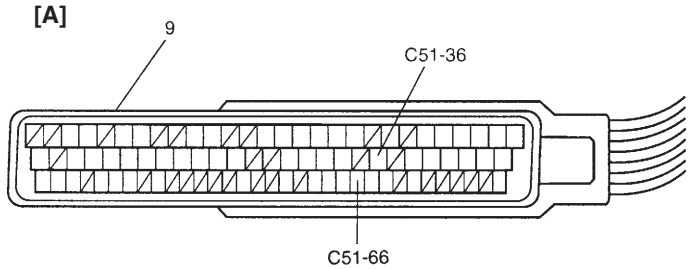
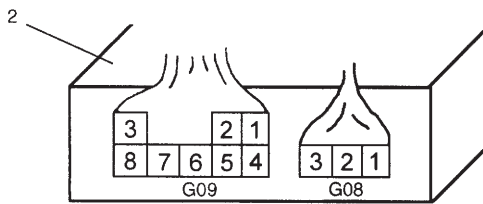
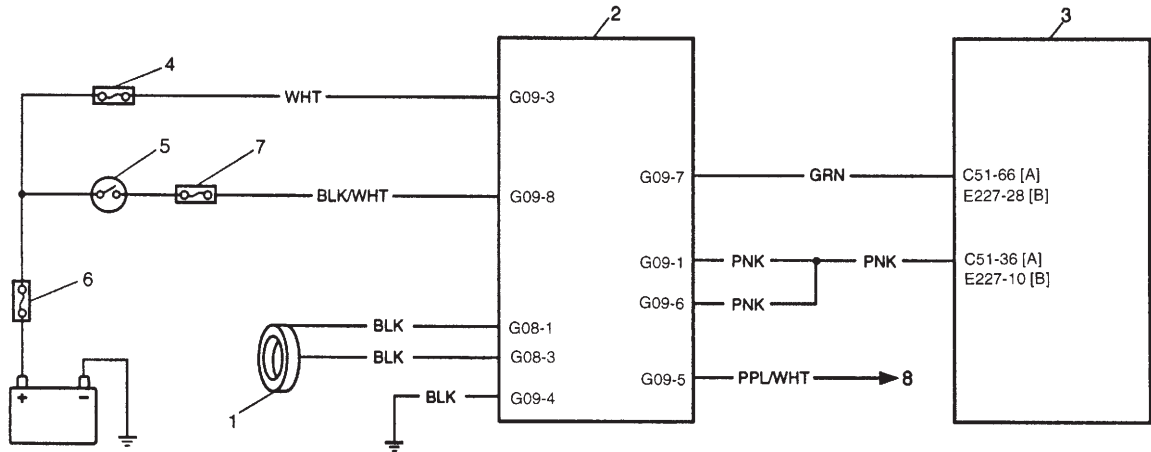

1. Coil antenna
 2. Immobilizer control module
 3. ECM
 4. "DOME" fuse
 5. Ignition switch
 6. Main fuse
 7. "IG METER" fuse
 8. To data link connector
 9. ECM connector (Viewed from terminal side)
- [A] : For vehicle equipped with single-connector ECM
 [B] : For vehicle equipped with triple-connector ECM

CONNECTOR	TERMINAL	WIRE COLOR	CIRCUIT
G08	1	BLK	Coil antenna +
	2	—	—
	3	BLK	Coil antenna -
G09	1	PNK	Serial data line between ECM and immobilizer control module
	2	—	—
	3	WHT	Power supply
	4	B	GND
	5	PPL/WHT	Serial data line for Suzuki scan tool
	6	PNK	Serial data line between ECM and immobilizer control module
	7	GRN	Power control of ECM
	8	BLK/WHT	Ignition signal

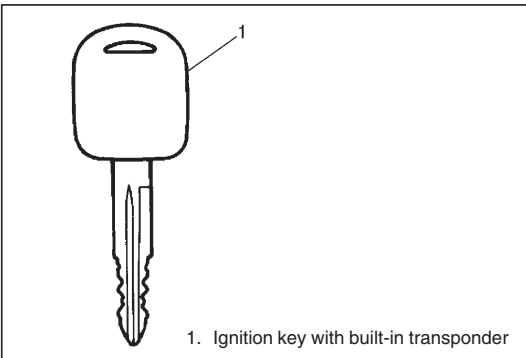

IGNITION KEY

The ignition key for the immobilizer control system has a built-in transponder. Each transponder in the key has an each transmitting code (Transponder code). The code will transmitted from the key via the coil antenna to Immobilizer Control Module when the ignition switch is turned ON.

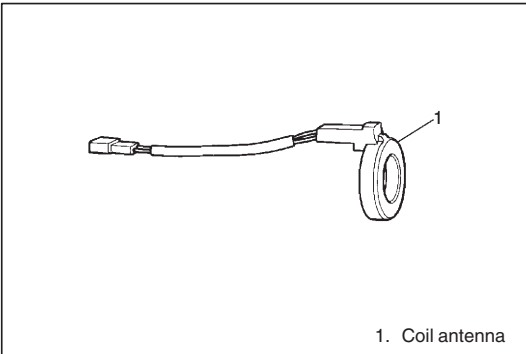

COIL ANTENNA

The coil antenna is installed to the steering lock assembly. As it is energized by Immobilizer Control Module, it transmits the transponder code of the ignition key to Immobilizer Control Module.

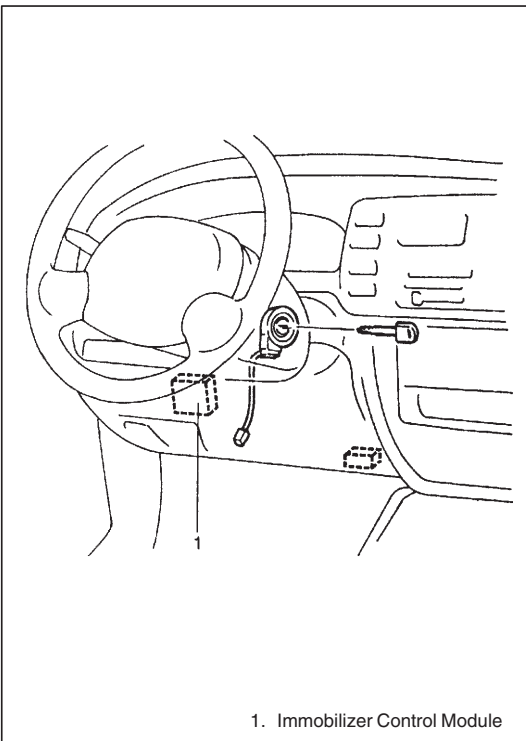

IMMOBILIZER CONTROL MODULE

Immobilizer Control Module is installed to the underside of the instrument panel at the driver's seat side.

As main functions, Immobilizer Control Module checks matching not only between the Transponder Code transmitted from the ignition key and that registered in Immobilizer Control Module (Up to 4 different Transponder codes can be registered.) but also between the ECU code transmitted from ECM and that registered in Immobilizer Control Module. In addition, it has an on-board diagnostic system (self-diagnosis function) which is described in the following page.

ECM

ECM checks matching of ECU code transmitted from immobilizer control module and ECU code registered in ECM. After confirmation of ECU codes, ECM is ready to start engine.

ON-BOARD DIAGNOSTIC SYSTEM (SELF-DIAGNOSIS FUNCTION)

Immobilizer Control Module and ECM diagnoses troubles which may occur in the area including the following parts when the ignition switch is ON. It indicates the diagnosis result through Suzuki scan tool.

- Immobilizer Control Module: ● Ignition key (Transponder code)
- Coil antenna
- Serial data circuit between Immobilizer Control Module and ECM
- Immobilizer Control Module (Transponder code or ECU code)
- ECM (ECU code)

DIAGNOSIS

Immobilizer Control Module have on-board diagnostic system (a system self-diagnosis function) as described previously.

Investigate where the trouble is by referring to “IMMOBILIZER DIAGNOSTIC FLOW TABLE” and “DIAGNOSTIC TROUBLE CODE TABLE” on later pages.

PRECAUTIONS IN DIAGNOSING TROUBLES

[PRECAUTIONS IN IDENTIFYING DIAGNOSTIC TROUBLE CODE]

Immobilizer Control Module

- Take a note of diagnostic trouble code indicated first.

[NOTES ON SYSTEM CIRCUIT INSPECTION]

Refer to “Precautions for Electrical Circuit Service” and “Intermittents and Poor Connection” in Section 0A.

[Precaution after replacing ECM or Immobilizer Control Module]

- When ECM was replaced the ECM codes must be registered in ECM and Immobilizer Control Module by performing procedure described in “Procedure after ECM Replacement” in this section. If it is not registered, ECM would not function as Immobilizer Control System and accurate trouble diagnosis would not be assured.
- When Immobilizer Control Module was replaced, including when replaced because rechecking by using a known-good Immobilizer Control Module was necessary during trouble diagnosis, the Transponder code and ECM code must be registered in Immobilizer Control Module by performing procedure described in “Procedure after Immobilizer Control Module Replacement” in this section. If they are not registered, the engine would not start and accurate trouble diagnosis would not be assured.

IMMOBILIZER DIAGNOSTIC FLOW TABLE**NOTE:**

After replacing with Immobilizer Control Module and/or ECM, register transponder code and ECU code according to “Procedure after Immobilizer Control Module Replacement” or “Procedure after ECM Replacement”. Otherwise, the accurate trouble diagnosis will not be assured.

STEP	ACTION	YES	NO
1	Turn ignition switch to start engine. Dose engine run?	Immobilizer control system is in good condition.	Go to Step 2.
2	Check DTC stored in immobilizer control module referring to “DIAGNOSTIC TROUBLE CODE CHECK”. Are there DTC Nos 13 and/or 14?	Go to flow table for DTC No.	Go to Step 3.
3	Is there DTC No.12?	Go to flow table for DTC No.	Go to Step 4.
4	Are there DTC Nos 11 and/or 31?	Go to flow table for DTC No.	Go to Step 5.
5	Are there DTC No.41, 42 or 43?	Go to flow table for DTC No.	Substitute a known-good immobilizer control module. And then go to Step 6.
6	Turn ignition switch to start engine. Dose engine run?	Immobilizer control system is in good condition.	If vehicle is equipped with single-connector ECM, proceed to “ENGINE DIAGNOSIS TABLE” in Section 6. And if vehicle is equipped with triple-connector ECM, Proceed to “ENGINE DIAGNOSIS TABLE” in Section 6-1.

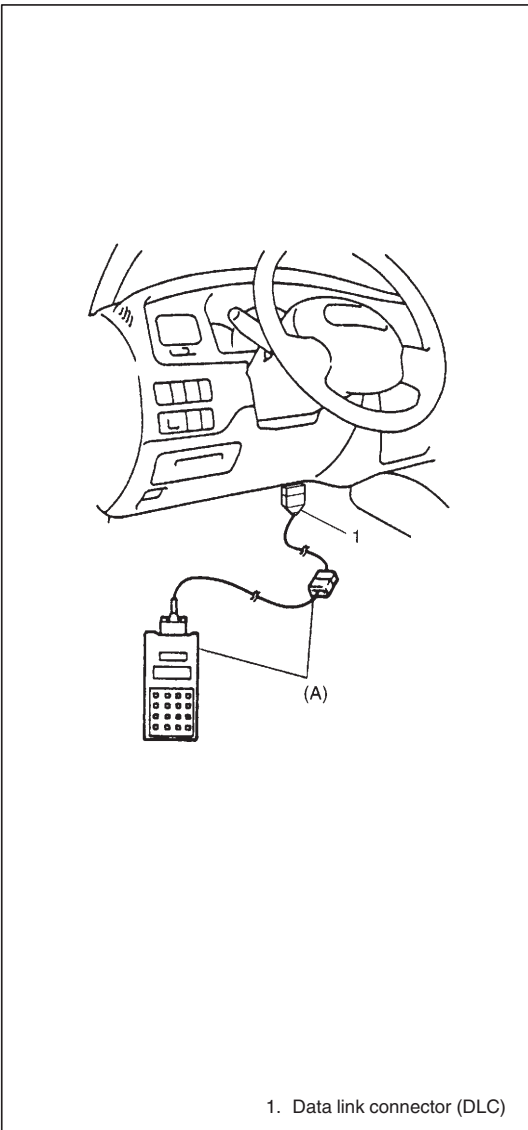

DIAGNOSTIC TROUBLE CODE (DTC) CHECK (IMMOBILIZER CONTROL MODULE)

- 1) Turn ignition switch OFF.
- 2) After setting cartridge to Suzuki scan tool, connect it to data link connector (DLC) located on underside of instrument panel at driver's seat side.

Special Tool

(A): Suzuki scan tool

- 3) Turn ignition switch OFF for 10 seconds and then ON.

NOTE:

When the ignition switch is turned off and then on again within 10 seconds, DTC41 is stored in the immobilizer control module.

- 4) Read DTC stored in immobilizer control module according to instructions displayed on Suzuki scan tool and print it or write it down. Refer to Suzuki scan tool operator's manual for further details.

If Suzuki scan tool indicates "ECU NO RESPONSE", go to "Diagnostic Flow Table A".

NOTE:

When reading DTC stored in immobilizer control module using Suzuki scan tool, select "BCM" from the applications menu and "IMMOBILIZER" from the select system menu displayed on Suzuki scan tool.

- 5) After completing the check, turn ignition switch OFF and disconnect Suzuki scan tool from data link connector (DLC).

DIAGNOSTIC TROUBLE CODE TABLE**Immobilizer Control Module**

DIAGNOSTIC TROUBLE CODE NO.	DETECTED ITEM	DIAGNOSIS
NO DTC	—	This code appears when none of the other codes are identified.
11	Transponder code not matched	Diagnose trouble according to “DIAGNOSTIC FLOW TABLE” corresponding to each code No.
31	Transponder code not registered	
12	Fault in Immobilizer Control Module	
13	No transponder code transmitted from ignition key	
14	Coil antenna circuit malfunction	
41	ECM not registered	
43	ECU code not matched	
42	Serial data circuit (between Immobilizer Control Module and ECM)	

NOTE:

- When the ignition switch is turned off and then on again within 10 seconds, DTC 41 is stored in the immobilizer control module.
- If any DTC other than DTC 41 is stored in the immobilizer control module, the immobilizer system is locked (engine unable to start).

TABLE A SCAN TOOL CAN NOT COMMUNICATE WITH IMMOBILIZER CONTROL MODULE

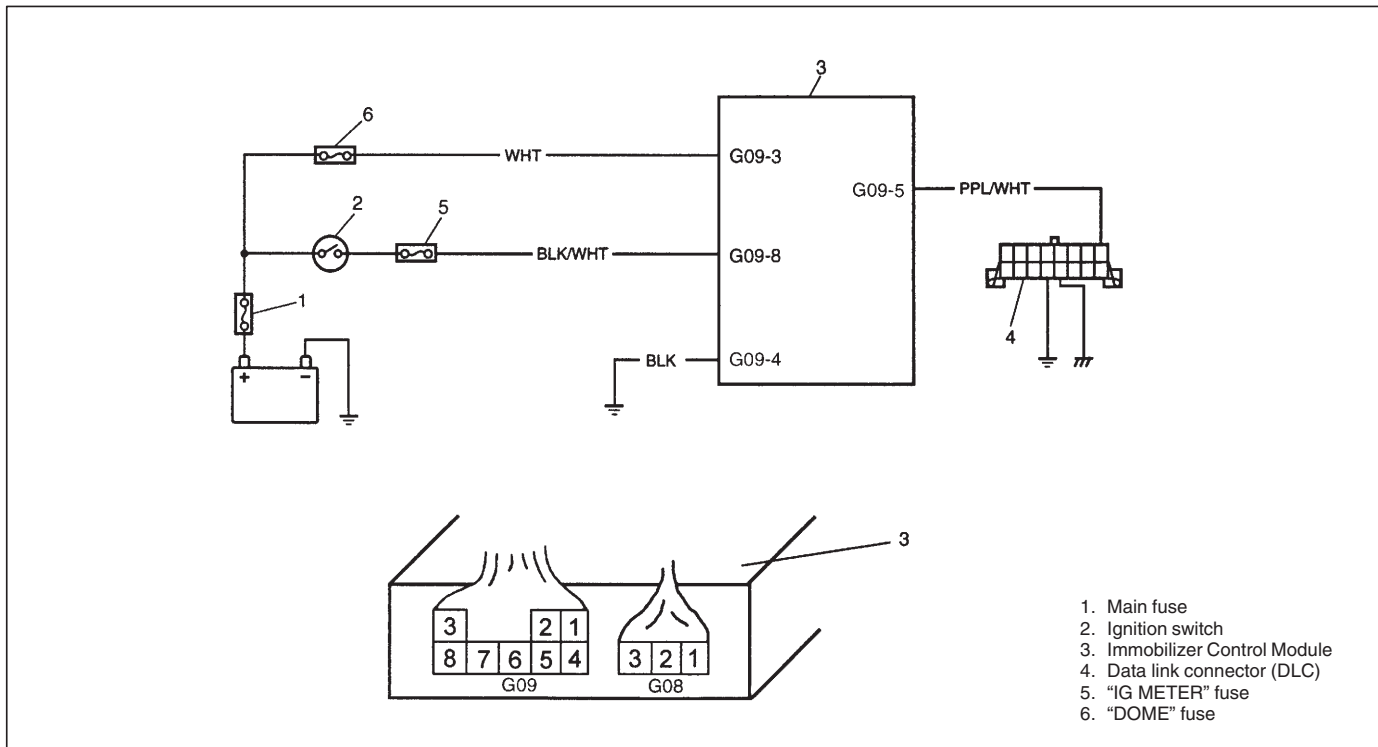

STEP	ACTION	YES	NO
1	Check voltage between G09-8 terminal and body ground with ignition switch ON. Is it 10 – 14 V?	Go to Step 2.	<ul style="list-style-type: none"> ● "BLK/WHT" wire open ● "IG METER" fuse broken
2	Check voltage between G09-3 terminal and body ground. Is it 10 – 14 V?	Go to Step 3.	<ul style="list-style-type: none"> ● "WHT" wire open ● "DOME" fuse broken
3	Is there continuity between G09-4 terminal and body ground?	Go to Step 4.	"BLK" wire open
4	Check voltage between "PPL/WHT" wire terminal of DLC and body ground with ignition switch ON. Is it 4 – 5 V?	<ul style="list-style-type: none"> ● Poor G09-8, G09-3, G09-4 or G09-5 connection If connection and line are OK, substitute a known-good Immobilizer Control Module and recheck.	"PPL/WHT" wire open

DTC11 TRANSPONDER CODE NOT MATCHED DTC31 TRANSPONDER CODE NOT REGISTERED

DESCRIPTION:

Immobilizer Control Module checks if Transponder code transmitted from ignition key and that registered in Immobilizer Control Module match when ignition switch is ON. If they do not, DTC 11 and 31 are set.

INSPECTION:

STEP	ACTION	YES	NO
1	Was "Immobilizer Diag. Flow Table" performed?	Go to Step 2.	Go to "Immobilizer Diag. Flow Table".
2	Check that knob shape of ignition key being used is the same as shown in Fig. 1. Is it ignition key with built-in transponder?	Register ignition key in immobilizer control module according to the procedure described in "How to Register Ignition Key". And then go to Step 3.	Replace ignition key.
3	Read DTC according to "Diagnostic Trouble Code Check" section. Does Suzuki scan tool indicate DTC 11 and/or 31 again?	Replace ignition key.	Go to "Immobilizer Diag. Flow Table".

Fig. 1 for Step 2

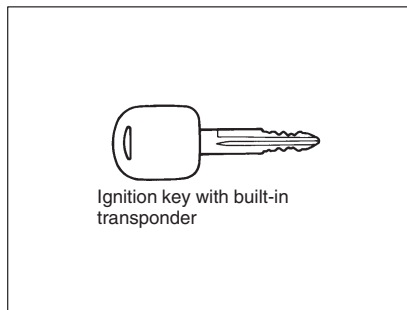

DTC12 FAULT IN IMMOBILIZER CONTROL MODULE

DESCRIPTION:

This DTC is set when an internal fault is detected in Immobilizer Control Module.

INSPECTION:

STEP	ACTION	YES	NO
1	Was "Immobilizer Diag. Flow Table" performed?	Go to Step 2.	Go to "Immobilizer Diag. Flow Table".
2	1) Ignition switch OFF. 2) Disconnect connectors from Immobilizer Control Module. 3) Check for proper connection to Immobilizer Control Module at all terminals. Are they in good condition?	Substitute a known-good Immobilizer Control Module and recheck.	Repair or replace.

DTC13 NO TRANSPONDER CODE TRANSMITTED FROM IGNITION KEY
DTC14 COIL ANTENNA CIRCUIT MALFUNCTION

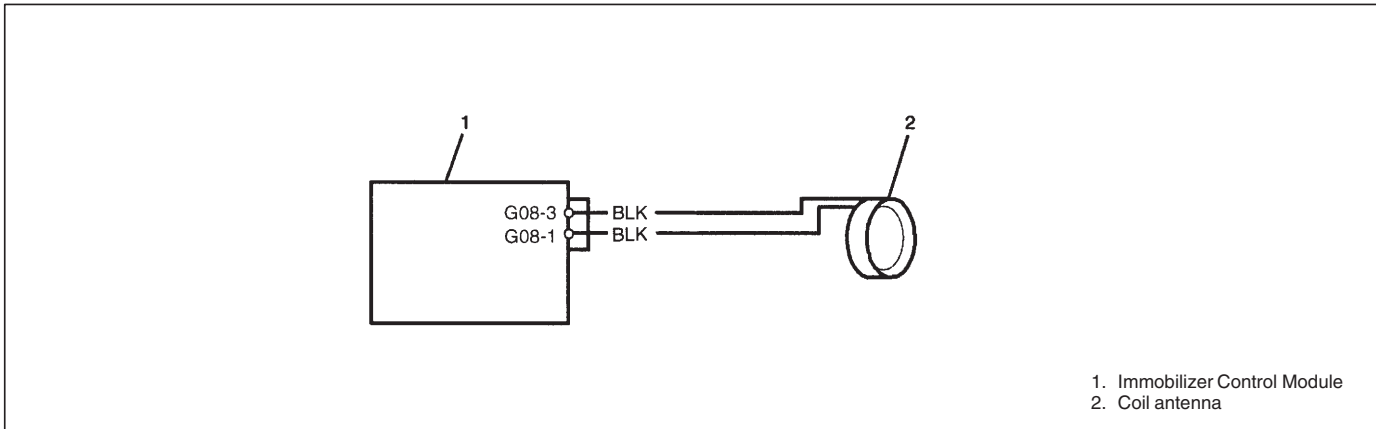

DESCRIPTION:

Immobilizer Control Module energizes the coil antenna when the ignition switch is ON and reads Transponder code from the ignition key. When Immobilizer Control Module cannot read Transponder code from the ignition key even when the coil antenna is energized, DTC 13 and 14 are set.

INSPECTION:

STEP	ACTION	YES	NO
1	Was "Immobilizer Diag. Flow Table" performed?	Go to Step 2.	Go to "Immobilizer Diag. Flow Table".
2	1) Disconnect coil antenna coupler with ignition switch turned OFF. 2) Is there continuity between coil antenna coupler terminals G08-1 and G08-3? (See Fig. 1)	Go to Step 3.	Coil antenna open.
3	Measure resistance between terminals of coil antenna coupler and body ground. (See Fig. 2) Is it ∞ (infinity) Ω ?	Go to Step 4.	Coil antenna shorted to ground.
4	Poor G08-1 or G08-3 connection. 1) If connections are OK, substitute a known-good coil antenna. 2) Is DTC 13 and/or 14 also indicated with ignition switch turned ON?	Substitute a known-good Immobilizer Control Module and recheck.	Faulty coil antenna.

Fig. 1 for Step 2

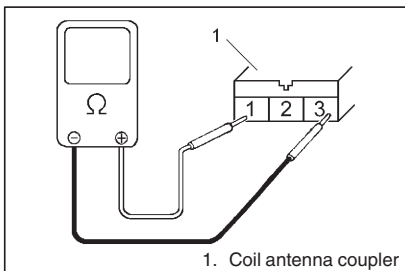
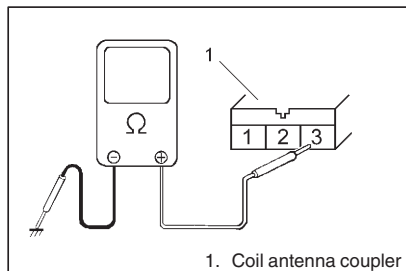
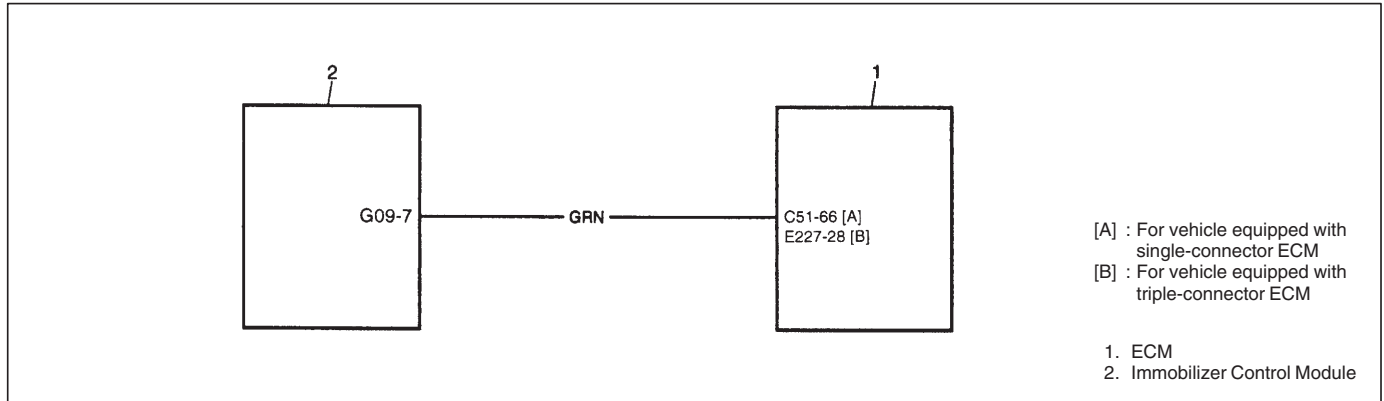

Fig. 2 for Step 3



DTC41 ECM NOT REGISTERED



DESCRIPTION:

Immobilizer Control Module checks whether immobilizer system is locked with ignition switch OFF. If the system is unlocked, DTC 41 is set.

INSPECTION:

STEP	ACTION	YES	NO
1	Was "Immobilizer Diag. Flow Table" performed?	Go to Step 2.	Go to "Immobilizer Diag. Flow Table".
2	1) Disconnect ECM coupler. 2) Disconnect coupler at immobilizer control module. 3) Is there continuity between G09-7 of immobilizer control module coupler and C51-66 in coupler of ECM equipped with single-connector or E227-28 in coupler of ECM equipped with triple-connector? See Fig. 1 and 2.	Go to Step 3.	● "GRN" wire open or, Poor G09-7 terminal connection
3	1) Check resistance between G09-7 of immobilizer control module coupler and body ground. See Fig.1 and 2. Is it infinity (∞)?	● Poor G09-7, C51-66 and E227-28 terminal connection If all above are OK, register ECU code in ECM according to "Procedure after ECM Replacement" section. And then go to Step 4.	"GRN" wire shorted to ground
4	1) Read DTC according to "Diagnostic Trouble Code Check" section. Does Suzuki scan tool indicate DTC 41 again?	Substitute a known-good ECM and recheck.	Go to "Immobilizer Diag. Flow Table".

Fig. 1 for Step 2 and 3

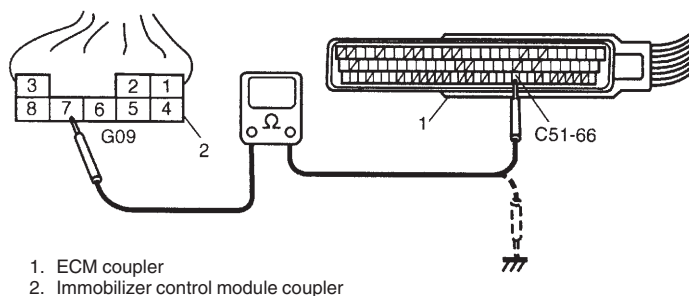
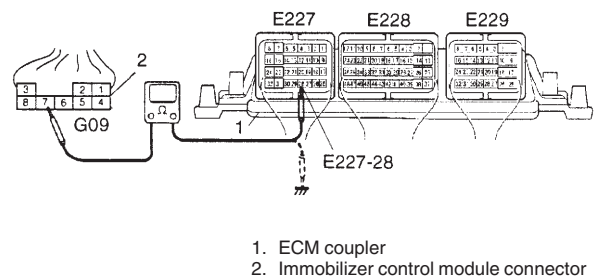
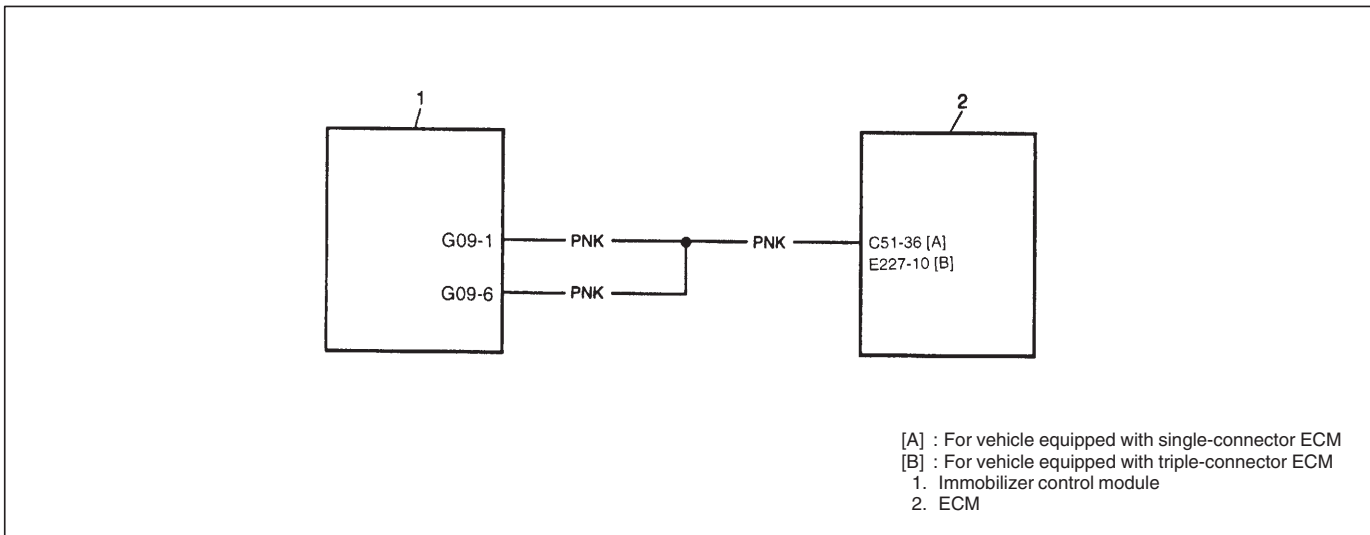

Fig. 2 for Step 2 and 3



DTC42 SERIAL DATA CIRCUIT MALFUNCTION (BETWEEN IMMOBILIZER CONTROL MODULE AND ECM)



DESCRIPTION

If ECU code is not transmitted from ECM, Immobilizer Control Module sets DTC42.

INSPECTION:

STEP	ACTION	YES	NO
1	Was "Immobilizer Diag. Flow Table" performed?	Go to Step 2.	Go to "Immobilizer Diag. Flow Table".
2	1) Disconnect coupler at immobilizer control module. 2) Check for proper connection to immobilizer control module at each terminal. If OK, check voltage between coupler terminal below and body ground with ignition switch ON. See Fig.1. ● G09-6 and body ground ● G09-1 and body ground Are they 10 – 14 V?	Substitute a known-good Immobilizer Control Module and recheck.	● "PNK" wire open shorted to ground. or ● Poor C51-36 or E227-10 terminal connection If all above are OK, substitute a known-good ECM and recheck.

Fig. 1 for step 2

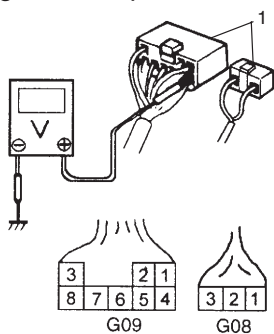

1. Immobilizer Control Module Coupler

DTC43 ECU CODE NOT MATCHED**DESCRIPTION:**

Immobilizer Control Module and ECM check if ECU codes registered in them respectively match. If the codes do not match, Immobilizer Control Module sets DTC 43.

INSPECTION:

STEP	ACTION	YES	NO
1	Was "Immobilizer Diag. Flow Table" performed?	Go to Step 2.	Go to "Immobilizer Diag. Flow Table".
2	1) Register ECU code in immobilizer control module according to "Procedure after Immobilizer Control Module Replacement" section. 2) Read DTC according to "Diagnostic Trouble Code Check" section. Does Suzuki scan tool indicate DTC 43 again?	Faulty ECM.	Go to "Immobilizer Diag. Flow Table".

INSPECTION OF IMMOBILIZER CONTROL MODULE AND ITS CIRCUIT

Immobilizer Control Module and its circuit can be checked at Immobilizer Control Module wiring coupler by measuring voltage and resistance. Described here is only inspection of Immobilizer Control Module.

CAUTION:

Immobilizer Control Module cannot be checked by itself. It is strictly prohibited to connect voltmeter or ohmmeter to Immobilizer Control Module with coupler disconnected from it.

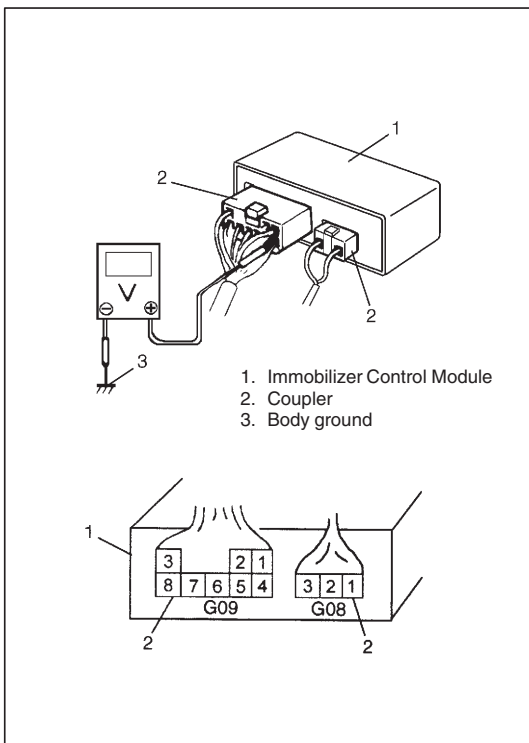

Voltage Check

- 1) Remove Immobilizer Control Module from body with ignition switch OFF referring to IMMOBILIZER CONTROL MODULE REMOVAL in this section.
- 2) Connect Immobilizer Control Module couplers to Immobilizer Control Module.
- 3) Check voltage at each terminal of couplers connected.

NOTE:

As each terminal voltage is affected by the battery voltage, confirm that it is 11 V or more when ignition switch is ON.

TERMINAL	CIRCUIT	NORMAL VOLTAGE	CONDITION
G08-1	Coil antenna +	0 V	Ignition switch ON
G08-2	–	–	–
G08-3	Coil antenna –	0 V	Ignition switch ON
G09-1	Serial data line between ECM and immobilizer control module	10 – 14 V	Ignition switch ON and OFF
G09-2	–	–	–
G09-3	Power supply	10 – 14 V	Ignition switch ON and OFF
G09-4	GND	–	–
G09-5	Serial data line between Suzuki scan tool and immobilizer control module	4 – 5 V	Ignition switch ON and OFF
G09-6	Serial data line between ECM and immobilizer control module	10 – 14 V	Ignition switch ON and OFF
G09-7	Power control of ECM	0 V	Ignition switch ON and OFF
G09-8	Ignition signal	0 V	Ignition switch OFF
		10 – 14 V	Ignition switch ON

NOTE:

When measuring voltage at G08-1 and G08-3 terminals with ignition switch turned ON, be sure to turn ignition switch ON before connecting positive probe of voltmeter to G08-1 or G08-3 terminal. If it is not turned ON first, DTC13 (Diagnostic Trouble Code 13) may be indicated.

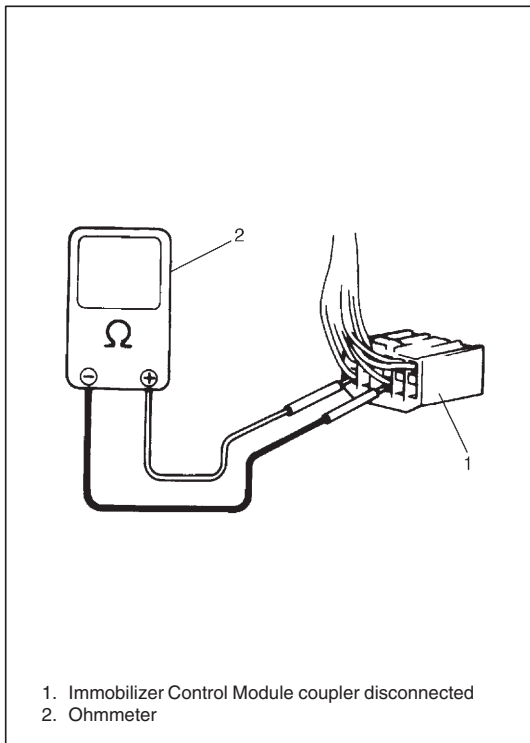

Resistance Check

- 1) Disconnect Immobilizer Control Module couplers from Immobilizer Control Module with ignition switch OFF.

CAUTION:
Do not touch terminals of Immobilizer Control Module itself or connect voltmeter or ohmmeter.

- 2) Check resistance between each terminal of couplers disconnected.

CAUTION:

- Be sure to connect ohmmeter probe from wire harness side of coupler.
- Be sure to turn OFF ignition switch for this check.
- Resistance in table below represents that when parts temperature is 20°C (68°F).

TERMINAL	CIRCUIT	NORMAL RESISTANCE	CONDITION
G08-1 – G08-3	Coil antenna	Continuity	–

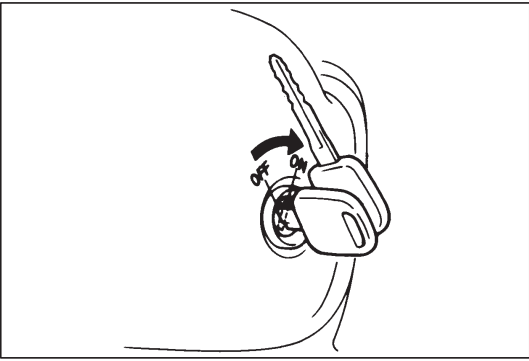

ON-VEHICLE SERVICE

PRECAUTIONS IN HANDLING IMMOBILIZER CONTROL SYSTEM

- Don't turn ON ignition switch with ignition key for immobilizer control system put together with another one or placed quite close to another one. Or the system may detect abnormal condition and prevent engine from starting.

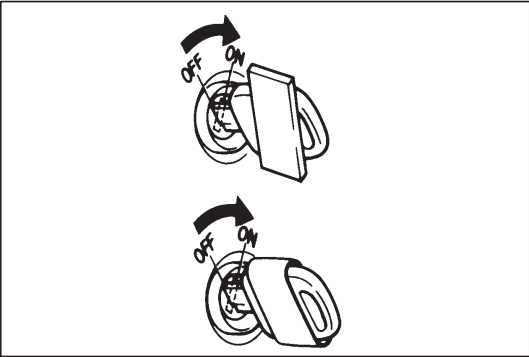

- Do not turn ON ignition switch by using ignition key with any type of metal wound around its grip or in contact with it. Or the system may detect abnormal condition and prevent engine from starting.

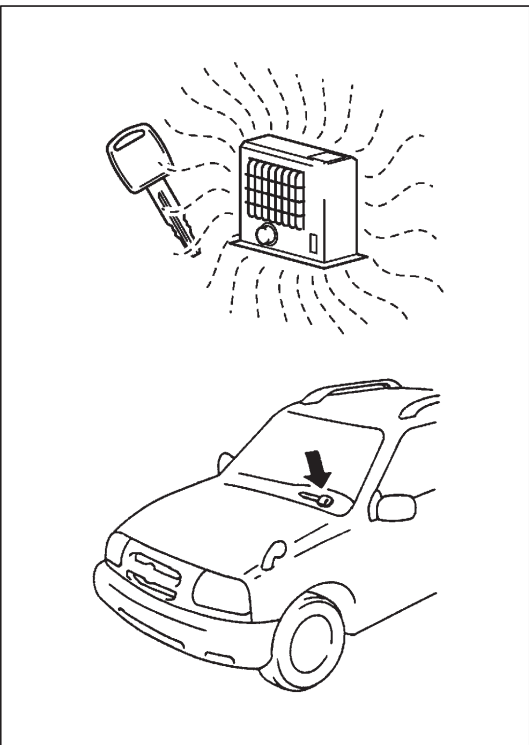

- Do not leave ignition key where high temperature is anticipated. High temperature will cause transponder in ignition key to be abnormal or damaged.

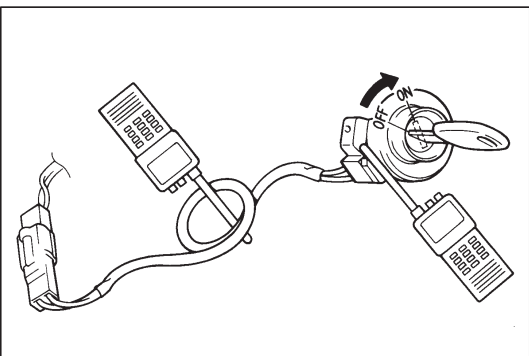

- Do not turn ON ignition switch with a radio antenna placed near coil antenna or its harness to Immobilizer Control Module. Or the system may detect abnormal condition and prevent engine from starting.

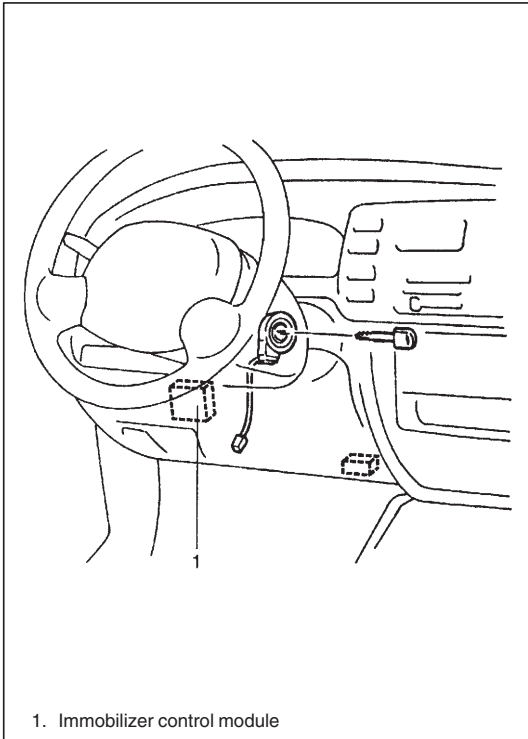

IMMOBILIZER CONTROL MODULE

Removal

- 1) Disconnect negative (–) cable at battery.
- 2) Remove steering column hole cover.
- 3) Disconnect couplers.
- 4) Remove immobilizer control module.

Installation

Reverse removal procedure for installation

NOTE:

After replacing Immobilizer Control Module, be sure to register Transponder code and ECU code in Immobilizer Control Module by performing procedure described in “Procedure after Immobilizer Control Module Replacement”.

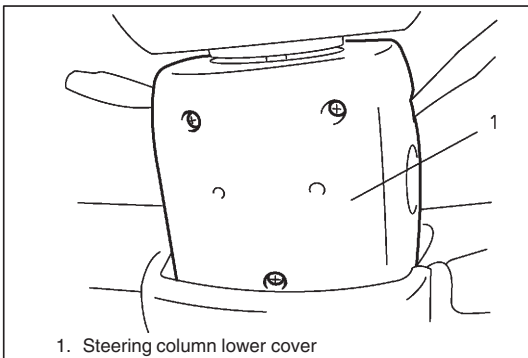

COIL ANTENNA

Removal

- 1) Disconnect negative (–) cable at battery.
- 2) Remove steering column upper and lower cover by removing 3 screws.
- 3) Remove steering column hole cover.

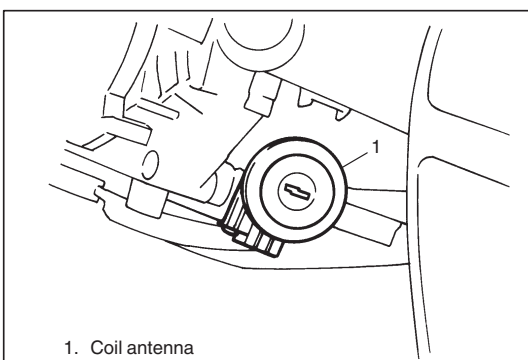

- 4) Remove coil antenna.

Installation

For installation, reverse removal procedure.

HOW TO REGISTER IGNITION KEY

Register the ignition key with a built-in transponder in Immobilizer Control Module by using the following procedure.

- 1) Prepare Suzuki scan tool.
- 2) With ignition switch OFF, connect Suzuki scan tool to data link connector (DLC) located on underside of instrument panel at driver's seat side.

Special Tool

(A): SUZUKI scan tool

NOTE:

For operation procedure of Suzuki scan tool, refer to Suzuki scan tool operator's manual.

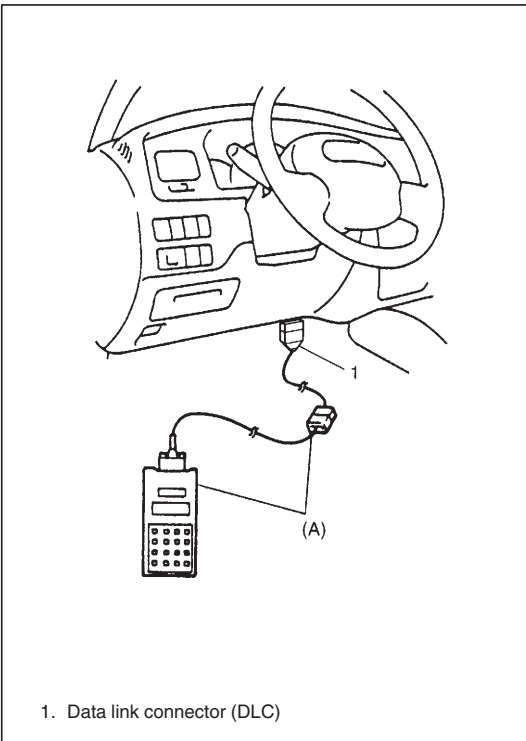

1. Data link connector (DLC)

- 3) Prepare ignition key with a built-in transponder. And then turn ignition switch ON by using it.
- 4) Number of Transponder codes for ignition key with a built-in transponder that can be registered in Immobilizer Control Module is limited to 4. If needed, clear all Transponder codes for ignition key with a built-in transponder that have been registered in Immobilizer Control Module by executing the "F2: CLR. TRANS COD (Clear transponder code)" command in the SELECT MODE menu by using Suzuki scan tool.

NOTE:

When "CLR. TRANS COD (Clear transponder code)" command is executed while no DTC is stored in the immobilizer control module, the immobilizer system remains unlocked. The immobilizer system changes into the locked state if the ignition switch is turned off for 10 seconds or longer and then turned on.

- 5) Using Suzuki scan tool, register Transponder code in Immobilizer Control Module by executing "ENT. TRANS COD (Enter transponder code)" command in SELECT MODE menu.
- 6) Make sure that no DTC is displayed on Suzuki scan tool after ignition switch is turned OFF for 10 seconds or more and then ON.

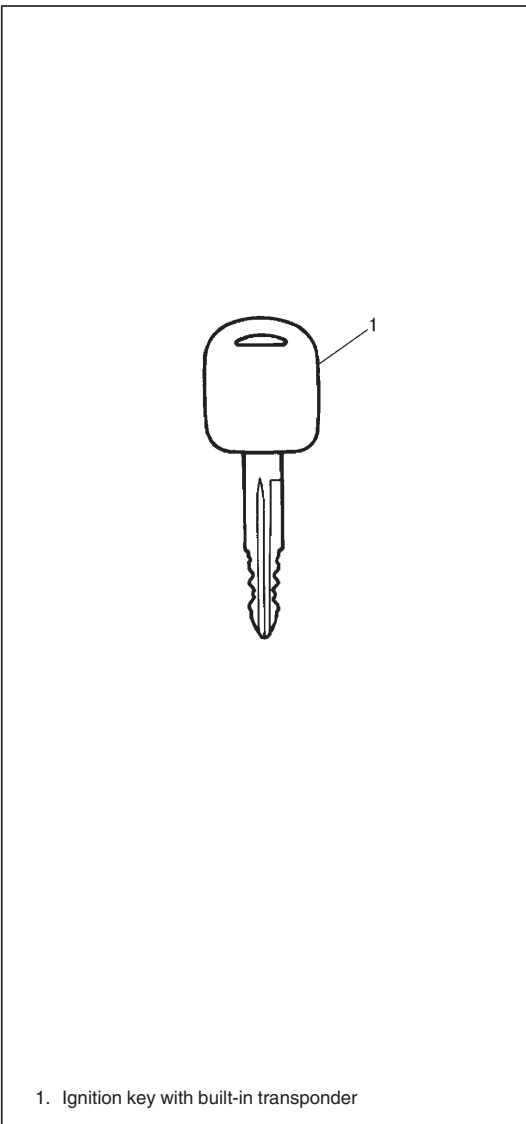

1. Ignition key with built-in transponder

- 7) If any other Transponder code for ignition key with a built-in transponder needs to be registered, repeat above Steps 3), 5) and 6).

NOTE:

- Up to 4 Transponder codes for ignition key with a built-in transponder can be registered.
- It is not possible to register the same Transponder code for ignition key with a built-in transponder as the one already registered in Immobilizer Control Module.

PROCEDURE AFTER IMMOBILIZER CONTROL MODULE REPLACEMENT

When Immobilizer Control Module was replaced, including when replaced because rechecking by using a known-good Immobilizer Control Module was necessary during trouble diagnosis, register Transponder code and ECU code in Immobilizer Control Module by performing following procedure.

- 1) Perform Steps 1) and 2) described in “How to register ignition key” section.
- 2) Prepare ignition key with a built-in transponder. And then turn ignition switch ON by using it.
- 3) Using Suzuki scan tool, clear all transponder codes registered in Immobilizer Control Module by executing “CLR. TRANS COD (Clear transponder code)” command in SELECT MODE menu.

NOTE:

When “CLR. TRANS COD (Clear transponder code)” command is executed while no DTC is stored in the immobilizer control module, the immobilizer system remains unlocked. The immobilizer system changes into the locked state if the ignition switch is turned off for 10 seconds or longer and then turned on.

- 4) Using Suzuki scan tool, register Transponder code in Immobilizer Control Module by executing “ENT. TRANS COD (Enter transponder code)” command in SELECT MODE menu.

- 5) Using Suzuki scan tool, register ECU code in Immobilizer Control Module by executing “IMMOBI CONT” command in RECORD ECU menu.

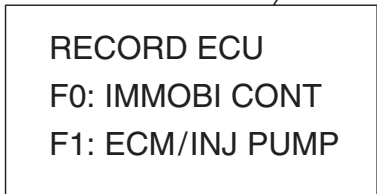

RECORD ECU
F0: IMMOBI CONT
F1: ECM/INJ PUMP

1. Suzuki scan tool screen

CAUTION:

While IMMOBI CONT command is being executed, Suzuki scan tool requires VIN to be entered. When entering VIN, make sure to follow the procedure described in Operator’s Manual supplied with the immobilizer cartridge. Incorrect VIN will cause the immobilizer system to be locked (engine unable to start).

- 6) Make sure that no DTC is displayed on Suzuki scan tool after ignition switch is turned OFF for 10 seconds or more and then ON.
- 7) If any other Transponder code for ignition key with a built-in transponder needs to be registered, repeat above Steps 2), 4) and 6).

NOTE:

- Up to 4 Transponder codes for ignition key with a built-in transponder can be registered.
- It is not possible to register the same Transponder code for ignition key with a built-in transponder as the one already registered in Immobilizer Control Module.

PROCEDURE AFTER ECM REPLACEMENT

CAUTION:

After replacing the ECM with a new one whose ECU code has not been registered, be sure to register it according to the following procedure. Without registration, the immobilizer system does not operate properly.

NOTE:

- ECU code can be registered to the ECM once only.
- If both immobilizer control module and ECM are replaced at the same time, execute “Procedure after Immobilizer Control Module replacement” first and then “Procedure after ECM replacement”.

When ECM was replaced, register ECU code in ECM by performing following procedure.

- 1) Perform Steps 1) and 2) described in “How to register ignition key” section. And then turn ignition switch ON.

RECORD ECU
 F0: IMMOBI CONT
 F1: ECM/INJ PUMP

2) Using Suzuki scan tool, register ECU code in ECM by executing “ECM/PCM” command in RECORD ECU menu.

NOTE:

- Turn on and off the ignition switch according to the instructions that appear on the screen of Suzuki scan tool.
- It takes 1 minute (max) until registration of ECU code to the ECM is completed.

3) Make sure that no DTC is displayed on Suzuki scan tool after ignition switch is turned OFF for 10 seconds or more and then ON.

SPECIAL TOOLS

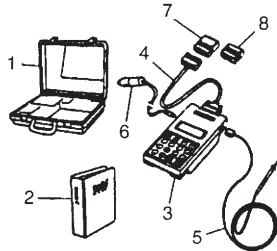
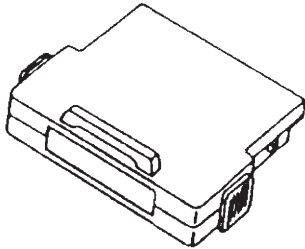
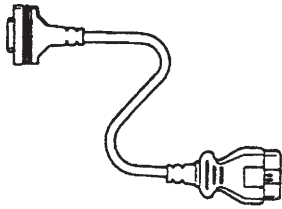
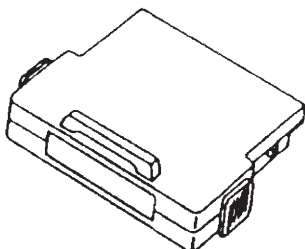
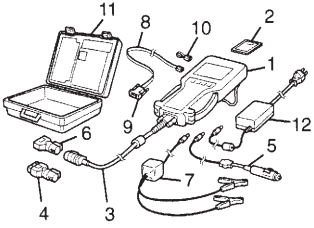
 <p>09931-76011 Tech 1A kit (SUZUKI scan tool) See NOTE “A” below.</p>	 <p>Immobilizer cartridge of version 1.4 or more for Tech 1A</p>	 <p>09931-76030 16/14 pin DLC cable</p>	 <p>Mass storage cartridge of version 1.7 or more for Tech 1A</p>
 <p>Tech 2 kit (SUZUKI scan tool) See NOTE “B” below.</p>			

NOTE:

- “A”: This kit includes the following items and substitutes for the Tech 2 kit.
 1. Storage case, 2. Operator’s manual, 3. Tech 1A, 4. DLC cable, 5. Test lead/probe, 6. Power source cable, 7. DLC cable adaptor, 8. Self-test adaptor
- “B”: This kit includes the following items and substitutes for the Tech 1 kit.
 1. Tech 2, 2. PCMCIA card, 3. DLC cable, 4. SAE16/19 adapter, 5. Cigarette cable, 6. DLC loopback adapter, 7. Battery power cable, 8. RS232 cable, 9. RS232 adaptor, 10. RS232 loopback connector, 11. Storage case, 12. Power supply

Prepared by
SUZUKI MOTOR CORPORATION

1st Ed. Feb., 2002

Printed in Japan

Printing:

600